



# FIRE ENGINEERING GUIDELINES

FIRST EDITION - MARCH 1996



# **FIRE ENGINEERING GUIDELINES**

Fire Code Reform Centre Limited



## **ENDORSEMENTS**

The following organisations have endorsed this document as describing an appropriate engineering methodology for design and assessment of fire safety in buildings by competent practitioners

- Australian Building Codes Board (ABCB)
- Australian Fire Authorities' Council (AFAC)
- Australian Institute of Building Surveyors (AIBS)
- The Institution of Engineers, Australia (IEAust)  
- through its Society of Fire Safety

## **APPLICATIONS**

The procedures and methodologies outlined are directly relevant in the following activities, although this is not an exhaustive list:

- to establish design equivalence with the specified fire provisions of the Building Code of Australia (BCA);
- to formulate design requirements for fire safety systems in buildings for which the specified BCA fire-safety provisions are inappropriate or cannot be applied;
- to develop suitable fire-safety requirements for refurbishment of existing buildings;
- to determine appropriate fire-safety provisions for heritage buildings or other properties of a similarly unique nature;
- to establish appropriate levels for property protection, continuity of operation and environmental safety in buildings.

## **IMPORTANT NOTE**

This Fire Engineering Guidelines document is not a design Code and does not detail all the engineering technology required for building fire-safety design. It outlines procedures and methodologies for undertaking building fire-safety designs and is intended primarily for use by suitably qualified and competent fire engineering practitioners, who are fully familiar with modelling the capricious nature of fire and of the behaviour of materials, structures and people when exposed to fire hazards. Fire engineering design activities require the application of professional knowledge, engineering judgments and appropriate understanding of the assumptions, limitations and uncertainties involved.

In addition to suitably qualified and competent fire engineering practitioners, the information contained in this document will also be of interest to other parties involved in building design, construction and refurbishment - and to those regulatory officials, fire service personnel and building surveyors who are involved in assessment and checking of fire safety designs submitted for approval.

The contents of this document have been assembled by eminent Australian fire engineers and scientists and have been derived from various sources which are believed to be correct and to be the best information available internationally as at March 1996. However, the information provided is of an advisory nature and is not claimed to be an exhaustive treatment of the subject matters. Neither the authors, Fire Code Reform Centre Limited, nor any of the organisations which have endorsed this document warrant or make any representation whatsoever that the information contained in this document, or the procedures and methodologies set out in it, or any advice derived therefrom, will be suitable for all fire engineered, building fire-safety designs.



## **FOREWORD**

For the past decade it has been apparent that skills have existed in Australia capable of developing engineered and scientifically based fire-safety requirements that will offer substantial improvement over the currently prescribed fire regulations. As design and operation of buildings have changed, the prescriptive nature of regulations has imposed limits on planning and construction which have added unnecessary costs. Despite this, Australia has achieved a good record in building fire-safety and all parties agree this must be maintained.

Fire safety involves control of risk to life and often to property. Without appropriate risk-assessment methodology, it is impossible to quantify risk or compare alternative design solutions. The procedures involved are complex, require extensive research, data and use of computers. Risk assessment methodology has been successfully applied in regulations for catastrophic events such as earthquakes and extreme winds, and fire risk can be similarly predicted.

The strategy behind the foundation and operation of Fire Code Reform Centre Limited (FCRC) has been to bring together all the major participants in the fire industry in Australia, through a cooperative effort, to undertake and manage the research appropriate to fire codes and regulations. Government, industry and research participants have formulated its Research Program and are assisting by contributing funds and directing its contracts.

FCRC is a successful, possibly unique, partnership. One of the lasting benefits to Australia will be the presence of researchers in universities and research establishments who are at the forefront of fire science and engineering and who will be able to support Australian consultants and contractors in the design of innovative buildings at home and overseas.

Establishment of FCRC was made possible by the pledge of funding from the Member Governments comprising the Australian Building Codes Board (ABCB). This and the continuing support of ABCB, through its Chairman Mr Jim Service AM and Executive Officers, is much appreciated. To date, matching funding and support for FCRC activities has been raised from other sources. All these contributions are very gratefully acknowledged.

For their foresight in supporting FCRC through its fragile formative phase, special mention is deserved by members of the former Australian Uniform Building Regulations Coordinating Council, particularly Mr Robert Hogg its Executive Director; by FCRC's first major sponsor, the National Association of Forest Industries Limited (Mr Robert Appleton, Fire Research Director); and by the several research and industry personnel involved in development of FCRC's Business and Research Plans. Acknowledgement is also made of the energy and dedication of Mr Claude Eaton, throughout the periods before and after FCRC's incorporation.

Dr John Nutt AM  
Chairman, Fire Code Reform Centre Limited.



## **FIRE CODE REFORM CENTRE LIMITED**

Fire Code Reform Centre Limited (FCRC) is an independent, non-profit Company and an Approved Research Institute under Australian taxation law. Its mission is to advance the technological basis for cost-effective and fully engineered building fire-safety requirements by administering and directing a defined Research Program to facilitate regulatory reform being undertaken by the Australian Building Codes Board (ABCB).

FCRC seeks financial support, which is tax deductible, from government, industry, research organisations and individuals interested in building fire-safety. ABCB has agreed, subject to satisfactory progress and the evident participation of others, to contribute \$500,000 per annum for each of 5 years.

FCRC particularly acknowledges the generous financial support it has received from its financial sponsors and from the organisations and scientists involved in its research activities under contracts at concessional rates. Additionally, individuals participate voluntarily on FCRC's Board of Directors, Industry Advisory Group and Research Supervisory Committee and these contributions are gratefully acknowledged.

## **FINANCIAL SPONSORS**

The following lists the major sponsors to FCRC's activities, as at 1st February 1996. Many other organisations and individuals have also contributed to the funding of FCRC's defined research projects. All this support is sincerely acknowledged.

AMP Investments Australia Limited  
ANZ Banking Group Limited  
Australian Building Codes Board  
BHP Steel  
Building Control Commission.Victoria  
Cement & Concrete Research Association  
Civil and Civic Pty Ltd  
Forest & Wood Products R & D Corporation  
James Hardie Building Services Limited  
Leighton Contractors Pty Ltd  
National Association of Forest Industries Limited  
NSW Department of Public Works  
Standards Association of Australia  
St Martins Properties (Australia) Pty Ltd  
Steel Reinforcement Institute of Australia  
Westfield Design & Construction Pty Ltd



Members of FCRC's BOARD OF DIRECTORS (As at 1st February 1996) are:

Dr John Nutt AM (Chair)	Ove Arup and Partners
Mr Garry Payne (Dep. Chair)	Member, Australian Building Codes Board
Mrs Kathryn Adams	Forest & Wood Products R & D Corporation
Mr Robert G. Appleton	National Association of Forest Industries Limited
Mr John R. Coghlan AM	Member, Australian Building Codes Board
Mr Leonard R. Foster	Australian Fire Authorities' Council
Mr Stewart Horwood	Standards Association of Australia
Mr Ian Riley	Cement & Concrete Research Association

Members of FCRC's INDUSTRY ADVISORY GROUP (as at 1st February 1996) are:

Dr John Nutt (Chair)	Fire Code Reform Centre Limited
Mrs Kathryn Adams	Forest & Wood Products R & D Corporation
Mr Peter Barda	Facet Management Pty Ltd
Mr John Carson	National Association of Forest Industries Limited
Ms Carmel Coate	Fire Protection Industry Association of Australia
Mr Geoff Crittenden	The Association of Consulting Engineers, Australia
Mr Jim Dance	Australian Fire Authorities' Council, and Commonwealth Fire Board
Mr Lyall Dix	Australian Building Codes Board
Mr Tony Fisher	Royal Australian Institute of Architects
Mr Ian Gordon	Australian Institute of Building Surveyors
Mr Alan Griffen	National Public Works Council
Mr Robert Hogg	Department of Industry, Science and Technology
Mr Ronald Keith	Australian Fire Protection Association Limited
Mr Peter Verwer	Building Owners' and Managers' Asscn of Aust. Ltd

Members of FCRC's RESEARCH SUPERVISORY COMMITTEE (as at 1st Feb. 1996) are:

Mr Robert Appleton (Chair)	National Association of Forest Industries Limited
Mr Ernest Calvert (Deputy)	Australian Building Codes Board
Mrs Kathryn Adams	Forest & Wood Products R & D Corporation
Mr Richard Dinham	Royal Australian Institute of Architects
Mr Stephen Durnford	Australian Building Codes Board
Mr Barry Eadie	Australian Fire Authorities' Council
Mr David Gardner,	State Forests of New South Wales
Dr Tony Green	WorkCover Authority of New South Wales
Mr Raymond Lacey	Lincolne Scott Australia Pty Ltd
Mr Barry Lee	Australian Fire Protection Association Ltd
Mr Raymond Loveridge	Ray Loveridge and Associates Pty Ltd
Mr Bob Potter	Cement & Concrete Association of Australia
Emeritus Prof. Len Stevens	Dept. of Civil & Environm'l Engg., Univ. of Melbourne
Mr Colin Wood	Australian Institute of Building Surveyors

## **FCRC's Research Program**

FCRC's Research Program has two primary aims, viz:-

- to introduce flexibility and modern technology into significant aspects of the "deemed to satisfy" prescriptions of the Building Code of Australia (BCA), and
- to develop a fully engineered, risk-assessment approach to building fire-safety to facilitate adoption (when desired) of alternative design arrangements from those prescribed within the BCA.

As at 1st February 1996, seven projects are included within FCRC's Research Program. These follow the closely inter-related paths indicated above and are being undertaken concurrently.

Project 1 - "Re-structure BCA Fire Provisions"; Project 2 - "Fire Performance of Materials" and Project 3 - "Fire Resistance and Non-combustibility" relate to BCA improvement. Outputs from these will be provided progressively to the Australian Building Codes Board (ABCB) for incorporation into future building regulations.

Project 4 - "Fire Safety Design Solutions"; Project 5A - "Fire Engineering Guidelines" and Project 5B - "Fire Safety Design Code" relate to the alternative design approach. Outputs from these, following appropriate endorsement from regulatory authorities, will be made directly available to industry.

The recently added Project 6 - "Fire Safety Systems for Sprinklered, Low-rise Shopping Centres" will draw from, and contribute to, other projects in both these streams.

This First Edition of "Fire Engineering Guidelines" is the formal output from FCRC's Project 5A. The future will bring progressive expansion and improvement of the technologies referred to herein. These will arise from continuing international advancement of fire science and from the experience of competent practitioners, in Australia and overseas, who are involved in the application of this relatively new engineering discipline. Accordingly these Guidelines are expected to be revised from time to time and contributions to assist in this regard will be welcomed.

### **Comments are genuinely sought**

Comments of any type, on the contents, format or other aspects of this document are earnestly requested from any person or organisation having interest in building fire-safety. Such comments should be directed to:

Fire Code Reform Centre Limited,  
4th Floor, 50 King Street,  
Sydney NSW 2000,  
Australia.

Tel: +61 (2) 262-4358 Fax: +61 (2) 262-4255



# TABLE OF CONTENTS

		<b>Page</b>
	<b>PREFACE</b>	
<b>1.</b>	<b>SCOPE</b>	<b>1.1</b>
<b>2.</b>	<b>DEFINITIONS</b>	
	2.1 Definitions	2.1
<b>3.</b>	<b>GENERAL - FRAMEWORK OVERVIEW</b>	
	3.1 Introduction	3.1
	3.2 General	3.2
	3.3 Design Process	3.2
	3.4 Conceptual Design	3.4
	3.5 Fire Engineering Design Brief (FEDB)	3.5
	3.6 Quantified Analysis	3.5
	3.6.1 General	3.5
	3.6.2 Level 1 - Component and Sub-system Equivalence Evaluation (SEE)	3.8
	3.6.3 Level 2 - System Performance Evaluation (SPE)	3.8
	3.6.4 Level 3 - System Risk Evaluation (SRE)	3.9
	3.7 Fire Scenario Analysis	3.10
	3.8 Evaluation	3.13
	3.9 Reporting and presentation	3.14
	3.10 Design Approval	3.14
	3.11 Implementation and Operation	3.14
	3.12 Change of Use	3.15
<b>4.</b>	<b>FIRE ENGINEERING DESIGN BRIEF</b>	
	4.1 General	4.1
	4.2 Design Objectives	4.2
	4.2.1 General	4.2

	<b>Page</b>	
4.2.2	BCA Objectives	4.3
4.2.3	Loss Control Objectives	4.3
4.2.4	Fire Brigade Objectives	4.4
4.2.5	Environmental/Community Protection	4.4
4.3	Acceptance Criteria	4.4
4.3.1	General	4.4
4.3.2	Comparison of Performance	4.5
4.3.3	Level 1 Acceptance Criteria	4.5
4.3.4	Level 2 Acceptance Criteria	4.6
4.3.5	Level 3 Evaluation Criteria	4.9
4.4	Hazard Identification	4.10
4.5	Fire scenarios	4.10
4.6	Trial Concept Design	4.11
4.7	Methods of evaluation	4.12
4.8	Design Documentation and Reporting	4.13
4.9	Detailed Design and Documentation	4.14

## **5. DESIGN GUIDANCE**

5.1	Introduction	5.1
5.2	Planning and Design Considerations	5.2
5.2.1	The Building Project Process	5.2
5.2.2	Planning of Occupants	5.3
5.2.3	Planning and Fire Scenario	5.4
5.2.4	Planning - Detection and Suppression	5.4
5.3	Fire Initiation and Development Design	5.5
	Considerations	
5.4	Smoke management - design considerations.	5.6
5.5	Fire Management	5.7
5.5.1	General	5.7
5.5.2	Managing Flame Spread Within Combustibles	5.7
5.5.3	Managing Fire Spread to Adjacent Combustibles Within Fire Enclosure	5.8
5.5.4	Managing Fire Spread to Adjoining Enclosures	5.8
5.5.5	Managing Vertical Fire Spread	5.10

		<b>Page</b>
	5.5.6 Managing External Spread to Adjacent Buildings	5.10
5.6	Detection and Suppression	5.11
	5.6.1 Humans as Detectors	5.11
	5.6.2 Smoke Detectors	5.11
	5.6.3 Heat Detectors	5.12
	5.6.4 Flame Detectors	5.12
	5.6.5 Portable Extinguishers	5.12
	5.6.6 Automatic Sprinklers	5.13
	5.6.7 Gaseous Suppression Systems	5.13
5.7	Occupant Avoidance	5.14
	5.7.1 General	5.14
	5.7.2 Design Strategies	5.14
	5.7.3 Incorporating Occupant Behaviour and Characteristics into Design	5.14
	5.7.4 Concept Plan	5.16
5.8	Fire Brigade	5.17
	5.8.1 General	5.17

## **6. METHODS OF EVALUATION**

6.1	Fire Safety System	6.1
	6.1.1 Fire Safety Sub-systems	6.2
6.2	Approaches to Evaluation	6.2
6.3	Criteria for Evaluation	6.3
6.4	Different Levels of Evaluation	6.3
	6.4.1 General	6.3
	6.4.2 Sub-system Equivalence Evaluation / SEE(Level 1)	6.3
	6.4.3 System Performance Evaluation / SPE(Level 2)	6.3
	6.4.4 System Risk Evaluation / SRE (Level 3)	6.5
6.5	Fire Scenarios	6.6
	6.5.1 Fire scenarios - the basis for analysis and design evaluation	6.6
	6.5.2 Development of fire scenarios	6.6
	6.5.3 Quantify fire scenario occurrence	6.9
6.6	Principles for Evaluation	6.9

		<b>Page</b>	
	6.6.1	General	6.9
	6.6.2	Fire engineering models	6.10
	6.6.3	Selection of parameters	6.10
	6.6.4	Treatment of Uncertainty	6.10
	6.6.5	Data requirements	6.11
	6.6.6	Sensitivity analysis	6.11
6.7	Sub-system Equivalence Evaluation (SEE): Level 1 Comparative Performance of a Component/ Sub-system: Single/Multiple Fire Scenarios		6.12
	6.7.1	Scope	6.12
	6.7.2	Studies	6.12
	6.7.3	Evaluation criteria	6.12
	6.7.4	Procedure	6.12
6.8	System Performance Evaluation (SPE): Level 2 Single/Multiple Fire Scenario(s) not Combined		6.15
	6.8.1	Scope	6.15
	6.8.2	Studies	6.15
	6.8.3	Evaluation criteria	6.15
	6.8.4	Procedure	6.16
6.9	System Risk Evaluation (SRE): Level 3 Multiple Fire Scenarios Combined Using a Probabilistic Methodology		6.19
	6.9.1	Scope	6.19
	6.9.2	Studies	6.20
	6.9.3	Evaluation criteria	6.21
	6.9.4	Procedure	6.22
	6.9.5	Data required	6.28
	6.9.6	Other factors	6.29
6.10	Final Reporting		6.30

**7. CHARACTERISATION OF BUILDING, CONTENTS, PEOPLE AND ENVIRONMENT**

7.1	General	7.1
7.2	Characterisation of building and fire safety systems	7.2
	7.2.1 Building Characterisation	7.2

		<b>Page</b>
	7.2.2	Characterisation of fire safety systems 7.2
7.3		Characterisation of contents 7.3
	7.3.1	General 7.3
	7.3.2	Fire load 7.3
	7.3.3	Fire starts 7.6
	7.3.4	Choice of fire scenario 7.8
	7.3.5	Frequency of Fire Starts 7.10
7.4		Environmental effects 7.11
	7.4.1	General 7.11
	7.4.2	Effect of wind 7.11
	7.4.3	Wind direction 7.11
	7.4.4	External temperature 7.11
	7.4.5	Internal temperature 7.11
	7.4.6	Effect of snow 7.12
	7.4.7	Humidity 7.12
	7.4.8	Internal air movements 7.12
7.5		Occupant Characterisation 7.12
	7.5.1	Occupant Characterisation Generally 7.12
	7.5.2	Occupant capability in response 7.13
	7.5.3	Occupant coping capability 7.14
	7.5.4	Occupant evacuation/avoidance capability 7.14
7.6		Occupant Profile 7.15

**8. FIRE INITIATION AND DEVELOPMENT  
(SUB-SYSTEM 1 / SS1)**

8.1	General	8.1
8.2	Overview	8.1
	8.2.1	General 8.1
	8.2.2	Fire initiation and Development 8.2
	8.2.3	Ignition 8.3
	8.2.4	Pre-flashover 8.3
	8.2.5	Flashover 8.7
	8.2.6	Fully developed fire 8.8
	8.2.7	Decay 8.10
	8.2.8	Interventions 8.11
8.3	Use of sub-system	8.12
8.4	Inputs	8.12
	8.4.1	Fire Scenario 8.12



		<b>Page</b>
	8.4.2	Occupancy characteristics 8.13
	8.4.3	Enclosure geometry 8.14
	8.4.4	Activation of suppression 8.14
	8.4.5	Fire fighting activity 8.14
	8.4.6	Occupant Suppression 8.14
	8.4.7	Hot Layer temperature 8.14
	8.4.8	Creation of new openings 8.14
8.5	Outputs	8.14
	8.5.1	Instantaneous heat release rate 8.14
	8.5.2	Toxic species yield 8.14
	8.5.3	Smoke yield 8.15
	8.5.4	Flashover time 8.15
	8.5.5	Flame Height 8.15
8.6	Analysis	8.15
	8.6.1	Ignition 8.15
	8.6.2	Pre-flashover 8.17
	8.6.3	Flashover 8.24
	8.6.4	Fully Developed Fires 8.25
	8.6.5	Decay phase 8.27
	8.6.6	Interventions 8.27
	8.6.7	Flame Height 8.28

**9. SMOKE DEVELOPMENT AND MANAGEMENT  
(SUB SYSTEM 2/ SS2)**

9.1	General	9.1
9.2	Overview	9.1
	9.2.1	General 9.1
	9.2.2	Factors Affecting Smoke Development 9.2
	9.2.3	Smoke Movement in the Enclosure of Fire Origin 9.2
	9.2.4	Smoke Spread Beyond the Enclosure of Fire Origin 9.3
	9.2.5	Smoke Management 9.3
	9.2.6	Smoke Characteristics 9.4
	9.2.7	Measurement of Smoke 9.4
	9.2.8	Interactions 9.5

		<b>Page</b>
9.3	Use of Sub-system	9.6
	9.3.1 General	9.6
	9.3.2 Locations of interest	9.6
9.4	Inputs	9.6
	9.4.1 Geometry of enclosure	9.6
	9.4.2 Building characteristics	9.8
	9.4.3 Rate of heat release profile	9.8
	9.4.4 Toxic species yield	9.8
	9.4.5 Smoke yield	9.8
	9.4.6 Time of detector activation	9.8
	9.4.7 Environmental effects	9.8
9.5	Outputs	9.8
	9.5.1 Smoke temperature	9.8
	9.5.2 Smoke optical density	9.9
	9.5.3 Toxic species concentration	9.9
	9.5.4 Depth of hot layer	9.9
9.6	Analysis	9.9
	9.6.1 General	9.9
	9.6.2 Smoke Production in Enclosure of Fire Origin	9.10
	9.6.3 Smoke Spread to Other Enclosures	9.14
	9.6.4 Smoke Management Techniques	9.16
<b>10.</b>	<b>FIRE SPREAD AND MANAGEMENT (SUB-SYSTEM 3 / SS3)</b>	
10.1	Scope	10.1
10.2	Fire Spread Mechanisms	10.1
	10.2.1 General	10.1
	10.2.2 Means of fire spread	10.2
	10.2.3 Routes of fire spread	10.2
	10.2.4 Factors influencing fire spread	10.2
10.3	Use of Subsystem	10.3
	10.3.1 General	10.3
	10.3.2 Spread Routes	10.3
	10.3.3 Openings	10.3
	10.3.4 Barriers	10.3
	10.3.5 Structural adequacy	10.4

		<b>Page</b>	
	10.3.6	Application assumptions	10.4
10.4	Inputs		10.4
10.5	Outputs		10.6
10.6	Analysis		10.6
	10.6.1	General	10.6
	10.6.2	Procedures	10.6
	10.6.3	Heat transfer principles	10.6
	10.6.4	Fire severity	10.9
	10.6.5	Fire spread	10.12

**11. FIRE DETECTION AND SUPPRESSION  
(SUB-SYSTEM 4/SS4)**

11.1	General		11.1
11.2	Overview		11.1
	11.2.1	General	11.1
	11.2.2	Fire Detectors	11.2
	11.2.3	Automatic Suppression	11.4
11.3	Use of Sub-system		11.5
	11.3.1	General	11.5
	11.3.2	Fire Detection	11.6
	11.3.3	Automatic Suppression	11.6
11.4	Inputs		11.6
	11.4.1	General	11.6
	11.4.2	Fire Detection	11.6
	11.4.3	Automatic Suppression	11.9
11.5	Outputs		11.10
	11.5.1	General	11.10
	11.5.2	Fire Detection	11.10
	11.5.3	Automatic Suppression	11.10
11.6	Analysis		11.11
	11.6.1	General	11.11
	11.6.2	Fire Detection	11.11
	11.6.3	Automatic Suppression	11.19
	11.6.4	Manual Suppression	11.23

		<b>Page</b>
<b>12.</b>	<b>OCCUPANT AVOIDANCE (SUB-SYSTEM 5 / SS5)</b>	
12.1	General	12.1
12.2	Overview	12.1
	12.2.1 Philosophy / overall framework and submodel	12.2
	12.2.2 Design	12.4
12.3	Use of Sub-system	12.6
	12.3.1 General	12.6
12.4	Input	12.6
	12.4.1 Occupant Characteristics	12.6
	12.4.2 Building Characteristics	12.7
12.5	Output	12.7
	12.5.1 Occupant Avoidance Time	12.7
12.6	Analysis	12.7
	12.6.1 Preliminary Procedures	12.7
	12.6.2 Occupant Response	12.9
	12.6.3 Occupant Coping	12.14
	12.6.4 Occupant Evacuation/Avoidance	12.16
	12.6.5 Use of TR in System Performance Evaluation	12.19
<b>13.</b>	<b>FIRE BRIGADE COMMUNICATION AND RESPONSE (SUB-SYSTEM 6/SS6)</b>	
13.1	General	13.1
13.2	Overview	13.2
	13.2.1 Key Events & Times	13.2
13.3.	Use of Sub-system	13.4
	13.3.1 General	13.4
13.4	Inputs	13.4
	13.4.1 Notification time ( $t_n$ )	13.4
	13.4.2 Building location and access	13.4
	13.4.3 Building size, layout	13.4
	13.4.4 Evacuation time	13.4

		<b>Page</b>	
	13.4.5	Building occupancy, type, population and time of day	13.4
	13.4.6	Hydrant layout	13.5
	13.4.7	Heat release rate ( $HRR_{f0}$ )	13.5
13.5		Outputs	13.5
	13.5.1	General	13.5
	13.5.2	Dispatch Time	13.5
	13.5.3	Arrival Time	13.5
	13.5.4	Time to Complete Investigations	13.5
	13.5.5	Time to Complete Life Safety/ Search Rescue	13.5
	13.5.6	Time for Fire Attack	13.5
	13.5.7	Time for Fire Control	13.5
	13.5.8	Time to Fire Extinguishment	13.6
	13.5.9	Modified Heat Release Rate	13.6
13.6		Analysis	13.6
	13.6.1	General	13.6
	13.6.2	Arrival time ( $t_a$ )	13.6
	13.6.3	Time to complete investigations ( $t_i$ )	13.6
	13.6.4	Time to complete life safety search/ rescue ( $t_r$ )	13.7
	13.6.5	Time for fire attack ( $t_a$ )	13.7
	13.6.6	Time for fire control ( $t_c$ )	13.7
	13.6.7	Time for fire extinguished ( $t_e$ )	13.8
	13.6.8	Modification of Heat Release Rate	13.8
	13.6.9	Probability Prediction	13.8

## **APPENDICES**

APPENDIX 3A	DATA/INFORMATION INTERCHANGE BETWEEN SUB-SYSTEMS
APPENDIX 6A	QUANTIFICATION OF UNCERTAINTIES: AN OUTLINE
APPENDIX 6B	RISK ASSESSMENT
APPENDIX 7A	FIRE LOAD ENERGY DENSITIES
APPENDIX 7B	STATISTICAL DATA FROM THE AUSTRALIAN INCIDENT STATISTICS
APPENDIX 7C	TYPE OF MATERIAL IGNITED FIRST (1989-1993) SHOPPING CENTRES
APPENDIX 7D	GLOSSARY OF TERMS USED IN OCCUPANT CAPABILITIES TABLE

APPENDIX 9A	ASSESSMENT AND VERIFICATION OF COMPUTER MODELS
APPENDIX 9B	FIELD MODELS FOR FIRE SAFETY ENGINEERING
APPENDIX 10A	CALCULATING RADIANT HEAT FLUX ON REMOTE COMBUSTIBLE MATERIALS
APPENDIX 12A	DETAILED EGRESS DESIGN INFORMATION

## **INDEX**



## **PREFACE**

This 'Fire Engineering Guidelines' document for design and evaluation of fire safety in buildings has been prepared by a group of Australian fire research and engineering organisations for Fire Code Reform Centre Limited (FCRC).

This publication represents a further stage in the development in Australia over recent years of a performance-based approach to building fire-safety design and of fire engineering as a discipline in its own right. This commenced in 1989 when The Warren Centre for Advanced Engineering at the University of Sydney coordinated a study group under its "Fire Safety and Engineering Project".

On completion, one of the Project's principal recommendations was that design for fire safety should be an engineering responsibility, rather than a matter for prescriptive regulatory control. Another was that risk assessment models should be developed and validated for use in identifying cost-effective, fire safety system designs.

The Building Regulations Review Taskforce (established in May 1989 by the Federal Government to review Australian building regulations and standards) commissioned principal participants from The Warren Centre Project to codify the concepts of an alternative approach to building fire safety and by May 1991 a Draft National Building Fire Safety Systems Code (NBFSSC) had been developed.

Both The Warren Centre study and the NBFSSC project recommended further research, verification and development be undertaken to enable industry to benefit progressively from the performance-based approach and user-friendly application of a Fire Safety Design Code for buildings. This remains the principal mission of Fire Code Reform Centre Limited.

The draft NBFSSC was the world's first performance-based engineering code for the design of fire safety systems in buildings. It was based on a risk assessment methodology and introduced the concepts of fire engineering sub-systems and time-line analysis as the bases for performance evaluation. Subsequently, both the draft British Standard Code of Practice for "Application of Fire Safety Engineering Principles to Fire Safety in Buildings" and the ISO Working Groups related to building fire safety design have adopted and have further developed the major concepts and principles of the NBFSSC.

This version of "Fire Engineering Guidelines" builds on these earlier developments, and has been based on a number of key documents, including:

- Fire Safety and Engineering, Project Report and Technical Papers, The Warren Centre, The University of Sydney, (December, 1989)
- National Building Fire Safety Systems Code (draft), BRRTF, Australia (1991)
- British Standard Code of Practice for the Application of Fire Safety Engineering Principles to Fire Safety in Buildings, UK (1994)
- Fire Engineering Design Guide, University of Canterbury, New Zealand, (1994)



- Latest documents within ISO/TC92/SC4 on performance based fire engineering design.

In addition, significant new work has been added by the members of FCRC's Project 5A team responsible for preparation of this document. The organisations and members principally involved were:-

- Scientific Services Laboratory - Mr Peter Johnson  
(Principal Research Consultant and Project Leader)
- Victoria University of Technology - Prof. Vaughan Beck
- BHP Research Laboratories,  
Melbourne - Dr. Ian Thomas and Mr Leong Poon
- CSIRO Division of Building,  
Construction & Engg, Sydney - Mr Stephen Grubits &  
Mr Carlos Quaglia
- University of Technology, Sydney - Assoc. Prof. Hamish MacLennan

The team is indebted to Mr Mahmut Horasan from Victoria University of Technology for his work in collating, formatting and producing document drafts, as well as for his assistance on human behaviour and egress.

Progressive expansion and improvements to this document are expected as a result of:-

- continuing developments in the fields of fire science and engineering,
- further work and results from other projects in the FCRC Research Program,
- review and comments, which are invited from all sectors of the Australian and international fire protection community,
- usage by fire engineering consultants and approving authorities.

The writers are grateful to members of ISO/TC92/SC4 Working Groups; to members of the Building Codes Committee of the Australian Building Codes Board (ABCB); to members of the Fire Safety Officers' Consultative Committee of the Australian Fire Authorities' Council (AFAC); to members of the Research Supervisory Committee of Fire Code Reform Centre Limited (FCRC); and to a number of other selected organisations and individuals for their contributions and comment on the pre-publication draft of these guidelines.

The FCRC is committed to the further development of these guidelines, particularly as the ABCB develops the Performance BCA to which the guidelines will be strongly linked. As part of this commitment, further review and comment from any party within the fire safety community is invited.

Please submit comments to:-

Claude Eaton  
Business Manager  
Fire Code Reform Centre Ltd  
4th Floor, Rockliffs Chambers  
50 King St. Sydney, NSW 2000

Tel: +61 (2) 262-4358

Fax: +61 (2) 262-4255

### CHAPTER 1

### SCOPE

#### 1. SCOPE

This Fire Engineering Guidelines document identifies a methodology for design and assessment of fire safety in buildings. It identifies an engineering approach to building fire safety and gives guidance on the application of scientific and engineering principles to the protection of people and property from unwanted fire. Additionally it outlines a structured approach to assessment of total building fire safety system effectiveness and to the achievement of pre-identified design objectives.

The methodology facilitates performance-based design which meets the fire safety objectives of Amendment 7 of the Building Code of Australia (BCA) and also the indicated objectives, functional statements and performance requirements of the future PBCA (Performance-based BCA). The methodology also facilitates “equivalence evaluation” for alternatives to the prescriptive, deemed to satisfy requirements of the BCA or PBCA.

The outlined procedures recognise the designer may have to meet objectives additional to those of the BCA. Such other objectives could include the protection of property, business continuity and the corporate image of industrial and commercial buildings.

The indicated procedures equally recognise that specified design objectives can be achieved by a range of alternative and complementary fire protection strategies. Whilst these Guidelines provide selected data and engineering relationships for use during design activity, the use of alternative information (if available from a reliable and authentic source) is equally acceptable.

Many factors, including a building’s form of construction, means of escape, occupancy factors, smoke management, detection, alarm and fire suppression facilities, contribute to the achievement of fire-safety objectives. These Guidelines are based on the premise that all these measures form part of an integrated fire safety system for the building, which must respond to any fire developing within that building. Consequently, it is required that designers recognise the interactions between elements of a fire safety system and that they develop complete and integrated design solutions.

The basic principles outlined herein may be applied to all general types of buildings and their uses. However, this document does NOT provide guidance in respect to buildings which are used for bulk storage or processing of flammable liquids, industrial chemicals or explosive materials. The intrinsic risks associated with such buildings will necessitate special consideration and may well be beyond the scope of this document.

These Fire Engineering Guidelines are intended for application during the conceptual phase of building fire safety system design, prior to the design, specification and documentation phase of the selected fire-safety sub-systems (or elements). Fire engineering procedures require early consultation and co-operation between the project manager, architect and other members of the design team, together with the related building surveyor and fire authorities. The detailed design and specification of fire-safety sub-systems (which will follow agreement of the conceptual design) are not specifically referred to in these Guidelines but it is clearly imperative that when executed these strictly adhere to the decisions and agreements reached during the conceptual phase.

Adherence to these guidelines by a suitably qualified and experienced fire safety engineer will permit achievement of the requisite level of fire safety for a building, economically and without imposing unnecessary constraints on other aspects of its design.

Fundamentally, these Guidelines are intended for use by fire safety engineers, when acting as part of a building design team. Accordingly, they have been written to reflect the Australian building design process.

Nonetheless an important additional application is that these Guidelines are recommended for use by all levels of regulatory official (e.g. council and privately employed building surveyors, fire brigade officers, etc.) during assessment and checking of fire safety designs presented for approval.

In such circumstances it is recognised that on occasions building surveyors may require the assistance of fire engineering specialists during the assessment of complex performance based building fire safety designs developed under these guidelines. Such requirement only mirrors the situation which already applies in respect to the regulatory checking of structural and other complex engineering designs.

It is believed that where possible the qualification and capability of fire safety engineers should be accredited by an appropriate professional institution. The assumption within these Guidelines is that an appropriate fire safety engineer is a person, who by education, training and experience is:

- familiar with the nature and characteristics of fire and the associated products of combustion
- someone who has understanding of how fires originate, spread within and outside buildings/structures, and are detected, controlled and/or extinguished
- able to anticipate the behaviour of materials, structures, equipment and processes as related to the protection of life and property from fire
- able to use appropriate quantitative fire engineering methodology as well as understanding all the techniques utilised in respect to assumptions, limitations and uncertainties.
- aware of matters of fire safety management, including the role of fire prevention and the risks to building fire-safety associated with construction, installation, operation and maintenance.

These Guidelines cannot possibly detail all the engineering design technology required for use on every specific building fire-safety design. Rather, these Guidelines have been assembled to outline one recommended framework for such fire safety design activities.

For other detailed quantification methods and data, fire safety engineers are referred to the technical literature and to specific textbooks such as:

- The SFPE Handbook of Fire Protection Engineering, Di Nanno Ed., 1st Edition, NFPA/SFPE, Boston, (1988).
- Drysdale, D., "An Introduction to Fire Dynamics", John Wiley and Sons, London, (1985).
- Klote, J.H., & Milke, J.A., "Design of Smoke Management Systems", ASHRAE/SFPE, USA, (1992).

**CHAPTER 2**

**DEFINITIONS**

2.1 Definitions

**2.1 Definitions**

For the purpose of these Guidelines the following definitions apply.

**Available safe egress time (ASET)**

The calculated time available between ignition of a fire and the onset of untenable conditions in a specified part of a building.

**Calorific value**

The total amount of heat released when a unit quantity of a fuel (at 25 °C and atmospheric pressure) is oxidised during its complete combustion in oxygen.

**Clear width**

The total width of a corridor, stair, passage or doorway opening measured at its narrowest point.

**Critical fire load**

The effective fire load required in a compartment to produce a fire of sufficient severity to cause failure of fire resisting barriers or structural elements.

**Detection time**

The time between ignition of a fire and its detection by an automatic or manual system.

**Deterministic study**

A methodology, based on physical relationships derived from scientific theories and empirical results, that for a given set of initial conditions will always produce the same outcome.

**Effective fire load density**

The fire load within a room or compartment less a factor to take account of the incomplete combustion of protected fire loads and/or a reduction in the net quantity of heat released resulting from the presence of wet materials.

**Effective width**

The clear width of a stairway, corridor or opening less the thickness of a notional boundary layer.

**Equivalent fire load density**

The fire load density per unit floor area expressed as an equivalent mass of wood rather than in terms of its calorific value.

**Escape time**

The time at which the occupants of a specified part of a building are able to enter a place of safety.

**Evacuation time**

The time at which all of the occupants are able to reach a place of safety outside the building.

**Exit**

A doorway or other suitable opening giving direct access to a place of safety.

**Fire load**

The quantity of combustible material within a room or compartment measured in terms of its calorific value.

**Fire load density**

The fire load divided by the floor area.

**Fire safety manual**

A document detailing the fire safety management procedures that should be implemented on a continuing basis.

**Fire scenario**

For prescribed conditions associated with the ignition, growth, spread, decay and burnout of a fire in a building or a part of a building, a fire scenario is defined by specifying the calculated (or otherwise determined) times of occurrence of critical events relevant to each of the sub-systems under investigation.

**Flashover**

The rapid transition from a localised fire to the combustion of all exposed surfaces within a room or compartment.

**Flow time**

The time needed for all of the occupants of a specified part of a building to move to an exit and pass through it and into a place of safety.

**Hazard**

An event that in a particular set of circumstances has the potential to give rise to unwanted consequences.

**Management or manager**

The persons or person in overall control of the premises whilst people are present, exercising this responsibility in their own right as the owner, or by delegation.

**Means of escape**

Structural means whereby safe routes are provided for persons to travel from any point in a building to a place of safety outside of the building.

**Occupant capacity**

The maximum number of persons assumed to be present within a room or compartment for the purposes of design.

**Period of passage**

The time required for a group of escaping persons to pass a specified point within the escape route.

**Phased Evacuation**

A process by which a limited number of floors (usually the fire floor and the level above) is evacuated initially and the remaining floors are evacuated as and when necessary.

**Safe Place**

A place of safety within a building or within the vicinity of a building, from which people may safely disperse after escaping the effects of fire. It may be a place such as a road, open space (including an appropriate roof space), or public space.

**Pre-movement time**

The time interval between the warning of fire being given (by an alarm or by direct sight of smoke or fire) and the first move being made towards an exit.

**Protected fire load**

The quantity of combustible material that is unlikely to undergo complete combustion during a fire owing to its being held within containers that have a degree of fire resistance (eg. steel filing cabinets).

**Risk**

The potential for realisation of an unwanted event, which is a function of the hazard, its probability and its consequences.

**Smouldering fire**

A fire involving the surface oxidation of a material, producing little heat and no flames but having the potential to produce combustible gases that could fill a room with a flammable or explosive gas/air mixture.

**Travel distance**

The actual distance that needs to be travelled by a person from any point within a building to the nearest exit, having regard to the layout of walls, partitions and fittings.



<b>CHAPTER 3</b>	
<b>GENERAL - FRAMEWORK OVERVIEW</b>	
3.1	Introduction
3.2	General
3.3	Design Process
3.4	Conceptual Design
3.6	Fire Engineering Design Brief (FEDB)
3.6	Quantified Analysis
3.7	Fire Scenario Analysis
3.8	Evaluation
3.9	Reporting and Presentation
3.10	Design Approval
3.11	Implementation and Operation
3.12	Change of Use

### **3.1 Introduction**

This Guidelines document is structured to lead design engineers and checking authorities through the process of conceptual fire engineering design in a logical manner.

This Chapter provides an introduction to the framework (or methodology) and summarises key elements to familiarise users with the design processes of fire safety engineering for buildings and other facilities.

Chapter 4 describes the part of the design process that sets out the preliminary design issues and the form of analysis that should be agreed, on the one hand, between the designers and fire protection engineer and on the other, with the approval/checking authority(ies). In these guidelines this part of the process has been entitled the "Fire Engineering Design Brief (FEDB)".

To undertake the FEDB, a trial concept design for fire safety has to be undertaken. Guidance on design options for components that may be included in a trial concept design are detailed in Chapter 5.

A key element of the FEDB is to reach agreement between all parties as to the extent and form of analysis necessary to verify that the final package of fire safety measures meets their acceptance criteria. There are various options available and the methods by which such analyses can be undertaken are provided in Chapter 6 of these Guidelines. Chapter 6 also provides the basis for overall evaluation and acceptance of the fire safety design and the final reporting of the design.

Any analysis requires performance quantification of the sub-systems and components of the proposed fire safety system. Chapters 7 to 13 deal with the analysis of various sub-systems for input into the overall fire safety system evaluation described in Chapter 6.



## **Chapter 3 - General -Framework Overview**

Finally, there are a series of appendices that list relevant references and provide other information to assist in design.

### **3.2 General**

For buildings generally, the prescriptive (“deemed to satisfy”) fire safety design solutions as presented in the BCA will be found to be adequate, albeit conservative. A fire engineering approach that takes into account total building fire-safety can usually provide more fundamental and economic solutions, whilst for some large, complex building developments it may represent the only viable means of establishing acceptable levels of fire safety. Fire engineering, as described in these guidelines, will require more detailed consideration but will achieve much more appropriate, efficient and cost-effective designs for building refurbishments and for new and complex properties.

On many occasions fire safety design objectives will be identified that are additional or complementary to those of the BCA. For example, property protection has to be a key objective of many building owners and insurers, and continuity of operations is critical in facilities such as computer centres, telephone exchanges and control rooms. For older buildings, protection of Australia’s heritage may be an important objective. The fire engineer must develop a package of fire protection measures that addresses all these objectives.

Fire is an extremely complex phenomenon and despite significant advancements over the past 20 years there are still many gaps in available knowledge. It is still not possible to set down simple step-by-step fire safety design procedures that can be applied to all buildings. Accordingly these guidelines identify flexible but formalised procedures which should be pursued during performance-based building fire safety design activities and which can equally be followed by statutory authorities during assessment of submitted designs.

In respect to design activity, it is expected that normally these guidelines will be used by suitably qualified and experienced fire safety design engineers. The assistance of suitably qualified fire engineers is also recommended in those instances when regulatory and inspecting authority officers consider they have insufficient personal fire engineering expertise to adequately assess and approve performance-based, fire engineered designs. The ultimate decision for building approval is however clearly recognised as the role of the building surveyor and no one else.

The best designs will emerge from situations where a high level of trust and communication is established between all parties, at the earliest stage of a project. Statutory requirements must always be recognised and the advice of building surveyors and local fire authorities should be sought in respect to decisions regarding a building’s fire safety design.

### **3.3 Design Process**

These Guidelines recognise the building design process that is outlined in Figure 3.1. The Guidelines are intended for use during the conceptual stage of a project and are applicable to fire safety designs for both new and existing buildings. They can be used either to justify minor deviations from traditional regulations or to evaluate the building design as a whole.

## Chapter 3 - General -Framework Overview

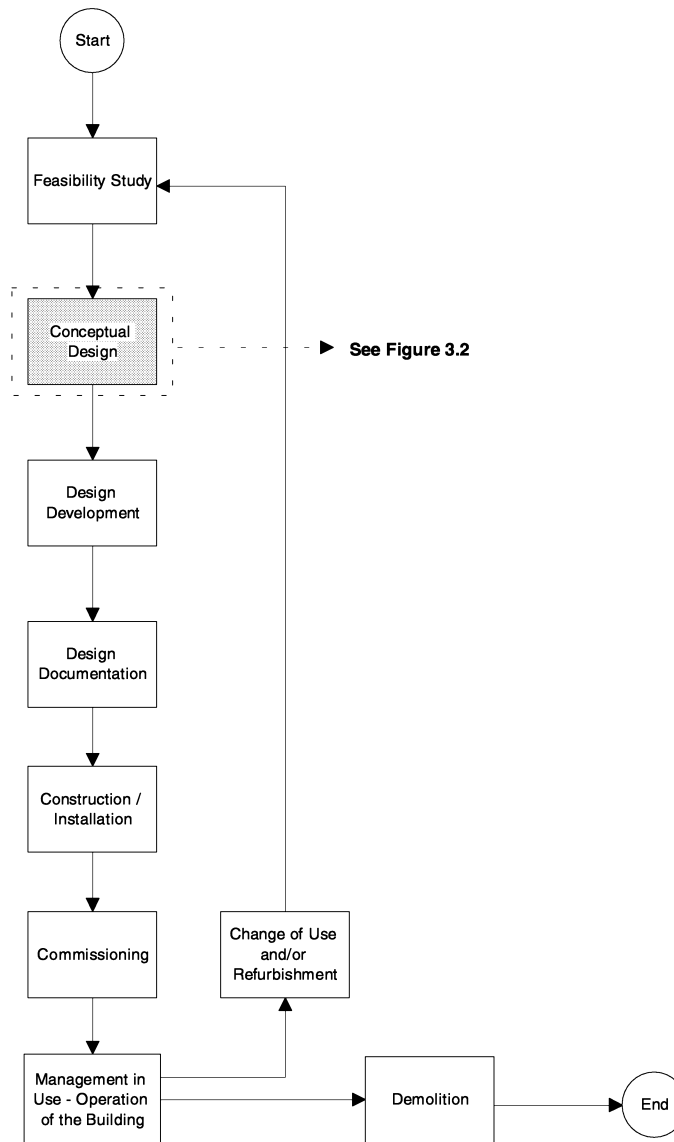

**Figure 3.1 Generalised Project Delivery Process**

When the conceptual design strategy has been developed and analysed to demonstrate to the satisfaction of all parties its compliance with the jointly established acceptance criteria, then the detailed design development and documentation stages of the process can commence. The processes of detailed design and documentation for construction and installation of fire safety sub-systems and components are not described in these guidelines but obviously during this work there must be strict adherence to the agreed conceptual design.

Following commissioning, the operation of the building must recognise and ensure that 'management in use' concepts incorporated in the original design are maintained for the life of the building. For example, if a design is based on prescribed levels of maintenance or regular evacuation drills, then administrative provisions need to be in place to ensure these activities are properly undertaken. When developing designs that are highly specific to a building and its immediate use, designers should be alert to the constraints that may be imposed on the building, if at a later stage there is a change of use. For any highly specific design, it is to be expected that administrative provisions will have to be imposed to ensure that occupancy and use remain consistent with the parameters assumed

## Chapter 3 - General -Framework Overview

at the time of design. If there is a change in use, then the design process should be repeated as illustrated in Figure 3.1.

### 3.4 Conceptual Design

For the fire safety design of a particular building, the conceptual design phase is split into 5 main steps:

- (a) fire engineering design brief (FEDB)
- (b) FEDB report
- (c) quantitative analysis and evaluation
- (d) identification of conceptual design package of fire safety measures
- (e) final fire safety systems report.

This conceptual stage of the design process is illustrated in Figure 3.2. The first two steps are qualitative and detailed quantitative analysis may or may not be required depending on the type and extent of the problem being addressed and the degree of fire safety design required.

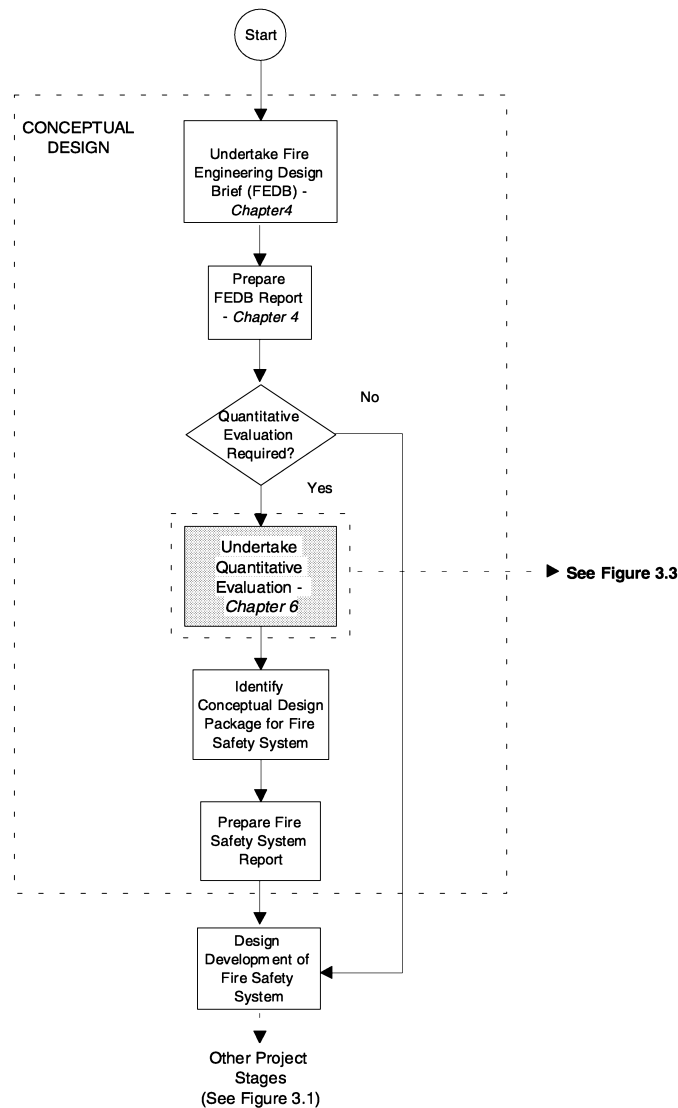

Figure 3.2 Conceptual Design Procedure for Fire Safety Design

### **3.5 Fire Engineering Design Brief (FEDB)**

Interaction between fire, buildings and people gives rise to many possible scenarios. This, in association with the wide range of building designs and uses, makes it impractical to establish a single set of calculations and procedures that can be applied directly to all buildings.

Before attempting to carry out a quantification study, the significant fire hazards of the building being considered should be identified; the problem should be simplified as far as is appropriate and the required extent of analysis should be established. Additionally, it is essential the chosen calculation techniques are appropriate to the problem under consideration, although for some problems little or no quantification may be required. Furthermore all these decisions should be acceptable to all parties. For these reasons a formalised design review and hazard assessment procedure is included. This procedure is termed the Fire Engineering Design Brief (FEDB).

The objective of the FEDB is to review the architectural proposals, identify potential fire hazards and define the fire safety problems in qualitative terms, suitable for detailed analysis and quantification. Another important function is to establish one or more fire protection arrangements (trial concept designs) that are considered likely to satisfy the fire safety criteria. On major projects, the Fire Engineering Design Brief should be undertaken by a group which includes members of the design team and one or more fire safety engineers. Equally it may be desirable for the building surveyor who will approve the design and a representative of the fire service to be involved.

Adoption of the “team approach” ensures that all aspects of the building’s design are considered in the context of the fire safety objectives and criteria. Furthermore, as tools for computation and data for quantification will not always be available, the application of engineering judgement by members of the team can play an important part during the FEDB.

The key elements of the Fire Engineering Design Brief process are to:

- (a) secure agreement from all parties to the design objectives and acceptance criteria;
- (b) establish trial concept design(s) acceptable to all parties; and
- (c) specify the requisite fire scenarios for analysis.

The FEDB team should establish whether or not a quantified analysis is necessary, and, if it is, the scope and level of quantification and analysis required.

The Fire Engineering Design Brief is best developed during the conceptual stage of a project whilst there is still flexibility in the building design or proposed refurbishment. The FEDB and its subsequent detailed analysis(es) will generate and validate an “agreed” conceptual fire safety system design package, which can be documented to form the basis of the detailed design and specification phases of the project.

### **3.6 Quantified Analysis**

#### **3.6.1 General**

Having established at the FEDB stage that a quantified analysis is required, then an analysis must be undertaken for each fire scenario specified and for each trial

## Chapter 3 - General -Framework Overview

concept design until one design package meets the acceptance criteria. This general process of quantification and evaluation is illustrated in Figure 3.3

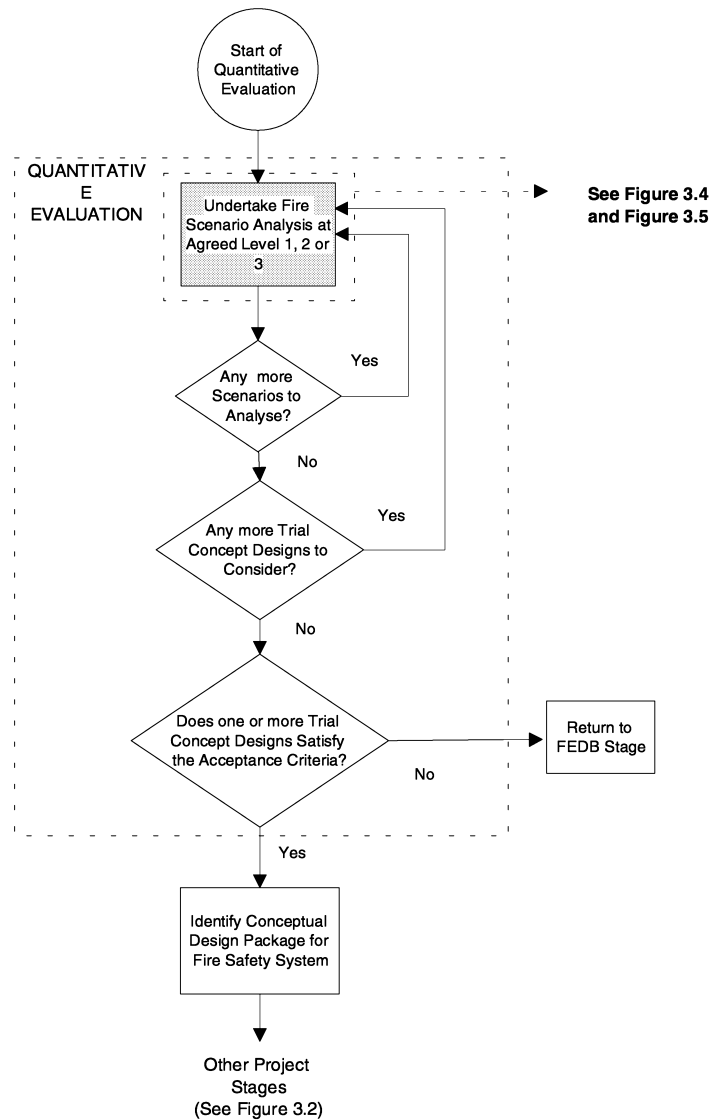

**Figure 3.3 Procedure for Quantitative Analysis**

It has been found convenient to split this quantitative scenario analysis procedure into a number of separate parts and experience has shown this is best done using the 6 sub-systems described in these guidelines. These are:-

- (a) sub-system 1: Fire Initiation and Development (refer to Chapter 8);
- (b) sub-system 2: Smoke Development and Management (refer to Chapter 9);
- (c) sub-system 3: Fire Spread and Management (refer to Chapter 10);
- (d) sub-system 4: Detection and Suppression (refer to Chapter 11);
- (e) sub-system 5: Occupant Avoidance (refer to Chapter 12).

## Chapter 3 - General -Framework Overview

- (f) sub-system 6: Fire Brigade Communication and Response (refer to Chapter 13)

The basic system of analysis is illustrated in Figure 3.4.

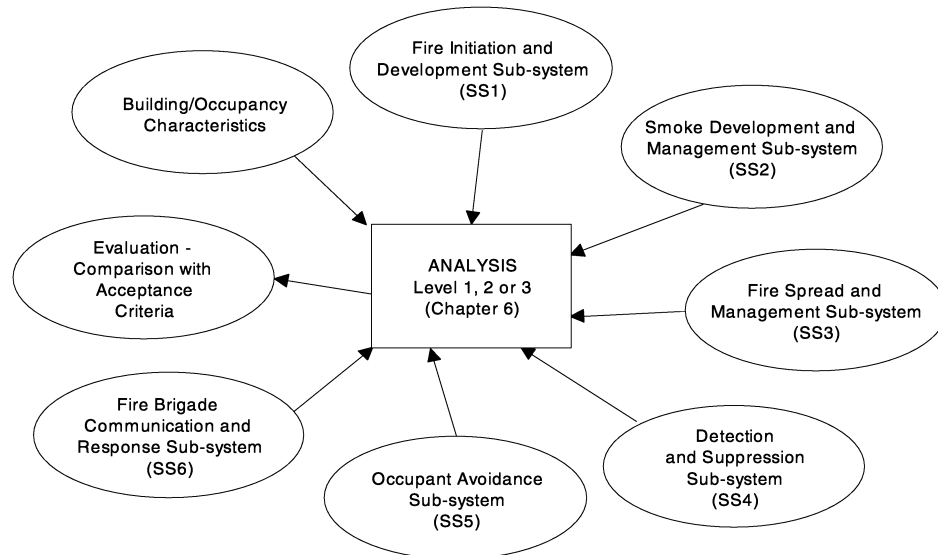

**Figure 3.4 System Evaluation**

Each of these sub-systems is dependent upon basic characteristics of the building and its occupants. (The means of determining those characteristics are detailed in Chapter 7).

The outputs of each sub-system SS1 to SS6 also go into the overall system analysis and the trial concept design is then evaluated against the acceptance criteria agreed in the FEDB. The overall analysis, evaluation and identification of an acceptable conceptual design package is undertaken in Chapter 6 of these guidelines.

In Chapter 5, in respect to each sub-system, design guidance is given which may be used to establish specific fire safety components for a trial concept design. Chapter 5 only identifies some options and suggested performance parameters. Designers should not feel limited to these, and as fire science and technology develops, other and more innovative options may be considered if appropriate to the building being designed or refurbished.

When analysing a particular aspect of a building's fire safety design, the appropriate fire safety sub-system may be considered individually. Alternatively if the analysis relates to an overall fire engineering evaluation of a building, all of the fire safety sub-systems should be considered in an integrated fashion. Within these guidelines, the several sub-system sections do not attempt to provide all the information which may be required for evaluation purposes, but they do present the general principles and procedures appropriate to the analysis of sub-systems within the general fire engineering methodology.

In the interests of simplicity it is inevitably necessary to include conservative assumptions in the design process and the sub-systems have been developed on

## **Chapter 3 - General -Framework Overview**

this basis. Accordingly, not all available research has been incorporated into the procedures outlined in these guidelines. For instance, no account is taken of the effects of smoke and toxic gases on the speed of people movement during the evacuation process. For simplicity a simple “go/no-go” situation is assumed: ie. that the occupants will either be able to escape relatively unimpeded or will be trapped due to the onset of untenable conditions. A more detailed analysis could be carried out, which would take account of the effects of visual and physical impairment. However, before embarking into such sophistication, particular care should be taken to ensure the validity of the initial assumptions (such as fire growth rate) justifies significant refinement of the modelling techniques.

At the FEDB stage, the level of analysis and form of evaluation must be decided. The means of undertaking such analysis is detailed in Chapter 6 but also summarised in the following sections.

### **3.6.2 Level 1 - Component and Sub-system Equivalence Evaluation (SEE)**

Where it is only required to establish that a selected component or sub-system provides at least equivalent performance to that specified by regulation (ie. in the “deemed to satisfy” requirements of the BCA), a form of comparative analysis may be used, termed Level 1 analysis in these guidelines. At this level only one sub-system is involved in isolation.

Such comparative analyses would typically use analytical calculations to demonstrate at least the “equivalence” (equivalent performance) of the proposed alternative component or sub-system. It would be typical of such a simplified analysis that only one fire scenario would be considered, normally the ‘worst credible’ scenario. This would normally involve applying the same models, calculations, input data, etc., for the acceptable solution and the alternative solution.

As an example, a Level 1 analysis and evaluation would be appropriate when considering an alternative fire detection system to that specified in the BCA. The alternative proposal may involve a different type of detection device, different spacing of detectors or other changes. Provided the alternative gave a detector alarm signal at an equal time or earlier, then the alternative proposal would be acceptable in performance terms.

Similarly, the BCA may specify a particular fire rated structural element as a ‘deemed to satisfy’ prescriptive solution. A different structural element or approach would be acceptable under a performance based design if the alternative can be shown to provide equivalent structural performance through a Level 1 analysis and evaluation.

### **3.6.3 Level 2 - System Performance Evaluation (SPE)**

When the whole or a substantial part of a fire safety system is being considered, then a more sophisticated analysis and evaluation is required that involves 2 or more sub-systems. This level of analysis needs to take account of the interaction between sub-systems and components. Such analyses may be based on a simple fire scenario and time line analysis, but may involve consideration in isolation of more than one “worst credible” fire scenarios. Designers are encouraged to analyse two or more fire scenarios to ensure a range of likely situations are covered.

## **Chapter 3 - General -Framework Overview**

Evaluation of performance may be on a comparative basis (ie. compared against an acceptable prescriptive design solution) or be measured in absolute terms.

In comparative analyses, identical scenarios have to be used and identical inputs, models etc. used in both analyses. Any assumptions regarding rate of fire growth or choice of fire model for calculation etc. are then unlikely to have a significant influence on the outcome.

Stemming from initiating assumptions and from errors in calculation procedures there are inevitable uncertainties in the absolute calculations associated with fire engineering design of building fire safety. Therefore, it may be appropriate to include explicit safety factors in such analyses to compensate. However, it is important to avoid using excessive safety factors as the basic assumptions and calculation procedures are known to be highly conservative.

Guidance on safety factors is given in Chapter 6 and it may be appropriate to adjust these according to the accuracy of the modelling techniques used. Higher safety factors may be appropriate when the consequences of a fire could be particularly severe. In particular, higher safety factors are recommended in the evaluation of tenability conditions when large numbers of the public are likely to be present.

The FEDB team should determine whether it is appropriate to include explicit safety factors within the evaluation being contemplated or whether the assumptions and calculation procedures are themselves intrinsically and sufficiently conservative.

Level 2 analysis and evaluation in comparative terms will be appropriate for most alternative design proposals that are not radically different from those included in the BCA or other traditionally accepted regulations. Such proposals only warrant a limited degree of analysis.

A typical example of a Level 2 evaluation is where a designer is developing a smoke management system to meet the Amendment 7 requirements of the current BCA. In this situation, the designer must evaluate aspects that include fire growth rates, smoke development, times for detection and suppression, smoke control performance and occupant egress. This design process involves a number of the sub-systems and therefore requires at least Level 2 analysis and evaluation.

Level 2 designs are inherently more conservative than Level 3 design solutions.

### **3.6.4 Level 3 - System Risk Evaluation (SRE)**

Level 3 analysis and evaluation is appropriate for major complex or highly innovative buildings in which substantial analysis could lead to significant cost savings or to solution of very difficult design problems.

Analysis and evaluation at Level 3 is also appropriate where the trial concept design is radically different from the currently accepted prescriptive solutions in the BCA.

The form of analysis at Level 3 is Probabilistic Risk Analysis (PRA) which demands a higher skill level from the fire engineer and is very complex in quantification. This form of analysis will also require greater assessment skill by the building surveyor and the technical specialists assisting.



## **Chapter 3 - General -Framework Overview**

By assigning probabilities of failure to the fire protection measures and assigning frequencies of occurrence to unwanted events, PRA can analyse and combine a number of different fire scenarios as part of a complete fire safety assessment of a building design. This use of multiple scenarios and their combination through probabilistic techniques is the key feature of a level 3 approach.

The great benefits of PRA are that it can:

- establish the most cost efficient design solution,
- provide a measure of the effect of the low probability, high consequence events,
- facilitate comparison of the effectiveness of dissimilar fire protection components (eg. sprinklers versus compartmentation),
- evaluate the effect of failure of one or more fire protection sub-systems.

The PRA technique requires availability of statistical data on fire events and on reliability/performance of fire protection sub-systems. It also requires determination of the “time to operate” and “time to failure” of those sub-systems that are involved in the fire models and other analytical tools used in Level 2 analysis.

An example of where a Level 3 evaluation would be appropriate would be a case where a major, large, new shopping centre was being designed using a radical approach. If the design proposed was using timber or unprotected steel structural elements and little or no compartmentation in combination with automatic sprinklers and innovative egress solutions, then the Level 3 evaluation would be the preferred approach. The risk assessment techniques is the only form of analysis suited to radically different alternatives.

Given the amount of statistical data and analysis required for a full PRA, and given the present state of the art, a Level 3 analysis should only be undertaken on a comparative basis, and not in an absolute sense.

Whilst other more developed fields of engineering use PRA on an absolute basis, for building fire engineering it will be some years before PRA has been developed to the stage where it can be used to estimate lives lost/building/annum and compare this against some agreed community standards eg. acceptable rate of fire deaths, property damage and risk to fire fighters.

### **3.7 Fire Scenario Analysis**

If quantification is agreed as necessary, then the FEDB process will have defined:

- the acceptance criteria
- trial concept design(s)
- the level of analysis and evaluation
- fire scenarios to be analysed.

The analysis of scenarios is the core of these guidelines, with each sub-system analysis being outlined in chapters 8 to 13 and the final evaluation of an acceptable design package detailed in Chapter 6.

Each scenario should be analysed in a logical and consistent manner. This process of analysis can be highly complex and iterative. One approach to fire scenario analysis is illustrated in Figure 3.5.

## Chapter 3 - General -Framework Overview

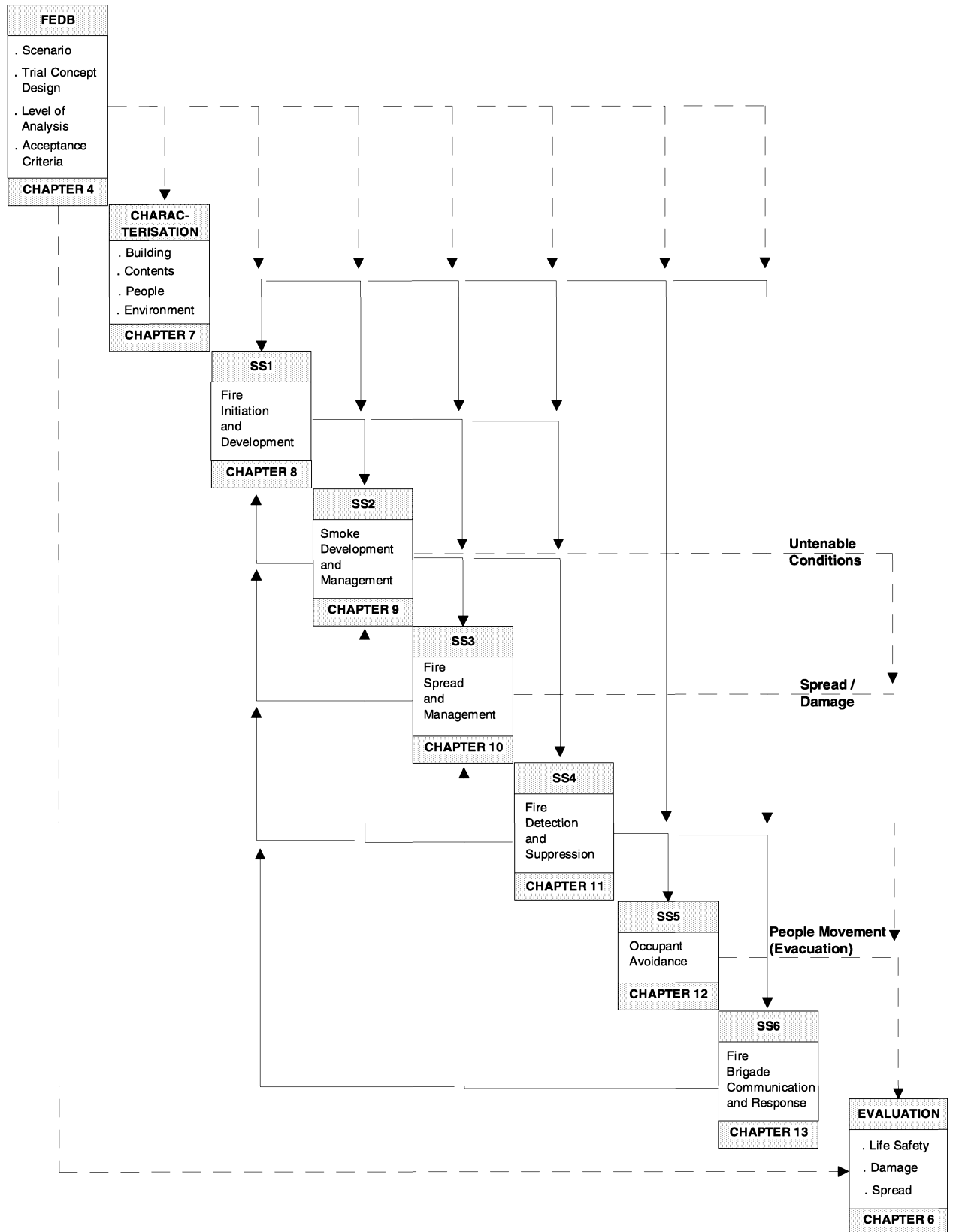

**Figure 3.5 Fire Scenario Analysis Showing Typical Interaction Between Sub-systems**

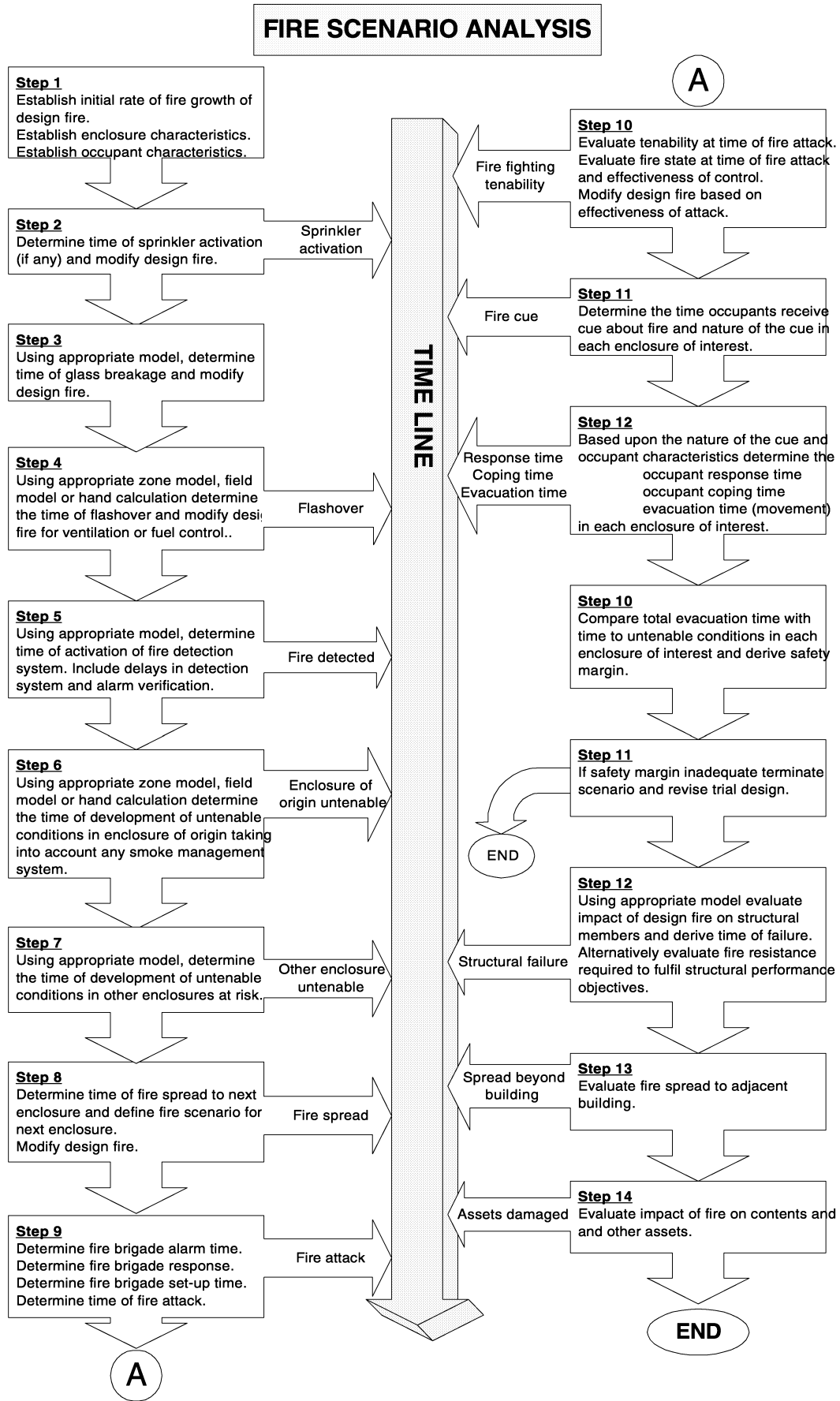

Figure 3.6 Fire Scenario Analysis

## **Chapter 3 - General -Framework Overview**

The Figure 3.5 shows the FEDB (Chapter 4) and Characterisation (Chapter 7) feed into each of the sub-systems. These sub-systems in turn provide outputs, into a final overall system's analysis and evaluation (Chapter 6). These outputs are usually times of key events (and probabilities for a level 3 design) that form the basis of evaluation of an acceptable fire safety system design package.

Another means of illustrating this process of analysis for fire scenarios is shown in Figure 3.6. This is typical only, but provides one logical order of calculation steps for a level 2 evaluation. It shows the outputs of each step going onto a scenario timeline that forms the basis for all levels of analysis and evaluation. The order of events will be entirely scenario dependent and Figure 3.6 is illustrative only.

Designers should be aware that the process of fire scenario analysis outlined above is only one approach. Particular designs may involve only some sub-systems, or additional or different linkages between sub-systems may be required. Totally different division of fire safety elements into other sub-system arrangements are also possible provided it is logical and systematic.

Specific flow charts for six sub-systems are provided within the chapters 8 to 13. These flow charts highlight the inputs required, the outputs and the means of analysis. The connections between sub-systems in terms of data flow are detailed in Appendix 3A.

### **3.8 Evaluation**

The evaluation of each fire scenario and trial concept design is undertaken in Chapter 6 of the guidelines.

The means of evaluation depends on the level of analysis.

For level 1 and 2 analysis, the times of key events are placed on a timeline to determine whether an acceptable safety margin is achieved. For each enclosure of interest, the critical events are time to safety (evacuation, typically) and time to untenable conditions. This is illustrated in Figure 3.7

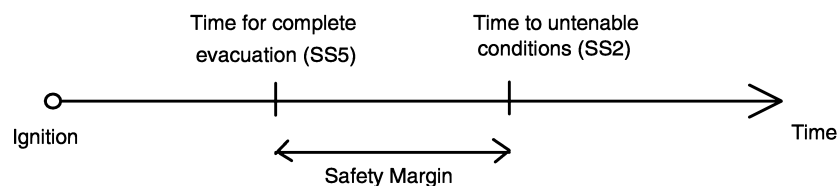

**Figure 3.7 Typical Timeline Evaluation**

The design is acceptable if sufficient safety margin is provided for all fire scenarios considered. There may also be other acceptance criteria to meet, such as limits on property loss or business interruption.

For a Level 3 design, the evaluation is more complex. Timelines similar to Figure 3.7 are required for each fire scenario. However, probabilities are also required for an event tree analysis that ultimately determines two critical parameters:

- i. expected risk to life (ERL)
- ii. fire cost expectation (FCE)

## **Chapter 3 - General -Framework Overview**

An acceptable alternative design is one that generates an ERL and FCE that are less than ERL and FCE figures for a prescriptive design. For example, if a design of a BCA complying building generates specific ERL and FCE figures, then an alternative building design that is acceptable should have an equal or lower risk to life and be no more costly than the BCA building.

### **3.9 Reporting and presentation**

Most buildings designed in accordance with these guidelines will be subject to review and approval by building surveyors or by statutory bodies. It is therefore essential the findings of the fire safety study and evaluation, together with any assumptions made, be presented in a form that can be clearly and readily understood by others.

These guidelines do not recommend a fixed format for the report but it is recommended the minimum information to be presented should include:- the findings of the FEDB study; details of all assumptions; references; engineering judgements; methodologies employed; analyses undertaken; sensitivity analyses and comparisons of results against acceptance criteria.

“Management in use” matters including construction / operation / maintenance issues that are an integral part of the design must be fully detailed in the report.

### **3.10 Design Approval**

In Australia a building surveyor, either as a council officer or as a private certifier, will most likely be responsible for assessment and approval of the building fire safety system designs developed in accordance with these guidelines.

Currently it is likely the building surveyor will have to refer the submitted design to the State based appeals process, as amendment or modification of legislated BCA provisions will most probably be involved. This procedure will clearly be hastened if the design team has consulted closely, throughout the conceptual design period, with the appropriate council / building surveyor and the fire brigade, particularly if the design concept and quantification methodology has been validated to them.

In the not too distant future, when the proposed Performance-based BCA is implemented, it is anticipated that building surveyors who are suitably qualified and who are assisted by appropriate fire engineering specialists as necessary, will certify performance-based fire-safety designs without resort to the legal appeals process.

For some projects there is not a requirement for regulatory approval, if the work involved is limited in scope, intended to up-grade part of the building only or to provide additional protection to property, contents or specialised equipment. In these cases acceptance of the design strategy by the building owner and insurer should be sought.

### **3.11 Implementation and Operation**

Once the conceptual design package of fire safety measures is approved, then the subsequent stages of design should ensure that the design documentation, installation and commissioning reflect the agreed concept design.

## **Chapter 3 - General -Framework Overview**

To ensure performance based designs are properly implemented, the original fire safety engineers should be involved at each stage of the design delivery process outlined in Figure 3.1.

Once in operation, it is equally important that the building be managed in accordance with the assumptions incorporated in the conceptual design. If the design included specific operational, maintenance and people management features, then there should be a mechanism to ensure these features are properly 'managed in use'. For example, if a design incorporated a shorter time for evacuation, based on regular evacuation drills of occupants, then there should be controls in place to ensure these drills are conducted at the specified intervals and meet the original design criteria. Mechanisms used to ensure buildings are managed in accordance with the conceptual designs should be to a recognised standard such as ISO9000 or similar.

### **3.12 Change of Use**

If the use of a building is altered or other assumptions built into a performance based design are changed, then the fire safety design of a building should be re-examined.

This re-evaluation requires recognition by building owners and appropriate administrative provisions to ensure it occurs. It is critical to the life of a building and its fire safety system. If changes of use or other factors alter to affect long term fire safety performance, then issues of liability may arise if this fire safety re-evaluation does not occur.



<b>CHAPTER 4</b>	
<b>FIRE ENGINEERING DESIGN BRIEF</b>	
4.1	General
4.2	Design Objectives
4.3	Acceptance Criteria
4.4	Hazard Identification
4.5	Fire Scenarios
4.6	Trial Concept Design
4.7	Methods of Evaluation
4.8	Design Documentation and Reporting
4.9	Detailed Design and Documentation

### **4.1 General**

The implementation of a rational fire safety design requires definition of its operationally specific goals and constraints. Whilst a general requirement for adequate fire safety is satisfactory as a universal goal, designers need specific performance criteria to evaluate the acceptability of design solutions. Standardised fire safety criteria that address actual performance are being developed in Australia by the FCRC in consultation with the Australian Building Codes Board (ABCB) but may be some time before being completed for all occupancy categories. Meantime, a new performance-based BCA is being circulated in draft form for public comment. As a result, use of quantitative fire analysis may be somewhat restricted in practice until after the new performance based BCA is published. Nonetheless even now quantitative fire analysis remains a valuable tool and provides better insight for design decision-making.

Traditionally fire safety goals have been defined in terms of pass-fail criteria specified in building and fire regulations. Frequently these criteria are in terms of fire indices (eg., flame spread ratings), which do not describe or appraise the fire hazard or fire risk of a product's performance under actual fire conditions. Pass-fail criteria such as these have difficulty addressing important factors of fire safety, including:

- (a) The transient characteristics of fires;
- (b) The transitory placement of combustibles in buildings;
- (c) The number of possible ignition and fire scenarios;
- (d) Differences in damage susceptibility and vulnerability;
- (e) The continuous nature of hazard and damage caused by fire.

In other words, it is difficult for such criteria to address the specific context of product use, but it is just this context that determines the actual hazard represented by a product. Quantitative fire engineering provides a means to evaluate the fire performance of a building within a particular application. Figure 4.1 shows the design process flow chart and details the several stages of the Fire Engineering Design Brief (FEDB) process.



## Chapter 4 - Fire Engineering Design Brief

This Chapter 4 sets out in detail the FEDB stages that should be followed before detailed analysis and evaluation is undertaken.

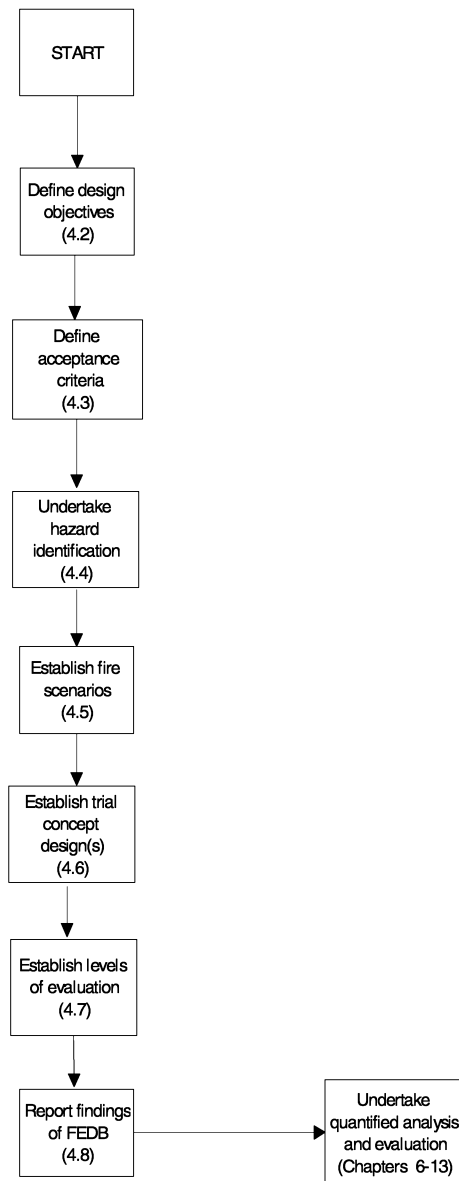

**Figure 4.1 FEDB Process Flow Chart**

### 4.2 Design Objectives

#### 4.2.1 General

These guidelines may be used either to develop and assess a complete fire safety strategy for a building or to consider one aspect of its design. Equally, the guidelines may be applied to the design of a new building or the refurbishment of an existing one. It is therefore important to establish that the identified objectives and acceptance criteria are appropriate to the particular aspect(s) of design under consideration and that they meet the requirements of the building regulations and fire authorities, as well as any applicable risk management and insurance requirements. For new buildings, compliance with the fire safety requirements of the BCA is required. For existing

## **Chapter 4 - Fire Engineering Design Brief**

buildings establishing that the building meets an appropriate and reasonable level of fire safety is the criterion.

The major fire safety objectives that may need to be considered in any design exercise are detailed in the following sections. However, the list is not exhaustive, and special considerations that should be taken into account by the fire engineer may apply for specific buildings.

### **4.2.2 BCA Objectives**

For many buildings, the fire safety system needs to be shown to meet the objectives of the Building Code of Australia (BCA), which are to protect:-

- life safety of occupants - the occupants must be able to leave the building (or remain in a safe refuge) without being subject to hazardous or untenable conditions.
- life safety of fire fighters - fire fighters must be given a reasonable time to rescue any remaining occupants before hazardous conditions or building collapse occurs.
- adjacent buildings - structures must not collapse onto adjacent property, and fire spread by radiation should not occur.

The issue of property protection as an objective of the BCA may need to be clarified by direct contact with ABCB.

Under current provisions, the building surveyor must be satisfied that a performance based design provides at least equivalent life safety and protection in terms of these objectives as would a comparable BCA complying design.

When the new performance based BCA is published, building surveyors may have to certify that the building and its fire safety systems meet performance requirements that reflect the objectives and functional statements set out for each section of the regulatory document.

### **4.2.3 Loss Control Objectives**

The effects of a fire on the continuing viability of a business can be substantial and disastrous. Many building owners have risk management programs and loss control measures that aim to limit fire damage and disruption. Loss control objectives that may need to be taken into account in a building fire safety system design include:-

- (a) limiting structural and fabric damage to a building
- (b) limiting building contents and equipment damage
- (c) maintaining business operation and financial viability
- (d) protecting corporate and public image.
- (e) protecting Australia's heritage in older or significant buildings

These objectives may also be a requirement of a building's insurers.

## **Chapter 4 - Fire Engineering Design Brief**

### **4.2.4 Fire Brigade Objectives**

Fire brigades are obligated by their Legal Charters to protect life and property. Regard must be had to this broader objective of the nation's fire brigades, with its linkage to risk management and insurance objectives.

### **4.2.5 Environmental/Community Protection**

A major conflagration involving several buildings and causing release of large quantities of hazardous materials can have an adverse environmental and community impact that is out of all proportion to the size of the fire.

Design consideration may have to be given to objectives which include the following:

- (a) the effects of fire on the surrounding community
- (b) the release of hazardous materials into the environment
- (c) disruption to community life and damage to the local economy as a result of a major fire.

Such objectives may be a requirement of legislation or of Environmental Impact Statements applicable to major building complexes and industrial plants and may require analysis by probabilistic risk assessment (PRA) methodology.

## **4.3 Acceptance Criteria**

### **4.3.1 General**

Whatever measures are taken to reduce the consequences of fire the possibility of death, injury or damage cannot be totally eliminated. It must be recognised that there is no such thing as zero risk. It is therefore important within the FEDB to establish the acceptable criteria against which the adequacy of any developed designs will be judged. It is usual for life safety that the risk to life be equal to or less than that inherent in the BCA. It is equally important that all parties agree to these criteria and the means by which an acceptance design is evaluated before any detailed design or analysis is undertaken.

The three levels of evaluation provided for in these guidelines are as follows:

- Sub-system Equivalence Evaluation (SEE) - Level 1  
Comparative Performance of a Component/Sub-system:  
Single/Multiple Fire Scenarios
- System Performance Evaluation (SPE) - Level 2  
Single/Multiple Fire Scenario(s)
- System Risk Evaluation (SRE) - Level 3  
Multiple Fire Scenarios in combination

For each of these 3 Levels, it is theoretically possible to establish design adequacy by means of two different approaches:

- (a) comparison of performance against another agreed design (concept of equivalence),  
or

- (b) absolute measurement of performance against agreed performance criteria and safety factors.

In these guidelines not all the alternatives of design level and approach are recommended.

### **4.3.2 Comparison of Performance**

The absolute design technique is obviously not applicable to a Level 1 evaluation as described in these guidelines and which is restricted to comparative performance of a fire safety component or sub-system. For Level 3 evaluation the absolute type of analysis is not currently recommended given the present state of knowledge of probabilistic risk analysis for fire safety design of buildings.

The acceptability of a particular design in Level 2 and 3 analysis may be evaluated by means of comparison. In such cases, the level of safety provided by alternative fire safety strategies is usually compared against the level of safety achieved in an identical building when its fire safety system is designed in compliance with the current prescriptive requirements of the BCA. Usually an additional design criterion is that the cost of the alternative fire safety provisions should be less than, or at least equal to, the cost of provisions required by the BCA.

This comparative approach or establishment of equivalence will generally involve timeline analysis (Level 2) or probabilistic techniques (Level 3), but will require less extensive analysis than an absolute study. In a comparative analysis, it should not normally be necessary to include safety factors within the calculation procedures. Any inaccuracies in the assumptions made for fire load, growth rate and other parameters will generally have less effect upon the outcome than in an absolute analysis.

For comparison purposes, life safety of occupants and fire fighters can be compared by time dependent or probabilistic criteria that are identified in sections 4.3.3 and 4.3.5. These criteria include:

- hot layer height
- heat radiation
- convected heat
- toxicity
- visibility / smoke obscuration
- expected risk to life (ERL)

For protection of adjoining property, the analysis will need to show that the radiation to an adjoining building is no greater than for a BCA complying design and that structural stability (usually expressed in FRL terms) is equivalent between the two designs. Radiation that can cause fire spread is usually expressed in units of kW/m<sup>2</sup>. Adjoining property may also be a fire source feature for the building being designed and radiation criteria may need to be considered and satisfied for the threat from adjoining buildings.

### **4.3.3 Level 1 Acceptance Criteria**

Sub-system Equivalence Evaluation (Level 1) requires firstly the identification of the basic performance requirement (eg. time of operation or failure) of the component or of the sub-system (when acting in isolation). It is not necessary to consider the effect of the component or sub-system on the safety of the occupants. The performances of the proposed and regulatory prescribed components and sub-systems need to be quantified in terms of the time of operation (eg. for a smoke detector) or the time of failure (eg. for a barrier). The criterion for acceptance is that the time of operation or failure of the proposed

## **Chapter 4 - Fire Engineering Design Brief**

component or sub-system must be the same or better than the performance of the regulatory prescribed component or sub-system.

### **4.3.4 Level 2 Acceptance Criteria**

#### **4.3.4.1 General**

In a Level 2 evaluation, the overall fire safety system must be assessed against a range of criteria based on analysis of one or more 'worst credible fire scenarios'.

The most important criteria is life safety of occupants and in Level 2 it is usual to evaluate life safety utilising the Available Safe Egress Time (ASET) principle, ie. using a time line technique to ensure that occupants have completed evacuation or reached safe refuge before untenable conditions have been reached. It is, therefore, important in a Level 2 evaluation to define and agree the acceptance criteria for untenable conditions during the FEDB process. In addition, if absolute rather than comparative analysis is to be undertaken, it is important to decide on appropriate safety factors and how to address uncertainties in modelling and calculation.

Having agreed untenable conditions, other criteria for the protection of property, protection of fire fighters, etc. should also be agreed, and equally the general engineering aim of achieving the desired fire safety system at optimum cost should be recognised.

#### **4.3.4.2 Life Safety Criteria**

The subject of limits of tenability for occupants in fire is very complex and this document can provide a guide only in any particular design situation.

Fire safety engineers are referred to the technical literature such as the extensive Chapter (2/8) by Purser on toxicity assessment in the SFPE Handbook (Purser : 1988).

- **Hot Layer Height**

For some buildings, particularly those with large, high spaces such as warehouses and atria, an acceptance criteria may be that the hot layer does not fall below 2100 mm in height from the floor. This means that occupants will not have to move through products of combustion (smoke) in making their escape.

In this approach, the only additional criteria required is that of radiation from the hot layer.

- **Heat Radiation**

The limiting condition for radiant heat from a hot layer or other fire condition should be taken as 2.5 kW/m<sup>2</sup> for design purposes. This accords with data in Table 4.1.

Table 4.1 Limiting Conditions for Tenability Caused by Heat Radiation

Radiation Intensity	Tolerance Time
< 2.5 kW/m <sup>2</sup>	> 5 min
2.5 kW/m <sup>2</sup>	30 sec
10 kW/m <sup>2</sup>	4 sec

## Chapter 4 - Fire Engineering Design Brief

For smaller enclosures of relatively low height, this limit of 2.5 kW/m<sup>2</sup> occurs when the hot layer reaches approximately 180 - 200 °C.

For some buildings, the simple approach of layer height and radiation flux / temperature is not appropriate. An example is a bedroom and corridor situation in a residential occupancy. In this case, smouldering and flaming may occur, and occupants may have to make their escape through smoke conditions. Under these circumstances, other acceptance criteria for life safety should be invoked that address the following:

- **Convected Heat**

Breathing of fire gases can cause heat stroke (or hypothermia). Convected heat can also cause skin burns. In both cases the degree of saturation of the air by water vapour is important.

Table 4.2 provides some useful data on convected heat.

**Table 4.1 Limiting Conditions for Tenability Caused by Heat**

Temperature / Humidity Conditions	Tolerance Time
< 60°C saturated	> 30 min
60°C, < 1% H <sub>2</sub> O	12 min
180°C, < 1% H <sub>2</sub> O	1 min

For most buildings, a temperature limit of 100°C is reasonable for exposure to convected heat. However, for particularly susceptible occupants, such as hospital patients, where escape times will be long, consideration should be given to using 60°C as one life safety criteria.

- **Toxicity**

The effects of fire products of combustion on humans is complex, with contributions coming from the asphyxiants (eg CO, CO<sub>2</sub>) and irritants (eg HCl, SO<sub>2</sub>) that are roughly additive.

The accumulated dose of toxic products can cause incapacitation (loss of consciousness) or death (lethality). The maximum tolerable doses of toxic gases for survival (lethal limits) are approximately twice those for incapacitation.

For engineering purposes, it is suggested that limiting conditions for all toxic products (asphyxiants and irritants) are unlikely to be exceeded for up to 30 minutes if the smoke optical density (OD) does not exceed 0.1 m<sup>-1</sup> (ie. 1.0 db/m).

For analysis in greater depth, the concept of fractional effective dose (FED) may be used for both asphyxiants and irritants. Suggested exposure doses (concentration x time) and peak concentrations are detailed in Appendix 4A that is referenced from the latest draft British Standard. This suggests, for

## Chapter 4 - Fire Engineering Design Brief

example, an exposure dose for incapacitation by carbon monoxide (CO) of 15,000 ppm.min.

- **Visibility / Smoke Obscuration**

Higher levels of smoke will obscure visibility and affect way finding and decision making during escape.

For small rooms, the minimum visibility acceptable for escape is 5.0 meters (OD = 0.2 m<sup>-1</sup>). At this limit, people behave in irritant smoke as in darkness.

For larger rooms, it is necessary for people to see further in order to orient themselves and find exits. People are also reluctant to enter heavily logged escape routes. To provide reasonable way finding and avoid toxicity problems, the minimum visibility in large spaces should be not less than 10 meters (OD = 0.1 m<sup>-1</sup>).

These tenability limits for smoke obscuration are detailed in Table 4.3

**Table 4.3 Tenability Limit for Smoke Obscuration**

Location	Minimum Visibility	Equivalent Optical Density (m <sup>-1</sup> )	Equivalent Optical Density (db/m)
Small rooms	5 m	0.2	2.0
Other rooms and spaces	10 m	0.1	1.0

### 4.3.4.3 Loss Control Criteria

In an absolute Level 2 analysis, acceptance criteria for damage to structure, fabric or contents of a building are usually expressed in dollar terms provided from an owner's or occupier's risk management and loss control financial assessments..

The owner's insurance company may be prepared to provide advice regarding "acceptable limits of loss", which in monetary terms would be expressed as Normal Loss Expectation (NLE) and may be related to an insurance deductible.

Corporate or public image is an intangible and clearly most difficult to quantify but many building owners who are 'risk averse' translate this criteria into acceptance of smaller losses than might otherwise be accepted as design criteria.

### 4.3.4.4 Environmental/Community Criteria

In an absolute Level 2 study, acceptance criteria in this area are usually values set by Planning, Flammable Goods or Environmental legislation. Indicative requirements are:

- (a) Radiation from building or plant to other buildings or surrounding community not to exceed 10 kW/m<sup>2</sup> (or some other agreed figure)
- (b) Explosion over-pressures not to exceed a specified limit.

## **Chapter 4 - Fire Engineering Design Brief**

- (c) Concentrations of hazardous chemicals not to exceed a specified fixed concentration in the event of an accidental release, due to fire or other causes.

No acceptance criteria for economic loss to a community as a result of fire are known, but these could be established in consultation with the appropriate community authorities.

Designers should note that fire spread between buildings is addressed in Chapter 10 and Appendix 10A of these Guidelines. Guidance is provided on radiative ignition giving a range of ignition values from 10 kW/m<sup>2</sup> to 40 kW/m<sup>2</sup>, depending on the target materials likely to be ignited.

### **4.3.5 Level 3 Evaluation Criteria**

#### **4.3.5.1 General**

When undertaking a Level 3 system risk evaluation (SRE), the aim is usually to show that the likelihood of a given event (eg. injury, death or damage) is acceptably small.

However, as Level 3 analysis is currently only recommended to be undertaken on a comparative basis, an acceptable design is one in which the risk of death, injury and/or damage is equal to or less than the risk applicable to a BCA or other code complying design.

#### **4.3.5.2. Life Safety Criteria**

For any proposed alternative design in a probabilistic, multi-scenario Level 3 analysis, the criterion of Expected Risk to Life (ERL) should be equal to or less than the ERL achieved by a BCA complying design.

At this stage of development of fire science and engineering, the use of Probabilistic Risk Analysis (PRA) methodology to evaluate absolute values for the risk of death or injury to individuals or groups within buildings is not encouraged. However in the future it will be possible to use PRA to establish acceptable levels of risk for building fire safety, in similar manner as the technique is currently used within other complex fields of engineering.

#### **4.3.5.3 Loss Control Criteria**

In probabilistic terms, the probability of loss (to varying degree) can be combined with monetary loss under various fire scenarios to assess "expected losses".

In a comparative study this is expressed as the Fire Cost Expectation (FCE). In the future, this criterion may need to be assessed by absolute study and be expressed as an acceptable, financial loss, in dollars, limited to the insurer's Normal Loss Expectancy (NLE) figures.

#### **4.3.5.4 Environmental/Community Criteria**

The risk of a new building complex or industrial plant on the surrounding community is commonly expressed in absolute terms by means of probabilistic risk assessment (PRA), as "the probability of death for an individual per year". In future, such PRA criteria may be established for building fire safety design, but until such time as this occurs it is recommended PRA be restricted to comparative ERL / FCE analyses for persons within a building.



There are no known probabilistic criteria for community economic loss.

### **4.4 Hazard Identification**

As part of the FEDB, systematic review to establish potential fire hazards should be conducted of the building proposed for analysis,. The review should take account of factors such as:

- (a) general layout;
- (b) potential ignition sources;
- (c) nature of the activities;
- (d) anticipated or existing occupancy;
- (e) materials of construction;
- (f) combustible contents;
- (g) any unusual factors.

This list is not exhaustive and the FEDB team should identify all significant fire hazards. When assessing the significance of each fire hazard, the FEDB team should take particular account of its influence on achievement or otherwise of the agreed fire safety objectives.

During this hazard identification stage, the FEDB team should consider the possible consequences of failure(s) in the fire protection sub-systems and management procedures, eg. fire doors left open or the smoke detection system being inoperative. In a Level 3 System Risk Evaluation, using probabilistic risk assessment (PRA), the likelihood and consequences of such failures will generally be quantified. However, in a Level 2 study, the team should make a judgment as to what represents a credible scenario for the purposes of detailed analysis.

Where the building facilities include a comprehensive fire safety management and maintenance plan which is subject to third party review, the benefits of this should be taken into account during assessment of the likely efficiency of the evacuation process and the reliability of installed fire protection systems.

### **4.5 Fire scenarios**

In these Guidelines, a fire scenario is defined (see definitions) as the complete description of a building fire from ignition to burn out, including the times of occurrence of all key events. At the FEDB stage, the task is to define and describe the fire scenarios to be quantified.

The number of possible fire scenarios in a complex building can be very large and often there are neither the data nor the resources available to attempt to quantify them all. The detailed analysis and quantification should therefore be limited to the most significant fire scenarios.

The characterisation of a fire scenario for analysis purposes should involve a description of such things as the initiation, growth and extinction of fire, together

## **Chapter 4 - Fire Engineering Design Brief**

with the likely smoke and fire spread routes. The possible consequences of each fire scenario should also be considered.

Where alternative fire safety design strategies are being compared against a reference case (ie. in a comparative study), the quantification can often be simplified considerably. In such instances it may only be necessary to consider a single fire scenario if this will provide sufficient information to evaluate the relative levels of safety of the trial design and the reference case.

The FEDB team should identify the important fire scenarios and those that can be neglected (eg. whether a very rare fire with the potential to cause a large loss is more or less important than small fires having a higher probability of occurrence but with potential to produce a similar loss over time). When establishing the sequences of events to be considered, the FEDB team should also take account of the possibility of failures of protection systems and management procedures (see 4.6).

In a level 2 absolute or comparative study it would be usual to identify a number of worst-case scenarios for analysis and evaluation. However, care and judgment should be used to avoid analysing events with a very low probability of occurrence. Furthermore, the FEDB team should not request detailed analysis and quantification where the outcome is obvious.

Chapter 6 provides guidance on the detailed development of fire scenarios. The FEDB team should describe the scenario(s) in sufficient detail to facilitate their quantification. In particular, the characteristic fire profiles expressed in heat release rate terms are an integral part of scenario specification. However, it may be that some aspects of particular scenarios cannot be described a priori and require detailed quantification before they can be considered. For example, the time of window breakage and the effect of the increased ventilation on fire growth requires detailed calculation. Similarly, whether sufficient fire-load exists to set off automatic sprinklers in a high roofed shopping mall requires analysis.

### **4.6 Trial Concept Design**

In many cases it will be necessary to amend the architectural design or provide additional fire protection measures to achieve an acceptable level of safety. The FEDB team should establish one or more trial concept designs (fire protection strategies) for more detailed analysis and quantification to enable all reasonable options to be considered.

There can be no hard and fast rules for the specification of alternative fire protection strategies. The members of the study team should use their knowledge and expertise to make sensible judgments on the suitability of various alternatives. Whilst under or over specification will be identified in the quantification process which follows the FEDB, both can waste significant time and it is clearly desirable the FEDB team be sufficiently experienced to be able to identify those cost-effective strategies that are likely to satisfy the fire safety objectives and criteria.

The question of what redundancies should be taken into account during evaluation should be clearly identified for each trial concept design developed,.

There are factors other than fire safety that determine whether a particular design is acceptable or not. Consideration of these may well rule out some of the proposed fire safety designs and thus simplify the subsequent quantification phase. Several alternative concept designs should be compared with each other in terms of cost and practicality. The FEDB team should be able to broadly estimate the costs of different strategies and eliminate expensive options from the

## **Chapter 4 - Fire Engineering Design Brief**

study. Certain fire protection strategies may present design, constructional or operational difficulties. If the fire protection requirements of any options compromise the speed of construction or the day-to-day operation of the building they are likely not to be cost-effective. Care should be taken to ensure any trial designs presenting significant practical difficulties are eliminated, if at all possible.

There is always the risk that the FEDB team can lose sight of practicalities and specify expensive measures to guard against unlikely hazards. To counter this tendency, questions should be asked as to how often the hazard is likely to occur and how serious the consequences would be. Sometimes a fully quantified analysis will be required but often, a problem can be brought into perspective by logical comparison or a few simple calculations.

Most FEDB teams are likely to be comprised mainly of engineers who might tend to favour hardware solutions. However, the FEDB team should recognise that in many buildings the implementation of a well defined and maintained management system can often provide a much more effective means of reducing the overall fire risk.

Chapter 7 provides data that should be considered when developing trial concept designs. This is not exhaustive but provides a guide both to the types of systems that should be considered and to the basic information required to enable a quantified study to be carried out. These data are also used when it comes to detailed building characterisation for the purpose of analysis.

Chapter 5 provides more information on concept design options which may be utilised for the various sub-systems, when trial concept designs are being developed.

### **4.7 Methods of evaluation**

Having established one or more trial concept designs and the significant fire scenarios, the FEDB team should provide guidance on the depth and scope of quantification required. Indeed, the FEDB study may eliminate further detailed analysis if, for instance, qualitative study has clearly shown a level of safety which is equal to, or better than, that in prescriptive codes and guidance documents.

To establish the required scope of quantification, the FEDB team should agree the extent to which each fire scenario requires quantification. Where possible, agreement should be reached on the type and complexity of analysis required to provide an adequate solution. For instance, when considering smoke movement, simple hand calculations may be appropriate in relation to one fire scenario whereas a more complex, computer based model may be more appropriate to another.

The type of analysis procedures that the FEDB team may consider include:

- (a) simple calculations;
- (b) a computer-based time dependent analysis;
- (c) a full probabilistic study, ie. comparative PRA; (Level 3)

In some circumstances where a quantitative analysis is not appropriate, detailed qualitative study or full scale fire testing may provide an effective means of arriving at a design solution. Such options will be possible under the new Performance based BCA.

## **Chapter 4 - Fire Engineering Design Brief**

A time dependent study (Level 2), using comparative criteria will generally require far fewer data and resources than a probabilistic approach and is likely to be the simplest method of achieving an acceptable design. A full probabilistic study (Level 3) is only likely to be justified when a substantially new approach to building design or fire protection practice is being proposed or where less conservative design for a large or complex building may result in significant construction savings.

### **4.8 Design Documentation and Reporting**

It is relatively straightforward to establish whether various provisions have been appropriately implemented when checking that a trial concept design complies with traditional building regulations and design guidance documents. This “Fire Engineering Guidelines” document, however, encourages a flexible approach to design, using performance-related requirements rather than prescriptive solutions. It is, therefore, not possible for an approvals body simply to compare the proposed design against a set of well-defined recommendations. Because of this, the results of a fire engineering study ought to be fully documented in a way that can be readily assessed by the building surveyor or other third party. The report should set out clearly the basis of the concept design, the calculation procedures used and any assumptions made during the study.

The format of the report will depend on the nature and scope of the fire engineering study and analysis, but it should typically contain the following information:

- (a) objectives of the study;
- (b) description of the building and its type of occupancy
- (c) results of the FEDB:
  - (i) membership of the FEDB team;
  - (ii) fire safety objectives;
  - (iii) results of the hazard identification;
  - (iv) basis for selecting fire scenarios for analysis;
  - (v) acceptance criteria;
  - (vi) trial concept designs;
  - (vii) redundancies between and within sub-systems.
  - (viii) influence of fire-safety management;
- (d) analysis of results:
  - (i) assumptions;
  - (ii) engineering judgements;
  - (iii) calculation procedures;
  - (iv) validation of methodologies;

## **Chapter 4 - Fire Engineering Design Brief**

- (v) sensitivity analysis;
- (vi) evaluation of results of analysis against acceptance criteria;
- (e) identification of final concept design
  - (i) fire protection measures to be provided
  - (ii) 'management in use' issues integral to the design.
- (f) references:
  - (i) drawings;
  - (ii) design documentation;
  - (iii) technical literature.

It is recommended that reporting be undertaken in 2 stages, to reflect the design process outlined in these guidelines. When the FEDB stage has been completed, it is recommended that parts (a), (b) and (c) of the report should be completed. This first stage report should then be checked and agreed by all parties involved in the FEDB, to assist the fire engineer in the analysis and evaluation of the trial concept design(s).

Once the analysis and evaluation is completed, the fire engineer should complete a comprehensive report including all sections (a) to (f).

It is critical in the Final Report of the fire safety concept design that all fire protection equipment and materials proposed for the building's fire safety system be carefully identified. It is equally critical that all 'management in use' issues, upon which the concept design is based are also well defined. These management issues may include particular methods of installation and construction, operation of the building systems (including control of combustibles and evacuation drills), and specific testing and maintenance regimes, considered necessary to ensure equipment or material performance. Whilst regulatory administrative provisions relating to such 'management in use' issues of performance based designs are still being developed in Australia, it is important that any relevant issues be highlighted in concept design reports and even more important that they be faithfully implemented during the building construction and operation phases of a project.

### **4.9 Detailed Design and Documentation**

Once the concept design is approved, the detailed design and documentation can be undertaken. These guidelines do not cover this phase of the design process. It is however incumbent upon the design team to ensure the detailed design specifications, construction and final certification reflect the agreed concept design and that the completed construction fully achieves the design objectives and acceptance criteria.

#### **References**

Purser, D.A., "Toxicity Assessment of Combustion Products", SFPE Handbook, Section 1, Chapter 14, 1988

### **CHAPTER 5**

#### **DESIGN GUIDANCE**

- 5.1 Introduction
- 5.2 Planning and Design Considerations
- 5.3 Fire Initiation and Development Design Considerations
- 5.4 Smoke Management Design Considerations
- 5.5 Fire Management
- 5.6 Detection and Suppression
- 5.7 Occupant Avoidance
- 5.8 Fire Brigade

#### **5.1 Introduction**

In reality, absolute protection of life and property from fire in the built environment is unattainable and, even if attainable, prohibitively expensive. However, too little expenditure on fire safety could result in levels of life loss that would be unacceptable to the community. Between these extremes will exist a set of cost-effective solutions, in which it is feasible to minimise the total cost associated with fire, consistent with achieving levels of life safety which are acceptable to the community.

The severe consequences of fire in buildings have caused communities to control the design and use of buildings through laws and regulations. The good fire safety record which has been achieved in Australia may be attributed, in part, to current building regulations. However, these regulations are both prescriptive and restrictive in their application. Further, the evolutionary nature of development of these regulations has resulted in limited application of fire engineering technology; possibly in excessive conservatism and in indications that such codes are not optimal in the interests of the society they serve. Concern has been expressed that possibly excessive costs are incurred in maintaining Australia's fire safety record, highlighting the need for identification of cost-effective design solutions.

It has long been recognised that in order to realistically manage the effects of various hazards, including the effects of fire in buildings, it is inappropriate to rely solely on a single component or sub-system to manage such hazard. For example, it is well recognised that fire safety and protection components and sub-systems do not work perfectly, and that there is always a finite chance of failure of such components and sub-systems, particularly when subjected to fire conditions.

To recognise actual fire conditions and to ensure adequate hazard management, authorities and the community require, by regulation, that a level of redundancy be incorporated into designs. However, it is the very issue of prescribing redundancy which gives rise to concern about excessive costs. There are widely held views in Australia that the current building regulations provide very adequate levels of fire safety but prescribe excessive levels of redundancy in either the number or the extent of components or sub-systems required.

Consider for example, a simple situation of two alternative fire safety design strategies in which the first design relies solely on a passive fire protection sub-system and the second relies on both a sprinkler sub-system and a passive fire protection sub-system. Clearly to maintain a consistent level of life safety, the level of passive fire protection in the second strategy should be less than that of the first.

Evaluations based on consideration of separate fire scenarios can be used to quantify the performance of a passive sub-system and the performance of a sprinkler sub-system when each is operating in isolation, but such separate fire scenario evaluations cannot be used to identify appropriate, cost-effective combinations of active and passive protection. The second strategy referred to above is indicative of redundancy prescription in building codes and is typical of the issues that fire safety engineering, based on risk assessment techniques, is ideally suited to resolve.

Pressures have arisen in Australia for the introduction of a performance-based approach, enabling more flexible and rational engineering methods (incorporating risk assessment methodologies) to be used to identify cost-effective fire safety solutions for overall building designs (total building fire safety systems). In response, systematic methods have been developed for rational design of fire safety and property protection systems for buildings. Over a number of years, research has been undertaken into the development of risk-cost assessment models for estimation of both “risks to life safety” and “the economic consequences of fire” in buildings. In these activities, emphasis has been given to techniques that can be used for performance assessment of the fire-safety system and for identification of cost effective designs.

Assessments based on consideration of the outcomes of separate fire scenarios provide a satisfactory approach to the design of individual fire safety sub-systems but such assessments do not provide a satisfactory framework in which to combine different sub-systems and hence identify cost-effective fire safety system design solutions.

## **5.2 Planning and Design Considerations**

### **5.2.1 The Building Project Process**

A building may be procured in a number of ways. One way is to physically design the facility in accordance with a brief, developed from assessment of client and occupant’s (end users) needs, and subsequently construct it in accordance with the design. This sequence of activities can be defined in the following stages :

- Feasibility
- Conceptual design
- Design development
- Design documentation
- Construction
- Commission and handover

These guidelines concentrate on the feasibility and concept stage and initial design activities - to the point where plans are produced that are of sufficient detail for the preparation of a preliminary estimate by a quantity surveyor.

It is generally accepted that once the concept or sketch plans have been signed off by the client, 75% of the overall cost has been committed and any further effort will only affect the remaining 25% of project cost. It is equally well recognised that decisions made during the early stages of a project will have maximum impact on cost savings.

During development of a building's conceptual design, one sub-process involves preparation and agreement of a series of sketch plans illustrating how the total "spaces" within the building will be "massed" or arranged. The outcome is a building footprint and a series of internally related layouts. This basically involves the "planning" of the building and involves:

- a. Development of the footprint of the building by allocation, massing and arrangement of space and functions, that once assembled comprise the entire building envelope.
- b. Development of the internal layout in a formal sense.
- c. Development of the circulation network and the degree of building legibility.
- d. Development of a detailed building envelope.

The success or otherwise of this planning can be assessed against the client's brief. If the layout is functional, the inter-relationships will be satisfactory between the spaces, people, processes and activities, etc. that the building is required to accommodate.

This process also has implications for cost effective design of the building's fire safety system, the main objectives of which may not change but the ease by which they can be satisfied will be a direct function of the building's planning.

### **5.2.2 Planning of Occupants**

The building fire safety sub-systems mostly affected by building planning are:

- a. Occupant Avoidance (SS5)
- b. Fire Spread (SS3)
- c. Smoke Spread (SS2)
- d. Detection and Suppression (SS4)

There are two types of generic plan, "closed" and "open". The degree of planning may be formal or "free" or somewhere in-between, dependent upon the type of occupancy. Residential and health care buildings are normally more formally planned than retail, industrial and office type occupancies. Open planning is synonymous with large retail and industrial complexes.

Mazes or labyrinths are more common in closed planning and are often the egress system, especially for spaces accommodating large numbers of people centrally within the building and in upper storeys. Access to exit systems and location of the exits in relation to their height and point of discharge of each exit can be extremely complex and egress can often dictate the plan shape/footprint of a building.

Travel distance, a measure of "access to exits", often dictates the location of stairs and may even dictate the building's physical orientation on site. This can apply to buildings with relatively small populations and/or occupant loadings (ie.: persons per square metre of floor area).

Planning is therefore seen as an activity that can significantly affect the development of a cost effective design and issues which can influence the occupant avoidance sub-system include:

- i. Occupant loading
- ii. Zoning of the building by use/organisation etc. as this will also influence the evacuation requirements.



- iii. Allocation of exits according to those zones.
- iv. Allocation of circulation space to compliment (iii) and still permit the degree of security, privacy, tenancy, and required subdivision of building functions.
- v. Allocation of other circulation spaces for normal and emergency requirements.
- vi. Barriers that may restrict the movement of occupants during emergencies.

### **5.2.3 Planning and Fire Scenario**

The degree of open versus closed planning can often define the manner in which a fire can grow and spread from the enclosure of fire origin. Corridors, open stairs, spandrels, shafts, etc. can often provide paths along and through which fire is able to spread. Spaces which are more open than others may act as an initial reservoir for smoke, providing valuable additional time for occupants to evacuate.

For example, a corridor can link one room to two stairs. These stairs may be the only two exits from a storey. The two stairs are meant to act as alternative exits. If a fire were to break out in the room and the door was left open, the corridor would soon be filled with smoke and access to the two stairs denied. Occupants in the other rooms linking to that corridor may still be unaware of the fire and their only escape route, the corridor, would be unavailable.

Planning can therefore provide opportunities. Closed plans provide opportunities for compartmentation (confinement of smoke and fire spread by passive means). Open planning generally provides opportunities for systems based on smoke management via active means (sprinklers and mechanical smoke management).

Smoke and fire spread implications can be assessed qualitatively at this stage. Subject to other constraints, a building can be planned to provide maximum opportunity for the development of alternative solutions, allowing the structure and building fabric to be utilised as part of the sub-systems. The degree to which specialist fire protection systems can be avoided can be viewed as a measure of cost effectiveness.

### **5.2.4 Planning - Detection and Suppression**

The relationship between building planning and this sub-system may not be readily apparent.

Areas of a building which are subdivided in a formal manner may result in increasing likelihood of remote fire. Occupants may require additional time to investigate and establish the state of a fire. Open planning can provide occupants with greater opportunity to physically locate a fire and initiate avoidance action.

The degree of planning also affects the cost effectiveness of detectors and sprinklers - as measured in terms of floor area per device eg. m<sup>2</sup> per detector or sprinkler. The ratio will generally be lower for closed plans and higher for open plans. This relationship may be seen by some as an opportunity in terms of the systems specified. From the fire safety view-point, closed planning in association with sprinklers can be very effective, although there will be a price to pay in terms of cost/m<sup>2</sup> of floor area. However, other trade-offs and savings may be possible to offset the increased sprinkler costs..

### **5.3 Fire Initiation and Development Design Considerations**

As in any engineering design process, fire-safety design hinges on a balance between two fundamental concepts, namely loading (expressed as the characteristic fire profile) and the fire-safety system performance (in coping with the characteristic fire profile). This provides a measurable expression of the objective being pursued. Two aspects of the characteristic fire profile need to be considered in a fire-safety engineering design, namely its effects and its probability of occurrence.

When dealing with the probability of occurrence of a particular characteristic fire, the most relevant aspect is the likelihood of ignition, requiring consideration of:

- Survey information on the location of possible causes of ignition;
- Statistical information on sources of ignition, frequency of occurrence and intensity of fires for the relevant occupancy and building activity, and
- the intended implementation of maintenance and good housekeeping measures.

To deal with the effects of the characteristic fire profile, it is important to identify its constituent components. Control is achieved by controlling these components, in fact, the actual design process aims at influencing, in an appropriate manner, each of the components. These are -

#### **a. Rate of fire growth.**

The rate of fire growth can be influenced by controlling the selection of materials for the building and its contents. The arrangement of contents also plays an essential role on the likely fire growth. Of particular importance is the distance between adjacent combustibles and the height at which they may be stacked. Whilst a wider separation distance can decrease growth rate, higher stack levels increase it.

#### **b. Termination of growth.**

Fire growth can be terminated by design-selected agents, such as automatic suppression. The designer can select a particular type of sprinkler, on the basis of predicted time of operation and the influence it can have on the predicted fire growth. In the absence of automatic suppression, fire growth can be influenced by fire-brigade intervention and, with lesser design predictability, by occupant's manual suppression.

#### **c. Time for flashover.**

Flashover is an undesirable event, which couples untenability remote from the fire origin, very rapid increment in smoke and heat hazard and the beginning of an intense attack on the building structure. For this reason, designers need to predict the likelihood and timing of flashover and seek means to influence these. As flashover is highly dependent on the concentration of heat within the fire enclosure, the most effective influencing measures are related to heat minimisation. Firstly, minimising heat generation at the source (by material control as previously described) and secondly, by maximising heat dissipation through relief or venting.

### **d. Ventilation-controlled burning rate.**

Burning rate can be controlled by limiting the supply of oxygen. There is always a chance that a fire will gain access to additional sources of air, by shattering windows and damaging protective barriers.

### **e. Fuel-limited burning rate.**

The limitation of combustible contents wherever possible, separation by barriers and the action of making the fuel less likely to burn, eg. by use of fire-retardants or by allowing sprinklers to discharge water over the fuel provide effective design-based means of influencing burning rate.

### **f. Decay.**

The period of fire decay may extend for a long time, creating undesirable smoke and heat hazards. In practice it may be necessary to precipitate the decline by use of the suppression methods available, or by effective management.

## **5.4 Smoke management - design considerations.**

Smoke is the main cause of death in fires and, as such, smoke management is of utmost importance in the design of buildings housing large populations. Smoke damage to contents and property may also be a design issue, particularly in large warehouse stores. Design features aimed at control of smoke address one or more of the following aspects of smoke generation and movement:

### **a. Minimising smoke generation at source.**

The amount of smoke generated depends primarily on the size of the fire. Control of fire growth as discussed in Clause 5.3 also assists in reducing smoke quantities.

### **b. Capturing the smoke near the source.**

As hot gases issuing from a fire move upwards to a ceiling and then sideways under it, increasing amounts of clean ambient air are entrained. As a result, the total volume of smoke that fills an enclosure consists almost entirely of the air that was entrained. The temperature and hence buoyancy of the cloud of smoke depends on how far the process is allowed to continue. An undesirable extreme is one ending up with a voluminous cloud of cold (and hence non-buoyant) smoke which is virtually impossible to manage. Design of smoke management systems should therefore aim at capturing the smoke as early as possible. In an atrium shopping centre for example, management of smoke produced by a fire in a speciality shop could require at least five times more volumetric flow of mechanical exhaust if the smoke is captured at top of the atrium, than if it was locally extracted from the shop. A similar relationship would apply with respect to potential damage in that case.

### **c. Isolating smoke within smoke barriers or compartments.**

Barriers can be used to provide smoke management. The barriers can be either designed as part of the smoke management system or fulfil other purposes within the building. In considering smoke barriers at design stage it should be remembered they do not need to be fire-resistant. An effective barrier to the passage of smoke at doorways consists of providing transom baffles and creating an air movement at an appropriate velocity in the direction opposite to smoke movement.

### **d. Keeping smoke away from confined escape routes.**

Barriers can also be used to keep smoke away from escape routes. Where penetrations exist or smoke seals are not provided, fire barriers can be supplemented by a pressurisation system. For example fire stairs are pressurised so that upon opening a door into the escape route, a stream of air will flow out and prevent smoke ingress. The appropriate air velocity depends upon the pressure exerted by the hot smoke being restrained and the need to prevent backlayering.

### **e. Keeping smoke in a hot layer away from the occupants (or contents).**

In large, public, single-compartmented buildings including atria, it is difficult to contain smoke away from the occupants as all floors are inter-connected. Design of the smoke-management system involves prediction of characteristics of the hot layer, especially its temperature and height of interface and designing the system to ensure that the two-layer configuration is stable and that the height of the hot layer is appropriate to prevent immersion of occupied areas.

### **f. Reliability**

Complex, multi storey smoke management systems may involve proper operation of many components for successful performance. Research and anecdotal evidence suggests the greater the complexity, the less the reliability. Use of simpler smoke management systems, where possible, is encouraged along with reliability as an important design consideration.

## **5.5 Fire Management**

### **5.5.1 General**

This section describes in terms of effectiveness and reliability, design considerations which reduce or limit the spread of fire within a fire enclosure and to adjoining enclosures. In general, a fire is best controlled at its early stage, before it becomes fully developed or reaches flashover.

### **5.5.2 Managing Flame Spread Within Combustibles**

Fire retardants are added to a combustible material to delay, reduce or suppress combustion of the material. The retardants interfere with the combustion process by acting physically or chemically in the solid, liquid or gaseous phase of the fire process. Physical retardant mechanisms include forming a protective layer, endothermic cooling, heat sink and dilution using inert gases. Chemical mechanisms include accelerated decomposition to limit the heat source, accelerated char-formation and reduction of pyrolysis rate. A particular retardant may exhibit one or more modes of action and the modes may vary according to the chemical nature of the material being retarded. In general, chemical retardation mechanisms are more effective than physical mechanisms.

Fire retardant materials are generally designed to cope with only a relatively small heat source. They are generally effective in reducing the likelihood of ignition of the material, and if ignited, minimises the likelihood of sustaining combustion. However, if established burning of a fire retarded material occurs the effect of the fire retardants become less significant.

### **5.5.3 Managing Fire Spread to Adjacent Combustibles Within Fire Enclosure**

The likelihood of a fire igniting an adjacent combustible depends upon a number of factors (see Section 8.). Of these, the radiative heat flux on the combustible is of fundamental importance and the likelihood of fire spread can therefore be minimised by reducing radiative heat flux to levels below the critical radiant heat flux for ignition. This may be achieved by the following two means:

#### **a. Reduce radiation from hot layer.**

The imposed radiation on combustibles may be reduced by lowering the radiation contributed by the hot gas layer accumulating beneath the ceiling. This may be achieved by naturally or mechanically venting out the hot gases in the fire enclosure, such that they do not accumulate. The reliability of this approach obviously depends upon the reliability of the mechanical or natural venting system and its effectiveness may be limited depending upon the growth rate of the fire. However, if the fire is in a large enclosure with a high ceiling, then the combined effects of an increased ceiling-floor separation, together with mixing of the hot gases with a large volume of ambient air could sufficiently reduce the imposed radiation level on combustibles. Venting of the gases may not be necessary if the fire burns out before the accumulating gases become very hot.

#### **b. Provide adequate separation.**

Radiation from the fire plume onto a nearby combustible may be reduced by horizontally separating the combustibles, or group of combustibles, by an adequate distance. Adequate separation may also be achieved by use of non-combustible internal walls and partitions, acting as radiator shields. Obviously, these approaches are only valid at the early growth stage when the fire is relatively small. In addition, there must be means to ensure that during the life of the building, the arrangement for separation of combustibles will not be altered without renewed consideration of fire safety design.

Each of the above methods act independently and each can contribute to the likelihood or otherwise of fire spread. The methods must therefore be considered together for effective control of fire spread. Also the effectiveness of these methods can be enhanced by the use of fire retarded materials as discussed in Section 5.5.2.

### **5.5.4 Managing Fire Spread to Adjoining Enclosures**

A fire may spread to adjoining enclosures through planned openings in the boundaries of enclosures or due to the failure of barriers and creation of unplanned openings between enclosures. Managing the closure of openings is therefore important to the control of fire spread. Alternatively, automatic sprinklers offer an effective and reliable means of controlling fire spread by extinguishing the fire itself. These are discussed in the following sections.

#### **5.5.4.1 Fire Spread Through Openings**

Fire spread through an opening to an adjoining enclosure occurs by means of a combination of radiative heat flux through the opening and accumulation of hot gases which escape through the opening and collect beneath the ceiling of the adjoining room. Additionally, fire spread by means of flying brands is likely if the fire grows in intensity and the exchange of flow through the opening becomes more vigorous. Means of controlling fire spread through an opening may be achieved to a certain extent by the methods described in Section 5.5.3. Obviously, the most effective means is to avoid unnecessary openings in the

boundaries of fire enclosures. In addition, reduced ventilation to the fire can significantly delay its development and growth, with the possibility of self-extinguishment. The following are means by which the likelihood of fire spread through openings may be reduced.

### **a. Fire stopping of construction openings.**

Fire stopping materials should comply with the appropriate standards regarding their use and installation (eg. AS4072). The services which penetrate the openings should also be sufficiently restrained to prevent them from “pulling out” the fire stopping material. Because many construction openings tend to be located in concealed spaces, care must be taken to ensure fire-stopping is not over-looked at these places.

### **b. Good fire safety practice to manually close doors in a fire emergency**

Because doors (and windows if applicable) are large openings, they offer an easy and direct means for fire to spread. Educating occupants to display good fire safety practice, by closing doors to fire enclosures, can significantly reduce the likelihood of fire spread, but the reliability of achieving this ideal is obviously difficult to determine.

### **c. Automatic door closers which are activated in a fire emergency**

Another approach to door closure is that in which doors are held open by magnetic catches and are automatically released when a fire alarm is activated or electric power fails (reference should be made to AS1905.1 for details). This system is particularly suitable in occupancies where fire safety education of occupants cannot be realistically achieved (eg.. public buildings). It also overcomes the practice of doors being wedged open to ease pedestrian movements. Care should be taken to assess the effects of common mode failures if the door closers are linked to the detection system.

### **d. Protection of openings in fire resistant barriers**

These are typically fire doors, windows and shutters in fire resistant walls, although smaller sized openings such as vision panels in fire doors are relevant. Generally, these protected openings offer less resistance to fire spread than the barriers in which they are located, unless suitably protected.

### **e. Use of fire resistant glazing.**

Because normal glazing in an opening can fail early in the fire growth stage, it becomes a vent and allows more oxygen to the fire. If the glazing can withstand the growing temperatures for a longer period, as can fire resistant glazing, the fire may be suffocated or sufficiently delayed in development for egress to be completed or for the fire brigade to attend the fire.

#### **5.5.4.2 Fire Spread Through Barriers**

In general, fires are only likely to spread through openings. Hence fire spread through a barrier is only likely to occur when the barrier fails and develops one or more openings.

Barriers which comprise internal walls or partitions are generally not designed to withstand a severe fire, unless they are intended to protect a safe egress path. However, even these barriers have an inherent fire resistance (eg.. acting as radiation shields) and can adequately limit the spread of fire during the early growth stage.

Barriers which are designed to withstand a fully developed fire obviously offer a more effective and reliable means of preventing fire spread. Structural members such as beams, columns and walls which support barriers must of course have fire resistances not less than the barriers.

### **5.5.5 Managing Vertical Fire Spread**

Fire can spread vertically to other enclosures within the building through openings in enclosures or through failure of barriers and hence the considerations discussed in Section 5.5.4 are directly relevant, where applicable. Fire may spread vertically in a building through internal and external routes and these are considered in the following sections.

#### **5.5.5.1 Internal Vertical Spread Routes**

Of particular relevance when considering vertical fire spread via an internal route in a building is the existence of continuous vertical spaces, such as service ducts, shafts and stairways. Construction openings which penetrate all floors are also relevant if not fire stopped. Because these spaces are continuous and often provide access to a large number of connecting enclosures, entry to these spaces must be well sealed and protected. Access to such a space has the potential to enhance the ventilation conditions of the fire.

The hazards of spread to remote enclosures via these routes is usually more directly relevant to smoke spread than fire spread. This is because the cooling and mixing of the hot gases in these spaces usually result in gas temperatures which are less likely to cause ignition of the combustibles exposed to them. Hence enclosures closer to the fire are more at risk to fire spread, although this obviously becomes less true as the fire becomes more intense.

#### **5.5.5.2 External Vertical Spread Route**

Fire may spread to the next floor via flames which project through external openings and radiate back to the windows above. In the Building Code of Australia, if the building is unsprinklered, spandrels are required to be constructed to limit this type of vertical flame spread. Spandrels which project vertically have been shown to be less effective than horizontal projections. The former usually require unrealistically high projections whilst the latter lacks architectural appeal. Calculation of the radiation level on the window above, based on an empirically derived flame shape is available (Drysdale 1988). However, flame projections from windows are highly variable and such calculations should be used with caution.

Automatic sprinklers (see 5.6) are highly effective in controlling fire spread via an external route. Drencher systems are also effective if they are designed to prevent glazing from breaking but may not sufficiently reduce the intensity of the fire.

### **5.5.6 Managing External Spread to Adjacent Buildings**

The issues discussed in Section 5.5.5.2 (Managing Flame Spread Within Combustibles) also apply here. Additional consideration should be given to the contribution of radiation to the adjacent building from a number of sources in the fire floor

### **5.6 Detection and Suppression**

#### **5.6.1 Humans as Detectors**

Humans are still the best detectors of fire, sensing fires at lower concentrations of combustion products than even the most advanced fire detection equipment.

In many applications, therefore, use can be made of building occupants to provide the first line of detection and initiate early fire suppression action. Hospitals are an example where staff are awake and alert at all times and have a reasonable chance of detecting incipient fires.

In other applications, a major difficulty with humans as detectors is their propensity to go to sleep or to use drugs and alcohol that significantly reduce their probability of successful detection. This can apply particularly to security personnel or watchroom staff, who may find it difficult to maintain attention. Aid can be provided for humans by means of supplementary devices, which initiate action and improve detection probability.

With humans as detectors, care must be taken to ensure occupants do not delay alarms or inadvertently shut down smoke control or fire suppression systems.

#### **5.6.2 Smoke Detectors**

Available smoke detectors operate on a number of different principles and over a wide range of sensitivity. The design objective and size of fire required to be detected must be clearly identified in order to choose the most appropriate type and design of smoke detection system.

Smoke detectors used for life safety in a wide range of residential applications are typically point type ionisation or photo-electric (optical) smoke detectors. For flaming type fires, ionisation detectors operate at an earlier time than photo-electric detectors. Conversely, photo-electric detectors operate more quickly during the smouldering phase of fires.

These different operating characteristics of ionisation and photo-electric smoke detectors need to be considered when choosing detectors for protection of property and important contents, such as computers, telephone exchanges and other critical commercial, industrial facilities.

Where point type smoke detectors would take an excessive time to operate, other smoke detector types are available to provide earlier alarm signals. Examples are aspirated, high sensitivity sampling systems for electronic equipment protection and beam type smoke detectors for large warehouses and aircraft hangars.

Smoke detectors are thought to have a lower probability of successful operation than heat detectors, due to their higher sensitivity; their open structure needed to allow smoke entry and more complex design. Also, the prediction method for operating times of smoke detectors is not yet well developed, particularly for high sensitivity devices.

Whilst smoke alarms for residential premises are available at low cost, commercial smoke detectors are generally more costly than heat detectors on a per unit basis. However smoke detectors are often spaced more widely than heat detectors, so that the overall installation cost of detectors, wiring and panel may not be very different.



### **5.6.3 Heat Detectors**

For most fires, except those involving clean burning flammable liquids, heat detectors generally operate at a later time than smoke detectors. They are generally considered to offer general property protection rather than life safety or protection of high value electronic and process equipment.

The prediction of time of operation of heat detectors is reasonably well developed and Australian heat detectors designed to AS1603.1 are available in rate of rise and fixed temperature types. The probability of successful operation is considered to be higher than for smoke detectors but their effectiveness in life safety is less.

### **5.6.4 Flame Detectors**

Flame detectors give a very rapid response to fires which have significant flame, such as those involving flammable liquids.

A choice exists between infra-red (IR) and ultraviolet (UV) flame detectors. They respond to a threshold level of electromagnetic flame radiation in the appropriate wavelength range. Consequently they need essentially a line of sight between the fire flame and the detector. Smoky fires, shielded fires and dirty detector optics can all render flame detectors inoperative.

Typical applications for flame detectors are aircraft hangars, flammable liquids stores, offshore oil rigs and particular industrial processes where very rapid detection is required (often micro-seconds) and where linkage to rapid fire extinguishment or explosion suppression is a design requirement.

The reliability of flame detectors has traditionally been poor with many false alarms and low success in detection. More recently developed flame detectors have increased the power of discrimination between flame and non-fire radiation sources. This has reduced false alarms and improved the probability of success. However, regular cleaning, checking the detector's cone of vision and extensive maintenance is required to ensure high probability of success.

Due to low production runs, complexity of design, and construction to withstand harsh environments, flame detectors are generally higher in cost than other detector types on a per unit basis. However, particularly in large open spaces, such as aircraft hangars, long range IR flame detectors may be quite cost effective.

### **5.6.5 Portable Extinguishers**

The use of portable extinguishers by building occupants for extinguishing fires often provides the earliest form of (and time to) fire suppression when the fire size is small.

Portable extinguishers use agents including water, foam, dry chemical and gaseous substances. Choice of extinguisher depends on the type of fire expected.

Effective use of extinguishers depends on the extinguishers being properly located, well maintained and operated by trained occupants. It is critical, of course, for manual suppression that occupants are available to use the extinguishers. That being the case, the probability of success of portable extinguishers is reasonably high, although many occupants will have other higher priority objectives, such as warning, rescue, salvage and escape.

Portable extinguishers are manufactured to appropriate Australian standards and are generally of low cost and reliable if properly maintained.

### **5.6.6 Automatic Sprinklers**

For many applications, particularly where there are no occupants available to detect fires or trained to use portable extinguishers, an automatic suppression system is required.

Sprinklers provide an excellent option in a wide range of applications and are considered to overcome many deficiencies in building construction. These systems provide the detection, alarm signal and suppression action and have a high degree of reliability due to their simplicity.

There are a wide range of sprinkler design options, depending on the occupancy. For life safety applications, residential or fast response sprinkler heads (low response time index - RTI) operate at quicker time than do conventional sprinkler systems.

For industrial applications such as warehouses and high rack storage, higher water densities and early actuation is required to ensure water is delivered to fuel surfaces through highly buoyant fire plumes. For these higher challenge fires, the probability of success has to be less than the 99% plus claimed generally for sprinkler systems. However, recent developments in ESFR and large drop sprinkler technology have provided more cost-effective options that are suited to those high challenge situations and offer flexibility in use.

The prediction of time of operation of sprinklers is reasonably well developed but the time for suppression to be complete is less well known. Reliance is still placed on conventional design codes such as AS2118.1 and NFPA13 for detailed design of sprinkler systems.

For residential occupancies there are new Australian Standards based on NFPA13D for domestic premises, AS2118.5 and NFPA13R for residential buildings such as hostels, nursing homes and smaller hotels. These systems are of lower cost than traditional AS2118 designs, particularly AS2118.4 through use of new plastic, copper or light wall piping systems and reduced water supply/piping requirements.

### **5.6.7 Gaseous Suppression Systems**

For protection of critical electronic, process and other equipment, and suppression of flammable liquid fires, gaseous systems are often used to extinguish fires at an earlier time and smaller size than is possible with sprinklers. There is also not the water damage associated with sprinkler systems and this is critical in some facilities.

Gaseous systems are usually actuated by fire detectors, after smoke detection. Due to the complexity of these systems, the probability of successful operation has traditionally been low and their cost high. Use has therefore been limited to high value, high consequence areas where a small fire could lead to severe property damage or high loss business interruption.

### **5.7 Occupant Avoidance**

#### **5.7.1 General**

Two of the major design objectives for the effects of fire in a building are to achieve satisfactory levels of life safety for occupants of the building of fire origin and occupants of adjoining buildings. In this context the occupant avoidance strategy must aim to facilitate, support, enhance and manage the actions of occupants in their attempts to cope with and/or avoid untenable conditions from a fire.

#### **5.7.2 Design Strategies**

Prior to any occupant avoidance sub-system design and development, a strategy which meets all the requirements of the particular building under consideration must be adopted. The strategy should incorporate the findings of the latest general and/or specific human emergency evacuation behaviour studies. It is essential that a decision be made at this point whether or not an amplified or detailed design approach is to be used. The latter will usually involve extensive field studies and /or role play.

Strategies related to evacuation and egress can be listed, as follows:

- a. complete, partial or non-evacuation of the building;
- b. provision of:
  - alternative evacuation routes reserved only for emergency situations,
  - regular circulation paths as evacuation routes, or
  - hybrid evacuation routes (alternative routes together with regular circulation paths);

Research clearly shows that the level of detail, as well as the quality and structure of information provided to building occupants play a very important role in evacuation patterns and times. Another aspect having strong impact on occupant avoidance efficiency relates to occupant warning systems. Research also shows other building activities (eg.. security) can infringe on "coping". Coping, which includes fire fighting, has to be examined in detail and optimised, as all activities absorb valuable time. Accordingly, design of a high quality, effective information system that will reduce response time (eg.. voice system vs bells) becomes important. Occupant training in fire fighting is a further aspect. (See Chapter 11).

Once a main strategy is adopted, the designer will need to consider all individual parameters relevant for that particular strategy.

#### **5.7.3 Incorporating Occupant Behaviour and Characteristics into Design**

At present, building codes in many countries assume occupants are fully mobile, non thinking objects which on hearing an alarm or seeing a fire immediately drop everything and proceed directly towards their nearest exit. In reality, occupants have characteristics which will determine the manner in which they will respond to a fire alarm or cue, interact with others and, where applicable, the fire-related environment. Their pre-fire activity is another important factor which will determine whether or not they are able to, or even want to, respond, eg..:

- a. asleep or awake?,
- b. engrossed or focused on an activity, such as concluding a purchase,

- c. background noise is such that the occupants cannot hear the alarm.

There are many factors that affect the capability of individuals to respond, cope and evacuate during a fire emergency. Designers need to be aware of the occupant capabilities in order to achieve an appropriate fire safety system design.

A proper approach to occupant avoidance management is one which will rely on the integration of some or all of the following:

- a. the future building emergency control organisation, plan and procedures and hence the emergency “preparedness” of the occupants
- b. detection and communication hardware
- c. remainder of the building fire safety system in terms of maintenance of tenable conditions in predetermined areas of the building
- d. fire attack and rescue strategy of the local fire brigade
- e. the manner in which the building is zoned.

Occupants who are familiar with the building layout, occupant avoidance sub-system and the nature of fire will be those who have been trained, had past experience and who are highly motivated. These occupants will have a high level of emergency preparedness. The resultant time required for egress would be less than otherwise. A designer could design and put in place an occupant avoidance process that would accomplish savings in the other sub-systems designed to extend the time taken to reach untenable conditions. This process would require ongoing commitment from the occupants and annual certification via audit by the local Council or Fire Brigade.

This approach ie.. fully utilising the occupants, would permit the use of any number of evacuation strategies such as:

- a. Non-evacuation (defend in place)
- b. Sequential evacuation
- c. Partial evacuation
- d. Complete uncontrolled evacuation

Under appropriate conditions, non-evacuation can also be used in those buildings where only some occupants (eg. permanent staff) have been trained.

Each of these strategies can be adopted to:

- i. achieve a greater degree of cost effectiveness in design of occupant avoidance systems eg.. fewer but higher quality exits.
- ii. cater for occupant safety and security needs eg.. prisons, health care institutions.
- iii. facilities with large numbers of people to optimise design of other sub-systems eg.. smoke control associated with safety.
- iv. establish the basis of the building fire safety system eg.. compartmentation/partial evacuation.

Where strategies do incorporate (a) to (e) - and are used to extend egress times and minimise exit widths or other such combinations, the evacuation plans and procedures must be managed in place for the life of the building.

Strategies which incorporate (a) to (e) can result in highly trained and aware building occupants who can evacuate the building at a faster rate, because of their increased capabilities in response, coping and egress. This is a valid approach to design. Such plans and procedures must still be managed in place and be audited each year.

Whatever approach is used, it must be fully documented, followed through, commissioned and managed in place.

### **5.7.4 Concept Plan**

As part of the trial concept design, a concept plan for egress must be developed based on the design brief and the "Client Needs Statement" to ensure specification of the following occupant sub-system components:

- occupant characterisation parameters for classification of occupant groups, definition of occupant profiles and establishment of occupant capability ratings;
- height and pattern of vertical elements (including potential exit systems) and juxtapositions of zones (especially in terms of access control);
- location of exits on plan and emergency circulation routes with preliminary allowances for exit choice, access and carrying capacity;
- area of occupied zones so that the population sizes can be established from occupant loading rates;
- definition of "building legibility" for the purposes of wayfinding and signposting strategy and also in terms of degree of obstruction relating to open versus closed planning;
- information type and design to be provided by fire alarm equipment;
- building use and occupant activity analysis to establish appropriate fire scenarios.
- occupant avoidance management plan/procedures (see 5.7.4).

The concept plan shall include a written statement of initial allowances for evacuation plans and procedures, level of training for occupants, degree of evacuation assistance required, staffing, together with an outline of how the plan and procedures will be managed, maintained and audited in place. There should also be a review of security requirements, as there are certain building occupancies where these requirements can increase the number of coping activities.

A decision needs to be made at this point as to whether the design will be based on default tables or not. To be effective, the designer should consult the research. Field tests or role play are other options but a scientific approach must be used to ensure reliability.

### 5.8 Fire Brigade

#### 5.8.1 General

Suppression of a fire by the fire brigade relies on two factors: communication and response.

Communication may encompass automatic fire detection and signalling to the brigade or rely upon occupant detection and non-automatic brigade signalling via telephone or by other means.

Between communication and extinguishment, a fire brigade goes through the following response stages and from these, only the last four are directly related to sub-system design:

- a. dispatch,
- b. departure from fire station,
- c. travel and arrival,
- d. investigation,
- e. set-up,
- f. rescue, and
- g. extinguishment.

The highest priority in fire brigade operations is saving of life. This is followed by saving of property. Fire brigades operate with three main aims which must form the basis of any design strategy:

- extinguishment of the fire in the building of fire origin,
- preventing the fire from spreading to other adjoining buildings, and
- preventing the fire from reaching untenable conditions in any enclosure to allow effective rescue from that enclosure.

The factors which must be taken into account in determining the expected extinguishment performance are:

**Arrival Time:** pre-planning, staffing type, staff training, station location, appliances type, quality of call, appliance availability and road traffic conditions.

**Set-up Time:** pre-planning, staffing type, fire fighter and equipment access to building, fire fighter and equipment movement within building, availability of reliable information and fire service equipment, provision of protected zones such as firefighting shafts and lifts, smoke control provisions, height of building and building footprint.

**Extinguishment Performance:** fire fighter training, staffing levels on fireground, fire appliances, brigade communications, water supplies, compartmentation and closeness to flashover.

For building design, the fire engineer must assess the likely fire brigade performance, including capability and time to start extinguishment.

If there is a high probability of flashover and major fire spread before brigade arrival and lives and property are at risk, then greater reliance on occupant manual suppression and automatic extinguishing systems will be required. This applies particularly for buildings remote from major cities and country towns where brigade arrival may be delayed. This can have major cost implications for the building.

Where reliance on the fire brigade as the primary rescue and fire fighting component in the building is very high, the fire engineer must ensure that the

## **Chapter 5 - Design Guidance**

communication/alarm and water supply systems are adequate to achieve the desired performance.

The expected performance of the fire brigade in any particular building design should be discussed with the fire brigade, particularly in respect to issues such as access, hydrant location, water supply and capability.

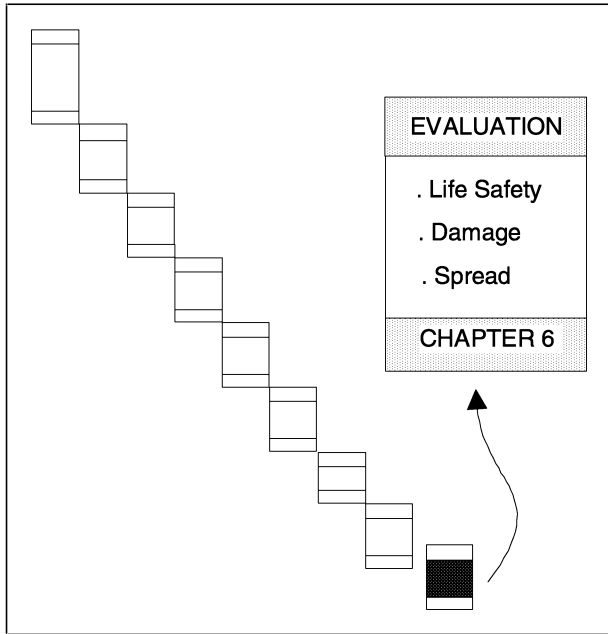

<b>CHAPTER 6</b>	
<b>METHODS OF EVALUATION</b>	
6.1	Fire Safety System
6.2	Approaches to Evaluation
6.3	Criteria for Evaluation
6.4	Different Levels of Evaluation
6.5	Fire Scenarios
6.6	Principles of Evaluation
6.7	Sub-system Equivalence Evaluation (SEE): Level 1
6.8	System Performance Evaluation (SPE): Level 2
6.9	System Risk Evaluation (SRE): Level 3
6.10	Final Reporting

**6.1 Fire Safety System**

The level of fire safety in a building is a reflection of a complex interaction between many phenomena, including: fire initiation, fire growth and spread, the response of building components to fire, the response of occupants to the presence of fire, and the response of the fire brigade to the fire. To achieve required levels of safety from the effects of fire in buildings, then it is essential that designers have at their disposal the means to predict the level of life safety for any particular building design and use. Development of this capability requires a model to quantify the performance of building fire safety systems, as shown in Figure 6.1.

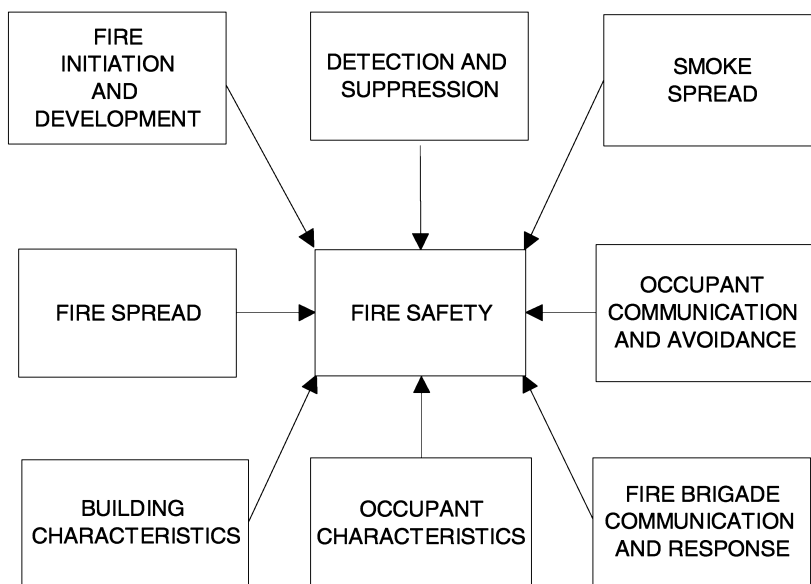

**Figure 6.1 System Performance Model**



### **6.1.1 Fire Safety Sub-systems**

Experience has shown that design of a complete fire safety system for a building is best undertaken by breaking the design and quantification into 6 sub-systems. As indicated previously, these sub-systems are:

- Fire Initiation and Development (SS1)
- Smoke Development and Management (SS2)
- Fire Spread and Management (SS3)
- Detection and Suppression (SS4)
- Occupant Avoidance (SS5)
- Fire Brigade Communication and Response (SS6)

Also relevant are the Building and Occupant Characteristics (as represented in Figure 6.1).

Within each sub-system there are a number of optional fire safety elements from which a selection can be made. For example, in the detection and suppression sub-system we can rely on occupant (manual) suppression by hose reel or portable extinguishers, automatic sprinklers or the fire brigade or some combination of all of these.

The initial choice of a Trial Concept Design (which may consist of single or multiple sub-systems, depending on the Level of Evaluation being undertaken) can be made on the basis of the following considerations:

- effectiveness
- reliability
- cost

Other factors may be utility and how the fire safety measures fits with the day to day operation of the building.

### **6.2 Approaches to Evaluation**

Methods of evaluation for the assessment of the performance during fire of building components, sub-system(s) or the complete fire safety system are based on the use of quantitative fire scenarios.

The method of evaluation can be selected from one of the following three options:

- Level 1: Sub-system Equivalence Evaluation (SEE)  
Comparative Performance of a Component/Sub-system: Single/Multiple Fire Scenarios
- Level 2: System Performance Evaluation (SPE)  
Single/Multiple Fire Scenario(s) Considered in Isolation (Not Combined)
- Level 3: System Risk Evaluation (SRE)  
Multiple Fire Scenarios combined Using a Risk Methodology

The number and type of fire scenarios selected shall be consistent with the method of evaluation undertaken.

These three methods of evaluation are described in greater detail subsequently.

### **6.3 Criteria for Evaluation**

The general principle to be adopted is to evaluate whether the selected Trial Concept Design meets the acceptance criteria specified at the FEDB. The criteria may include both technical and cost considerations. For costs, it is desirable to optimise the overall costs associated with fire, including both the initial costs of construction, maintenance and inspection costs associated with the Trial Concept Design as well as the costs of damage and interruption caused by fire.

This costing exercise can be done for all methods of evaluation; at Level 1 (SEE) only costs associated with alternative fire safety sub-system elements need to be considered, whilst at Level 3 (SRE) the total life-cycle costs associated with the fire safety system can be optimised by use of a fire-cost expectation parameter. This will lead to the identification of cost-effective design solutions.

### **6.4 Different Levels of Evaluation**

#### **6.4.1 General**

A schematic representation of the methods of evaluation (which is based on three levels) is shown in Figure 6.2.

#### **6.4.2 Sub-system Equivalence Evaluation / SEE(Level 1)**

This is the simplest level of evaluation and is intended to establish equivalence between essentially equal performing elements of the fire safety system. This is generally established by comparing the performance (usually specified in terms of the time of occurrence of certain key events) of an alternative Trial Concept Design with the performance of a deemed-to-satisfy strategy as specified in the regulations. It is not appropriate where there is "trade-off" between one fire safety system element and another (such as sprinklers instead of compartmentation). It is also not appropriate when the adequacy of a different level of performance needs to be demonstrated.

The most common application is to demonstrate the equivalent of two smoke control sub-systems, both intended to satisfy the same performance objective. Another common application is to demonstrate the equivalence of a fire detection sub-system with that required in the regulations.

#### **6.4.3 System Performance Evaluation / SPE(Level 2)**

This middle level evaluation methodology is intended to establish equivalence between essentially different sub-systems of the fire safety system. This is generally established by comparing the performance (usually specified in terms of the level of occupant safety) of an alternative Trial Concept Design with the performance of a deemed-to-satisfy strategy as specified in the regulations. It is appropriate where an alternative Trial Concept Design is composed of essentially different elements from those which are contained within the deemed-to-satisfy strategy as specified in the regulations. It is also appropriate when the adequacy of a different level of performance needs to be demonstrated. A common application of this level of evaluation is when assessing the performance of different of detection, smoke control and distance of travel combinations.

Performance is quantified in terms of the safety of occupants. Further, performance is assessed by considering each fire scenario in isolation. In addition, it is possible to separately consider different combinations of fire safety sub-systems (by considering each fire scenario in isolation). It is also feasible to consider separately the effects of a particular sub-system when it is either working or it has failed. Whilst multiple sub-

systems and multiple fire scenarios can be considered using this level of evaluation, the various combinations and scenarios are considered in isolation. Using this non-probabilistic Level of Evaluation, it is not possible to combine the results of each separate evaluation into a combined performance parameter for the various sub-systems being considered.

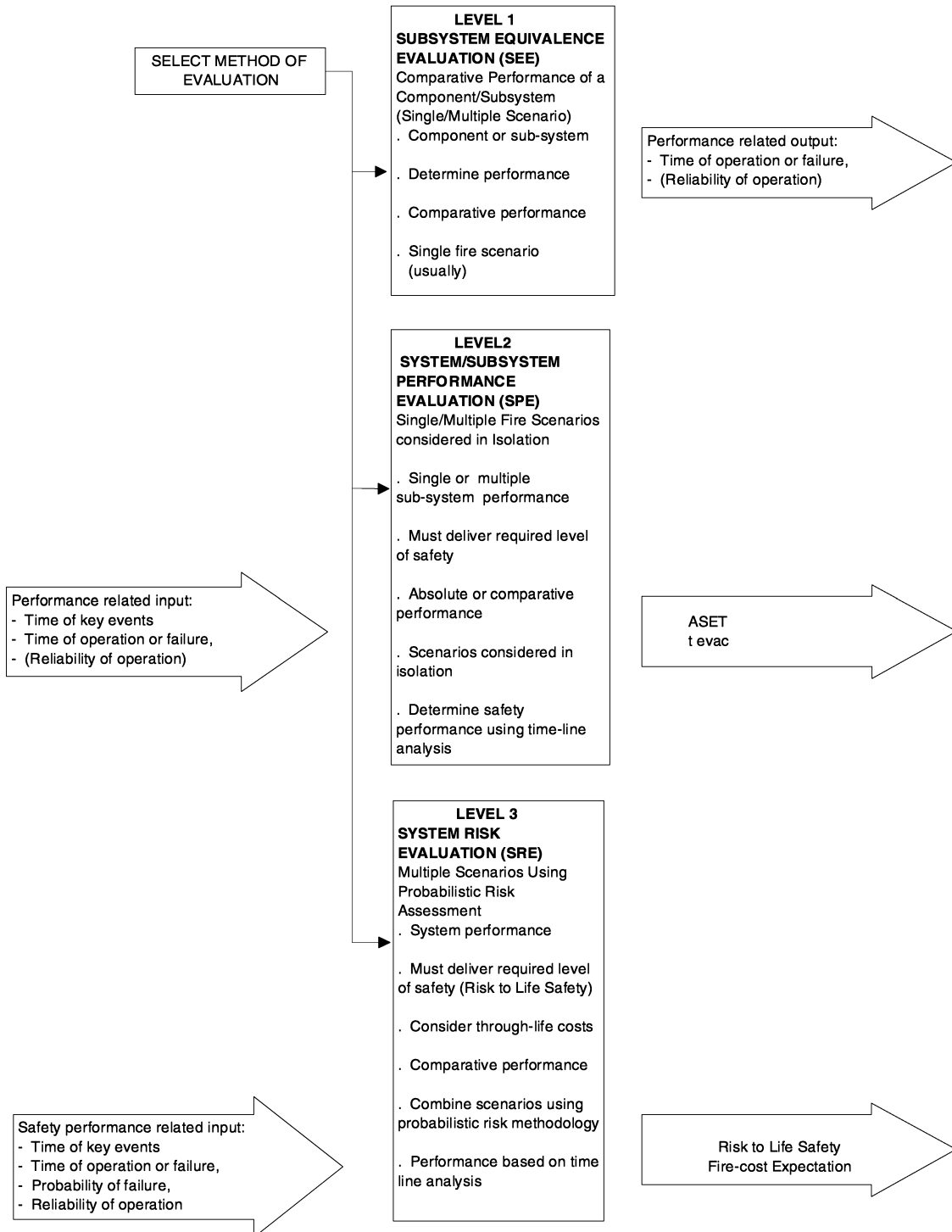

**Figure 6.2 Methods of Evaluation flow chart**

### **6.4.4 System Risk Evaluation / SRE (Level 3)**

#### **6.4.4.1 General**

This is the highest level of evaluation and is intended to establish equivalence between essentially different fire safety systems. This is generally established by comparing the performance (usually specified in terms of risk to life safety and life-cycle fire costs) of an alternative fire safety system Trial Concept Design against the performance of a deemed-to-satisfy system design as specified in the regulations. It is an appropriate method for use where an alternative Trial Concept Design is composed of essentially different elements from those which are contained within the deemed-to-satisfy strategy as specified in the regulations. This level is suited to more innovative designs and/or radical departures from the current acceptable prescriptive regulations.

The performance is assessed by considering initially the performance of different combinations of fire safety sub-systems and fire scenarios in isolation; this is effectively the same as adopted for a Level 2 evaluation. However, the results from each of these scenarios are then combined on the basis of the probability of occurrence of each of these scenarios via the use of an event tree approach. The results of each separate evaluation are combined using a risk assessment framework to yield system performance parameters.

#### **6.4.4.2 Risk assessment framework.**

A Level 3 evaluation requires use of a risk-cost assessment technique in order to combine the various fire scenarios. Risk assessment concepts are explained in Appendix 6A.

#### **6.4.4.3 Cost-effective evaluation criteria**

When designing building fire safety systems, it is appropriate that explicit consideration be given to the level of life safety afforded to occupants of buildings, and to the costs associated with such provision. Such an approach enables designers to undertake a performance-based approach to design, and select the most appropriate cost-effective solution for the building fire safety system.

For a particular building design using a Level 3 Evaluation procedure, the effect of fire can be predicted using two performance parameters, namely, the:

- a) expected risk-to-life, and
- b) fire-cost expectation.

No attempt is made to assign monetary value to either the loss of life or the value of lives saved. This avoids serious moral, ethical and economic difficulties which arise when attempting to assign monetary value to human life or suffering.

To identify Trial Concept Designs which are considered at least equivalent to, and possibly more cost-effective than, designs conforming with current regulatory provisions, the decision criterion is:

"For a Trial Concept Design to be considered acceptable, the expected risk-to-life value shall be equal to or less than the risk-to-life value of a building conforming with the regulations, and the fire-cost expectation for the alternative design shall be less than or equal to the value for the conforming building".

With such a comparative approach it is not required to directly compare estimated risk-to-life values, derived from a risk assessment model, with an acceptable level of risk derived from independent sources. This comparative approach also provides some flexibility in the required level of accuracy for the two performance parameters.

The calculated expected risk-to-life values for designs conforming with current regulatory requirements provide an estimate of current levels of risk to life safety. Under the decision criterion outlined above, these risk levels are used to provide a benchmark for the purposes of identifying suitable Trial Concept Design solutions. Furthermore, the current regulatory designs are assumed to provide a level of safety which may be considered broadly acceptable to the community.

### **6.5 Fire Scenarios**

#### **6.5.1 Fire scenarios - the basis for analysis and design evaluation**

Each level of evaluation is predicated on identifying appropriate fire scenarios for analysis, quantifying these scenarios in terms of the time of occurrence of key events and assessing the performance of the component, sub-system or system under each of the fire scenarios.

The number of possible fire scenarios in a complex building can become very large and often there are neither the data nor the resources available to attempt to quantify them all. The detailed analysis and quantification should therefore be limited to the most significant fire scenarios; this may include a range of different fire types including smouldering fires.

The characterisation of a fire scenario for analysis purposes should involve a description of such things as the initiation, growth and extinction of fire together with the likely smoke and fire spread routes under defined conditions or events. This may include consideration of such conditions as different combinations of outcomes or events (including success or failure) of each of the fire safety sub-systems, different internal ventilation conditions and different external environmental conditions. The possible consequences of each fire scenario should also be considered.

The Fire Engineering Design Brief (Chapter 4) should establish the important fire scenarios and those that can be neglected (eg. whether a very rare fire with the potential to cause a large loss is more or less important than small fires having a higher probability of occurrence but with the potential to produce a similar loss over time). It is important to remember that fires with slow rates of combustion (that is, smouldering fires) may have the potential to cause a large number of fatalities in certain occupancies (for example, residential buildings).

Where alternative Trial Concept Design options are being compared against a reference case (ie. in a comparative study) the quantification can often be considerably simplified. In such instances it may only be necessary to consider a single fire scenario if this will provide sufficient information to evaluate the relative levels of performance or safety of the Trial Concept Design and the reference case.

#### **6.5.2 Development of fire scenarios**

Each fire scenario is represented by a unique occurrence of events and is the result of a particular set of circumstances associated with the fire safety system. Accordingly, a fire scenario represents a particular combination of outcomes or events associated with each of the following factors:

- Types of fires that are generated upon ignition
- Internal ventilation conditions
- External environmental conditions
- Different combinations of outcomes for each of the fire safety sub-systems.

## Chapter 6 - Methods of Evaluation

The purpose of the qualitative analysis and identification of significant fire scenarios in the FEDB is to identify the important fire development scenarios and describe them in a manner suitable for the quantification process.

It may be convenient to categorise the types of fires that may be generated upon ignition as follows:

- Smouldering fires
- Flaming (non-flashover fires)
- Flashover fires.

Some important factors that will influence the fire development are:

- Size and type of ignition source
- Distribution and type of fuel
- Fire load density

Some important factors that will influence the internal ventilation conditions include:

- Door to enclosure of fire origin: open or closed
- Stair doors on the level of fire origin: open or closed
- Building air handling
- Windows to the enclosure of fire origin: open or closed.

Some important factors that will influence the external environmental conditions include:

- Summer conditions
- Winter conditions.

A fire scenario can also be defined by specifying a particular combination of outcomes or events for each of the fire safety sub-systems. This requires the systematic combination of feasible outcomes or events for the sub-systems. This may be achieved by considering the multiple performance outcomes for each of the 6 sub-systems

Some of the different factors to be considered and that will lead to the specification of unique fire scenarios are listed below:

- Fire Initiation and Development (SS1)
  - Smouldering/Non-flashover/Flashover Fires
- Smoke Development and Management (SS2)
  - Smoke management: Operation/non-operation
  - If operative: successful or not
- Fire Spread and Management (SS3)
  - Doors open/closed
  - Barriers: successful or not
  - External spread via windows: yes or no
- Detection and Suppression(SS4)
  - Detector activation: successful or not
  - Sprinkler Operation/non operation
  - If operative: successful or not
- Occupant Response and Avoidance (SS5)
  - Awake or Asleep
  - Response to cues: successful or not

## Chapter 6 - Methods of Evaluation

- (implications also for time of occurrence)
  - If not initially successful, subsequent response to other cues: successful or not
  - Different times for evacuations

- Fire Service Response (SS6)
  - Rescue: successful or not
  - Extinguishment: successful or not
  - Different times for arrival and setup

A simple representation of the possible events associated with a design involving both sprinkler and barrier sub-systems, for the case of a potential flashover fire, is shown in Figure 6.3. From these events it is possible to characterise three fire scenarios, Fire Scenarios I, II and III, which are briefly described below:

- Fire Scenario I: Control of fire growth in the enclosure of fire origin because of successful operation of the sprinkler.
- Fire Scenario II: Control of fire growth to the enclosure of fire origin because of the success of the barriers in preventing the spread of fire when the sprinkler has failed to control the growth of the fire.
- Fire Scenario III: Spread of fire to the adjoining enclosures because the failure of the sprinkler sub-system to control the growth of the fire and the failure of the barriers to control the spread of fire to adjoining enclosures.

Once the events associated with each fire scenario have been defined it is then possible to quantify the occurrence of the fire scenario by defining the times of occurrence of key events along a time line (see Section 6.5.3).

Further information on the systematic development of fire scenarios, based on the use of event trees is presented in Section 6.9.4.2.

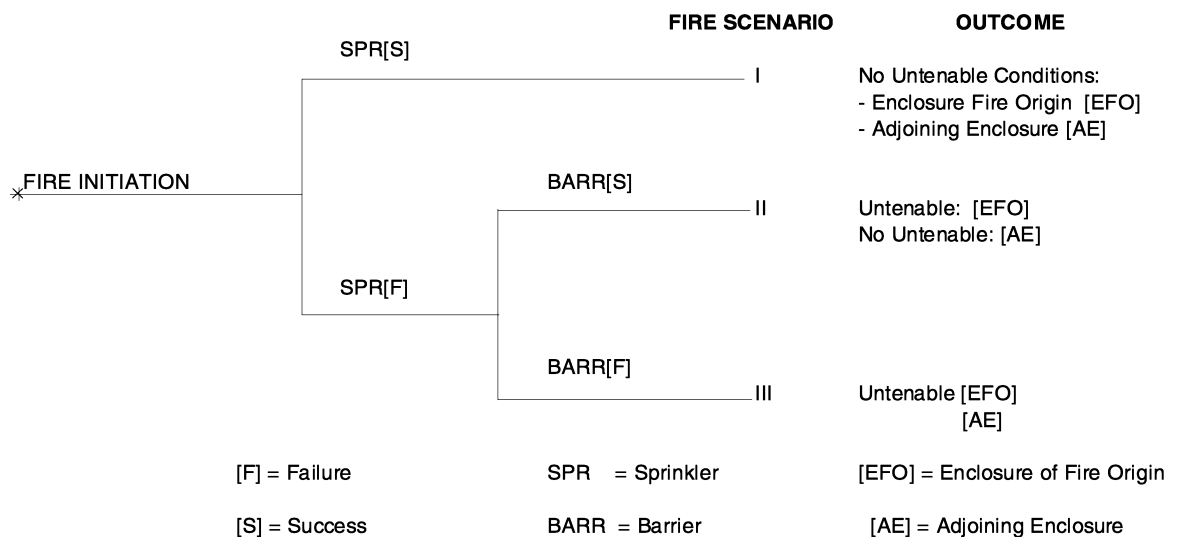
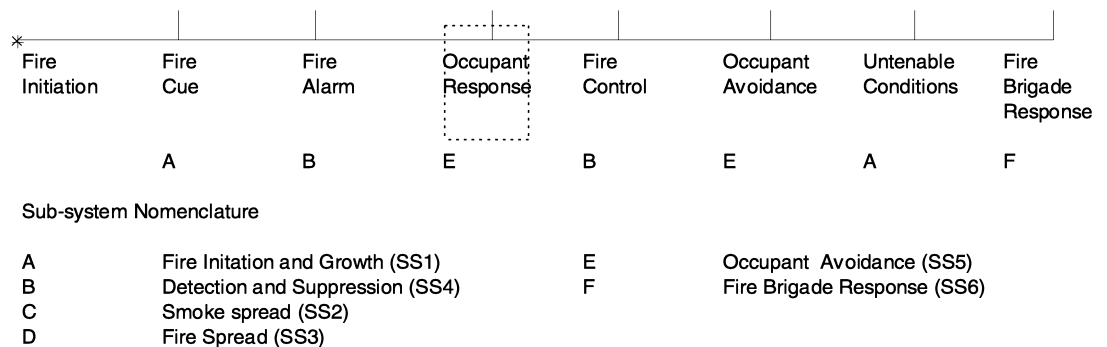

**Figure 6.3 Representation of the Possible Events Associated with a Trial Concept Design Involving Sprinkler and Barrier Sub-systems**

**6.5.3 Quantify fire scenario occurrence**

A quantitative fire scenario is defined by considering the ignition, growth, decay and burnout of a particular fire, under defined outcomes or events associated with the fire safety system, and estimating the times of occurrence of key events associated with each sub-system and inserting these times of occurrence on a common time line. The engineering models presented in Chapters 8 to 13 inclusive can be used to estimate the times of occurrence of the key events along the time line.

A possible time line for a flashover fire scenario in the enclosure of fire origin is shown in Figure 6.4. A quantitative fire scenario is defined by inserting the calculated times of occurrence of critical events for a particular outcome associated with each sub-system on a time line.



**Figure 6.4 Possible Time Line for a Flashover Fire Scenario in the Enclosure of Fire Origin**

**6.6 Principles for Evaluation**

**6.6.1 General**

The 6 sub-systems are used to generate times and probabilities of key events that are used in the Level 1, 2 and 3 evaluations described in this Chapter.

Inevitably, it is necessary to make simplifying assumptions in the evaluation process and the sub-systems have been developed in the context of the need to provide practical design solutions. Fire engineering models are used to estimate the performance of the component or sub-system for the defined quantitative fire scenario(s). This has meant that the results of all research have not been included in these Guidelines. For instance, no account is taken of the effects of smoke and toxic gases on the speed of movement during the evacuation process. For simplicity a simple go/no-go situation is assumed: ie. that the occupants will either be able to escape relatively unimpeded or will be trapped due to the onset of untenable conditions. A more detailed analysis could be carried out taking account of the effects of visual and physical impairment. However, particular care should be taken to ensure that the validity of the initial assumptions (such as fire growth rate) justifies such refinement of the modelling techniques. There should be consistency in both the nature of the assumptions and the level of sophistication adopted throughout the analysis.

**6.6.2 Fire engineering models**



The performance of components, sub-systems or the building fire safety system can be estimated by the use of fire engineering models which are based upon physical, chemical and thermodynamic relationships derived from engineering models and/or empirical correlations. An analytical fire engineering model with a given set of boundary conditions will always produce the same result.

Substantial effort has gone into the development of such models, particularly those intended to predict fire growth, spread of smoke, structural fire resistance, heat detector response and egress analysis. Various engineering models are available for evaluating the development and effects of fire and the movement of people. These models are described in the appropriate sub-systems (see Chapters 8 to 13 inclusive).

### **6.6.3 Selection of parameters**

One approach to Trial Concept Design evaluation is to consider single or multiple fire scenarios in isolation (Methods of Evaluation, Levels 1 and 2; see below) and invoke the appropriate evaluation criterion for each scenario. When considering quantitative fire scenarios in isolation, it is usually the practice to choose the worst credible conditions for assigning values to the variables. However, it should be recognised that, when considering several scenarios, using a series of unlikely events would lead to an over-conservative design. On the other hand, using average values for the variables would be perceived as leading to a non-conservative design. Accordingly, a characteristic design value should be adopted that is higher than the average value. For the purposes of this document an 80% fractile should be considered for variables such as fire load density and fire growth rate.

### **6.6.4 Treatment of Uncertainty**

Fire engineering models provide a useful indication of the development and effects of fire but the nature of fire is such that the results are unlikely to be precise. Normally, well formulated models would be expected to provide conservative predictions within their range of application. However, in some cases, which involve Trial Concept Designs based on absolute criteria, there may be no factor of safety inherent within the model, and the technique should be used with extreme care. In all situations, where there is any doubt as to the validity of a model, the user should establish from the literature how the experimental work was carried out and decide whether the design situation is markedly different.

There are also levels of uncertainty associated with data for models (this applies to both deterministic and probabilistic data).

Under such levels of uncertainty (either for the models or the data) it is usual, as a minimum, that adequate factors of safety should be applied to represent the level of uncertainty and to ensure a conservative result is obtained.

When uncertainty exists, either with the models or the data, it is usually appropriate to conduct a sensitivity analysis to determine if changes in the model assumptions/applicability or the data will lead to a different decision being arrived at for the acceptable Trial Concept Design. Also it may be appropriate to conduct an uncertainty analysis, as described in Appendix 6B.

### **6.6.5 Data requirements**

The acquisition of reliable data can be one of the most important (and possibly time-consuming) tasks in performing a fire engineering evaluation. The use of reliable data is essential to the performance of a realistic fire engineering evaluation. In the absence of specific data the assumptions and data must be conservative, based on sound engineering judgement and agreed during the FEDB. The type of information required for an evaluation can broadly be classified into four main groups:

- models and data
- building data
- fire statistics (applicable to Level 3 evaluation only)
- system reliability data (applicable to Level 3 evaluation only).

Additional comments on the data required for conducting a fire engineering evaluation is given in Section 6.9.5.

All fire protection sub-systems may on occasions fail for a variety of reasons such as lack of maintenance, random mechanical failures, inability to cope with an unusually high fire severity, or a lower than expected performance capacity of the sub-system. This should be recognised, as a minimum, in the development of the various fire scenarios. In addition, for Level 3 evaluation, data is required on the reliability of each sub-system; this type of data should be obtained from the manufacturer or, where appropriate, published statistics or from a fault tree analysis of the sub-system.

### **6.6.6 Sensitivity analysis**

Design based on engineering models may involve uncertainties. Usually, these can be dealt with by taking a conservative approach, eg. selecting a fire growth rate that is faster than would normally be expected. However, if this approach is not suitable then the primary sources of uncertainty should be addressed; these are associated with:

- (a) the input parameters, ie. uncertainties associated with the initial qualitative interpretation of the problem in the FEDB;
- (b) the simplification needed to develop the fire engineering models and hence make the analysis more easily managed.

An indication of sensitivity may be gained by investigating the response of the output parameters to changes in the individual input parameters. This will act as a guide to the level of accuracy required of the input data.

The objective of a sensitivity study should be not simply to check the accuracy of the results but also to investigate the criticality of individual parameters. For example, it may be important to establish how critical a sprinkler sub-system is to the final consequences. If a single sub-system or assumption is shown to be critical to the overall level of safety achieved, consideration should be given in the analysis to the effects should such a sub-system fail and be rendered ineffective. Under such circumstances, the need to provide additional sub-system(s) should become apparent.

The simplifications and assumptions made in the FEDB to aid the full analysis should be tested for their criticality to the fire safety design. For example, it may have been assumed in the specification of the fire scenarios that a compartment remains a compartment during fire conditions, and that the possibility of an open door may be ignored. However, an alternative fire scenario would include consideration of the open door assumption. Thus, a sensitivity test on the qualitative components of fire safety design is possible.

In a Level 3 probabilistic analysis, the sensitivity analysis is quite critical and must be undertaken. Parameters that may be important in a sensitivity analysis and any cost-benefit study are:

- rate of fire starts
- ratio of smouldering/flaming/flashover fires
- choice of initial fire growth rate for each scenario
- probability of sprinkler operation (if applicable)
- probability of success of the smoke management sub-system
- door open/closed
- fire brigade response

### **6.7 Sub-system Equivalence Evaluation (SEE): Level 1 Comparative Performance of a Component/Sub-system: Single/Multiple Fire Scenarios**

#### **6.7.1 Scope**

The scope of this section outlines the method of evaluation to be adopted for Sub-system Equivalence Evaluation (SEE). This method of evaluation is intended to establish equivalence between essentially equal performing elements of the fire safety system. This is generally established by comparing the performance (usually specified in terms of the time of occurrence of certain key events) of an alternative Trial Concept Design with the performance of a deemed-to-satisfy strategy as specified in the regulations.

#### **6.7.2 Studies**

The performance of sub-systems or components can be estimated by the use of engineering models which are based upon physical, chemical and thermodynamic relationships derived from scientific theories and empirical correlations (refer to Section 6.2).

#### **6.7.3 Evaluation criteria**

**Comparative criteria.** For Sub-system Equivalence Evaluation (Level 1) it is required to firstly identify the basic performance requirement (for example, time of operation or failure) of a component or a sub-system (which is acting in isolation); it is not necessary to consider the effect of the component or sub-system on the safety of the occupants. The performance is then quantified in terms of the time of operation (for example, a smoke detector) or the time of failure (for example, a barrier) for a proposed component or sub-system. The criterion for satisfactory performance is that both the delivered performance and the time of operation or failure of the Trial Concept Design component or sub-system under investigation must provide at least the same or better delivered performance and time of operation or failure as the equivalent component or sub-system which is specified in regulations. In addition, it is desirable that the reliability of the alternative Trial Concept Design is at least as good as the reliability of the equivalent component or sub-system which is specified in regulations.

#### **6.7.4 Procedure**

The procedure to undertake Sub-system Equivalence Evaluation (Level 1) is as follows:

- Select the sub-system for investigation

## **Chapter 6 - Methods of Evaluation**

- Identify the appropriate fire scenarios for investigation (refer Section 6.5.2) from the FEDB
- Quantify the fire scenarios (refer Section 6.5.3) for the original prescriptive solution
- Quantify the fire scenarios for the proposed alternative trial concept design
- Estimate the performance of the component or sub-system for the particular quantitative fire scenarios
- Evaluate whether the acceptance criteria is satisfied for each scenario.

The procedure to undertake Sub-system Equivalence Evaluation is shown in Figure 6.5

Engineering models are used to estimate the performance of the component or sub-system for the defined quantitative fire scenario(s). Since the study is comparative, the adoption of reasonable assumptions (for example, regarding fire growth rates and the choice of smoke modelling procedures) is unlikely to have a significant influence on the outcome (that is, whether an alternative design is satisfactory or not).

Before it can be demonstrated that a solution offers at least the same level of performance as a prescriptive code there should be a clear understanding of the intent of the regulations. During the Fire Engineering Design Brief it will be necessary to identify or agree upon the performance objectives of the regulations in respect of the component or sub-system under investigation. Once this has been done, Trial Concept Design solutions may be developed that address the specific objectives. The engineer should demonstrate that the solution proposed will provide an equivalent performance which will be at least as effective and reliable as the conventional approach specified in the regulations.

Examples of specific evaluation criteria that may be considered relevant for a Sub-system Equivalence Evaluation (Level 1 ) include:

- Alarm
  - Time of activation of an alarm
  - Loudness of alarm
- Smoke Management Sub-system
  - Time of activation of a smoke management sub-system
  - Time of failure of a smoke management sub-system
  - Effectiveness of smoke control measures
- Sprinkler Sub-system
  - Time of activation of a sprinkler
  - Effectiveness of control/extinguishment
- Barrier Sub-system
  - Time of failure of a barrier.

In determining the times of occurrence of key events of the component or sub-system, consideration must be given to realistic fire scenarios; including various events for fire, environmental and loading conditions.

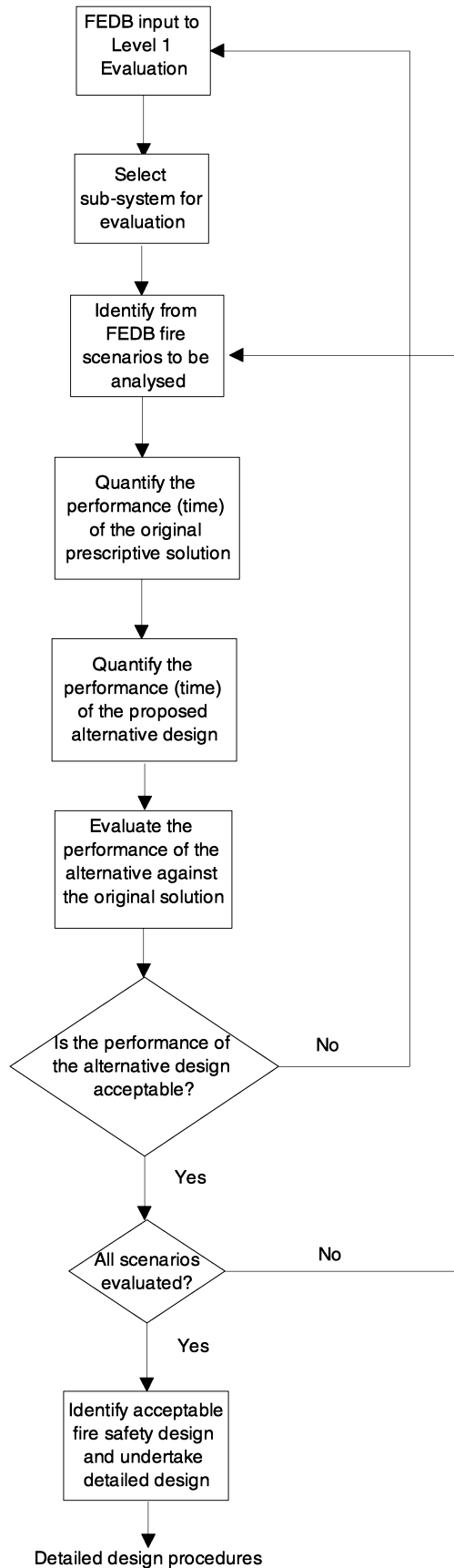

**Figure 6.5 Evaluation Framework for Estimating Sub-system Equivalence (Level 1)**

### **6.8 System Performance Evaluation (SPE): Level 2 Single/Multiple Fire Scenario(s) not Combined**

#### **6.8.1 Scope**

The scope of this section outlines the method of evaluation to be adopted for System or Sub-system Performance Evaluation (SPE). This evaluation methodology is intended to establish equivalence between essentially different sub-systems of the fire safety system. This is generally established by comparing the performance (usually specified in terms of the level of occupant safety) of an alternative Trial Concept Design with the performance of a deemed-to-satisfy strategy as specified in the regulations. It is appropriate where an alternative Trial Concept Design is composed of essentially different elements to those which are contained within the deemed-to-satisfy strategy as specified in the regulations.

In this Section single or multiple quantitative fire scenarios are considered in isolation. No attempt is made to combine the results obtained from each scenario.

#### **6.8.2 Studies**

The performance of sub-systems or components can be estimated by the use of engineering models which are based upon physical, chemical and thermodynamic relationships derived from scientific theories and empirical correlations (refer to Section 6.6.2).

#### **6.8.3 Evaluation criteria**

**General.** The criterion for safety is that for any given quantitative fire scenario the Available Safe Escape Time (ASET) is greater than the Escape Time (ESCT). The time ASET is dependent upon the acceptance criteria set for untenable conditions in the FEDB.

**Comparative Criterion.** It can often be difficult to establish the level of safety achieved in absolute terms. However, it may be relatively straightforward to demonstrate that for the selected quantitative fire scenario(s) the design provides a level of safety, the ratio of ASET to ESCT, which is equivalent to that in a building that complies with the regulations. For instance, in a large exhibition hall it may be desired that travel distances be extended; as a consequence there will be increased evacuation time. However, if the hall has a high roof it may be possible to demonstrate that the time required for the smoke to fill the large volume will more than compensate for the expected increase in evacuation time. Since the study is purely comparative, in general reasonable assumptions (for example, regarding fire growth rates and the choice of smoke modelling procedures) are unlikely to have a significant influence on the outcome.

Before it can be demonstrated that a solution offers at least the same level of safety as a prescriptive code there should be a clear understanding of the intent of regulations. During the Fire Engineering Design Brief (FEDB) it will be necessary to consider the intentions of each recommendation as a particular provision may have more than one objective. Once this has been done, alternative design solutions may be developed that address the specific underlying objectives. The engineer should demonstrate that the solution proposed will be at least as effective and reliable as the conventional approach specified in the regulations.

**Absolute Criterion.** When using the absolute criterion it is necessary to demonstrate that the safety criterion is achieved for the selected quantitative fire scenario(s); usually the "worst credible case" assumptions are selected for the quantitative fire scenario(s). There are inevitably a range of uncertainties in fire engineering calculations that may stem from the initial assumptions and errors in the calculation procedures. It may, therefore, be

appropriate to include explicit safety factors in the analysis to compensate for such errors. However, it is important to avoid using excessive safety factors when the basic assumptions and calculation procedures are known to be highly conservative. Higher safety factors may be appropriate where the consequences of a fire could be particularly severe. In particular, higher safety factors are recommended in the evaluation of tenability conditions when large numbers of the public are likely to be present. The Fire Engineering Design Brief should consider whether it is appropriate to include explicit safety factors within the evaluation or whether the assumptions and calculation procedures are intrinsically sufficiently conservative.

### **6.8.4 Procedure**

#### **6.8.4.1 General.**

The general procedure to undertake System Performance Evaluation (Level 2) is as follows:

- Select the sub-system(s) for investigation
- Identify the appropriate fire scenarios for investigation (refer Section 6.5.2) from the FEDB
- Quantify the fire scenarios (refer Section 6.5.3)
- Estimate the performance of the component or sub-system for the particular quantitative fire scenarios
- Investigate whether the evaluation criteria is satisfied for each scenario.

The procedure to undertake System Performance Evaluation is very similar to that outlined for a Level 1 evaluation (see Figure 6.5).

When considering life safety objectives using the System/sub-system Performance Evaluation (Level 2) approach, the design should be based upon the prevention of fatal casualties for each of the scenarios considered. Guidance on appropriate criteria for life safety is given in Chapter 4.

In a System/Sub-system Performance Evaluation (Level 2) the task is to demonstrate that all persons can leave a threatened part of a building without being subjected to untenable conditions and are ultimately able to leave the building and its vicinity. The evaluation of the Trial Concept Design should ensure that the occupants can leave a threatened area without assistance from the fire service. However, the evacuation of people with disabilities to a place of safety outside the building may require the assistance of the emergency services.

In determining the escape time, consideration must be given to detection, pre-movement and flow times as outlined in Section 6.8.4.3. Escape times should be based on the maximum anticipated occupancy and should take account of the mobility of the occupants, walking speed, size and number of exits, and queuing times required to enter a place of safety. Models to calculate evacuation times are given in Chapter 12.

#### **6.8.4.2 Tenability conditions.**

Given in Chapter 4 are tenability criteria for exposure to toxic gases, heat and loss of visibility. Failure of structural elements before the evacuation is complete can also present a threat to life. The study should, therefore, address all likely causes of death or incapacitation in fire such as:

- (i) loss of visibility;
- (ii) exposure to toxic products;

- (iii) exposure to heat;
- (iv) structural failure.

The FEDB should attempt to establish which potential threats are significant and require quantification. However, in most circumstances it will be loss of visibility due to the spread of smoke that determines the initial threat to life and consequently the time to untenable conditions. In some circumstances the operation of an extinguishing system may spread smoke downwards, adversely affecting visibility in the very early stages of a fire. However, if it can be shown that the fire will be extinguished before excessive temperatures or toxic conditions are reached then loss of visibility will not be a life safety criterion.

Examples of conditions which may lead to untenable conditions:

- Loss of load-bearing capacity. One limiting state for a barrier or structure is the loss of load-bearing capacity. Calculations should take into account a heat exposure model, a thermal response model and a structural response model.
- Loss of smoke control. Calculations should be based on fire growth rate, smoke build up, spread rates and activation times of systems.
- Internal fire spread. Calculations should take account of fire growth, heat build-up, radiation levels on to the surrounding fuel bed, pilot and spontaneous ignition temperatures of the surrounding fuel bed and the rate of heat release of combustible material or burning rate. The data and modelling techniques needed to calculate the rate of fire spread across wall and ceiling linings are often not available. In most circumstances it will therefore be necessary to rely upon traditional classification procedures to judge the acceptability of lining materials.
- External fire spread. Calculations should take account of the area of radiating heat, the extent of flame projection, through draught conditions for the fire in the enclosure of fire origin, and the distance of the building from adjacent sites. Guidance on the evaluation of fire spread beyond the enclosure of fire origin is given in sub-system 3.

### **6.8.4.3 Absolute criteria**

Let the available safe egress time (ASET) be a function of the time to untenable conditions as follows:

$$ASET = \alpha t_{unt} \quad (6.0)$$

where

$t_{unt}$  = time to untenable conditions

$\alpha$  = safety factor for untenable conditions

Essentially, when designing for life safety, the aim is to ensure that ASET is greater than the escape time ESCT, namely:

$$ASET > ESCT \quad (6.1)$$

and



$$ESCT = \lambda_{esc} \cdot t_{esc} \quad (6.2)$$

where:

$\lambda_{esc}$  is a safety factor applied to the unfactored escape time.

$t_{esc}$  is the unfactored escape time;

$$t_{esc} = t_{alm} + \Delta t_{pre} + \Delta t_{flow} \quad (6.2a)$$

where:

$t_{alm}$  is the alarm time;

$\Delta t_{pre}$  is the pre-flow time (includes response and coping time);

$\Delta t_{flow}$  is the occupant flow duration.

The inhalation of smoke and toxic gases can impair movement but may not cause total incapacitation which would prevent escape. In principle it would be possible to take account of the inhalation of toxic gases on the speed of the escape. However, in most circumstances, if the design is sufficiently conservative, such a detailed evaluation is not justified. For the purposes of design it may generally be assumed that the response of the occupants is unchanged until untenable conditions are achieved, at which time movement ceases.

#### 6.8.4.4 Safety factors.

In many design procedures factors of safety are applied to reflect the uncertainties in the data or model accuracy. If a fire may put a large number of people at risk it may be appropriate to include additional factors of safety within the design. For example, in buildings where large numbers of the public are likely to be present who may be unfamiliar with all of the available exit routes (eg in shopping complexes) it may be considered appropriate to include an explicit safety factor to take account of uncertainties in the distribution of occupants between the available exits.

It is recommended that  $\lambda_{esc}$  is greater than 1. In large and complex public buildings such as shopping malls a value for  $\lambda_{esc}$ , of at least 2 may be considered appropriate. This value of  $\lambda_{esc}$ , may be reduced if it can be shown that, by virtue of the layout of the building, management systems (see Section 12), adequacy of signage, etc., the occupants will make full use of all of the available exits.

The time to untenable conditions safety factor  $\alpha$  (<1), accounts for uncertainties in both the accuracy of the model and the data used. When selecting a value for  $\alpha$  consideration should be given to whether conservative values have already been used for the data, such as rate of fire growth and/or fire load density.

#### 6.8.4.5 Comparative criteria.

An alternate method of evaluation to ensure that the Trial Concept Design will provide a level of safety at least equivalent to that achieved by designs specified in the regulations. In a comparative study there is generally no need to introduce explicit safety factors as

any uncertainties in the calculation procedures are likely to apply to both the base case (design complying with the regulations) and the new design.

If in the base case the escape time  $t_{esc}$  is estimated as 2 1/2 minutes and the  $t_{unt}$  is calculated to be 5 minutes, this implies an inherent factor of 2 (on  $t_{esc}$ ).

If the escape time ( $t_{esc}$ ) is raised to 3 minutes because of the increased travel distances it will be necessary to increase the *ASET* to 6 minutes, ie so that:

$$\frac{t_{unt}}{t_{esc}}(\text{base case}) < \frac{t_{unt}}{\Delta t_{esc}}(\text{new design}) \quad (6.3)$$

This increase in  $t_{unt}$  may be achieved in several ways, eg. by the provision of a large smoke reservoir in the roof, by a smoke extraction system or by controls on combustible materials that would reduce the expected rate of fire growth.

If  $t_{unt}/t_{esc}$  for the base case is less than 1, care should be taken to establish whether an appropriate fire growth rate has been chosen for the calculations and it should be ensured that the base case does not represent an intrinsically unsafe design.

#### 6.8.4.6 Barrier/Structural failure.

In buildings subject to phased evacuation, hospitals, etc., the occupants may need to remain in the building for an extended period while firefighting operations take place. It is therefore recommended that where the failure of the barrier/structure will threaten the life of the occupants, who may have to remain in the building for a prolonged period, the barrier/structural assembly should be capable of resisting the fire for the duration that the occupants are threatened.

### 6.9 System Risk Evaluation (SRE): Level 3 Multiple Fire Scenarios Combined Using a Probabilistic Methodology

#### 6.9.1 Scope

The scope of this section outlines the method of evaluation to be adopted for System Risk Evaluation (SRE). This evaluation methodology is intended to establish equivalence between essentially different fire safety systems. This is generally established by comparing the performance (usually specified in terms of risk to life safety and life-cycle fire costs) of an alternative fire safety system Trial Concept Design with the performance of a deemed-to-satisfy system design strategy as specified in the regulations. This method of evaluation is appropriate where an alternative fire safety system Trial Concept Design is composed of essentially different elements to those which are contained within the deemed-to-satisfy design as specified in the regulations and the cost-effective combination of such elements is not immediately obvious. For example if one design was composed of fire-resisting construction and another design was composed of both sprinklers and fire-resisting construction; what should the reduced level of fire-resisting construction be for the second design? Such a question can best be resolved by a Level 3 method of evaluation.

This method of evaluation involves the consideration of multiple quantitative fire scenarios (as described in Section 6.5 and as used in Levels 1 and 2 evaluation), the results of which are then combined using a probabilistic risk-assessment methodology.

### **6.9.2 Studies**

For design purposes, the factors which influence fire development cannot be determined in advance of the fire occurring. Each time a fire occurs the outcome will vary according to the conditions prevailing at the time. It is impossible, for instance, to predict with certainty when and where a fire will occur, what the ventilation conditions are, whether the sprinkler, detection or barriers will be fully operational or whether such sub-systems are totally effective in performing their functions given that they are operational. Accordingly, it becomes essential to consider fire scenarios and their consequences when sub-systems both work successfully and fail. Under such circumstances the appropriate strategy is to treat fire as an uncertain event and assess multiple quantitative fire scenarios and the possible outcomes in a probabilistic manner using the techniques of probabilistic risk assessment (PRA).

#### **6.9.2.1 Performance Parameters**

The performance of a fire safety system can be quantified by a number of performance parameters. For example, two important performance factors associated with the fire safety system are:

- occupant safety
- through-life costs

These two performance factors can be quantified by the use of the following performance parameters (Beck: 1989) :

- Risk-to-Life Safety (ERL) parameters (described below, and Section 6.9.4.5)
- Fire-cost Expectation (FCE) parameter (described in Section 6.9.4.6)

However, other performance factors can be important for a particular design. These performance factors include:

- Risk of fire spread to adjoining properties
- Risk of life safety to fire brigade personnel
- Risk of environmental damage
- Business interruption/loss of stock and customers.

By estimating probabilities of failure and success of component and sub-systems and frequencies of occurrence to unwanted events it is possible to estimate the realistic performance of the fire safety system by estimating the level of occupant safety in terms of the Expected Risk-to-Life Safety (ERL) parameter. A probabilistic risk assessment analysis is undertaken by considering multiple quantitative fire scenarios. The number of quantitative fire scenarios considered depends on both the complexity of the system being considered and the level of the analysis being undertaken. Each scenario considered is assigned a probability of occurrence and the number of occupants exposed, if any, to untenable conditions is estimated. The expected number of occupants exposed to untenable conditions for each scenario is simply the product of the probability of occurrence of the quantitative fire scenario times the number of occupants exposed to untenable conditions associated with the scenario under investigation. The ERL parameter is obtained by summing each of the component terms for the expected number of occupants exposed to untenable conditions and dividing this sum by the product of the total number of occupants in the building and the design life of the building.

The Expected Risk-to-Life Safety Parameter is defined below:

$$\text{ERL} = \frac{\text{Expected Number of Deaths over Design Life of Building}}{\text{Building Population} \times \text{Design Life of Building}} \quad (6.4)$$

The amount of modelling, statistical data and effort required to accomplish a full probabilistic risk assessment analysis is considerable and, given the present state of the art, can usually only be justified in certain cases.

Owing to limitations in both the reliability of models and the associated data together with gaps in statistical data it is often difficult to reliably estimate an absolute value of fire risk associated with a particular building. However, when a risk-based methodology is used in a comparative framework as outlined below, in conjunction with a sensitivity analysis, then the need for highly accurate probability estimates is reduced provided a comprehensive sensitivity analysis is conducted. Under such circumstances some confidence can be achieved in the design recommendations obtained from a risk-based methodology.

A risk-based methodology provides the only systematic basis for identifying those combinations of sub-systems (that is, the fire safety system), which includes specifying or assessing the adequacy of essentially different fire protection strategies (eg. sprinklers and/or compartmentation), which will deliver deem-to-satisfy levels of safety. A risk-based methodology also provides a systematic framework for identifying cost-effective design solutions by considering expected losses over the life of the building in conjunction with the initial capital costs and running costs.

### **6.9.2.2 Application of risk-cost assessment models**

Risk-cost assessment models for fire safety design in buildings have been under development for a number of years. They can be characterised as those models which quantify the risk to life safety and the through-life costs association with fire in buildings (Beck: 1994).

Risk-cost assessment models can be used to (Beck and Yung: 1994)

- a) Identify alternative fire safety system Trial Concept Design configurations which give equivalent performance to the existing code requirements (in terms of ERL values), but at a lower net cost (FCE value); that is, the alternative designs are more cost-effective.
- b) Provide a performance-based approach to design for fire which is applicable to both proposed building designs and also existing buildings.
- c) Appraise both existing building regulation requirements, proposals to change code requirements, and investigate whether consistent cost-effective performance is provided by the various regulation requirements.
- d) Specify alternative, but nevertheless equivalent, design solutions in the regulations; that is, introduce greater flexibility into the regulations.

### **6.9.3 Evaluation criteria**

It is not possible to eliminate totally the risk of death or injury from fire. In a probabilistic risk assessment study it is not appropriate or valid, at this stage of development of PRA, to compare a numerical estimate of risk (for example, the ERL parameter derived from a probabilistic model) with an independently derived risk level. It is more appropriate to undertake a comparative study. The evaluation criterion for identifying an acceptable building fire safety system Trial Concept Design solution is that the ERL value associated with such a design is not greater than the ERL value which is derived from a equivalent design that is specified in the regulations (Beck: 1989). It may also be appropriate to

introduce a cost parameter (for example, the Fire-cost Expectation parameter) as an additional dimension to the evaluation criteria.

### 6.9.4 Procedure

#### 6.9.4.1 General

The general procedure to undertake System Risk Evaluation (Level 3) is based on the integration of the results obtained from the consideration of multiple fire scenarios (quantified). A general framework for undertaking a quantitative risk analysis is outlined below:

- Develop multiple scenarios for evaluation
- Quantify fire scenarios
- Estimate the scenario consequences
- Estimate the risk-to-life safety parameter
- Estimate the fire-cost expectation parameter
- Determine whether the evaluation criteria is satisfied.

The procedure to undertake System Risk Evaluation is show in Figure 6.7.

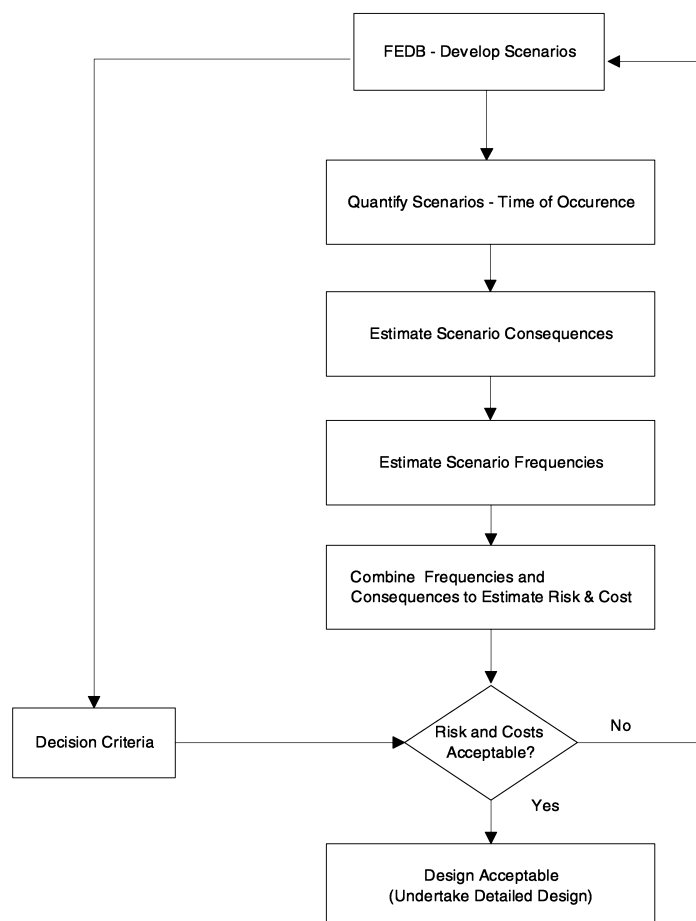

**Figure 6.6 Method of Evaluation for System Risk (Level 3)**

For a general treatment on the development and application of risk assessment methodologies, refer to AICE: 1989. While the material contained in this reference is related to the chemical process industry, the basic framework is equally applicable to the fire safety engineering.

**6.9.4.2 Develop fire scenarios**

It is recommended that the development of multiple scenarios proceed in a systematic manner to assist in ensuring that all relevant fire scenarios are considered (refer to Section 6.5.2). This can be undertaken by systematically changing one event at a time (associated with a given fire scenario). For example, if in one fire scenario it was assumed that the sprinkler operated and successfully extinguished the fire, then the next fire scenario could represent the case when the sprinkler did not operate.

When undertaking System Risk Evaluation (Level 3) the use of event trees is recommended to assist in the systematic development and quantification of multiple scenarios. Event trees provide a simple method to represent the full range of fire scenarios that can occur.

Event trees are constructed by starting with an initial event (for example, fire initiation) and then given that the event has occurred a fork is constructed and branches are added to represent the number of all those immediately succeeding events which can occur. It should be noted that the sum of the probabilities of each of the events at a fork must sum to unity since all possible events are represented at a fork. Each branch at a fork represents the occurrence of an event. Given the occurrence of this event then a new fork is constructed and new branches are constructed to represent all those immediately succeeding events which can occur. The construction of the event tree proceeds in this systematic manner until all events and their combinations have been represented on the event tree.

A path in an event tree is represented by a particular continuous combination of branches (that is, events) and starts with the initiating event and finishes with a final event. There are many paths in an event tree. A fire scenario is defined by the occurrence of a particular path in the event tree.

An outline of some of the fire scenarios which can develop in an enclosure are shown in Figure 6.7; these scenarios are based on the event tree approach.

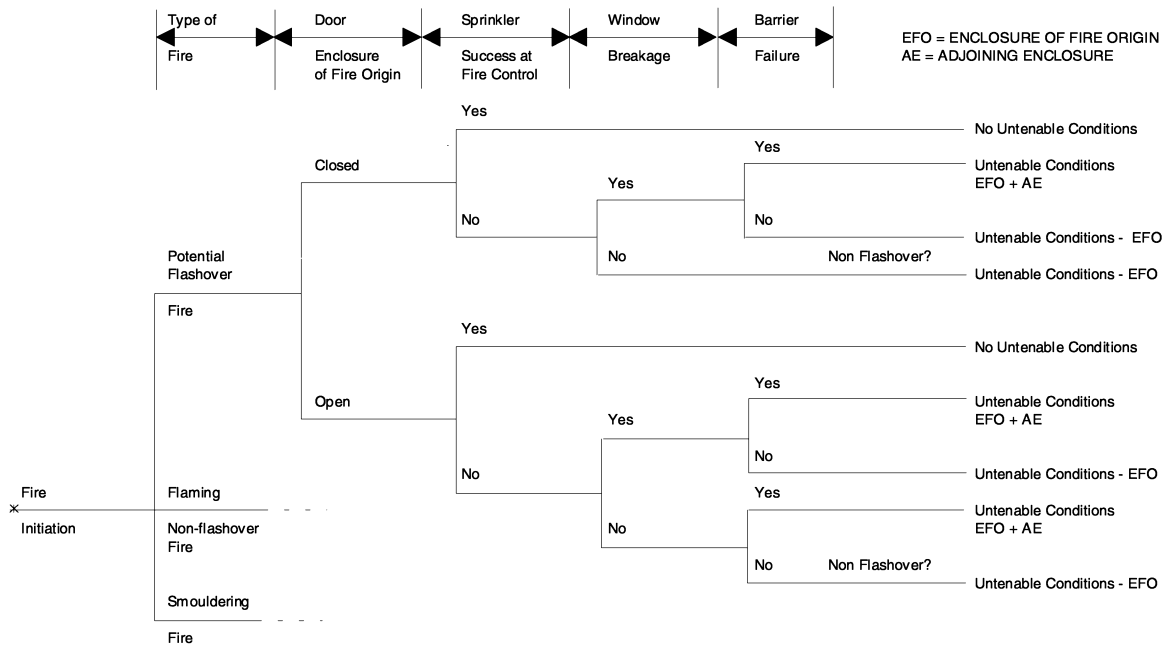

**Figure 6.7 Indicative Fire Scenario Based on an Event Tree Formulation**

When developing fire scenarios it is also appropriate to develop scenarios for occupant detection. Occupant detection scenarios are shown in Figure 6.5; these scenarios are based on the event tree approach. The occupant detection scenarios, shown in Figure 6.5, are based on the following assumptions:

- Occupant Detection I. Occupants are assumed to be able to detect the presence of fire by visual, olfactory and other sensory responses.
- Occupant Detection II. Occupants are assumed to be able to detect the presence of fire by response to an alarm triggered by some form of smoke or thermal detector.
- Occupant Detection III. Occupants are assumed to be able to detect the presence of fire at stage III by response to either new visual, olfactory and other sensory responses, response to an alarm (not previously responded to) or response to warnings issued by others.

Shown in Figure 6.8 are the four assumed occupant detection responses, together with the associated time line for the such responses.

It should be noted that the above conditions are the result of some gross assumptions; other assumptions could be readily justified.

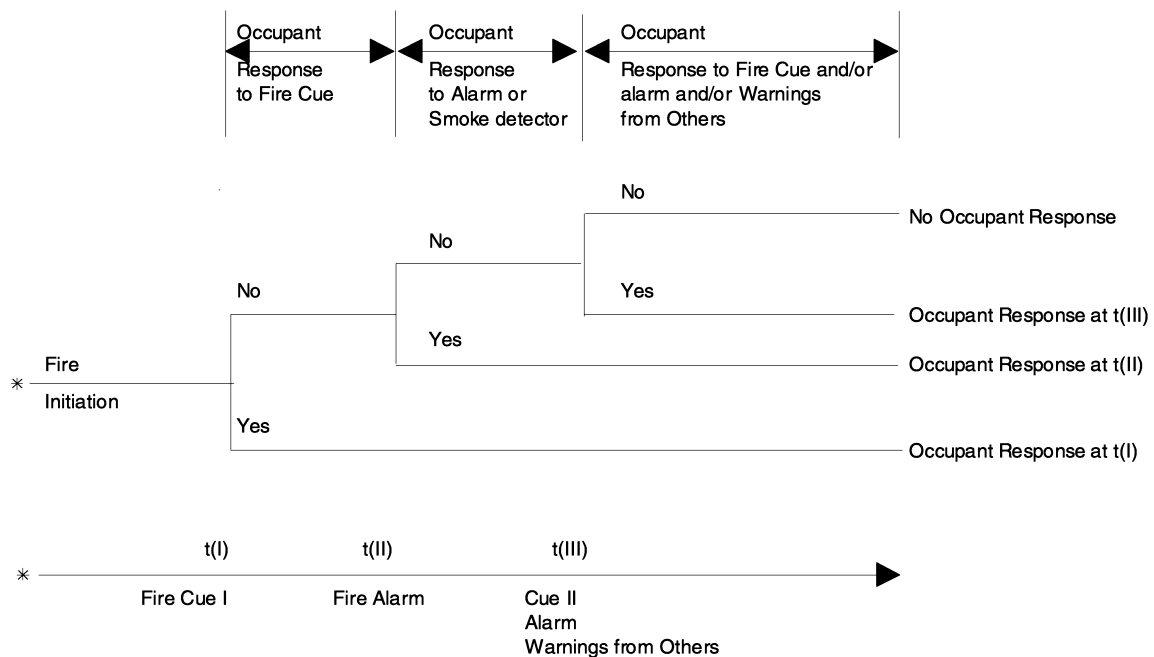

**Figure 6.8 Occupant Responses Based on and Event Tree Formulation plus Associated Timeline**

It should further be noted that each of the above four occupant detection response scenarios (as shown in Figure 6.8) should be combined separately with each of the fire scenarios identified in Figure 6.7. A combined scenario is obtained from the combination of one fire scenario with one occupant detection response scenarios.

### 6.9.4.3 Quantify fire scenario occurrence.

Once the fire scenarios have been specified it is then necessary to estimate the times of occurrence of critical events for insertion on the time line (refer to Section 6.5.3) using appropriate engineering models (refer to Chapters 8 to 13 inclusive).

For the purposes of System Risk Evaluation (Level 3) it is also necessary to estimate the probability of occurrence of each scenario. A given fire scenario represents the occurrence of a particular set of events associated with the fire safety system. Given these circumstances it is possible to determine the probability occurrence of this fire scenario.

The probability of occurrence of the fire scenario can be determined by multiplying the probability of occurrence for each of the events associated with the relevant sub-systems based on the fire scenario under investigation; i.e. the probability of occurrence of events for:

- (i) Fire Initiation and development POE (SS1)
- (ii) Smoke development and management POE (SS2)
- (iii) Fire spread and management POE (SS3)
- (iv) Detection and suppression POE (SS4)
- (v) Occupant response and avoidance POE (SS5)
- (vi) Fire brigade communication and response (SS6)

Hence, the probability of a given fire scenario is defined as follows:

$$\text{POE[Fire Scenario]} = \text{POE[SS1]} \times \{\text{POE[SS2]} \times \text{POE[SS3]} \times \text{POE[SS4]} \times \text{POE[SS5]}\} \quad (6.5)$$

In some cases a particular sub-system may not be relevant to the fire scenario; in such a case, set the probability of occurrence for that non-relevant sub-system to unity.

#### **6.9.4.4 Estimate scenario consequences.**

Associated with each scenario it is possible to define two consequences for the occupants; namely, occupant safety or occupant number of deaths; where:

- Occupant Safety is defined as:  
When no occupants are exposed to the occurrence of untenable conditions for the particular enclosure under investigation.
- Occupant Number of Deaths is defined as:  
The number of occupants remaining in the enclosure under investigation at the time of occurrence of untenable conditions.

The Number of Deaths, for a given quantitative fire scenario, is calculated from the following equation:

$$N(D) = N(O)_{\text{INIT}} - N(O)_{\text{EXIT}} \quad (6.6)$$

where:

$N(D)$  is the number of deaths for the assumed fire scenario;

$N(O)_{\text{INIT}}$  is the initial number of occupants expected to be in the threatened area;

$N(O)_{\text{EXIT}}$  is the number of occupants able to escape to safety in the available safe escape time (ASET).



To estimate the expected number of fatalities for each scenario (required for the life-risk analysis of the next section), then for each scenario considered, two parameters must be obtained; namely

- Probability of occurrence of the fire scenario
- Number of people exposed to untenable conditions.

These two parameters are combined to give the expected number of fatalities.

The expected number of deaths,  $END_i$ , for a particular quantitative fire scenario may be estimated from the following equation:

$$END_i = POE [\text{Fire Scenario}] \times N (D) \quad (6.7)$$

where:

$POE[\text{Fire Scenario}]$  is the probability of occurrence for the events of the specified fire scenario developing following ignition.

$N(D)$  is the Number of Deaths and is represented by the number of occupants exposed to untenable conditions.

### **6.9.4.5 Risk-to-life safety.**

There will generally be more than one way in which a fire at a specified location may develop and pose a threat to the occupants. The risk associated with a particular fire location (source) is, therefore, the sum of the risks over all fire scenarios and all potentially threatened enclosures - rooms or spaces within a building (target locations).

The overall risk associated with a particular building is the sum of the risks for all the potential fire sources within that building. The overall risk-to-life safety associated with a particular building design can be estimated from the sum of the risks associated with each fire scenario considered in the analysis.

For small fires that are initiated in an enclosure  $i$ , having a floor area of  $A_f$ , and where such fires are generated according to a Poisson process, then the mean rate of occurrence per year of small fires,  $w$ , is as given below:

$$w = R_i \times A_f \quad (6.8)$$

where:

$R_i$  is the rate of a fire starting in an enclosure (number of fire starts/m<sup>2</sup>/year).

The probability distribution of the uncertain number of small fires that are initiated in  $i$ ,  $v$ , during the design life of the building ( $O$ ,  $t_D$ ) is Poisson; where the probability distribution is defined as follows:

$$P(\tilde{V} = v) = \frac{e^{-wt_D} \times (wt_D)^v}{v!} \quad (6.9)$$

## Chapter 6 - Methods of Evaluation

The expected loss of life in a building, ELLB, over the design life of the building, for fires that are initiated in  $i$ , is given by the following generalised equation:

$$\left[ \begin{array}{c} \text{Expected} \\ \text{Life Loss} \\ \text{in} \\ \text{Building} \\ \text{for Fires} \\ \text{Starting} \\ \text{in } i \text{ over} \\ \text{Period} \\ \text{(O, } t_D) \end{array} \right] = \left[ \begin{array}{c} \text{Probability} \\ \text{of } v \text{ Fires} \\ \text{Starting in} \\ \text{ } i \text{ Period} \\ \text{(O, } t_D) \end{array} \right] \times \left[ \begin{array}{c} \text{Expected} \\ \text{Number} \\ \text{of Deaths} \\ \text{for Fire} \\ \text{Starting} \\ \text{in } i \end{array} \right] \times \left[ \begin{array}{c} \text{Number} \\ \text{of Fires} \\ \text{Starting} \\ \text{in } i, \end{array} \right]$$

$$ELLB(i) = \sum_{v=1}^{\infty} P[v = v] \times END(i) \times v \quad (6.10)$$

Accordingly, the expected loss of life in a building, ELLB, over the time interval  $(O, t_D)$  for fires initiated in all compartments, is given by the following equation:

$$ELLB = \sum_{i=1}^I ELLB(i) \quad (6.11)$$

where  $I$  is the number of enclosures in the building

The expected risk to life, ERL, is defined according to the following equation:

$$ERL = \frac{ELLB}{OP \times t_D} \quad (6.12)$$

where:  $OP$  = Number of occupants defined to be in the building at the commencement of a fire

$t_D$  = Design building life, years.

To produce an exhaustive measure of the risk to life it would be necessary to consider every combination of fire source, fire scenario and target location within the building. However, the computational effort required increases with the number of sources, scenarios and targets considered. The simplification of the problem by the FEDB team (see Section 4) is therefore an essential precursor to carrying out a comprehensive PRA.

### 6.9.4.6 Fire-cost expectation.

Using the procedures presented in these Guidelines it is also possible to estimate the extent of damage that may result from a fire. This information may then be used to estimate potential monetary losses and enable a cost-benefit study to be carried out to

establish the value of installing additional fire protection measures. In this case monetary losses are used as the measure of potential consequences.

When using such considerations it is recommended that the overall fire cost associated with a particular design be estimated. The Fire-cost Expectation is defined below (Beck: 1989):

Fire-cost Expectation (present value), FCE

$$\text{FCE} = \begin{array}{l} \text{Capital cost} \\ \text{associated} \\ \text{with} \\ \text{active and} \\ \text{passive fire} \\ \text{protection} \end{array} + \begin{array}{l} \text{Annual costs for} \\ \text{inspection and} \\ \text{maintenance of} \\ \text{fire equipment} \end{array} + \begin{array}{l} \text{Expected cost of} \\ \text{building and} \\ \text{contents} \\ \text{fire losses} \end{array} \quad (6.14)$$

The design objective should be to minimise the Fire-cost Expectation consistent with achieving the appropriate risk to life safety value.

The estimation of the Fire-cost Expectation parameter can proceed in a similar manner to the estimation of the Expected Risk-to-life Safety parameter. Namely, that for each fire scenario considered the consequences are estimated; however, in this case the consequences are expressed in terms of monetary outcomes. Simply, the expected monetary consequence is estimated as the product of the probability of occurrence of the fire scenario times the monetary consequences of the scenario. The expected monetary consequences for each scenario are then summed. Details on the calculation of expected losses are given in other references; for example Warren Centre Report, Chapter 1, 1989 (Warren Centre : 1989).

### **6.9.4.7 Evaluation criteria.**

Once the risk-to-life safety and fire-cost expectation parameters have been determined the adequacy of the proposed Trial Concept Design can be evaluated against the assessed performance of the required design specified by the regulations (refer to Section 6.9.3).

### **6.9.5 Data required**

(i) **General.** The acquisition of reliable data can be one of the most important (and possibly time-consuming) tasks in performing a fire engineering evaluation. This is no different when performing a risk assessment.

The use of reliable data is essential to the performance of a realistic risk evaluation. In the absence of specific data the assumptions and data must be conservative, based on sound engineering judgement and agreed during the FEDB. The type of information required for a PRA can broadly be classified into four main groups:

- models and data
- fire statistics
- building data
- system reliability data.

(ii) **Model and data.** Information regarding the development of fire scenarios and their possible consequences may be evaluated on the basis of the analytical procedures detailed in Section 6.2.2 and the sub-systems (see Sections 8 to 13 inclusive). The reliability of both engineering models and the associated data are relevant.

(iii) **Fire statistics.** The likelihood of a fire occurring within a particular type of building should be established on the basis of statistical data from buildings of similar use and location. Where no specific data appropriate to the building under consideration are available regarding the numbers of fires, the data presented in Table 7.3 and Appendix 7B may be used as a guide.

(iv) **Building data.** Surveys are available to quantify key items of the PRA such as fractile fire loads and occupancy levels. These are described in Chapter 7. The continued development of a fire and the potential consequences will depend upon a number of factors such as:

- (i) the availability of combustibles and the fractile fire load;
- (ii) the imposed structural loads;
- (iii) the number of occupants present at any given time.

(v) **Reliability data.** All fire protection sub-systems may on occasions fail for a variety of reasons such as lack of maintenance, random mechanical failures, inability to cope with an unusually high fire severity, or a lower than expected performance capacity of the sub-system. Data regarding the reliability of each sub-system type should be obtained from the manufacturer or, where appropriate, published statistics or from a fault tree analysis of the sub-system.

Examples of fire control sub-systems for which reliability data may be required are:

- detection response;
- smoke control operation;
- extinguishing operation;
- breaches of compartmentation (eg insufficient fire stopping, fire doors being propped open at time of fire, etc).

In addition, it will be necessary to have data of the probabilistic response of occupants to various fire cues and alarms.

### **6.9.6 Other factors**

#### **(i) Common mode failures**

In some instances the failure of one part of the system can have an adverse effect on the efficiency of another fire protection measure: eg. an open fire door will not only be an ineffective barrier to fire spread but may also lead to failure of a gaseous extinguishing system due to loss of agent. Particular care must be taken by the FEDB team and those responsible for the PRA to ensure that any such common mode failures are identified and accounted for in the analysis.

#### **(ii) Simplification**

Although a large number of factors may potentially contribute to the development and consequences of a fire, in practice some of the factors will be insignificant. By carefully selecting when and where to apply calculations, and then tailoring the calculation technique to the problem under consideration, a flexible, pragmatic and equally safe solution can be developed.

The PRA should be preceded by the FEDB (see Chapter 4) for two main reasons:

- to ensure that the problem is fully understood and that the analysis addresses the relevant aspects of the fire safety system; and
- to simplify the problem and reduce as far as possible the computational effort required.

It is appropriate to simplify the problem so that the effort of calculation will be expended in the most productive areas. The objective is to ensure that the quantified evaluation procedure is comprehensive enough to allow fire-safety decisions to be made whilst making efficient use of the time and resources available.

### **6.10 Final Reporting**

Once quantification and evaluation of an acceptable design has been completed, a full and final report should be prepared.

This report should address all the issues outlined in the reporting section of the FEDB stage (see Chapter 4).

It is critical that the final report show not only the assumptions made in characterisation (Chapter 7) and all the steps of calculation for each sub-system (Chapters 8 to 13), but also the details of the overall Level 1, 2 or 3 analysis and evaluation of the overall fire safety system design against the acceptance criteria.

### **References**

American Institute of Chemical Engineers, "Guide-lines for Hazard Evaluation Procedures", 1985 (3).

Beck, V. R. et al, "A systematic approach to fire safety design of buildings", Fire Safety and Engineering, Part 1, Book 1, Technical Papers, The Warren Centre, The University of Sydney, December 1989.

Beck, V. R., "Performance based fire safety design - recent developments in Australia", Fire Safety Journal, Vol 23, pp 133-158., 1994.

Beck, V.R. & Yung, D., "The development of a risk-cost assessment model for the evaluation of fire safety in buildings", Fire Safety Science - Proceeding of the Fourth International Symposium, International Association for Fire Safety Science, Ottawa, Canada, pp 817-828, 13-17 June, 1994.

## Chapter 7 - Characterisation of Building, Contents, People and Environment

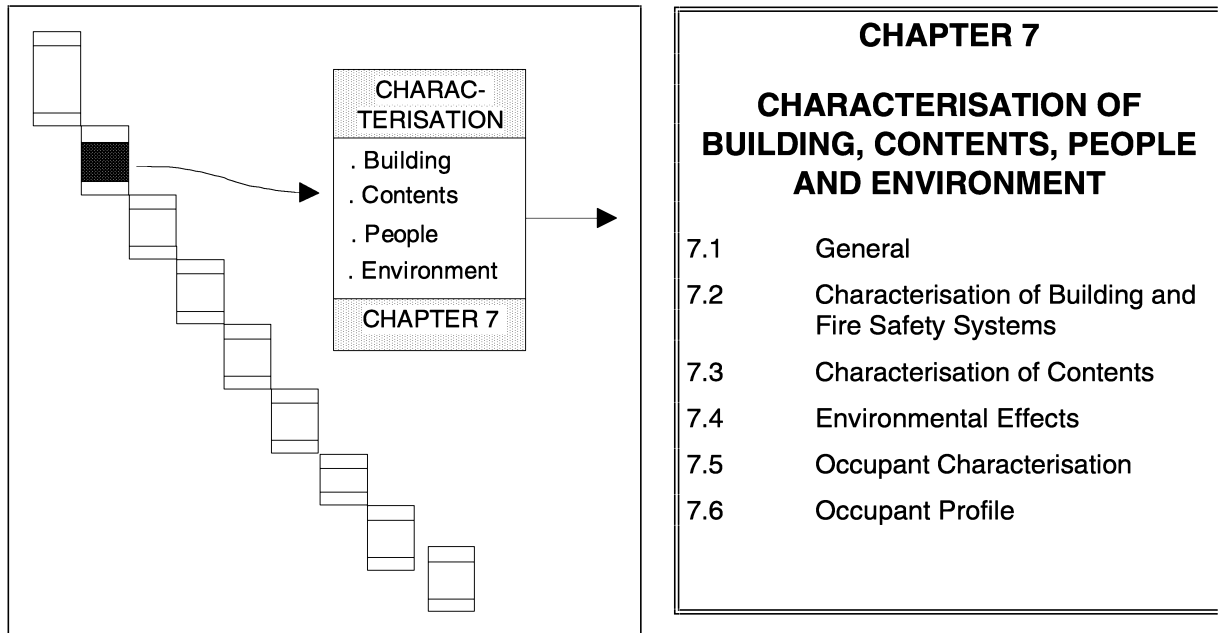

### 7.1 General

Before a fire safety engineering assessment of a building can begin it is necessary to assemble design information on the fabric and structure of the building, the fire safety systems, the contents, the occupants and the environment. This information affects the likelihood of a fire occurring, how the fire spreads and its potential for causing damage to humans and property.

The design information will be of two kinds:

- (a) Factual data already available for a number of parameters.
- (b) Information which must be converted or assumed in the absence of hard information.

The fire safety engineer must make it clear in the assessment whether the design parameter data do or do not include safety factors, and if so their values, to allow for plausible worst case scenarios. This allows the level of safety to be assessed.

A building may comprise one room, such as a single storey warehouse or, at the other extreme, several hundred rooms and many circulation spaces, as in a hospital. It is not feasible or necessary to characterise all rooms/spaces in a multi-room building. The FEDB should consider which enclosures need to be treated explicitly.

The FEDB requires that the building designer (e.g. architect) explains to the fire safety engineer the concept and relevant details. These will include details of building usage, activities within rooms, location of circulation spaces in normal use, and the emergency evacuation strategy, if any. During this review it may become clear to the experienced fire safety engineer that there are several fire hazards which represent life-threatening fire scenarios which require in-depth consideration if they cannot be removed by, for instance, the simple addition of a fire barrier or an automatic fire suppression system. The engineer can then focus the characterisation activity in those areas of a building likely to affect the life threat scenario(s) identified. A similar procedure is followed if the design objective is other than safety of life, i.e. safety of property or environment.

## **Chapter 7 - Characterisation of Building, Contents, People and Environment**

### **7.2 Characterisation of building and fire safety systems**

#### **7.2.1 Building Characterisation**

Design data needed for the building and fire safety systems before a fire safety engineering assessment can begin is typified in the list below. The list is not exhaustive.

- (a) position of building
  - location of building relative to site boundary, other buildings and other fire hazards orientation
- (b) fabric and structure of the building
  - overall size and shape of building and storey heights
  - positions and sizes of windows and other areas of low fire resistance in the external envelope
  - location of fire separating elements (e.g. walls, doors, shutters, floors and roofs) and their fire resistance
  - location of load bearing elements of construction and their fire resistance (e.g. beams and columns)
  - location and dimensions of vertical and horizontal shafts and ducts and fire resistance of enclosing elements
  - nature of construction (e.g. materials forming the frame, walls, partitions, floors, suspended ceilings and roof)
  - thermal properties of lining materials, especially thermal conductivity, density and specific heat
  - configuration of hidden voids (e.g. voids associated with hollow walls, floors and roofs, suspended ceilings and raised floors)
  - location of main entrance(s) and normal circulation routes
  - location and width of stairways and other spaces used for normal circulation within the building
  - location and height of fire fighting stairways, fire fighting lifts and protected lobbies
  - location of fire exit routes and fire resistance of enclosing elements

Characterisation needs to be undertaken for each enclosure of interest.

When the use and occupancy of a building is expected to vary with time, characterisation should be undertaken for each likely variation. The appropriate characteristics should be used in a Level 3 analysis and each of the scenarios be combined taking into account the effective life of each configuration. For a Level 1 or 2 analysis the worst-case configuration should be assumed.

#### **7.2.2 Characterisation of fire safety systems**

During the FEDB the assumed characteristics and performance of the selected fire safety systems to be considered shall be defined. The extent of the definition needs to be consistent with the level of analysis and provide all the input parameters required for the analysis of each sub-system.

Typical factors to be considered are:

- structural fire resistance
- fire properties of lining materials
- availability of fire fighting water inside/outside building
- number and location of external fire hydrants
- number of fire appliances used in first attendance
- equipment carried on fire appliances

## **Chapter 7 - Characterisation of Building, Contents, People and Environment**

- access points for fire appliances
- travel distance and route to fire site from fire brigade
- zones covered by fire detection/alarm systems
- positions of fire alarm call points
- zones covered by automatic sprinklers
- location and vent area of manual and automatic smoke vents
- zones covered by pressurisation systems

It may not be possible to characterise all of these factors.

### **7.3 Characterisation of contents**

#### **7.3.1 General**

The nature and amount of information needed on the contents depends on the design objective. It will be different if, on the one hand, the objective is to assess the risk to life while, on the other hand, the objective is to minimise damage, for instance, to equipment by smoke containing corrosive gases.

The following information may be needed:

- Amount of combustible materials(e.g. expressed in MJ).
- Porosity of combustible contents, as this affects the burning rate.
- Relative positions of fuel packages, as this affects fire spread between fuel packages.
- Monetary value of contents.
- Susceptibility of contents to damage by smoke, heat and water.
- Fire protection of contents (e.g. papers in a fire resisting cabinet).
- Amount of liquid fuels and gases and how stored.

#### **7.3.2 Fire load**

The fire load within a room or compartment will influence the duration and severity of a fire. Fire load data are therefore required in order to evaluate the potential for structural failure and fire spread beyond the compartment of origin (see Chapter 10).

Work has been carried out in Europe to establish the fire load densities in a range of different occupancies. In this sub-clause the results of this work are summarised and characteristic values are presented for a number of different types of occupancy. Where it is desired to establish fire load data for a specific type or use of a building, guidance is provided on the survey requirements.

The effective fire load density is generally expressed in MJ.m<sup>-2</sup> of floor area but may be expressed in terms of an equivalent weight of wood as a function of floor area. The effective fire load may be utilised in sub-system 3 (see Chapter 10) to establish the duration and severity of a fire.

Several methods may be used to establish the effective fire load in a room or compartment:

- (a) direct measurement/assessment;
- (b) statistical survey;
- (c) use of characteristic fire load density.



## **Chapter 7 - Characterisation of Building, Contents, People and Environment**

### **7.3.2.1 Direct measurement.**

Where the fire loading is unlikely to change significantly over the design life of the building the fire load density may be estimated from a knowledge of the weight and calorific value of the contents. Calorific values for a range of common materials are given in tables 7.1.

$$q_{ki} = \frac{\sum m_c H_c}{A_f} \quad (7.1)$$

where

$q_{ki}$	is the fire load density for the compartment (in MJ m <sup>-2</sup> );
$m_c$	is the total weight of each type of combustible material in the compartment (in kg);
$H_c$	is the calorific value of each combustible material (in MJ kg <sup>-1</sup> ) [see Table 7.1 and the following equation.]
$A_f$	is the total internal floor area of the compartment (in m <sup>2</sup> ).

Where wet or damp materials are present the effective calorific value may be modified to take account of the moisture content by use of the equation:

$$H_c = H_u(1 - 0.01M) - 0.025M \quad (7.2)$$

where

$H_c$	is the effective calorific value of the wet material (in MJ kg <sup>-1</sup> );
$H_u$	is the calorific value of the dry material (in MJ kg <sup>-1</sup> );
$M$	is the Moisture content (in % by dry weight).

### **7.3.2.2 Statistical survey**

To determine statistically the characteristic fire load density from surveys of similar buildings the following points are recommended.

- (a) A minimum of five buildings should be considered.
- (b) Buildings investigated should have comparable use, and similar size and contents.
- (c) The buildings should be located in the same country as the building under study or in regions of similar social and economic conditions.

When using published fire-load-density data, care should be taken to ensure that the sampling and evaluation techniques used are appropriate to the particular fire engineering study.

### **7.3.2.3 Characteristic fire loads**

Values for characteristic fire load densities in various occupancy types are presented in Appendix 7A. These data are taken from Switzerland and may be applicable to buildings in Australia (Buchanan: 1994). Alternatively the values contained within Table 7.2 may be used. Other sources of information relating specifically to offices, dwellings and computer centers include:

- i. NFPA Fire Protection Handbook (Campbell: 1991: 6-77)
- ii. Australian Construction Services (Calvert: 1987)
- iii. Eckler: 1978

## Chapter 7 - Characterisation of Building, Contents, People and Environment

Table 7.1 Calorific values of typical materials (solids and liquids)

<b>Solids</b>	<b>Calorific value MJ kg<sup>-1</sup></b>
Anthracite	34
Asphalt	41
Bitumen	42
Cellulose	17
Charcoal	35
Clothes	19
Coal, coke	31
Cork	29
Cotton	18
Grain	17
Grease	41
Kitchen refuse	18
Leather	19
Linoleum	20
Paper, cardboard	17
Paraffin wax	47
Foam rubber	37
Rubber isoprene	45
Rubber tyre	32
Silk	19
Straw	16
Wood	18
Wool	23
Particle board	18

<b>Gases</b>	<b>Calorific value MJ kg<sup>-1</sup></b>
Acetylene	48
Butane	46
Carbon monoxide	10
Hydrogen	120
Propane	46
Methane	50
Ethanol	27

<b>Liquids</b>	<b>Calorific value MJ kg<sup>-1</sup></b>
Gasoline	44
Diesel oil	41
Linseed oil	39
Methanol	20
Paraffin oil	41
Spirits	29
Tar	38
Benzene	40
Benzyl alcohol	33
Ethyl alcohol	27
Isopropyl alcohol	31

<b>Plastics</b>	<b>Calorific value MJ kg<sup>-1</sup></b>
ABS	36
Acrylic	28
Celluloid	19
Epoxy	34
Melamine resin	18
Phenol formaldehyde	29
Polyester	31
Polyester fibre reinforced	21
Polyethylene	44
Polystyrene	40
Polyisocyanurate foam	24
Polycarbonate	29
Polypropylene	43
Polyurethane	23
Polyurethane foam	26
Polyvinyl chloride	17
Urea formaldehyde	15
Urea formaldehyde foam	14

## Chapter 7 - Characterisation of Building, Contents, People and Environment

Table 7.2 Fire load density in different occupancies

Densities in Megajoules per square metre				
Occupancy	Average (MJ m <sup>-2</sup> )	Fractile *		
		80%	90%	95%
Dwelling	780	870	920	970
Hospital	230	350	440	520
Hospital storage	2000	3000	3700	4400
Hotel bedroom	310	400	460	510
Offices	420	570	670	760
Shops	600	900	1100	1300
Manufacturing	300	470	590	720
Manufacturing and Storage* < 150kg m <sup>-2</sup>	1180	1800	2240	2690
Libraries	1500	2250	2550	---
Schools	285	360	410	450

\* The 80% fractile is the value that is not exceeded in 80% of the rooms or occupancies.

+ Storage of combustible materials.

Note: The values given in Table 7.2 include only the variable fire loads (i.e. building contents). If significant quantities of combustible materials are used in the building construction this should be added to the variable fire load to give the total fire load.

### 7.3.2.4 Protected fire loads

Combustible materials stored within containers that have a degree of fire resistance (e.g. steel filing cabinets) will be protected, to some degree, and will not be fully consumed in a fire. The effective fire load may, therefore, be less than that of the total quantity of combustible materials present. The extent of this reduction in effective fire load will depend upon:

- (a) fire temperature;
- (b) fire duration;
- (c) container integrity;
- (d) the nature of the combustibles.

These effects are often difficult to quantify unless the container has been specifically designed to be fire resisting. However, for steel filing cabinets containing paper and cardboard the calorific value may be taken to be 40% of that of the total contents.

### 7.3.3 Fire starts

The frequency of fire starts may be estimated as a generic frequency for each type of occupancy from fire statistics.

AS 2577 provides a classification system for a broad range of occupancies against which fire brigades provide statistics on fire occurrence. Appendix 7B provides statistical data from the Australian Incident Statistics on occurrence of fires in different occupancies over a four year period. The rate of starts per year for a particular occupancy can then be determined.

Alternatively the results shown in Table 7.3 (BSI: 1995) may be used as a first approximation.

## Chapter 7 - Characterisation of Building, Contents, People and Environment

**Table 7.3 Overall Probability of Fire Starting in Various Types of Occupancies**

Occupancy	Probability of starts per occupancy starts $y^{-1}$
Industrial	$4.4 \times 10^{-2}$
Storage	$1.3 \times 10^{-2}$
Offices	$6.2 \times 10^{-3}$
Assembly entertainment	$1.2 \times 10^{-1}$
Assembly non-residential	$2.0 \times 10^{-2}$
Hospitals	$3.0 \times 10^{-1}$
Schools	$4.0 \times 10^{-2}$
Dwellings	$3.0 \times 10^{-3}$

The above rate of fire start values are comparable with the figures quoted in the National Building Fire Safety Systems Code for apartments and offices of  $22 \times 10^{-6}$  /m<sup>2</sup>/year and  $8.9 \times 10^{-6}$  /m<sup>2</sup>/year. Assuming an average area for offices and apartments of 1000 m<sup>2</sup> and 100 m<sup>2</sup> yields a rate of fire starts of  $8.9 \times 10^{-3}$  starts/year and  $2.2 \times 10^{-3}$  starts/year respectively.

The data provided in Table 7.3 has been categorised independently of compartment size. However, the probability of a fire starting is likely to increase with building size and for a given occupancy may be expressed as a function of building area. Where data is available on the number of fire starts per unit floor area these should be used in preference to the generalised information presented in Table 7.3, Table 7.4 contains information relating the frequency of fire starts to the floor area (BSI: 1995).

**Table 7.4 Probability of Fire Starting within Given Floor Area for Various Types of Occupancy**

Occupancy	Probability of fire starting starts $y^{-1}$ m <sup>2</sup> floor area
Offices	$1.3 \times 10^{-5}$
Storage	$3.3 \times 10^{-5}$
Public assembly	$9.7 \times 10^{-5}$

The probability of a fire starting, however, is not linearly related to floor area; the larger the building the lower the frequency of fire starts per square metre of floor area. In general terms the probability of a fire starting in a building can be represented as follows (BRI: 1995):

$$P_i = a A_F^b \quad (7.3)$$

where:

## Chapter 7 - Characterisation of Building, Contents, People and Environment

$P_i$	is the probability of a fire starting (in starts yr <sup>-1</sup> )
$A_F$	is the floor area of the enclosure (in m <sup>2</sup> )
a	is a constant related to the occupancy
b	is a constant related to the occupancy

Table 7.5 gives values of the constants a and b for a number of different types of industrial premises.

**Table 7.5 Probability of Fire Starting in Various Types of Occupancy of a Given Size**

Occupancy	a	b	Probability of fire in building of floor area 1000 m <sup>2</sup> starts yr <sup>-1</sup>
All manufacturing industry	0.0017	0.53	0.066
Selected industries			
Food, drink, tobacco	0.0011	0.60	0.069
Chemical and Allied	0.0069	0.46	0.165
Mechanical engineering	0.0001	0.75	0.018
Electrical engineering	0.0006	0.59	0.035
Vehicle manufacture	0.0001	0.86	0.038
Metal goods	0.0016	0.54	0.067
Textiles	0.0075	0.35	0.084
Paper, printing, publishing	0.00007	0.91	0.038
Other manufacturing	0.0084	0.41	0.143

Table 7.8 provides an indication of the floor area involved in fire for different types of building occupancy, based on NSW fire statistics between 1964-73.

### 7.3.4 Choice of fire scenario

The characterisation of a fire, whether it be inside or outside the building, is a most important activity. The fire can be regarded as having the same importance as the heart in the human body in so far that it acts as the pump on which everything else (i.e. the organs) depend. If fire is characterised in the wrong way, perhaps by underestimating its severity (peak temperature, duration, heat release or intensity of emitted radiation) then the application of engineering methods to predict the effects of the fire elsewhere in or near the building may produce results which do not accurately reflect the true impact of the fire hazards.

Design fires may be needed for a wide range of scenarios. These may be categorised as internal fires or external fires. Examples of types of internal fire scenarios include:

- room corner fires;
- single burning item fires, e.g. a piece of furniture, a wastepaper basket;
- cable tray or duct fires;
- special rooms, e.g. atria, tunnels, exhibition halls;

## **Chapter 7 - Characterisation of Building, Contents, People and Environment**

- roof fires (in and under the roof);
- fires within the facade resulting from an internal fire.

Examples of types of external fire scenarios include:

- fires from neighbouring buildings;
- fires from other external fuel packages such as woodlands, yard storage, vehicles. These may be in contact with or separate from the exposed building;
- fires on a roof, e.g. by flying brands and by hot working operations on the roof, and by spread of fire over a fire separating wall which projects above roof level.

Before attempting to idealise the fire development it is useful to consider the likely character of the fire. The first stage is to determine the important design fire parameter(s). Are they - rate of heat release, peak value of temperature, smoke mass production or a combination of these? The next stage is to define the design fire parameter(s) as a function of time. These decisions are important. These inputs are required in sub-system 1 to define the selected design fire(s).

Table 7.6 shows, for a number of occupancy types, the first and second most common point of origin, with the number of recorded fires for the period 1964-1973 (ignoring the categories "other" and "other rooms") in NSW.

**Table 7.6 Most common point of fire origin**

<b>First and second most common point of origin for different occupancies (1964-1973)</b>				
<b>Occupancy</b>	<b>First</b>	<b>No.</b>	<b>Second</b>	<b>No.</b>
Permanent dwelling house	Kitchen	2607	Bedroom	2198
Temporary dwelling house	Kitchen	124	Bedroom	78
Residential flat	Bedroom	712	Kitchen	347
Hotel, hostel, etc.	Bedroom	306	Kitchen	80
Dwelling attached to other building	Bedroom	75	Kitchen	71
Office	Plant or service rooms	97	Roof or roof space	37
Shop	Plant or service rooms	457	Kitchen	360
Warehouse	Plant or service rooms	86	Basement	18
Factory	Plant or service rooms	1652	Roof or roof space	185
Public bldg	Plant or service rooms	137	Kitchen	78
Hospital, prison, etc.	Plant or service rooms	44	Bedroom	31
Minor outbuilding	Roof or roof space	204	Plant or service rooms	193
Overall	Kitchen	3737	Bedroom	3424

Table 7.7. shows the point of origin of a number of recorded fires in a range of occupancies. The data is based on NSW fire statistics between 1964-1973.

## Chapter 7 - Characterisation of Building, Contents, People and Environment

**Table 7.7 Type of building & point of origin (1964-1973)**

Type of building	Basement	Roof or roof space	Plant or service rooms	Kitchen	Bedroom	Other rooms	Lift	Flue	Other	TOTAL
Dwelling house permanent	129	564	127	2607	2198	3383	3	301	609	9921
Dwelling house temporary	7	23	6	124	78	143	0	4	136	521
Residential flat	62	67	41	347	712	441	13	12	76	1771
Hotel, hostel, etc	22	28	52	80	306	135	0	11	37	671
Dwelling attached to other bldg	12	21	45	71	75	148	1	10	46	429
Office	18	37	97	14	2	256	16	4	59	503
Shop	77	79	457	360	8	512	7	44	313	1857
Warehouse	18	14	86	2	0	120	1	3	101	345
Factory	99	185	1652	22	2	544	5	61	506	3076
Public bldg	50	69	137	78	4	367	2	14	193	914
Hospital, prison, etc	6	11	44	16	31	53	3	4	13	181
Minor outbuilding	69	204	193	16	8	240	0	37	3167	3934
<b>TOTAL</b>	<b>569</b>	<b>1302</b>	<b>2937</b>	<b>3737</b>	<b>3424</b>	<b>6342</b>	<b>51</b>	<b>505</b>	<b>5256</b>	<b>24123</b>

Appendix 7C Illustrates the analysis that can be undertaken to identify the most common materials first ignited.

The choice of fire scenarios must have a sound statistical basis.

### 7.3.5 Frequency of Fire Starts

The frequency of occurrence of smouldering, flaming and flashover fires can be determined from a study of the area of fire damage, assuming that smouldering fires do not spread to involve a large area or more than one object, and that flaming fires spread to a certain degree but do not spread beyond the room or compartment of fire origin.

Table 7.8 provides the number of fires and floor area involved for various occupancy types. If it is assumed that smouldering fires involve a negligible area, and if the size of a typical compartment is known, the proportion of each type of fire can be determined.

**Table 7.8 1964-1973 Type of building in which fire originated and floor area involved in fire. (NSW fire statistics between 1964-73)**

Type of building	neg. area	<10	<100	<200	<500	<1000	<2000	2000+	TOTAL
Dwelling house permanent	1361	4252	2775	1307	194	23	8	1	9921
Dwelling house temporary	31	283	186	14	7	0	0	0	521
Residential flat	311	900	425	80	46	6	1	2	1771
Hotel, hostel, etc.	129	307	150	31	26	17	5	6	671
Dwell. attached to other bldg	41	151	135	57	38	6	1	0	429
Office	84	199	146	37	24	8	3	2	503
Shop	241	682	538	192	123	48	18	15	1857
Warehouse	28	101	73	37	52	23	19	12	345
Factory	422	1056	738	302	248	184	62	64	3076
Public bldg	96	316	235	111	86	43	18	9	914
Hospital, prison etc.	65	72	28	7	6	3	0	0	181
Minor outbuilding	268	1998	1522	99	35	7	1	4	3934
<b>TOTAL</b>	<b>3077</b>	<b>10317</b>	<b>6951</b>	<b>2274</b>	<b>885</b>	<b>368</b>	<b>136</b>	<b>115</b>	<b>24123</b>

## **Chapter 7 - Characterisation of Building, Contents, People and Environment**

For example, if it is assumed that a typical compartment within a permanent dwelling will be 100 m<sup>2</sup> or less then the proportion of smouldering fires is calculated to be 14%, flaming fire 70% and flashover fires is 16%.

Alternatively, the proportion of each type of fire can be related to the form of ignition data and flame spread data from the Australian National Fire Statistics using the method detailed in the Warren Centre Reports (Warren Centre: 1989: 3.13)

### **7.4 Environmental effects**

#### **7.4.1 General**

Environmental conditions may have an influence on the fire safety design of a building although in most circumstance this effect will be relatively small. However, environmental conditions can have an influence upon the response of heat detectors or the performance of a natural smoke ventilation system. Basic guidance is therefore provided in this sub-clause regarding internal and external temperatures and the calculation of wind-induced pressures.

#### **7.4.2 Effect of wind**

Wind blowing on a building creates a build-up of pressure on the windward face. The wind is deflected around the sides and over the roof of the building, creating a negative pressure, i.e. suction, on areas other than the windward face. Guidance on calculating wind pressures is given in AS 1170. Designers will need to consider the probability of a fire occurring on a day of high wind velocity to achieve a reasonable design.

#### **7.4.3 Wind direction**

In general the wind direction giving rise to the most onerous pressure distribution should be used. However, meteorological data may be used in a probabilistic assessment to evaluate the effects of different wind directions.

#### **7.4.4 External temperature**

For buildings in Australia the following air temperatures are considered to represent suitable extreme values for the purposes of design:

+0°C (winter) and 40 °C (summer)

Designers undertaking a Level 3 analysis should consider the probability of a fire occurring at the same time as a day of extreme temperature.

#### **7.4.5 Internal temperature**

Temperature distribution is not generally uniform throughout a building; however, for the purposes of these Australian guidelines ambient temperature in occupied rooms may generally be assumed to be 23°C.

Where internal temperature may have a major effect, a sensitivity analysis should be carried out taking account of the likely extremes of temperature.



## **Chapter 7 - Characterisation of Building, Contents, People and Environment**

### **7.4.6 Effect of snow**

Build up of snow and ice on roofs may affect the performance of smoke and heat ventilation systems delaying the time of operation.

### **7.4.7 Humidity**

Level of humidity may affect rate of fire development.

### **7.4.8 Internal air movements**

Some large volume buildings, such as exhibition halls, employ conditioned air blowers positioned near the ceiling. The induced air movement can deflect the rising plume of fire gases away from high level smoke and heat detectors thus delaying/preventing their operation. This may mean that special studies have to be made to predict the transient velocities and pattern of air movement after the air movement plant has been shut down. Pre-fire air movement can also be induced by local heat sources which form a rising plume of warm air. All internal air movements should be identified and considered to see if they are likely to affect the effective operation of fire detection and fire suppression systems and/or the way in which the smoke behaves.

## **7.5 Occupant Characterisation**

### **7.5.1 Occupant Characterisation Generally**

Occupants and occupancies have certain characteristics that will influence or determine their ability in response, coping and evacuation activities related to the avoidance of the untenable conditions in a fire related emergency.

Occupants will therefore be "characterised" by a capability rating that is related to response, coping or actual avoidance activities such as evacuation. These capability ratings should be determined using a simplified or detailed procedure.

The occupancy capability factors known as :

- |                                       |      |
|---------------------------------------|------|
| (a) Response capability               | = Rc |
| (b) Coping capability                 | = Cc |
| (c) Evacuation / Avoidance capability | = Ec |

shall be determined from Table 7.9 taking into account the factors noted in the Flow Chart in Figure 12.2 for the simplified procedure or from a complete analysis of the occupants where the factors listed in Table 7.9 are each determined either from actual occupant assessment, via role play or in accordance with an approved occupant capability assessment model (detailed procedure). The glossary of terms used in Table 7.9 can be found in Appendix 7D. If the detailed procedure is used then the occupancy capabilities and occupant avoidance times must be assured via an approved Building Emergency Control System that is managed and audited in accordance with the AS3900 Series, e.g.. AS3901 or 3902.5.

## Chapter 7 - Characterisation of Building, Contents, People and Environment

**Table 7.9 - Occupant Capability Factors - Simplified Procedure**

OCCUPANCY	CAPABILITY WEIGHTING FACTORS							
	A	B	C	D	E	F	G	H
<b>A. Occupant Response</b>	Alertness ✓	Mobility ✓	Social Affiliation	Role	Position ✓	Commitment ✓	Focal Point	Familiarity
⇒Hospitals	*	*	**** ✓	****	*	** ✓	* ✓	** ✓
Apartments	**	*** ✓	* ✓	* ✓	** ✓	****	* ✓	****
Hotels	**	**** ✓	**** ✓	***	** ✓	****	* ✓	* ✓
⇒Nursing Homes	**	*	**** ✓	*** ✓	**	**** ✓	* ✓	**** ✓
Assembly Buildings	*****	**** ✓	*** ✓	** ✓	** ✓	* ✓	*****	**
Sports Stadia and Stations etc.	*****	***** ✓	***	** ✓ ✓	** ✓	* ✓	****	**
Retail	***** ✓	**** ✓	***	*** ✓	**** ✓	***	*** ✓	**
Offices	*****	***** ✓	*** ✓	*****	** ✓	**	**	**** ✓
Industrial	*****	*****	*** ✓	***** ✓	**** ✓	** ✓	* ✓	*****
<b>B. Occupant Coping</b>	Mobility	Communication	Social Affiliation	Role	Commitment	Decisiveness	Position	Familiarity
⇒Hospitals	*	**	**** ✓	**** ✓	* ✓	**** ✓	*	** ✓
Apartments	*** ✓	**	*	*	**** ✓	** ✓	** ✓	**** ✓
Hotels	*** ✓	***	****	***	*** ✓	** ✓	** ✓	* ✓
⇒Nursing Homes	*	**	**** ✓	****	**** ✓	**** ✓	* ✓	*** ✓
Assembly Buildings	**** ✓	***	* ✓	***	* ✓	* ✓	** ✓	**
Sports Stadia and Stations etc.	**** ✓	*** ✓	** ✓	***	**	*	** ✓	** ✓
Retail	**** ✓	***	** ✓	***	*	** ✓	**** ✓	* ✓
Offices	****	*** ✓	**	**** ✓	** ✓	** ✓	*** ✓	*** ✓
Industrial	*****	**	**** ✓	***** ✓	** ✓	*** ✓	***** ✓	***
<b>C. Occupant Evacuation/Avoidance</b>	Familiarity	Signage	Complexity	Population	Mobility	Safety	Social Affiliation	Role
⇒Hospitals	*	**** ✓	**** ✓	*** ✓	*	*** ✓	**** ✓	****
Apartments	****	** ✓	**** ✓	**** ✓	*** ✓	*** ✓	*	* ✓
Hotels	* ✓	***	***	*** ✓	* ✓	**** ✓ ✓	****	*** ✓
⇒Nursing Homes	***	*** ✓	*** ✓	*** ✓	*	** ✓	**** ✓	***
Assembly Buildings	*	** ✓	*	*	**** ✓	*** ✓	** ✓	*** ✓
Sports Stadia and Stations etc.	*	*** ✓	***	*	**** ✓	*** ✓	** ✓	**** ✓
Retail	** ✓	*	*	*	*** ✓	*** ✓	* ✓	*** ✓
Offices	** ✓	*** ✓	***	***	*** ✓	*** ✓	** ✓	***
Industrial	***	*** ✓	***	*****	***** ✓	**** ✓	**** ✓	***** ✓

NOTE 1:           ⇒           Should really be assessed by role play or in the field.

NOTE 2:           Weighting factors (cell scores) marked with (✓) should be multiplied by 0.4, with other factors multiplied by 2.).

### 7.5.2 Occupant capability in response

Occupant response comprises the occurrence of detectable cues, their communication to the occupants and the activities involved in responding to those cues. The occupant response capability rating is determined from the following factors depending on their Pre-

## **Chapter 7 - Characterisation of Building, Contents, People and Environment**

Fire Activity, location, occupant loading, occupant profile, and building characterisation influences :

- (a) Alertness
- (b) Mobility
- (c) Social Affiliation
- (d) Role
- (e) Position
- (f) Commitment
- (g) Focal Point
- (h) Familiarity

Each of the above factors is defined in Appendix 7D. They depend on the general occupant profile which is described in section 7.6. The determination of Occupant Response Capability is described in Chapter 12.

### **7.5.3 Occupant coping capability**

Occupant coping activities involve those resulting from an occupant perceiving that the fire poses an actual threat to the point where the occupant or their group initiates evacuation or avoidance activities. These activities may comprise warning others, gathering belongings, dressing, assisting others, fire fighting, securing the enclosure etc. The extent of these activities will depend on the building emergency control plan and procedures that are in place, the occupant's mental and physical level of ability, training and past experience plus the condition of the environment. The occupant capability to reduce the number and extent of these activities and to concentrate on those that will prove to be effective (reduce tc) is fundamental to the determination of Cc . The occupant capability rating is therefore determined from the following factors :

- (a) Mobility
- (b) Communications
- (c) Social Affiliation
- (d) Role
- (e) Commitment
- (f) Decisiveness
- (g) Position
- (h) Familiarity
- (i) Training

Each of the above factors is defined in Appendix 7D. They also depend on the occupant profile which is defined in Section 7.6. The Occupant Coping Capability rating is determined in Chapter 12.

### **7.5.4 Occupant evacuation/avoidance capability :**

The occupant evacuation/avoidance capability Ec is associated with those activities that are predominantly movement oriented . They comprise evacuation and avoidance activities as follows :

## **Chapter 7 - Characterisation of Building, Contents, People and Environment**

- Evacuation of the fire affected area or enclosure
- Fire fighting / securing area to confine or extinguish the fire
- Wayfinding, Movement, Assisting others etc. through the escape or exit system where the latter is normally external to the enclosure of fire origin .

Ec is therefore determined from the following once the occupant profile has been determined based on the following factors :

- (a) Familiarity
- (b) Visual Access and Signage
- (c) Enclosure - degree of planning
- (d) Population - occupant loading - structure and crowdedness
- (e) Complexity
- (f) Mobility
- (g) Route geometry re safety
- (h) Social Affiliation
- (i) Role

The above factors are defined in Appendix 7D. They also depend on the occupant profile as defined in Section 7.6 and the building characterisation as well as a preliminary definition of the occupant avoidance sub-system especially in terms of the escape or exit system. The Occupant Evacuation Capability rating is determined in Chapter 12.

### **7.6 Occupant Profile**

In order to design and utilise life safety in buildings it is essential to have a detailed knowledge of the capabilities of the occupants to successfully undertake any activities necessary to exercise any particular options. The 'nature of the occupancy' is therefore the critical overall factor as mixed ability may be such that reliance on standard data relating to a 'so-called' homogenous population may be insufficient for the population in question.

In general terms the use to which buildings are put determine the nature of their respective occupancies. It determines the nature and in fact the overall profile of the 'occupants' and hence the strategy used to deliver a realistic life safety option that matches the needs of the occupants. In many buildings the occupant profile can be established from historic data eg. hospitals, offices, etc. whereas in other buildings, it may be less well defined ie. buildings to which the public/community have access. A detailed knowledge of the occupants is essential.

The factors included in the occupant profile are therefore as follows:

- (a) Age, sex, and Mass/Height Ratio
- (b) Distribution
- (c) Occupant Density (m<sup>2</sup>/person)
- (d) Assistance Required
- (e) Education and Training
- (f) Awake or asleep as pre-fire state of being.

Item (a) should be self explanatory except that mass/height ratio is taken as a measure of physical mobility.

## **Chapter 7 - Characterisation of Building, Contents, People and Environment**

Item (b) is critical that people can be physically located in a building at the on-set of an emergency and that the profile of the group is known. In many buildings such as apartments, hotels, offices and the like, this may not cause a problem. For other multi-purpose recreational complexes, superstores, airport terminals and the like the problem can be quite acute. Many operators of these types of buildings have been keeping records which provide reasonable historical data which can provide estimates of distribution over time. It is essential that this is married together to provide net occupant density information (see item (c)).

Item (c) Occupant density has been defined. It is critical that the net occupant density be determined so that evacuation times can be calculated. When this is combined with the overall capability and also the degree of assistance required then the potential movement relocations and flow rates can be determined.

Item (d) Once the overall capabilities of the occupants are known, established from the 'nature of occupancy', it will be possible to identify the numbers or groups of occupants who will require the assistance of others eg. health care premises, aged hostels, places of detention etc. In many other types of buildings, eg. offices and shops, because the occupants are in unfamiliar surroundings, the occupants may require assistance as they may be incapable of undertaking evacuation activities quickly enough in the short space of time available.

Item (e) Education and training is vital as it familiarises people with the characteristics of fire related emergencies and also the correct occupant avoidance/evacuation procedures to follow within a restricted time frame. Simply treated education and training needs of the occupants of buildings can be segmented in terms of those who:

- (a) manage a facility
- (b) staff a facility
- (c) use a facility

Item (f) Training and education increase the level of awareness amongst occupants initially and prepared ultimately. For any program to be effective the occupants must be involved in the process. This program must also be reinforced by signage. Training programs should involve a continuous improvement approach, at least for staff, in public buildings. The optimum procedure here is as follows:

- (i) Prepare evacuation plan and procedures from needs,
- (ii) Establish target times for each phase
- (iii) Trial by evacuation drills (plus familiarising occupants with procedures and routes)
- (iv) Debrief and work out how to improve
- (v) Retrial, etc. and improve.

It is essential that the need for training is established before any of the above can be undertaken.

It should be noted that the preparation of the Occupant Profile relies on the determination of the Occupant Emergency Needs. The results must be incorporated into the 'Fire Design Brief'.

### **References**

Draft British Standard Code of Practice for the Application of Fire Safety Engineering Principles to Fire Safety in Buildings, Warrington Fire Research Consultants, 1995

Buchanan A. H. ed., "Fire Engineering Design Guide", Centre For Advanced Engineering, University of Canterbury, 1994

Campbell, J., "Confinement of fire in Buildings", NFPA Fire Protection Handbook, National Fire Protection Association, 17<sup>th</sup> Edition, 1991

## **Chapter 7 - Characterisation of Building, Contents, People and Environment**

Calvert, E., "Statistical details of fire incidents in Commonwealth Government Computer Installations", Attachment No. 3 to CO Memo D86/432, Australian Construction services, Canberra, June, 1987

Eckler, A. R., "A Statistical Analysis of Bell System Building Fires, 1971 - 1977", The Bell System Technical Journal, Vol. 57, No. 8, October 1978, pp. 2769 - 2796

The Warren Centre, "Fire Safety and Engineering - Technical Papers", Book 1, Chapter 3, p 3:13, 1989



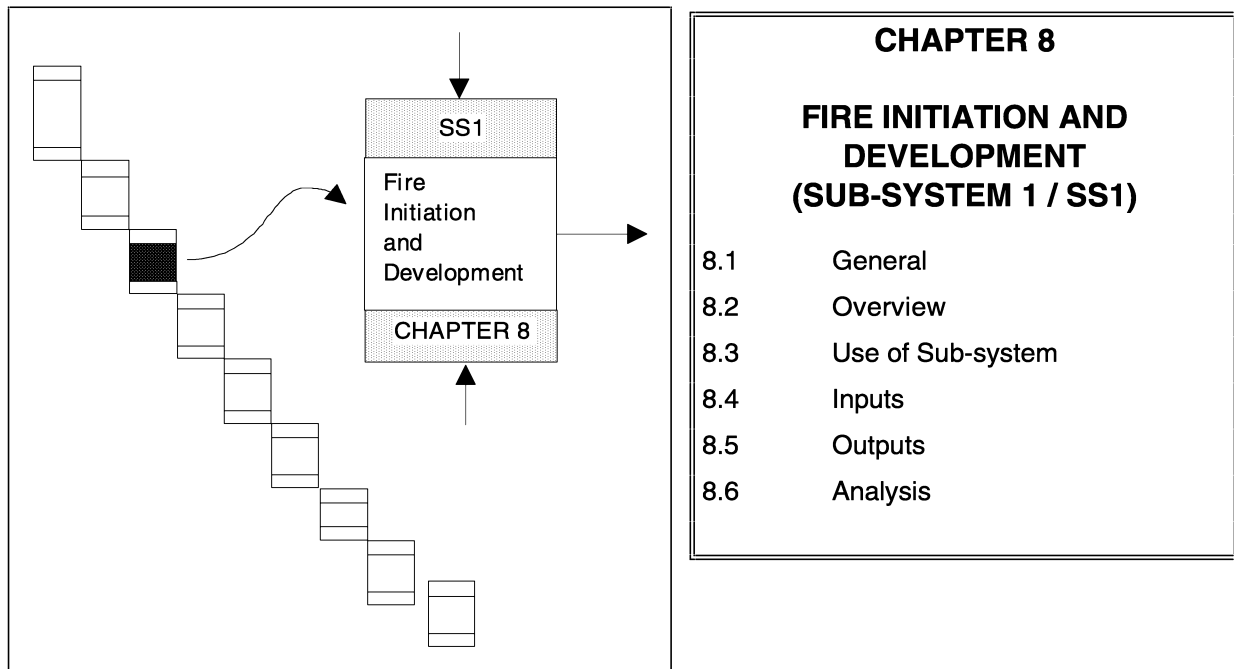

### 8.1 General

This Chapter provides methods on how to characterise fires in terms of:

- (a) heat release rate
- (b) toxic species yield
- (c) smoke yield
- (d) time to key events, particularly flashover

The Sub-system 1 is used to characterise fires in the enclosure of fire origin as well as enclosures to which the fire has subsequently spread.

The characteristic fire profile for any particular scenario is influenced by both building and occupancy characteristics and other events occurring during the fire, such as any fire suppression activity or creation of openings, e.g. failure to barriers (Sub-system 3).

The determination of a characteristic fire profile from ignition through to decay and final burnout is then used as input to other fire safety sub-systems, e.g. time of activation of detectors (Sub-system 4). In particular, the output of SS1 feeds into the development of untenable conditions in all enclosures (SS2) and the spread of fire and effect on structure (SS3).

### 8.2 Overview

#### 8.2.1 General

Fire may grow from ignition through a fully developed stage and finally to decay and eventually burnout.

The characteristic fire profile involves specification of the instantaneous heat release rate over the life of the fire. It also involves other fire parameters such as yield rate of smoke and toxic species, time to flashover, and flame height.



## Chapter 8 - Fire Initiation and Development

The initial approach to development of characteristic fire profiles must be based on the potential fire scenarios agreed through the FEDB process (see Chapter 4). Ignition sources, hazards and fuel loads along with building characteristics and decision on doors open/closed etc. all affect the initial approach to development of characteristic fire profiles.

The characteristic fire profile also influences and is influenced by particular fire events and other sub-systems. For example, Sub-system 1 provides input to activation time for detection and suppression systems (Sub-system 4). Similarly, events such as occupant fire fighting, activation of sprinkler systems and fire brigade fire fighting impact on the characteristic fire profile in a dynamic way. Equally, events such as window breakage can influence the final characteristic fire profile.

It needs to be understood that the characteristic fire profile developed for design purposes, based on the 'worst credible' or other scenarios, is unlikely to occur in practice. Actual fires are likely to be less severe and will not necessarily follow the design heat release rate curves used for design. It is hoped that the characteristic fire profiles are conservative but they are simple techniques developed for the purpose of design.

### **8.2.2 Fire initiation and Development**

For the purposes of design, the stages of fire initiation and development that should be considered are:

- (a) ignition
- (b) pre-flashover
- (c) flashover
- (d) fully developed fire
- (e) decay
- (f) burnout

These stages of a typical characteristic fire profile are illustrated in Figure 8.1

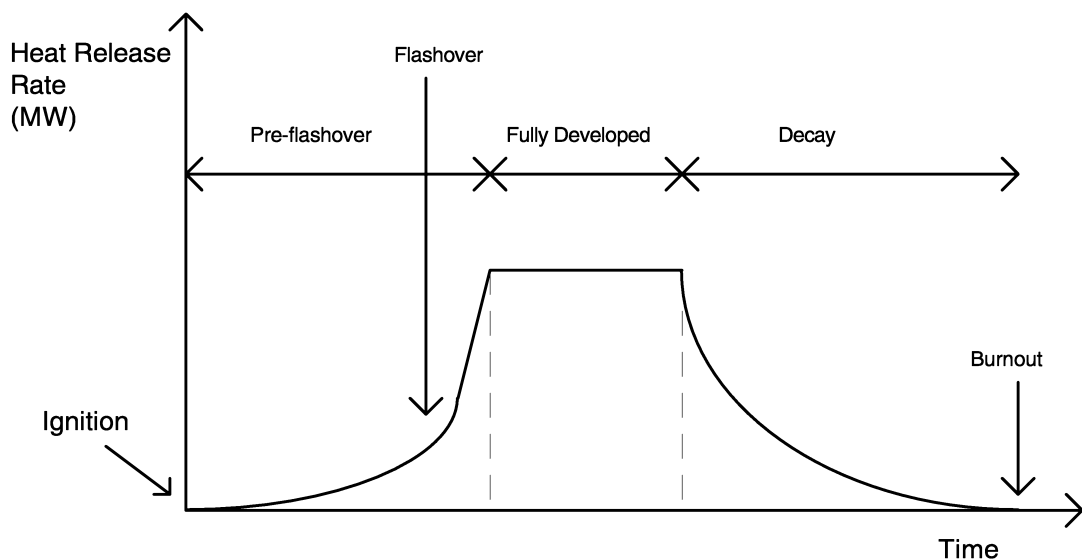

**Figure 8.1 Characteristic Fire Profile**

It should be noted that for any particular fire scenario, the characteristic fire profile may not include one or more of the stages because of lack of progression to the next stage, often through suppression activities. For example, if sprinklers operate it can be assumed the fire will not reach flashover.

### **8.2.3 Ignition**

Ignition requires the concurrence of 3 agents namely ignitable fuel, igniting heat and oxygen. Successful design for fire-safety should commence by addressing those agents in an attempt to prevent ignition. Management procedures aimed at isolating at least one of those agents are effective e.g. implementation of fire bans, non-smoking policies.

Consideration needs to be given to the processes and equipment as well as the nature of materials contained in the enclosure to be analysed, in order to determine whether potential for ignition exists.

There are at present no quantitative methods available for the prediction of potential for ignition. Qualitatively, however, consideration needs to be given to presence of potential ignition sources as in most instances, combustible fuels and oxygen are likely to be present. The presence of naked flames, sparks, temperatures capable of causing ignition (>200°C), oxidising materials need to be considered.

### **8.2.4 Pre-flashover**

#### **8.2.4.1 General**

Once ignition has occurred, fires may smoulder for a period and then break into flaming ignition. For some fuels the smouldering phase may be very short or non-existent, as in the case of flammable liquids.

The growth rate of fires during the smouldering and flaming phases are obviously quite different. Once flaming occurs, the spread of fires from the item first ignited to other items, including nearby fuel packages and wall linings, becomes a design consideration in any characteristic fire profile.

While this growth phase of the fire in the pre-flashover stage may be highly complex and erratic in actual fires, some simplifying assumptions are made for the purpose of design.

#### **8.2.4.2 Smouldering Fires**

A smouldering fire is generally a poorly ventilated fire producing very little heat but having the potential to fill a room with unburned combustible gases, toxic gases and smoke particles. If the room is then ventilated, very rapid ignition may occur. If the ignition gives rise to a deflagration this is described as backdraught.

The following factors affect the likelihood of onset of smouldering combustion:

- nature of the fuel;
- ventilation limitations
- strength of the ignition source

Smouldering fires can readily transform into flaming fires particularly when ventilation is increased.

## **Chapter 8 - Fire Initiation and Development**

The principal hazard associated with smouldering combustion is the release of carbon monoxide (CO) as a result of the incomplete combustion that takes place. The development of untenable conditions due to poor visibility is also a significant hazard that should be considered in the engineering analysis, particularly in residential fires.

There are at present no quantitative methods available for the prediction of potential for smouldering. Consideration needs to be given to the presence of materials prone to smouldering such as upholstered furniture, cellulosic materials particularly those treated with preservatives. Consideration also needs to be given to the presence of potential ignition sources capable of promoting smouldering such as cigarettes, hot objects, electrical sparks.

To predict the development of untenable conditions due to smouldering fires, see Chapter 9.

### **8.2.4.3 Flaming Fires**

#### **(a) Introduction**

To determine the rate of fire growth in a flaming fire in the pre-flashover stage, designers need to consider the item first ignited, the potential for spread and the influence of the enclosure. The FEDB process should provide the basis for fire growth for each scenario being quantified.

#### **(b) Established Burning**

The process of fire growth at the item that has first ignited involves an energy feedback whereby the heat released by the flames causes further pyrolysis. The new pyrolysis feeds further flaming, and so on for as long as fuel sources are sufficient. Flame spread is a process of successive ignition ahead of the flame front by energy fed back to the surface from the flames and the reaction zone. The process is generally controlled by the rate of heat release, ignitability and geometry, which affect the feedback.

Established burning occurs when the reaction is self-propagating without the presence of the ignition source.

After ignition, the likelihood of transition to an established burning phase needs to be considered. The following parameters are relevant in determining whether sufficient energy is likely to be fed back to the burning items to sustain the burning process:

- energy from the ignition source;
- the rate of heat release and flame characteristics from the ignited items;
- the geometry of the configuration; and
- energy losses particularly due to conduction

Established burning occurs when the fraction of energy fed back from the already burning surface exceeds critical flux required for ignition.

The onset of established burning is usually taken as the commencement of the fire-growth process for the purpose of the engineering calculations. Prior to established burning the fire can be considered to be in the incipient stage. The duration of this incipient stage is difficult to predict accurately and is usually not quantified in engineering calculations of development of untenable conditions. The length of the stage depends on the intensity of the ignition source and the nature of combustibles. Experiments involving particular

## **Chapter 8 - Fire Initiation and Development**

scenarios may provide a guidance on the duration of this incipient stage. From an engineering perspective the principal reason for needing to quantify this period relates to the operation of smoke detectors and manual suppression by occupants.

### **(c) Fire Spread**

Ignition of nearby items occur at the exposed surface by conduction, convection, radiation or a combination of the three.

Conduction takes place when two items are in contact and heat is transferred from the ignited item to the other.

Convection takes place when the flames or fire plume carry the heat to other items. Convection usually carries also burning embers, which cause piloted ignition (8.2.2. (a)).

Radiation of heat is usually the dominant mode of heat transfer that causes fire spread. The intensity of radiation received at a nearby combustible surface is dependent upon the size, temperature and emissivity of the flame, and its proximity to the receiving surface.

The key event in fire growth is the ignition of nearby items. For further information see Babrauskas - "Will the next item ignite" NIST (1981).

In determining the likelihood of fire spreading to nearby items the following factors need to be considered:

Spread by conduction:

- (i) temperature of the reaction zone;
- (ii) conductivity of the material;
- (iii) ignition temperature of the material

Spread by convection:

- (i) likelihood of flame impingement;
- (ii) temperature of flame or hot plume;
- (iii) effective heat-transfer coefficient; and
- (iv) ignitability of nearby items

Spread by radiation:

- (i) dimensions of the flame from the burning item;
- (ii) emissivity of the flames and absorptivity of combustible surfaces
- (iii) geometric view factor between the flames and nearby combustible surfaces;
- (iv) ignitability of nearby items and
- (v) the mode of ignition, that is, the availability of flames or sparks to cause piloted ignition.

### (d) Characteristic Fire Growth of flaming Fires

The parameters determining characteristic fire growth are:

- nature of combustibles;
- geometric arrangement of fuel;
- ignitability of fuel;
- rate of heat release characteristics;
- adequacy of ventilation

The growth time may be determined experimentally or from data based on carefully conducted experiments such as that given in NFPA 204M for stored goods. Experimental determination of growth time involves the burning of representative fuel configuration under an appropriate fire scenario in a large-scale calorimeter such as the furniture calorimeter. Experience has indicated that most fire safety analyses are sensitive to the choice of fire growth rate.

Typically, for design purposes, fires may be assumed to grow as t-squared fire as illustrated in Figure 8.2. However, this is not always the case and other heat release rate curves may be employed if justified.

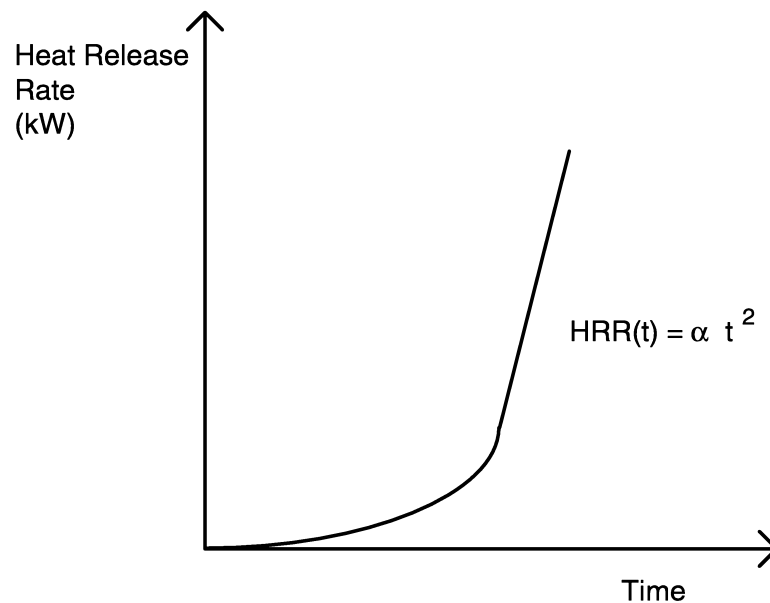

**Figure 8.2 Typical fire growth curve for design**

Fire growth time for simple configurations of fuel such as vertical and horizontal surfaces of relatively homogeneous fuel may be predicted from flame spread models. These models need to incorporate :

- Appropriate pyrolysis model for the fuel type
- realistic representation of radiation from the flames taking into account absorption and re radiation

## Chapter 8 - Fire Initiation and Development

- flow of gases and geometry
- reaction and energy release due to combustion in the gas phase.

### 8.2.5 Flashover

Flashover is characterised by the rapid transition from a localised fire to combustion of all exposed fuel surfaces within a compartment.

During the course of a fire a hot gas layer will generally form at ceiling level. The radiant heat transfer from this layer to combustibles below will accelerate the rate of fire spread and can lead to flashover and a fully developed fire.

When sustained flames from these combustibles reach the ceiling, and the rate of heat release is sufficient to give a hot gas layer temperature of 600°C, flashover should be assumed to occur. Conversely, if flames from the combustibles do not reach the ceiling or the temperature remains below 600°C, flashover should be assumed not to occur. Another criteria for flashover that is often used is 20 kW/m<sup>2</sup> at the floor.

Given that the fire is growing at a characteristic growth rate in an enclosure, the following parameters determine the likelihood and time of flashover;

- heat output from fire
- dimensions of fire
- temperature of the hot layer
- emissivity of the hot layer
- dimensions of the hot layer
- distance between fuel surface and the hot layer
- ignitability of the fuel
- enclosure openings
- enclosure ventilation

Flashover is an event that causes a modification to the heat release rate function. Section 8.6.5 indicates how the onset of the event can be predicted. Following flashover, the heat release rate of fires rapidly increase to the ventilation or fuel-bed controlled fire.

After flashover the rate of heat release will increase rapidly until it reaches the maximum value for the compartment.

To simplify design, the growth period between flashover and the maximum heat release rate is usually ignored and it may be assumed that when flashover occurs the rate of heat release instantaneously increases to the maximum value. This assumption is conservative and is illustrated in Figure 8.3.

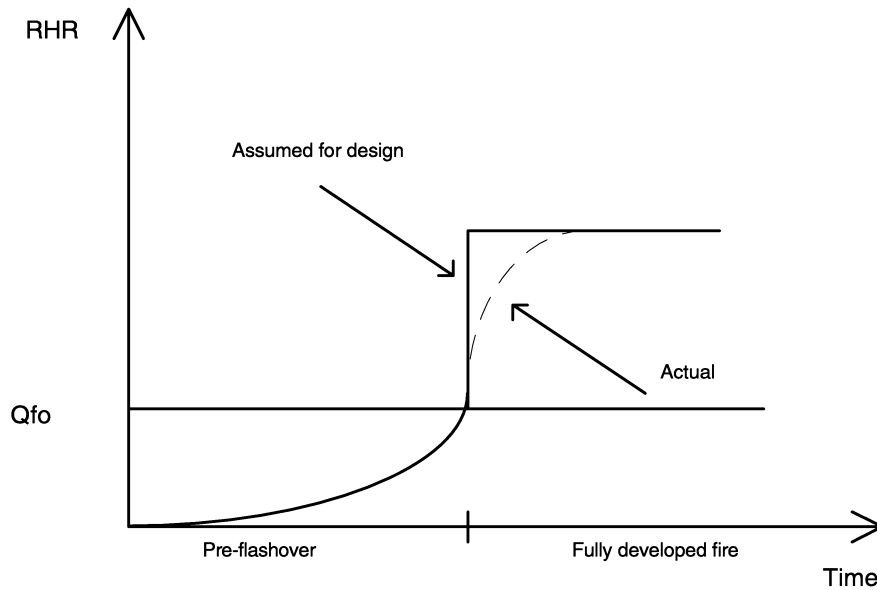

**Figure 8.3 Flashover transition**

### 8.2.6 Fully developed fire

During the fully-developed fire, the maximum rate of heat release may be controlled by either the available ventilation or the quantity and nature of the fuel. The rate of heat release for a fully-developed fire is calculated as the lower between those of the ventilation-controlled fire and the fuel-bed- controlled fire.

The energy release during a fully-developed fire is dependent upon the following parameters for a ventilation-controlled fire that has reached flashover:

- available ventilation including changes with time, e.g. due to glass breakages;
- shape and location of ventilation openings;
- thermal characteristics of enclosure;
- nature of fuel, particularly pyrolysis temperature.

The impact of such a fully-developed fire on the compartment boundaries and structural members are dependent upon temperature of the hot gases and the flow of unburned fuel from the compartment.

The rate of heat release from a fully-developed fire that is limited by the fuel bed is dependent upon -

- nature of the fuel;
- surface area of exposure; and
- dimensions and thermal characteristics of compartment

## Chapter 8 - Fire Initiation and Development

During the fully developed fire, the maximum rate of heat release may be controlled by either:

- the available ventilation;
- the quantity and nature of the fuel

The rate of heat release for both ventilation-controlled and fuel-bed-controlled regimes should be calculated and the lower value, i.e. the dominant regime, taken as representing the fully developed fire.

### (a) Ventilation-Controlled Fires

The available ventilation imposes an upper limit on the rate of burning. If the available ventilation is restricted the fire may not reach the flashover stage. Where flashover does occur the rate of heat release will rise to the maximum possible with the available ventilation (see figure 8.4).

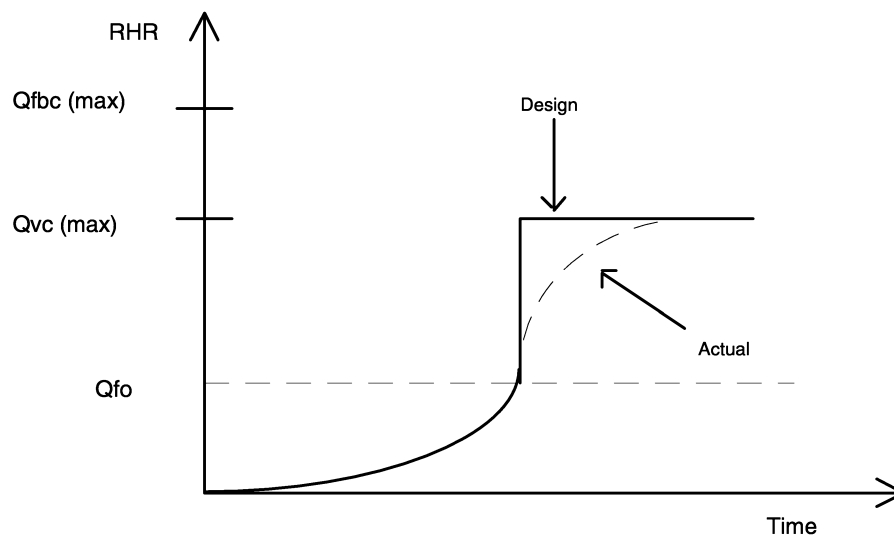

Note:  $Q_{fbc(max)}$  is the rate of heat release under fuel-bed-controlled conditions;  
 $Q_{vc(max)}$  is the rate of heat release under ventilation controlled condition  
 $Q_{fo}$  is the rate of heat release at flashover

**Figure 8.4 Fully developed fire (ventilation controlled)**

### (b) Fuel-bed Controlled Fires

In a fuel-bed-controlled fire the combustibles are able to burn freely and the rate of heat release is controlled by the amount, type and surface area of the burning items. With small amount of fuels or slow-burning materials the rate of heat release may be too low to produce flashover even when all the items are burning. Where flashover does occur the rate of heat release will eventually rise to the maximum free burning value (see figure 8.5).



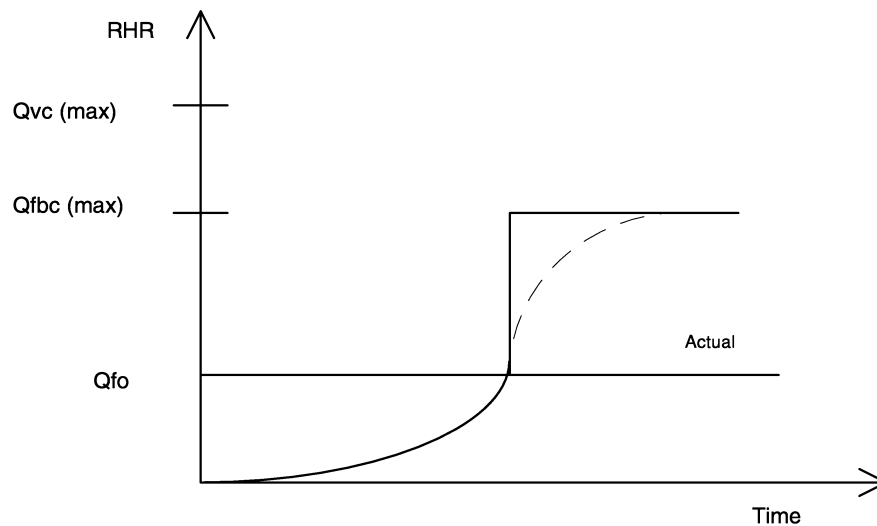

Note:  $Q_{fbc(max)}$  is the rate of heat release under fuel-bed-controlled conditions;  
 $Q_{vc(max)}$  is the rate of heat release under ventilation controlled condition  
 $Q_{fo}$  is the rate of heat release at flashover

**Figure 8.5 Fully developed fire (fuel-bed controlled)**

### (c) Change of Ventilation

During the course of the fire the ventilation may change for a variety of reasons including windows breaking, fire service intervention, or the operation of air handling or smoke extraction systems. It may be necessary to estimate the time at which changes in the available ventilation occur as this may influence the rate of fire growth and its severity. For the purposes of design, a characteristic fire profile may have to be assumed, and then calculations show window breakage or other events are possible, then assumptions on available ventilation must be altered and the characteristic fire profile appropriately modified.

### 8.2.7 Decay

When most of the fuel in a compartment has been consumed or the fire fails to spread to adjoining items, the rate of burning decreases generally due to the build-up of char. Decay of the fire may be due to either exhaustion of the fuel or fire suppression activities. In the case of fuel exhaustion the following parameters govern the onset of decay:

- amount of fuel;
- characteristics of fuel particularly charring; and
- the dispersion of fuel leading to localised reversion to a fuel-bed-controlled fire

The onset of decay has not yet been well defined and further research is required for accurate prediction. For design purposes it may be assumed that the rate of heat release remains constant until 80% of the fuel has been consumed and an empirical relationship based upon fraction of fuel consumed is often used to model the decay.

### 8.2.8 Interventions

#### 8.2.8.1 Modification of Characteristic Fire Profile

The initial characteristic fire profile is subsequently modified by the action of other sub-systems. The most significant modifications occur upon the activation of fire suppression systems and fire fighting activities. It is also possible that other sub-systems have impact upon the fire and these need to be considered here.

The characteristic fire profile can be considered as being defined over ranges in time. An event may cause a change to the profile at the time of occurrence of the event (plus any delay times).

For the purposes of design the effects of suppression by building sub-systems or the fire brigade may be confined to the three generic possibilities outlined below and illustrated in figure 8.6:

- (1) **fire extinguished** (the application of the extinguishing agent reduces the rate of heat release from the fire effectively to zero);
- (2) **fire controlled** to steady state (the application of the extinguishing agent stops the increase in the rate of heat release from the fire, which then continues to burn at a constant rate of heat release);
- (3) **uncontrolled fire, system over-run** (the application of the extinguishing agent fails to stop the rate of heat release increasing). The agent will fail if the rate of heat release at application  $Q_{sup}$  exceeds the maximum rate of heat release which the system can control or extinguish, denoted by  $Q_{control}$ .

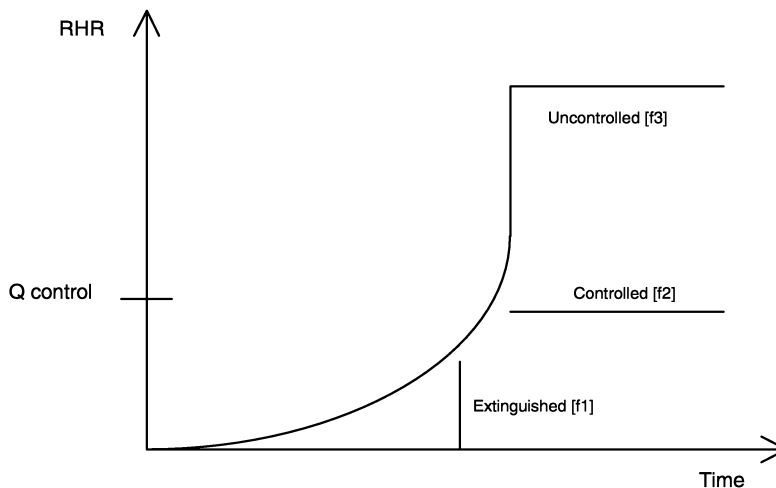

Figure 8.6 Effect of suppression system or fire service

#### 8.2.8.2 Intervention by Automatic Suppression Systems

Automatic suppression equipment may operate at any time during the fire. However, it would normally be expected to operate in the pre-flashover stage if it is to be effective. If the suppression equipment has not operated before flashover, it may be assumed for design purposes that there is no effective operation and the rate of heat release will not be modified by the suppression equipment.

### **8.2.8.3 Intervention by Fire Service**

The fire service may intervene at any time during the development of the fire, but it should be assumed that they will be able to control the fire only if it is within the capabilities of the appliances in attendance. However, when carrying out a level 2 study against life safety objectives the effects of fire service intervention on fire growth should be discounted.

### **8.2.8.4 Intervention by occupants**

Fire intervention by occupants involves the use of hand-held devices such as extinguishers, blankets, hose reels or ad-hoc means. For a Level 2 evaluation it is recommended to adopt any of the following:

- (a) Assume no intervention by occupants; or
- (b) Apply statistical information to determine the most likely locations of fires related to the type of building being assessed.

It must be remembered that fires recorded in Australian Statistics did involve fire-brigade attendance unless otherwise indicated, and, therefore it can be assumed that occupant suppression has been ineffective. However, the statistics could, indirectly, indicate the effectiveness of occupant intervention. For example, if a statistical report on location of fire incidents for a certain type of industrial building indicates a relatively very low percentage of fires recorded in the staff room, which may imply that suppression by occupants has been effective, the Designer would not need to consider such a fire scenario.

A Level 3 evaluation requires the use of the probability of occupants being effective in extinguishing a fire at its early stage. Data on this probability is limited to incident reports recorded for those premises where every occurrence (e.g. smouldering waste-paper basket suppressed by glass of water) is recorded. The importance of this data in providing an overall picture cannot be overemphasised.

## **8.3 Use of sub-system**

The flowchart in Fig 8.7 illustrates the procedure to be followed to specify the characteristic fire profile in an enclosure as a function of time. The procedure is indicative and the impact of other sub-systems or events need to be considered. The procedure indicates the fire growth and decay process that needs to be considered for each fire scenario. The probability of occurrence of the particular scenario and characteristic fire profile can be determined from the likelihood of the ignition occurring giving rise to the scenario.

## **8.4 Inputs**

### **8.4.1 Fire Scenario**

The fire scenario to be analysed is identified and described quantitatively during the FEDB process. During this process where the fire starts and the materials involved in the ignition and fire growth are specified. Assumptions are made with regard to the arrangement of the fuel to represent the fire scenario of interest. Assumptions are also made about the likelihood of window breakage, suppression systems, etc. that have to be evaluated and incorporated into the analysis if appropriate.

The need to analyse smouldering fires should be considered during the FEDB stage.

## Chapter 8 - Fire Initiation and Development

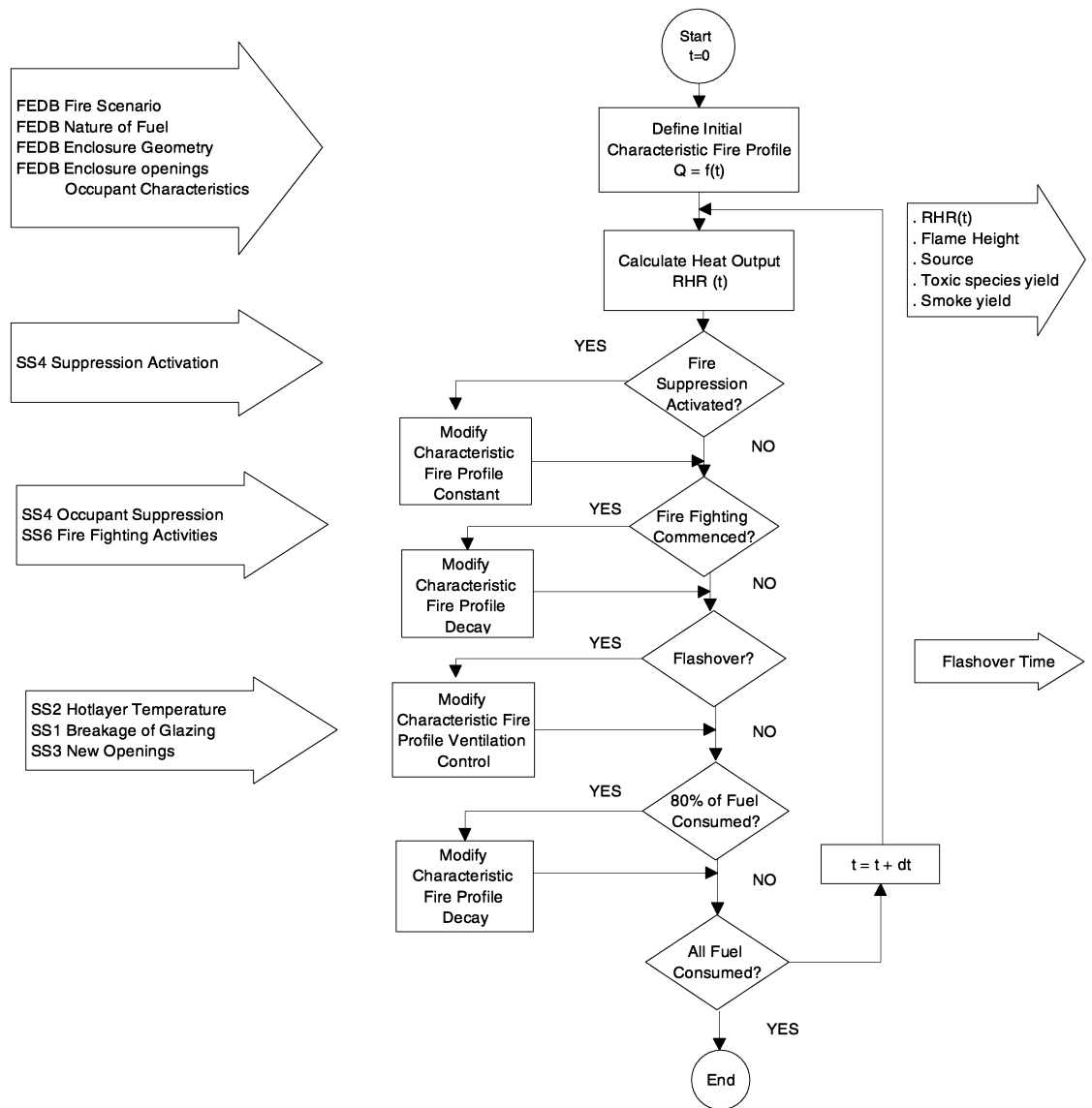

**Figure 8.7** The procedure to be followed to specify the characteristic fire profile in an enclosure as a function of time

### 8.4.2 Occupancy characteristics

Input is required regarding occupancy characteristics that impact on the fire. Parameters such as wall linings and ambient conditions may impact on the rate of fire development. The principal input from the FEDB is regarding specific arrangements of fuel such as fixed seating which may have major impact on the fire growth process.

The occupancy characteristics are principally used in this sub-system to evaluate the likelihood of fuel-bed controlled fires and to determine the nature of combustibles which is relevant in the determination of the yield of toxic species.

Occupancy characteristics also impact on the likelihood of smouldering fires.

### **8.4.3 Enclosure geometry**

Enclosure geometry has a significant impact on the occurrence of flashover. The dimensions and location of openings may limit the oxygen that is available for combustion and the height and temperature of the hot layer which in turn impacts on the time of flashover. A re-entrant alcove may act as a small room leading to localised flashover.

The enclosure geometry in this sub-system is principally used in the prediction of flashover and during ventilation controlled burning.

### **8.4.4 Activation of suppression**

The time of activation and effectiveness of fire suppression system is required in order to modify the heat release function.

### **8.4.5 Fire fighting activity**

The time of commencement and effectiveness of fire fighting activities is required in order to modify the heat release function.

### **8.4.6 Occupant Suppression**

The time of commencement and effectiveness of manual fire suppression by occupants is required to modify the heat release function.

### **8.4.7 Hot Layer temperature**

The hot layer temperature in the enclosure is used to predict the onset of flashover. This parameter is obtained from Sub-system 2.

### **8.4.8 Creation of new openings**

The creation of new openings by the fire or other activities impact on both the time of flashover and on the ventilation-controlled burning rate.

## **8.5 Outputs**

### **8.5.1 Instantaneous heat release rate**

This sub-system provides characterisation of fires in enclosure in terms of the instantaneous heat release rate. This is calculated as the characteristic fire profile that is progressively modified during the course of the fire.

### **8.5.2 Toxic species yield**

The fire is also characterised by a source concentration of toxic species. Generally only carbon monoxide production is specifically tracked but other species may be relevant depending on the nature of the fuel and the depth of the analysis undertaken.

### **8.5.3 Smoke yield**

This sub-system provides information on the source concentration of smoke. This is subsequently used in SS2 to evaluate the dilution and transport of smoke in order to calculate the smoke density at locations of interest.

### **8.5.4 Flashover time**

The time of flashover is output from this sub-system. It is based upon either hot layer temperature data or empirical expressions in the case of small compartments with well defined openings.

### **8.5.5 Flame Height**

The height of flames is an output required for some flame spread / ignition calculations and for the actuation of detectors.

## **8.6 Analysis**

### **8.6.1 Ignition**

With the exception of certain burning metals, ignition takes place on the gases that are released by solids, or liquids. The release of gases, is known as pyrolysis and its rate increases with the energy input into the material.

The following modes of ignition are possible:

Piloted ignition takes place when the pyrolysis gases are ignited by a localised hot object or energy source such as a flame or spark.

Non-piloted ignition takes place when the temperature of the pyrolysis gases is such that the energy produced by the exothermic reaction of pyrolysis is sufficient to ignite the volatile mixture of oxygen and pyrolysis products.

Spontaneous ignition takes place when the oxidation reaction within certain materials produces sufficient energy to raise the temperature above the ignition point.

Ignition of flammable liquids may occur at temperatures above the flash point in the presence of naked flame or sparks of sufficient energy. The evaporation rate of liquids above the flash point is sufficient to cause a flammable mixture above the lower flammability limit. Flashpoint may be determined by test using the Pensky-Martens apparatus.

Having established that there is a potential for ignition, one needs to consider the likelihood of ignition occurring. In this process, consideration needs to be given to the following parameters:

- flashpoint of any flammable liquids;
- available ignition energy;
- flammability limit of any combustible vapours;
- ignitability characteristics of materials that are in close proximity to the ignition source;
- critical temperature of materials

## **Chapter 8 - Fire Initiation and Development**

The time of ignition may be determined by means of ignitability tests to AS 1530.5, which provides data on time to ignite under various impressed heat flux conditions. If the intensity of heat flux from the ignition source can be determined, then the results of the tests can be used to predict ignition times. If the exposed heat flux condition varies with time, approximations based upon integration of the energy received with time may be used.

Some typical figures for ignition of solids are given in Table 8.1. Sources such as the SFPE Handbook (1988) and Drysdale (1985) provide details of the theory of ignition of both the liquids and solids and suitable data. These data may be used to examine the ignition of the first item and the ignition of subsequent fuel packages.

**Table 8.1 Criteria for ignition**

Material	Critical Radiant Heat Flux (KW/m <sup>2</sup> )		Critical Surface Temperature (C°)	
	Pilot	Spontaneous	Pilot	Spontaneous
'Wood'	12	28	350	600
Chipboard	28, 18	--	--	--
Hardboard	27	--	--	--
PMMA 'Perspex'	21	--	270	--
Flexible PUF	16	--	270	--
Polyoxymethylene	17	--	--	--
Polymethylene	12	--	--	--
Polymethylene/42% CI	22	--	--	--

For design purposes, a figure of 10 or 20 KW/m<sup>2</sup> is often used as the value for radiation required for ignition of a broad range of materials. However Babrauskas has developed a little more sophisticated analysis of the mechanism of fire spread through ignition of the second and subsequent items by flame contact or radiation from flames.

For the case of direct flame contact, the ignition time of the second item can be assumed to be the time at which the contact occurs. (This assumption is conservative since time is required to pyrolyze fuel and heat gases produced to their ignition temperature). For radiant ignition, a crude assumption is that prior to flashover, the radiation from the upper layer and the room surfaces are negligible. Thus, the radiant energy transfer to the surface of the second item all comes from the flame above the first item. Based on this crude assumption, Babrauskas developed a procedure for estimating the ignition of the second item.

In this procedure, the radiant flux necessary to ignite an item is assumed to be 10 kW/m<sup>2</sup> for easily ignited items such as thin curtains or loose newsprint, 20 kW/m<sup>2</sup> for "normal" items such as upholstered furniture, or 40 kW/m<sup>2</sup> for difficult to ignite items such as wood of 5 cm or greater thickness. The mass loss rate of the burning item necessary to produce these ignition flux at various separation distances between items is presented in Figure 8.8. Thus the time to ignition of the second item is the time at which the mass loss rate of the burning object first reaches the value necessary to produce the required flux at the distance between the objects.

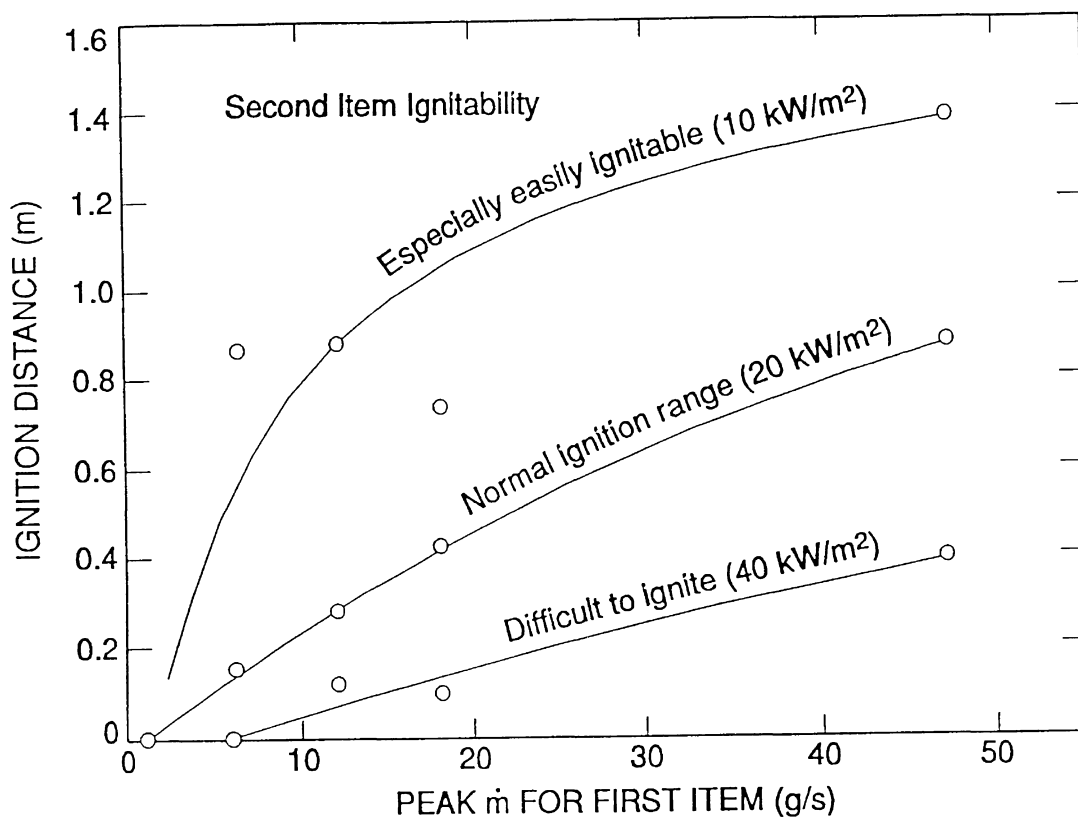

**Figure 8.8 Relationship between peak mass loss rate and ignition distance for various ignitability levels**

A more detailed analysis of radiative ignition is presented in Appendix 10A of these Guidelines.

### 8.6.2 Pre-flashover

#### 8.6.2.1 General

The rate of fire growth in the pre-flashover phase of a fire is one of the major determinants of the performance of a fire safety design. It is therefore critical that fire engineers investigate carefully the possible fire growth rates.

Designers are encouraged to analyse more than one fire scenario, particularly choosing two or more scenarios that have different fire growth rates. This forms some part of the sensitivity analysis and helps designers identify the 'worst credible' scenario, which may not necessarily be that scenario with the highest fire growth rate.

There is an absence of good data on growth rates, particularly in occupancies other than residential. Engineers should consult the SFPE Handbook (Babrauskas: 1995: 3-1) and other sources to address this crucial design issue.



## Chapter 8 - Fire Initiation and Development

The methods of determining the rate of fire growth are given in order of preference:

- i. carefully designed full scale experiments
- ii. furniture calorimeter data
- iii. statistical data / fire incidents
- iv.  $t^2$  fires

### 8.6.2.2 T-Squared Fires

The development of a fire can be considered as a continuous fire growth curve in terms of the heat output of the fire.

The microscopic approach traces the fire development from the point of first contact of the ignition source and a fuel. It then follows the fire development for a specific combination of fuel, ignition source and surroundings. Although this approach is most precise, it suffers from the difficulty of predicting the multitude of possible fire scenarios.

In the macroscopic view, the fire is considered to grow and interact with its surroundings, while the detailed mechanism of fire growth is not considered. This approach enables the establishment of a worst-case fire-growth curve to be based upon the general nature of the combustibles.

Where relevant experimental data and or statistical information is not available pre-flashover fires can be characterised by a quadratic function [NFPA 204M] of the form

$$\dot{Q} = \alpha \cdot t^2 \quad \text{or} \quad Q = (t/k)^2 \quad (8.1)$$

where

$\dot{Q}$  is the rate of heat release in megawatts

$t$  is the time in seconds from the 'effective ignition time'

$\alpha$  is the fire growth parameter expressed in MW/sec<sup>2</sup>

$k$  is the characteristic time of growth to 1MW expressed in seconds

Many natural fires follow this law in the initial growth phase, the 'growth time' being indicative of the rate of burning and spread. Table 4.2 from NFPA 204M standard provides the values of the characteristic growth parameter  $\alpha$  for a range of common materials in a warehouse situation.

NFPA standard 72E categorises  $t^2$  fires into four categories with the following growth times that may be used as the basis of design:

Where specific fuel items cannot be identified then the fire growth parameters outlined above may be appropriate for design purposes.

However, in some circumstances actual fuel items likely to ignite are known or have been identified in the scenario development as part of the FEDB process.

## Chapter 8 - Fire Initiation and Development

**Table 8.2 Fire Growth Parameters**

Fire Category	Typical materials	Fire Growth Parameter $\alpha$ (MW/sec <sup>2</sup> )	Growth Time
Ultrafast	Some pool fire, faster burning upholstered furniture. Lightweight drapes	$1.77 \times 10^{-4}$	75 s
Fast	Full mail bags, plastic foam, stacked timber pallets	$4.44 \times 10^{-5}$	150 s
Medium	Cotton/polyester spring mattress.	$1.11 \times 10^{-5}$	300 s
Slow	----	$2.77 \times 10^{-6}$	600 s

### **8.6.2.3 Calorimeter Data**

Results from furniture calorimeter tests may be used as a direct source of heat release data for fire models provided that consideration is given to the limitations. Most information on burning rates for single items has been reported under free burning conditions, i.e. it has been collected from items burning in a large enclosure. These data may give rise to errors because:

- (a) free burning conditions do not take account of radiative feedback from a hot smoky layer or enclosure surfaces;
- (b) the fire may be restricted by the supply of oxygen.

### **8.6.2.4 Occupancy Data**

Some fire engineering guidance documents give specific fire growth parameters for particular occupancies eg 'fast' rates in shops 'medium' in offices. This is too simplistic an approach because fire load (as reflected in occupancy) is only one factor in early fire growth. More important are factors such as:

- arrangement of combustibles
- degree of vertical spread possible
- available ventilation
- closeness of walls as re-radiators
- ceiling height for radiation feedback

Thus, in one situation with lightweight combustibles stacked high in a well ventilated, low ceiling shop the rate of fire growth might be judged 'fast'. In another case, the same combustibles spread more horizontally in a shop with a high ceiling may be judged to grow at a 'medium' or even 'low' rate.

This highlights the important of proper scenario development in fire engineering.

### 8.6.2.5 Area Basis for Design

If the likely rate of heat output per unit area can be established for the particular use of the building, the rate of heat release may be estimated from the fire area (or vice versa) as given by the equation:

$$Q = Q'' \cdot A_{\text{fire}} \quad (8.2)$$

where

Q is the heat output of the total fire area (in kW)

Q'' is the heat output per unit area of fire (in kW m<sup>-2</sup>)

A<sub>fire</sub> is the area of fire (in m<sup>2</sup>)

For design purposes the heat release rates given in Table 8.3 may be used in the absence of more specific data..

**Table 8.3 Maximum Heat Release Rates**

Building Use	Heat Release Rate (kWm <sup>-2</sup> )
Retail	500
Offices	250

### 8.6.2.6 Calculations from First Principles

Once the rate of heat release of the item first ignited has been determined from calorimeter data (see 8.6.2.2) an analysis should be performed to ascertain if the fire is likely to spread to neighbouring items. This can be accomplished by considering the radiant heat transfer from the flames to adjacent fuel items. The radiant flux incident on the adjacent packages should be compared with critical levels to determine if secondary ignition (fire spread) is likely.

### 8.6.2.7 Source concentration of toxic species

The source concentration of toxic species is determined by considering the yield of toxic species from an analysis of the combustion reaction or experimental data relating to the nature of combustibles. The principal toxic species is carbon monoxide in most fires and analysis can generally be restricted to this species unless the materials involved are atypical or involve products containing fluorine or other supertoxicants.

The concentration of carbon monoxide can be estimated from the carbon monoxide yield factor and the equation:

$$Conc_{CO} = \frac{Y_{CO} m_f}{V_t} \quad (8.3)$$

## Chapter 8 - Fire Initiation and Development

where

$Conc_{CO}$  is the concentration of carbon monoxide (in  $kg\ m^{-3}$ );

$Y_{CO}$  is the carbon monoxide yield factor (in g/g);

$V_t$  is the volume of smoke (in  $m^3$ );

$m_f$  is the mass of fuel burnt (in kg).

Values of  $Y_{CO}$  may be obtained from table 8.4.

The concentration in parts per million (ppm) at 20 °C may be obtained from :

$$CO(ppm) = 0.858 \times 10^6 Conc_{CO} \quad (8.4)$$

or

$$CO(ppm) = \frac{0.858 \times 10^6 Y_{CO} m_f}{V_t} \quad (8.5)$$

**Table 8. 4. Typical product yield for well ventilated flaming combustion<sup>+</sup>**

Material	Carbon monoxide mass conversion rate ( $Y_{CO}$ ) kg/kg	Mass optical density ( $D_m$ ) $m^2\ g^{-1}$
Timber	0.004	0.04
Polyvinyl chloride (PVC)	0.063	0.40
Polyurethane (flexible)	0.042	0.34
Polyurethane (rigid)	0.051	0.30
Polystyrene	0.060	1.0
Polypropylene	0.024	0.24
Generic building contents *	0.013	0.30

\* The data for the generic building contents may be applied to residential, office and retail premises where there is a typical mixture of combustible contents.

**<sup>+</sup> Poorly ventilated fires may produce carbon monoxide yields many times higher than well ventilated fires.**

### 8.6.2.8 Smoke Yield

## Chapter 8 - Fire Initiation and Development

The mass production rate of smoke ( $\dot{M}_s$ ) can be estimated by consideration of smoke mass conversion factor which represents the fraction of the burning material that is converted to smoke.

The production rate of smoke is given by :-

$$\dot{M}_s = E \dot{Q} / H_c X_c \text{ (kg/s)} \quad (8.6)$$

Where  $E$  is the smoke mass conversion factor (kg/kg)

(Table 8.5 provides typical range for this factor)

$\dot{Q}$  is the heat release rate of the fire (MW)

$H_c$  is the heat of combustion of the fuel (MJ/kg)

$X_c$  is combustion efficiency (no units)

**Table 8.5 Typical Ranges of Smoke Mass Conversion Factors**

Material	Smoke mass conversion factor $E$ (kg/kg)	
	Flaming	Non-flaming
Cellulosic	<0.01 - 0.025	0.01 - 0.17
Plastics	<0.01 - 0.17	<0.01 - 0.19

The mass concentration of the smoke ( $C_m$ ) at the source may be obtained by dividing the mass production rate of smoke ( $\dot{M}_s$ ) by the volumetric flow rate of fire effluents ( $\dot{V}_f$  (m<sup>3</sup>/s))

$$C_m = \dot{M}_s / \dot{V}_f \text{ (kg/m}^3\text{)} \quad (8.7)$$

The relationship between measured optical density per meter and mass concentration in mg/m<sup>3</sup> is shown in Figure 8.9. Saeder & Einhorn(1977) performed experiments with the NBS Smoke Density Chamber showing roughly similar correlations for a number of different smouldering or flaming materials.

The ratio of optical density per meter to mass concentration is termed particulate optical density (POD) and is shown to be a relatively constant property for each of the two modes of burning. It thus appears that for white light, POD for flaming combustion is 3400 kg/m<sup>3</sup> and for non-flaming combustion 1900 kg/m<sup>3</sup> (Holmstedt et al :1987)

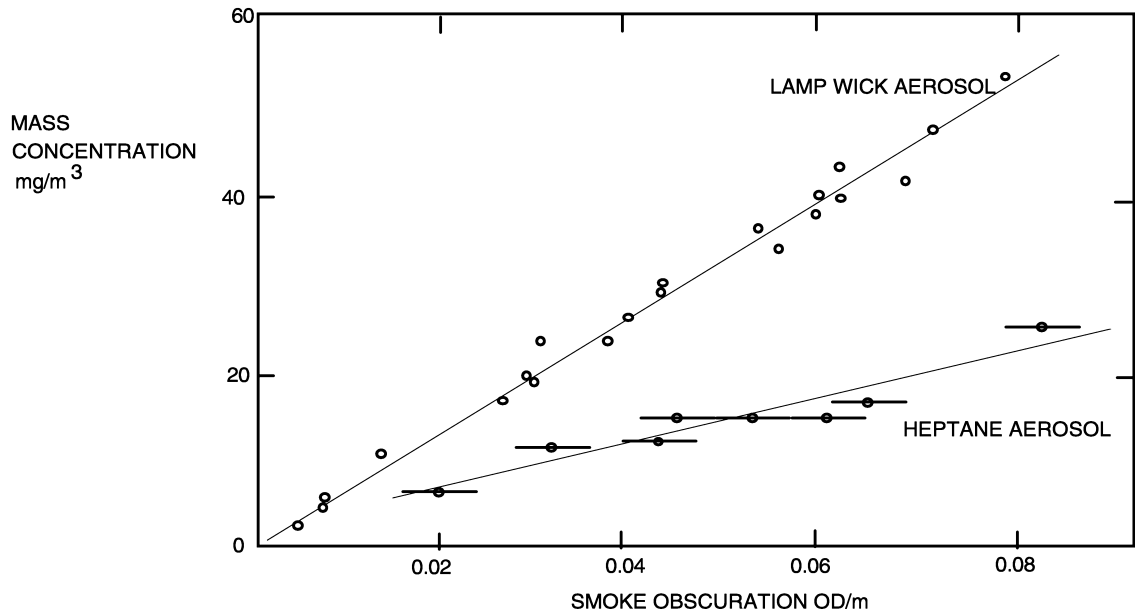

**Fig 8.9 Mass concentration versus smoke obscuration (optical density per metre) in UL 217 Standard Evaluation Chamber (Lee & Mulholland: 1977)**

Thus:

$$OD = 3400C_m(m^{-1}) \text{ for flaming combustion; and}$$

$$OD = 1900C_m(m^{-1}) \text{ for non-flaming combustion.}$$

### 8.6.2.9 Rate of Growth of Smouldering Fires

For smouldering fires, the model developed by Quintiere is commonly used. This model describes the pyrolysis rate by the expression:

$$dm/dt = (0.10 \text{ g min}^{-2})t + (0.0185 \text{ g min}^{-3})t^2 \text{ for } 0 < t < 60 \text{ min} \quad (8.8a)$$

$$dm/dt = 73 \text{ g min}^{-1} \text{ for } 60 < t < 120 \text{ min} \quad (8.8b)$$

The Carbon Monoxide production rate may be determined from the mass fraction of CO production:

$$G = m_{CO} / m \quad (8.9)$$

Where

$m_{CO}$  is the mass of CO produced and

$m$  is the total mass of pyrolysis products

The energy release rate may be determined from the heat of reaction of the smouldering process.

$$H_r = m_{\text{ox}} H_{\text{ox}} / m \quad (8.10)$$

Where

$m_{\text{ox}}$  is the mass of oxygen consumed and

$H_{\text{ox}}$  is the heat of combustion per unit mass of oxygen consumed (taken as  $13 \text{ kJg}^{-1}$ )

The parameters for a smouldering upholstered chair are:

$$G = 0.11$$

$$H_r = 1.5 \text{ MJ/kg}$$

If flaming ignition occurs as a result of an increase in ventilation (e.g. by opening a door) the procedures for flaming fires may then be utilised. The change from a smouldering to a flaming fire may be such as to give rise to a relatively slow growing fire or may be an explosive transition (backdraught) to the fully developed condition.

### 8.6.3 Flashover

Simple correlations as explained in (a) and (b) below have been developed to predict the onset of flashover. These correlations must be viewed as approximations to the more definitive determinations based upon calculations of ignition resulting from the heat flux to the fuel surface. Prediction based upon hot layer temperatures is generally preferred as it has a more direct relationship to radiation from the hot layer that causes the flashover phenomena.

#### (a) Hot Layer Flashover Prediction:

When sustained flames from burning contents reach the ceiling, and the rate of heat release is sufficient to give a hot gas layer temperature of  $600^\circ\text{C}$ , flashover should be assumed to occur. Conversely, if flames from the combustibles do not reach the ceiling or the temperature remains below  $600^\circ\text{C}$ , flashover should be assumed not to occur. Zone or Field models described in Section 9 may be used to estimate the hot-layer temperature.

#### (b) Flashover Correlation:

Thomas has developed an empirical correlation for the energy release rate required to cause flashover in a compartment. The correlation was developed based on small compartments and its application to large or high compartments is not appropriate. The energy release rate for flashover is given by:

$$\dot{Q}_f = 7.8 A_{\text{encl}} + 378 A_v \sqrt{h_v} \quad (8.11)$$

where

$A_{\text{encl}}$  is given by:

$$A_{\text{encl}} = 2 [LW + (L + W)H_{\text{encl}}] - A_v \quad (8.12)$$

and

$L$  is length of enclosure

## Chapter 8 - Fire Initiation and Development

- W is width of enclosure
- $A_v$  is area of ventilation openings
- $h_v$  is the effective height of the opening

The time of flashover shall be taken to be when the hot layer temperature in the enclosure reaches 600° C or when the rate of heat released from the fire is equal to that required to cause flashover. Another criteria often used is when the radiation at the floor from the hot layer reaches 20 kW/m<sup>2</sup>.

### **8.6.4 Fully Developed Fires**

#### **8.6.4.1 General**

Fully developed fires will be controlled by the available ventilation or the fuel available. The fire engineer must calculate the heat release rate at ventilation control and fuel control, and use the lesser of two figures as the peak heat release rate for the fully developed fire.

#### **8.6.4.2 Ventilation controlled fire**

The ventilation-controlled rate of burning for cellulosic fuels in a compartment is best determined from the air flowing into the compartment. The air inflow can be approximated to be

$$m_{\text{air}} = 0.52 A_v \sqrt{h_v} \text{ kg/s} \quad (8.13)$$

where

- $m_{\text{air}}$  is mass flow of air into compartment
- $A_v$  is area of vent
- $h_v$  is height of vent

or may be more accurately predicted by fire models that provide accurate indication of smoke flowing from an enclosure.

The mass rate of fuel burning may then be estimated from the combustion reaction. The stoichiometric ratio is approximately 5.7 for cellulosic fuels. However under ventilation-limited conditions the effective fuel/air ratio is approximately 1.3 times the stoichiometric ratio (Babrauskas 1981). This yields an approximate expression for the rate of fuel consumed  $m_{\text{vf}}$  :

$$m_{\text{vf}} = 0.12 A_v \sqrt{h_v} \text{ kg/s} \quad (8.14)$$

This may be converted to heat release rate by multiplying by the effective heat of combustion. For cellulosic fuels burnt under ventilation controlled conditions, the effective heat of combustion may be taken as 18 MJ/kg. Hence for a ventilation-controlled cellulosic fire the heat release rate  $Q_v$  may be approximated by :

$$\dot{Q}_v = 1.26 A_v \sqrt{h_v} \text{ MW} \quad (8.15)$$



### 8.6.4.3 Fuel controlled fire

The burning rate of fuel bed controlled fires is difficult to predict. It is to a large extent dependent upon the nature and geometric arrangement of the fuel. Based on work conducted with wood crib fires, the mass loss rate over the area of the fire can be estimated by the following expression:

$$m_{pf} = 0.0012 M_o (m/M_o)^{1/2} \text{ kg/s} \quad (\text{or } Q_{pf} = 0.0158 M_o (m/M_o)^{1/2} \text{ MW}) \quad (8.16)$$

where

$m_{pf}$  = fuel control pyrolysis rate (kg/s)

$M_o$  = total initial mass (kg) over burning area

$m$  = mass remaining (kg) at time  $t$  seconds over burning area

This equation may be used to fully define the development of the fire as it spreads at the fully developed stage if the area of the burning area is known with time. For design purposes, the entire area of the enclosure may be assumed to be fully involved following flashover and  $m$  may be evaluated at the point of flashover to determine the peak value of  $m_{pf}$ .

In a large space, the fire may not reach flashover and therefore not all of the fuel in the space is ignited at the fully developed stage. In order to reasonably predict the effective mass loss rate, the area over which the fuel has ignited must be estimated to determine  $m$  and  $M_o$ .

The above relationship also takes into account the decay characteristics because  $m_{pf}$  reduces with decreasing mass  $m$ . In conditions where the fire grows and flashes over relatively quickly, the decay rate is approximately linear. The time to reach burnout following flashover can then be estimated by

$$t_{bo} = 2m_o/m_{pfo} \text{ seconds} \quad (8.17)$$

where

$m_o$  = mass remaining at flashover (kg, and  
 $m_{pfo}$  = peak mass loss rate at flashover (kg/s)

Alternatively, or in cases where the fire is ventilation controlled, the decay rate may be determined in accordance with Section 8.6.5.

### 8.6.4.4 Window Breakage

The breakage of glazing in windows is an important consideration because it acts as a barrier before breaking and as a vent after breaking. The time and nature of the breakage is difficult to predict because it depends upon the fire, the material type and the frame which supports the glass. Unless these conditions are known or can be reasonably predicted, the assumption of windows acting as barriers or vents should be determined on the basis of the combination of closed or opened windows that will result in the most severe fire in terms of the acceptance criteria. For Level 3 analysis, the consequences of various combinations form part of the analysis.

## **Chapter 8 - Fire Initiation and Development**

If the temperature differential  $\Delta T_g$  between the glass faces can be reliably predicted, then ordinary float glass windows breaks at  $\Delta T_g \approx 80^\circ \text{C}$  whilst tempered glass breaks at  $\Delta T_g \approx 240^\circ \text{C}$ .

### **8.6.4.5 Other openings**

Other openings may be created or developed during the fire and should be considered, e.g. the opening of relief louvres in a warehouse. Openings developing in barriers are dealt with in Chapter 10. Activation of smoke management equipment can also influence the amount of ventilation to the fire enclosure.

### **8.6.5 Decay phase**

When 80% of the fuel has been consumed the fire shall be assumed to decay at a linear rate given by :

$$Q(t) = (1 - 1.75(t - t_d) / t_b) Q_{\max} \quad (\text{MW}) \quad (8.18)$$

where

$t_d$  is the time of onset of the decay phase

$t_b$  is the duration of fully developed burning

$Q_{\max}$  is the heat release rate during the fully-developed burning phase

### **8.6.6 Interventions**

#### **8.6.6.1 Impact of suppression system**

A constant heat output after suppression action is the conservative approach. If the fire is controlled such that it does not spread further, then the duration for which the heat output remains constant can be estimated as the time required to fully consume the portion of burning fuel at a mass loss rate corresponding to  $Q_{ta}$ .

A less conservative approach is to assume that there is some reduction in heat release rate after suppression activation. There is some theoretical and experimental evidence for this approach. (Refer to Chapter 11).

#### **8.6.6.2 Impact of Brigade Fire Fighting**

There is little available in terms of prediction methods or data to estimate the effects of the fire brigade on the heat release rate of the fire.

For Level 1 and Level 2 analysis, fire fighting activities shall be taken as having no impact on the fire.

For level 3 analysis, each of the three possible impacts of extinguishment, control and no control should be considered and the appropriate probabilities used for each outcome in the analysis (refer to Chapter 13). The probability distribution for fire brigade arrival time is available in Australian Fire Incident Statistics. Statistics on brigade effectiveness (measured in terms of extent of fire spread and fire control time) is also available. The FEDB may be able to provide information on the fire brigade suppression capacity  $Q_{\text{control}}$ .

### 8.6.6.3 Impact of Occupant Fire Suppression

Again, there is little in the way of prediction methods for estimating the time of intervention or effectiveness of occupants in extinguishing a fire.

Some data is provided in Chapter 11 that may assist in estimating occupant performance in the use of portable extinguishers.

### 8.6.7 Flame Height

For some ignition calculations and for operation of flame detectors, a method for estimating flame height is required.

Given the rate of heat release, the height of continuous flaming region, for an unconfined plume, may be determined from the equation below:

$$l_c = 0.08 Q^{2/5} \quad (8.19)$$

where

$l_c$  is the height of continuous flame (in m);  
 $Q$  is the rate of heat release (in kW).

The relationship between the rate of heat release and the height of the intermittent flame may be calculated using the following equation:

$$l_i = 0.20 Q^{2/5} \quad (8.20)$$

where

$l_i$  is the height of intermittent flame (in m);

For radiation calculations, the flame height and fire diameter can be used to determine the flame radiation area. This area can then be assumed to be radiating at a value of 150-200 kW/m<sup>2</sup> for design purposes.

### References

Babrauskas V., "Will the Second Item Ignite", Report NBSIR 81 - 2271, National Bureau OF Standards, Gaithesburg, MD, 1981

Tewarson A., "Generation of Heat and Chemical Compounds in Fires", SFPE Fire Protection Handbook, Second Ed., Section3 / Chapter 4, pp 3 - 53,1988.

Drysdale D., "An Introduction to Fire Dynamics", Chichester, John Wiley and Sons, 1985.

Babrauskas V. "Burning Rates", SFPE Fire Protection Handbook", Second Ed., Section3 / Chapter 1, pp 3 - 1, 1988

Thomas P. H., "Testing Products and Materials for Their Contribution to Flashover In Rooms", Fire and Materials, Vol. 5, pp 103 -111, 1981

## Chapter 9 - Smoke Development and Management

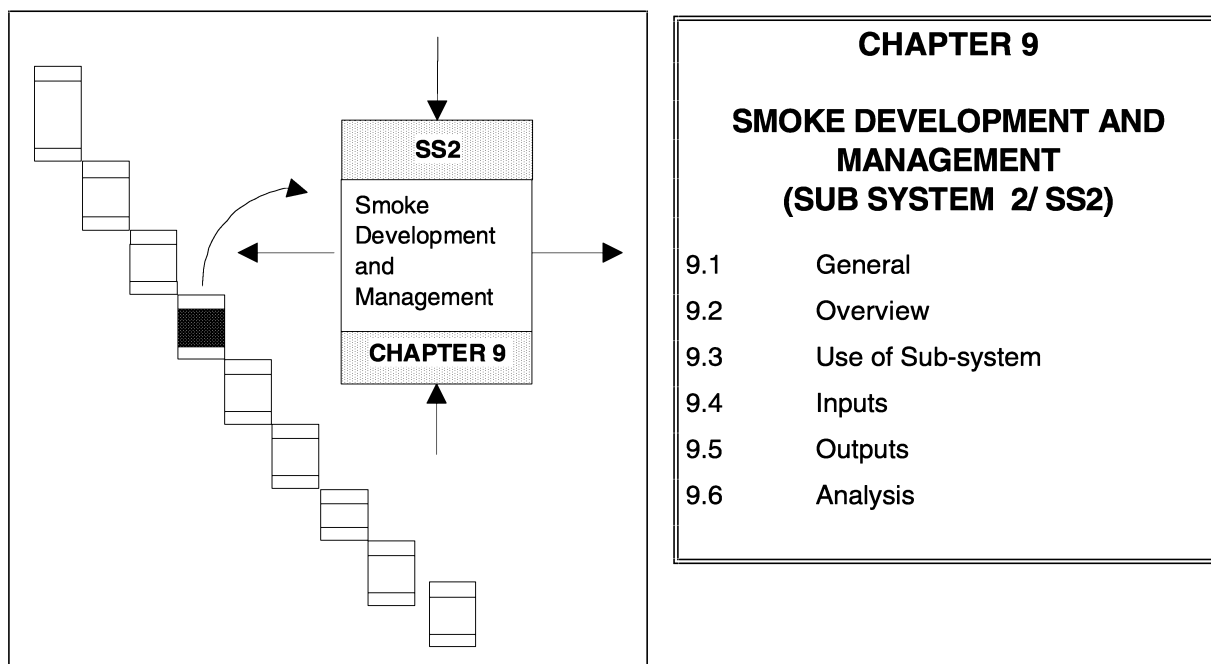

### 9.1 General

The smoke development and management sub-system provides the basis for calculation of the following:

- (i) the development of smoke and toxic gases within the fire enclosure origin.
- (ii) the spread of smoke to enclosures beyond the fire enclosure.
- (iii) the characteristics of the smoke, particularly those parameters that constitute untenable conditions.

This sub-system also examines performance of smoke management systems that may limit the development of smoke or prevent its spread to areas where occupants or valuable property are exposed.

In AS 2484.1 (1990), smoke is defined as " a visible suspension in air of solid or liquid particles or gases resulting from combustion or pyrolysis". This does not include entrained air that adds to the volume of smoke as it moves. In order to avoid having to write 'smoke and toxic gases' and to qualify statements continually about whether entrained air is included or not, these Guidelines will use the following definition:

"Smoke is defined as the mixture of products of combustion with air". By this definition, visible and invisible products, toxic and non-toxic products, convective heat and entrained air are included.

This sub-system takes characteristic fire profile and species/smoke yields from SS1 to develop time to untenable conditions.

### 9.2 Overview

#### 9.2.1 General

The procedures described in this chapter provide the means of establishing the rate of development of smoke, its spread within the fire enclosure and beyond, and the properties of the smoke at locations of interest.

## **Chapter 9 - Smoke Development and Management**

These procedures enable the establishment of the time and probability of reaching untenable conditions and a means to estimate the response of smoke detectors.

The chapter also covers the means by which smoke management systems can be provided in buildings to limit or prevent the spread of smoke within the fire enclosure or into other building enclosures.

The characteristics of smoke that are of principal interest for engineering calculations are:-

- (i) the temperature of the smoke
- (ii) the depth of the hot smoke layer
- (iii) the optical density of the smoke
- (iv) the concentration of toxic gases, particularly CO.

These parameters (i) to (iv) provide the basis for identification of untenable conditions ie. conditions that are life threatening to occupants.

Other characteristics of smoke may be important for some design situations in relation to property damage, particularly sensitive equipment such as computers and electronic control equipment. Critical parameters may include temperature, particulate concentration or corrosive gas concentration, particularly combustion gases such as HCl.

### **9.2.2 Factors Affecting Smoke Development**

The factors which affect the rate and quality of smoke production include:-

- smoke potential
- toxic gas/soot yield
- rate of burning (heat release rate)
- ventilation conditions

This shows that the rate of smoke production is related not only to the mass of smoke (or yield fractions) produced per unit mass of material burnt but is related strongly to the rate of fire growth. For example, a plastic material may have a smoke yield similar to that of a cellulosic material, but burn far more quickly and hence have a much greater rate of smoke production than the cellulosic material.

### **9.2.3 Smoke Movement in the Enclosure of Fire Origin**

For fires of any significant energy, it is usual for the smoke to rise due to its own buoyancy. As the smoke rises, cool air is entrained and the temperature, particulate concentration and toxic gas concentrations are reduced.

However, the volume of smoke is increased, although visibility per unit volume of smoke increases.

During this vertical rise under buoyancy, the mass flow of air entrained usually greatly exceeds the mass flow of burned fuel and the latter term is therefore usually ignored.

When a smoke plume from a fire reaches an enclosure ceiling, it turns and spreads horizontally forming a ceiling jet and then a hot layer beneath the ceiling. In this slower horizontal flow, less air is entrained.

Given that smoke is mostly gaseous, the movement of smoke is generally governed by the laws of fluid dynamics and the gas laws.

## **Chapter 9 - Smoke Development and Management**

The force that creates the movement are thermal (buoyancy) and pressure (fire induced and external). The physics and chemistry of development of smoke, plume entrainment, and movement are generally built into compartment fire models that are often used for engineering calculations.

### **9.2.4 Smoke Spread Beyond the Enclosure of Fire Origin**

Smoke movement out of an enclosure can only occur via the presence of openings, either large ones such as doors and windows or through small distributed leakage paths. As soon as smoke leaves the enclosure of fire origin, it begins to be cooled by the entrainment of air and by the loss of heat to the surroundings.

Where the smoke leaves the fire enclosure via small openings, the entrainment and surroundings cool the smoke more quickly. Smoke flow through large openings cools slower by entrainment because of its larger mass.

Once the smoke is sufficiently cooled (ie. buoyancy forces are low), the movement of smoke is then influenced by other forces which may be present such as:

- Stack effect
- Wind effect
- Mechanical air handling systems

Detailed mechanisms for spread of smoke are provided in the SFPE Handbook of Fire Protection Engineering (SFPE : 1995) and Klote & Milke (1992). There are mathematical relationships and models developed to predict spread of smoke in buildings.

### **9.2.5 Smoke Management**

Methods for management of smoke fall into 5 general categories:

- smoke exhaust
- smoke dilution
- smoke containment
- pressurisation
- opposing airflow

All forms of smoke management are designed to either:

- (i) keep smoke away from occupants or equipment, particularly in the enclosure of fire origin, or
- (ii) prevent spread of smoke to adjoining enclosures

Smoke exhaust and dilution methods are aimed at achieving a separation between an upper layer of smoke and a lower layer of relatively clean air in which occupants or equipment may be located. These systems rely on exhausting smoke from the hot layer and replacing it with fresh air at lower level.

On the other hand, containment can be provided by physical barriers, such as doors, to prevent smoke flow through openings. This may be supplemented by air pressurisation where remaining openings are small eg. around closed doors into stairwell, or by higher velocity flows for larger spaces that are not closed off.

## Chapter 9 - Smoke Development and Management

### 9.2.6 Smoke Characteristics

Given that we can predict the rate of smoke development and its spread, we need to be able to calculate the characteristics of the smoke at any location to see if untenable conditions or some other performance characteristic (eg. particulate concentrations that could affect computers) have been reached or exceeded. The level of smoke, often expressed in optical density terms, can be used to estimate the time for operation of smoke detectors. The temperature of smoke can also be used to estimate the time of operation of heat detectors and sprinklers, although another technique is provided for this in SS3.

Conditions for untenability need to be set during the FEDB process. (Chapter 4) In practice, this usually means only temperature and depth of the hot layer (really height of the bottom of the hot layer above the floor) need to be calculated for most engineering purposes. The optical density may be useful for smoke detector operation, but toxic gas calculations are usually not required for the majority of designs, except where unusually toxic combustion products are expected or in other specially hazardous situations.

The SFPE Handbook provides more detail on the effects of smoke and toxic gases.

### 9.2.7 Measurement of Smoke

The amount of smoke is measured by its mass (kg) or its volume (m<sup>3</sup>) and its rate in (kg/s) or volume flow rate V (m<sup>3</sup>/s).

The degree of 'smokiness' of a unit volume of smoke is often expressed in particulate concentration terms (ie density - kg/m<sup>3</sup>) or by its optical density (ie effect on a light source or visibility).

There is a great deal of confusion between optical density terms and units and therefore it is important that they are defined for the purposes of these Guidelines.

Optical density (D) of smoke is defined by the attenuation of a light beam according to the equation.

$$D = -\log_{10}(I/I_0) \quad (\text{no units}) \quad (9.1)$$

where  $I$  = intensity of light with smoke  
 $I_0$  = intensity of light with no smoke

$$\text{The ratio } I/I_0 = \exp(-kCL) \quad (9.2)$$

where  $k$  = absorption coefficient of smoke  
 $C$  = mass concentration of smoke  
 $L$  = path length of the optical beam.

Often, optical density is expressed as optical density per unit length ( $D_L$ )

$$D_L = -1/L \log_{10}(I/I_0) \quad (9.3)$$

where  $D_L$  has units of m<sup>-1</sup>

Another popular expression is optical density per unit length (OD) expressed in units of db/m that can be related to visibility (Drysdale:1985).

$$OD = -10/L \log_{10}(I/I_0) \quad (9.4)$$

where OD has units of db/m (obscura).

## **Chapter 9 - Smoke Development and Management**

Drysdale (1985) shows that optical density (dB/m) can be related to visibility (m) with an optical density of 1 dB/m being equivalent to a visibility of about 10 m.

Finally, smoke may be defined in terms of its percentage obscuration (OB) of smoke, simply by the expression.

$$OB = 100 / L (I_o - I) / I_o \quad (9.5)$$

where OB has units of %/m

It is important that all these terms are well understood as the various zone models, smoke detection prediction methods, and smoke production equations use some or all of these expressions for the degree of 'smokiness'.

### **9.2.8 Interactions**

#### **9.2.8.1 Effect of Air Handling Systems**

The influence of an air handling system on the movement and spread of smoke depends on:

- (i) its normal operational mode, and
- (ii) its fire mode operation

It is important that these influences are understood when choosing compartment fire models and undertaking calculations. For example, in high airflow computer rooms, the 2 zone assumption may not hold unless air is injected at the bottom and extracted from the top of the enclosure.

Similarly, if the air handling is shut down or goes into some exhaust or zone pressurisation mode, this will have a substantial effect on movement of smoke.

Particular attention needs to be paid to the disturbance of the hot layer caused by air flows induced by the air-handling system. Supply air-registers located within the hot layer will increase the volume of the hot layer, decrease its temperature and if the hot layer is not sufficiently buoyant, will mix the layer into the cold layer below.

High velocity air flows such as might occur from a door jet also have been shown to disturb the hot-layer. The degree for which this happens is dependant upon the buoyancy of the layer and the velocity of the flowing air. It must be remembered that all flowing air streams will entrain air (or smoke) into them (drop of pressure with velocity). Thus all substantial air-flow beneath the hot layer is likely to draw smoke down to low levels which could effect visibility. CFD programs are capable of predicting this phenomena.

#### **9.2.8.2 Effect of Sprinklers**

The operation of sprinklers during the fire has the tendency to drag the upper smoky layer downward, thereby reducing visibility in the lower layer. This is usually a localised phenomenon and not a serious problem if adequate venting of the smoke has been provided.

In any case, the effect of the sprinklers in reducing the production of smoke by suppressing the fire (and hence reducing the production of heat as well) is usually far more beneficial than the undesirable localised effect of mixing the upper smoky layer with the lower layer.



## **Chapter 9 - Smoke Development and Management**

From a design viewpoint, the operation of sprinklers is usually used to set the limit on the fire size, and hence the smoke production rate, for smoke control design.

Another interaction to be noted is that of smoke ventilation systems possibly affecting sprinkler operation. This potentially occurs in large buildings, such as factories and warehouses, where natural or mechanical smoke extraction systems are thought by some to affect the performance of sprinkler systems, particularly of the ESFR and large drop type.

### **9.2.8.3 Environmental Effects**

Both the stack effect and external wind pressure conditions can have a significant effect on smoke movement within a building and need to be carefully considered by designers.

Flow of smoke beneath the ceiling or roof results in a cooling of the smoke due to both radiative and convective heat losses. The cooling can result in a loss of buoyancy whereby the “not so hot” layer will mix with the cooler layer or descend to low levels. This is particularly evident near inlets or in regions where there is a significant flow beneath the hot layer.

## **9.3 Use of Sub-system**

### **9.3.1 General**

The flow chart presented in figure 9.1 outlines the main stages of modeling of the movement of smoke and toxic gases within and beyond the enclosure of fire origin. In using the flowchart it is assumed that the location and the rate of growth of the fire has been established.

### **9.3.2 Locations of interest**

During the FEDB the locations of interest in terms of the potential impact of smoke spread should have been established. These locations may include:

- the positions where the occupants may be at risk;
- the positions of smoke and heat detectors likely to be first activated;
- the positions of fire detectors linked to active systems, such as self-closing fire doors, shutters, extinguishing systems, smoke curtains etc. .

The locations of interest may change over time as the fire develops and spreads. Where several locations of interest are considered, separate sets of calculations may be necessary.

## **9.4 Inputs**

### **9.4.1 Geometry of enclosure**

The following parameters are relevant:

- Floor area
- Ceiling height

## Chapter 9 - Smoke Development and Management

- Slope of ceiling
- Width of openings
- Height of openings
- Size of window opening
- Height of openings from floor level
- Size of vent on roof

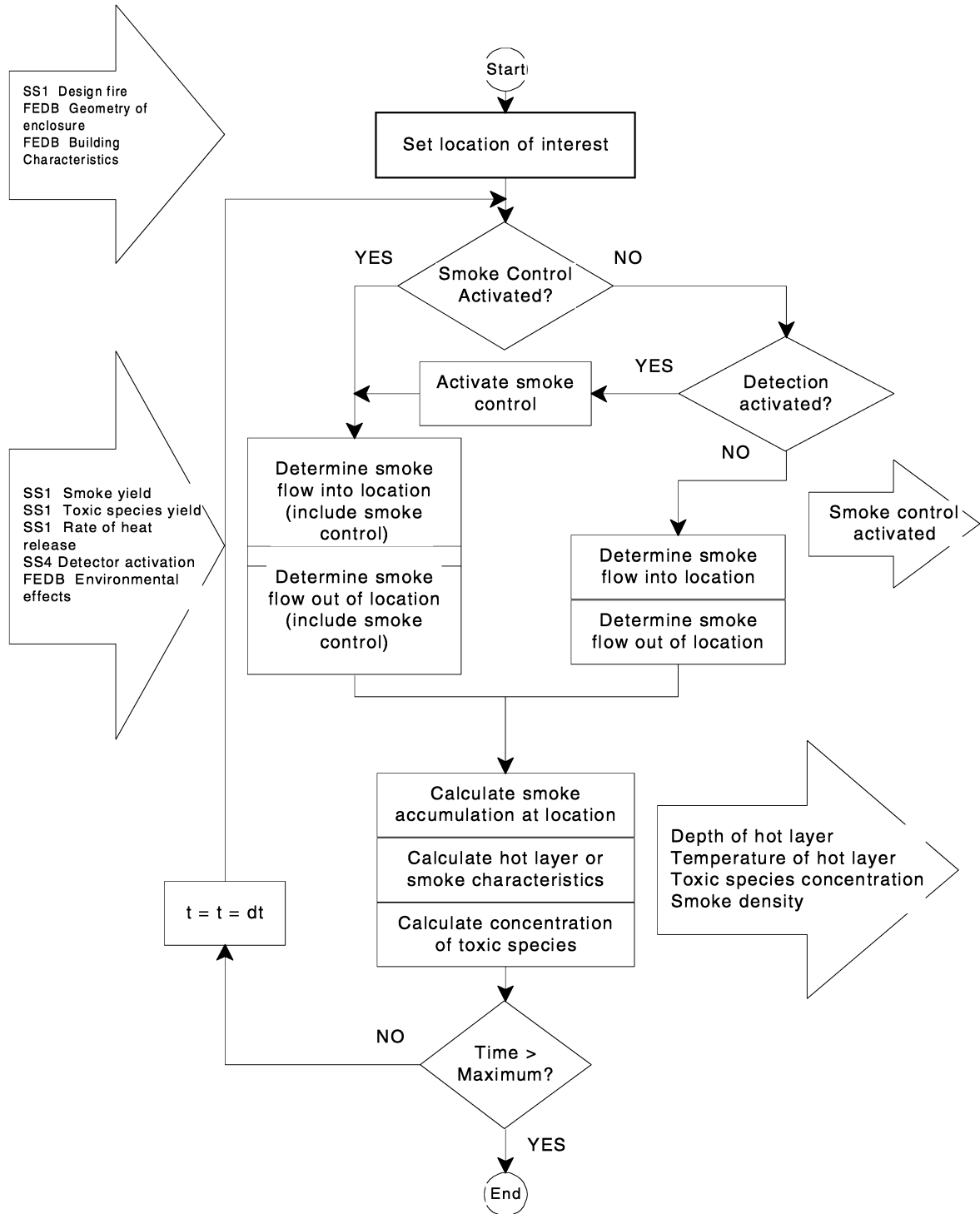

**Figure 9. 1 Flow chart for smoke spread**

## **Chapter 9 - Smoke Development and Management**

### **9.4.2 Building characteristics**

The following parameters are relevant:

- Thermal properties of internal linings
- Flow rate of exhaust fan
- Flow rate of make-up air
- Delay in activation of fans from detection time
- Delay in changing configuration of flow-control devices such as doors, dampers
- Locations on inlet and exhaust vents
- Dimensions of natural vents
- Position and size of natural openings

### **9.4.3 Rate of heat release profile**

Rate of heat release versus time is obtained from SS1.

### **9.4.4 Toxic species yield**

The yield of toxic species, particularly carbon monoxide CO, is obtained from SS1.

### **9.4.5 Smoke yield**

The yield of smoke from the fire is obtained from SS1.

### **9.4.6 Time of detector activation**

When activation of a detection system is used to initiate smoke management systems, the time of activation is derived from SS4.

### **9.4.7 Environmental effects**

The FEDB should establish whether environmental effects are likely to be significant and data may be required regarding:

- the velocities and prevailing direction of wind where this may cause adverse pressures at vent and inlet locations;
- the temperature of internal air beneath the roof, where this may cause stratification;
- internal air movements caused by the HVAC systems which might for example affect the ability of smoke to reach detectors.
- Internal air movements likely to impact on hot-layer stability and smoke flow

## **9.5 Outputs**

### **9.5.1 Smoke temperature**

This may be used to establish the time of heat detector activation in SS4 (Chapter 11) or to establish whether temperature conditions are tenable for occupants or firefighters (SS6 - Chapter 13).

## **Chapter 9 - Smoke Development and Management**

### **9.5.2 Smoke optical density**

This may be used in sub-system 4 (Chapter 11) to establish the time of smoke detector activation or the time at which visibility falls to an unacceptable level.

### **9.5.3 Toxic species concentration**

The toxic species or carbon monoxide profile may be used to establish when the concentration of toxic combustion products reaches an unacceptable level (required for Chapter 6 evaluation).

### **9.5.4 Depth of hot layer**

Depth of the hot layer may be used to establish whether the occupants are likely to be subjected to the conditions prevailing within the hot layer (required for Chapter 6 evaluation).

## **9.6 Analysis**

### **9.6.1 General**

The prediction of the output parameters for this sub-system is generally by the use of an appropriate smoke transport or fire modelling methods.

The design methods predict the transport of the smoke from the fire to the location of interest. In this transport process, air is entrained into the smoke resulting in :

- increase in volume;
- decrease in temperature;
- dilution of smoke concentration; and
- dilution of toxic species

The following output parameters for smoke at the location of interest are determined from consideration of the smoke and species yield and the degree of dilution:

- smoke density
- toxicity
- temperature

Sub-system 1 provides the yields for these parameters per unit mass of material burned. Another important output parameter in many design situations is the depth of the hot smoke layer.

Calculation of the smoke transport and the resultant dilution can be undertaken by the following means :-

- hand calculations
- zone models
- field models (CFD)

Field models are most suitable when considering complex geometries or flow throughout the building. One limitation in this context is due to the large computational mesh that is required to represent a complex geometry.

## Chapter 9 - Smoke Development and Management

### 9.6.2 Smoke Production in Enclosure of Fire Origin

#### 9.6.2.1 General

The mass, volume, temperature, toxic species and height of the smoke layer can be calculated and analysed in three ways:

- equations (hand calculations)
- zone models
- field models

It is crucial that if computer based models are used that the assumptions and limitations inherent in these models are well understood by the user.

#### 9.6.2.1 Basic equations

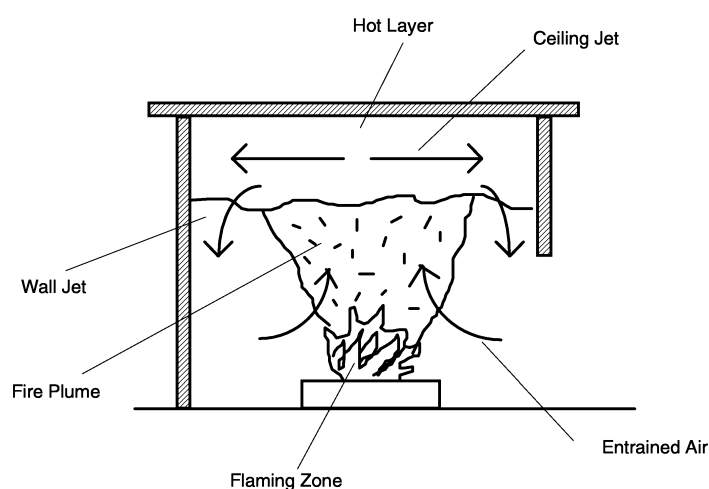

**Figure 9.2 Fire and Smoke Development**

In simple terms (as shown in Figure 9.2), the analysis of fire and smoke development can be divided into an analysis of

- the flame zone
- the fire plume
- the ceiling jet
- the hot upper layer

Text books such as the SFPE Handbook (1995), Klote and Milke (1992) and Drysdale (1985) provide a wide range of equations to describe the temperature, mass flow rate, CO concentration etc. at different heights within the enclosure of fire origin. Some of these basic equations has been provided in any easy computer calculation format in packages such as FireCalc (1993), FPETOOL (1990) and ASKFRS (1988).

Fire engineers, therefore, do not always need to resort to complex fire models but may estimate the development of critical fire parameters of interest using these relatively simple equations. Like all design methods and models, users must be aware of the fundamental assumptions, range of applications, and any limitations of the equations.

Key equations to be used in analysis of smoke development and spread include those for:

- smoke production rate

## Chapter 9 - Smoke Development and Management

- plume temperature
- hot layer temperature
- maximum height

For smoke production, the simplified axisymmetric equation of Thomas (1991) or the axisymmetric plume equation of NFPA 92B may be used if the fire is away from walls and air entrainment into the plume can occur from all sides.

Where air entrainment is restricted, other equations have been developed for mass flow into plumes for

- plumes flowing from under a balcony
- plumes flowing through doors and windows

Designers need to use the appropriate equations where walls, balconies, windows etc. interfere with air entrainment.

Using these and/or other equations, it is possible to hand calculate parameters such as height of the hot smoke layer, layer temperature, CO concentration and smoke volume that a designer needs to:

- estimate time to untenable conditions
- design effective smoke management systems

### 9.6.2.2 Zone Models

Zone models generally can be used to compute a range of parameters varying with time in the enclosure of fire origin. In multi-room zone models, such as CFAST, these parameters can also be computed in other adjacent, connected enclosures together with flows between enclosures to predict smoke spread.

Zone models divide enclosures into two or more simple zones, usually:

- Hot upper gas layer
- cool lower gas layer
- fire plume

This is illustrated in Figure 9.3

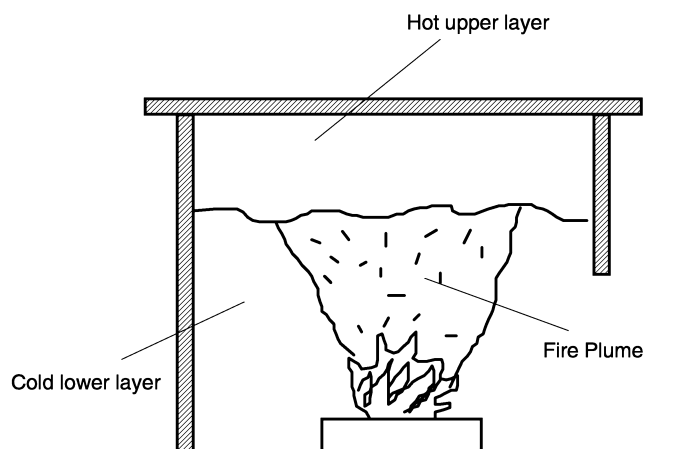

**Figure 9.3 Typical enclosure zones**

## **Chapter 9 - Smoke Development and Management**

The zone models generally assume that parameters such as temperature, toxic gas concentration, etc. are uniform throughout each zone with only the parameters of the hot layer being of interest for fire engineering calculations. Zone models will in many cases provide sufficient accuracy for engineering design purposes. However this basic assumption of zone models may break down and limit the use of such models in some situations. Some examples of situations where zone models may not be appropriate or may need to be used very conservatively are:

- low buoyancy fire conditions
- buildings with long corridors
- enclosures with forced ventilation
- large enclosed spaces such as warehouses and atria
- complex building geometries

The fundamental limitation of zone models arise from inability of the simple zone approximation to properly represent the physical phenomena. This is most often manifested when the stability or the existence of a distinct hot layer is lost.

The hot layer may be destroyed by mixing with the bottom ambient layer and this can be caused by any of the following :-

- Excessive inward velocity of door jets
- Excessive inlet air at ceiling or high levels above the smoke layer interface
- Cooling of the hot layer (particularly in large spaces)
- Drag induced by sprinkler system water spray

The zone-modelling approach relies on the development of a stable hot layer. Caution must therefore be exercised in applying zone models in situations where the above causes for hot-layer disturbance are likely. The stability of the layer is related to its buoyancy and hence hotter layers are more stable and the zone models are better able to properly represent the situation.

Disturbance of the hot layer by the action of high velocity water droplets depends on the buoyancy of the hot layer as well as the relative horizontal surface areas involved. This area is still in need of further research but it is important to consider possible loss of the hot layer due to sprinkler action.

For the purpose of these Guidelines, zone models should at least predict the following parameters in the enclosure of fire origin:

- hot layer height
- temperature of the hot layer
- optical density of smoke in hot layer

For some analyses, it may be required that such zone models also predict:

- concentration of toxic gas species in the hot layer
- opening flows, particularly extraction rates of smoke by natural or mechanical systems

It should be noted by designers that those values of parameters calculated will be average values for the hot layer.

There are many zone models available incorporating a range of different plume equations and other physics. It is not intended to repeat any or all of these equations in the Guidelines. They can be found in a wide range of text books such as the SFPE

## **Chapter 9 - Smoke Development and Management**

Handbook, Fire engineers, however, need to be aware of the following criteria when choosing and using one or more zone models for a particular design situation:

- basic fire physics/plume equation
- enclosure length/width/height aspect ratio limitations
- limitations on enclosure height and flow area/volume
- limitation on fire size (heat release rate)
- effects of building air handling systems
- whether the axisymmetric plume assumption holds or not
- are zone model input data conservative?
- verification against experimental/real fire data
- numerical accuracy of results
- uncertainty of results

More details on assessment and verification of fire models, including zone models are given in Appendix 9A.

Comments on these and other relevant aspects of usage/assumptions/limitations should be included in the final design report (see Section 4).

### **9.6.2.3 Field Models**

Rather than giving average values for major fire zones, field models divide the enclosure into a series of cells and solve the conservation and flow equations in each cell. Fire safety parameters of temperature, velocity, smoke concentration etc. are then predicted at a range of locations. The process of calculation is often referred to as computational fluid dynamics (CFD) modelling.

As a result, field models have the potential to solve many fire safety problems in large, complex spaces or enclosures with special air handling systems if the models have been properly validated for these situations. However, many field models are still in a development phase and verification is limited. Special care must be exercised by designers using CFD/field models.

Field models must predict the critical SS2 output parameters needed for design purposes.

Field models used for the prediction of untenable conditions must have at least the following features:

- capability of considering a fire developing with time (non-steady state)
- sufficient spatial resolution in particular around the fire plume, to properly resolve entrainment
- convergence when infinitesimal time intervals changes within acceptable limits



## **Chapter 9 - Smoke Development and Management**

- stability within time intervals sufficient for practical needs.

More details on the fundamental equations, use, limitations and other aspects of field models is presented in Appendix 9B.

### **9.6.3 Smoke Spread to Other Enclosures**

#### **9.6.3.1 General**

The prediction of quantity and quality of smoke that may spread to enclosures beyond the enclosure of fire origin can be undertaken by:

- equations (hand calculations)
- zone models
- field models

Simple hand calculations may be possible for smoke flow from the compartment of origin. Zone models may be used where the two-layer approximation is still valid. This generally restricts their applicability to compartments not remote from the compartment of fire origin.

Network or flow models (ASCOS) are appropriate where consideration is for smoke far removed from the source. These models consider typically forces due to buoyancy (including stack effect within building) and those generated by the air-handling system.

Field models are most suitable when considering complex geometries or flow throughout the building. Their limitation in this context is only due to the large computational mesh that is required to represent a complex geometry.

Such methods must allow the fire safety engineer to estimate the time to establishment of untenable conditions or other property criteria in all building enclosures of interest.

#### **9.6.3.2 Equations**

The basic equations are provided for the major mechanisms of smoke spread as follows:

##### **Movement Through An Opening**

Smoke movement through an opening is governed mainly by the pressure difference which exists across the opening. This is shown schematically in Figure 9.4.

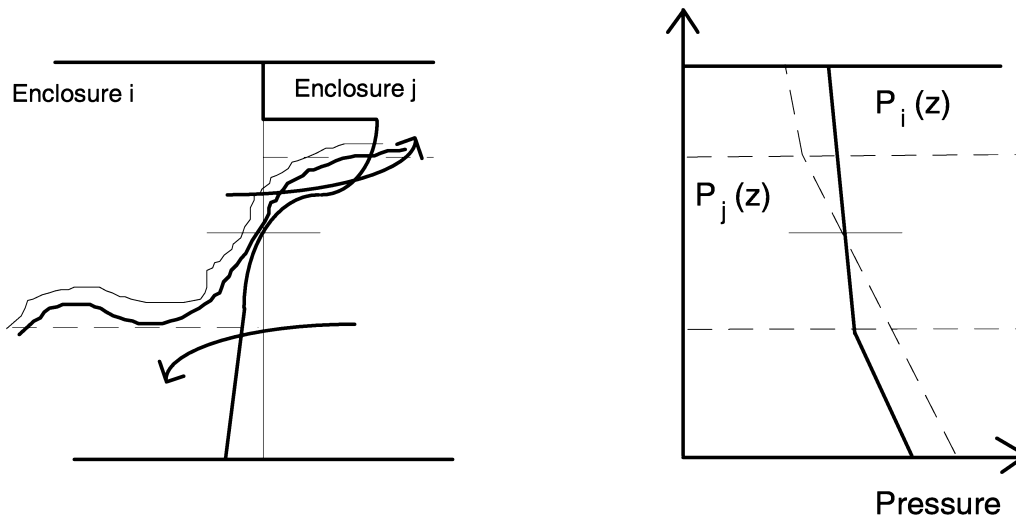

**Figure 9.4 Typical Flow Schematic Across an Opening**

The mass flow rate through the opening ( $\dot{m}_o$ ) is given by

$$\dot{m}_o = wC(2\rho)^{1/2} \int_{z_1}^{z_2} (P_i - P_j) dz \quad (9.6)$$

where

- $w$  = opening width (m)
- $C$  = opening (orifice) coefficient (no units)
- $\rho$  = density of air (smoke) at the source of the flow ( $\text{kg/m}^3$ )
- $P_i$  = pressure in enclosure i (Pa)
- $P_j$  = pressure in enclosure j (Pa)
- $z$  = height (m)

Doors, when opened, form the main channels for smoke movement because of their relatively large sizes. Unless excessive, the undercut or the gap between the door and its frame is not usually significant in contributing to smoke spread when the doors are closed.

Construction openings in barriers, which are created to allow the penetration of ducts, can become migratory paths for smoke if they are not properly sealed. Openings can be large, particularly in concealed areas, and, because they usually penetrate throughout the building, can permit the rapid spread of smoke.

### Vertical Movement of Smoke

The vertical movement of air within buildings is normally through vertical spaces such as elevator shafts, stairwells and service ducts. In tall buildings, temperature differences between inside and outside the building will give rise to buoyancy-induced pressure differences known as stack effect.

Equations that can be used to calculate the stack effect are given in references such as Klote and Milke (1992).

## **Chapter 9 - Smoke Development and Management**

### **9.6.3.3 Zone Models**

Multi-room zone models are available to predict the flow of smoke between enclosures and calculate the height of the smoke layer, smoke temperature and concentration, etc. in the enclosures connected to the enclosure of fire origin.

The same criteria applicable to selection, use, and limitations on one enclosure zone models apply equally to multi-room zone models. Designers need to evaluate carefully the vent flows between enclosures to ensure they are reasonable and realistic.

### **9.6.3.4 Field Models**

Field models may also be used to evaluate smoke spread and smoke layer development in enclosures beyond the enclosure of fire origin. Again ideally field models are suited to large buildings and those with complex airflows and geometries. However the same concerns about validation and limitations of field models applies.

## **9.6.4 Smoke Management Techniques**

### **9.6.4.1 General**

The calculation of the effects of smoke management techniques can be divided into two categories.

- (i) prevention of smoke threat in the enclosure of fire origin
- (ii) prevention of smoke spread to adjoining enclosures

For all smoke management techniques, designers should evaluate each the following:

- (a) time of activation
- (b) time of failure
- (c) probability/reliability of activation and effectiveness
- (d) performance capacity (eg. extraction rate or pressure difference required)

The principles inherent in calculation of smoke management techniques that should be demonstrated in the design and project report include the following:

- determine maximum fire size (may be limited by sprinkler operation)
- calculate the smoke production rate for this maximum fire size
- calculate the smoke extraction rate, pressure required or other parameter that will be required to prevent untenable conditions or fire spread
- size the fans/ducts, vents etc. and activation/control systems required to achieve the performance objective

### **9.6.4.2 Enclosure of Fire Origin**

The threat of smoke to occupants and/or equipment and contents may be avoided by smoke management techniques that include:

- (i) natural accumulation

## **Chapter 9 - Smoke Development and Management**

- (ii) natural ventilation
- (iii) mechanical extraction

Calculations should be undertaken to demonstrate that untenable or other acceptance criteria are not exceeded in all enclosures of interest.

For techniques (ii) and (iii), models exist to estimate extraction rates, size of vents or fans, etc. Most importantly, consideration of required inlet air quantities is a necessary part of the design process. Such models include Hotlayer, Roofvent, Yardstick and others that should be only used if appropriate and within the model assumptions and limitations.

Design codes such as AS 1668 should also be consulted. However, designers should be aware that compliance with AS 1668 in small enclosures may not guarantee tenability in the enclosure of fire origin as required by the BCA.

### **9.6.4.3 Containment - Prevention of Fire Spread**

Containment of smoke may be achieved by physical barriers such as floors, walls and doors. However, leakage through barrier penetrations may be contained through pressurisation for situations such as:

- between floors (zone pressurisation)
- between open floors and stairways (stair pressurisation)

Again, design standards such as AS 1668 and NFPA92B may be used together with, if necessary, complementary hand calculations or computer models to ensure a pressure design objective is met. Given a typical buoyancy pressure of 18 Pa is appropriate for a three metre ceiling, a design figure of 20 Pa positive pressure to prevent smoke leakage is often used. If ceilings are higher, then buoyancy pressures may be greater, and higher pressures may be required to prevent spread of smoke. Care must be taken to ensure higher pressures do not lead to excessive pressures on doors that may inhibit occupant escape.

### **9.6.4.4 Time to Activation**

Smoke management equipment generally requires automatic activation, although manual operation is often also provided for fire brigade action.

Activation signals are often provided automatically by smoke detectors or automatic sprinklers. The time of activation is therefore provided by SS4. A time delay between detector operation and fan/damper/vent activation may be significant and should be calculated.

The approach of AS 1668 is to provide smoke management activation by smoke detectors limited to locations adjacent to or within airconditioning return air/supply air ducts. This may also lead to a significant delay in effective smoke management operation. If a sprinkler system or full building smoke detection system is provided, an alarm signal from these systems could be utilised or may be required to provide earlier activation of smoke management to ensure that life safety or other performance criteria are met.

### **9.6.4.5 Time to Failure**

Designers should consider the factors that could contribute to failure of smoke management techniques. These include:

## **Chapter 9 - Smoke Development and Management**

### (i) Smoke extraction

If the fire reaches flashover, the volume of smoke produced would be so great that no practical smoke extract fans could handle

### (ii) Zone pressurisation

The maintenance of a pressure difference between the fire enclosure and the other enclosures depends much on the integrity of the barriers including doors, windows and services penetrations. Failure of these barriers during the fire would cause the failure of the zone pressurisation system.

### (iii) Stair pressurisation

A design of air pressurisation system to AS1668.1 assumes the main discharge door and the door to the fire-affected floor to be fully open only (if the building is provided with a purging smoke control system), plus the door to the floor immediately above the fire floor. During evacuation, more doors to the stairway may be open depending on the emergency procedure, and the pressure in the stairway could be lost to the additional openings. Also it is not certain if the stair pressurisation system is still effective when the fire reaches flashover.

#### **9.6.4.6 Probability of Successful Operation**

Techniques for smoke management exemplify the principle that the greater the complexity the lesser the reliability.

Work by England (1995) and Klote and Milke (1992) show that the probability of success of smoke management designs for multi-storey buildings may be less than 50%. The following table from Klote and Milke provides one basis for estimation of the probability of success of the mechanical side of smoke management systems. However, it should be noted that choice of components and operation and maintenance considerations will affect the probability of success.

**Table 9.1 Reliability and Mean Life of Smoke Control Systems (Klote and Milke)**

System	No. of HVAC System Fans	No. of Other Components	Reliability of New System Before Commissioning	Mean Life of Commissioned System (months)
1	3	0	0.97	116
2	0	3	0.83	46
3	3	9	0.56	14
4	5	18	0.31	8
5	5	54	0.03	3

## **Chapter 9 - Smoke Development and Management**

### **References**

"SFPE Fire Protection Handbook", Society Fire Protection Engineers, Second Edition., 1995

Klote and Milke, "Design of Smoke Management Systems", ASHRAE, 1992

Drysdale D., "An Introduction to Fire Dynamics", Chichester, John Wiley and Sons, 1985.

"FIRECALC, Computer Software for the Fire Engineering Professional", CSIRO, 1993

Nelson H., "FPETOOL : Fire Protection Engineering Tools for Hazard Estimation", NISTIR 4380, National Institute Of Standards And Technology, Gaithesburg, MD, 1990

Chitty R and Cox G, "ASKFRS : An Interactive Computer Program for Conducting Fire Engineering Estimations", BRE, 1988

Thomas P. H., "Testing Products and Materials for Their Contribution to Flashover in Rooms", Fire and Materials, Vol. 5, pp 103 -111, 1981

England P., "Fault Tree Analysis of a Smoke Management System", EQB5070/2, Victoria University of Technology, 23 August 1993



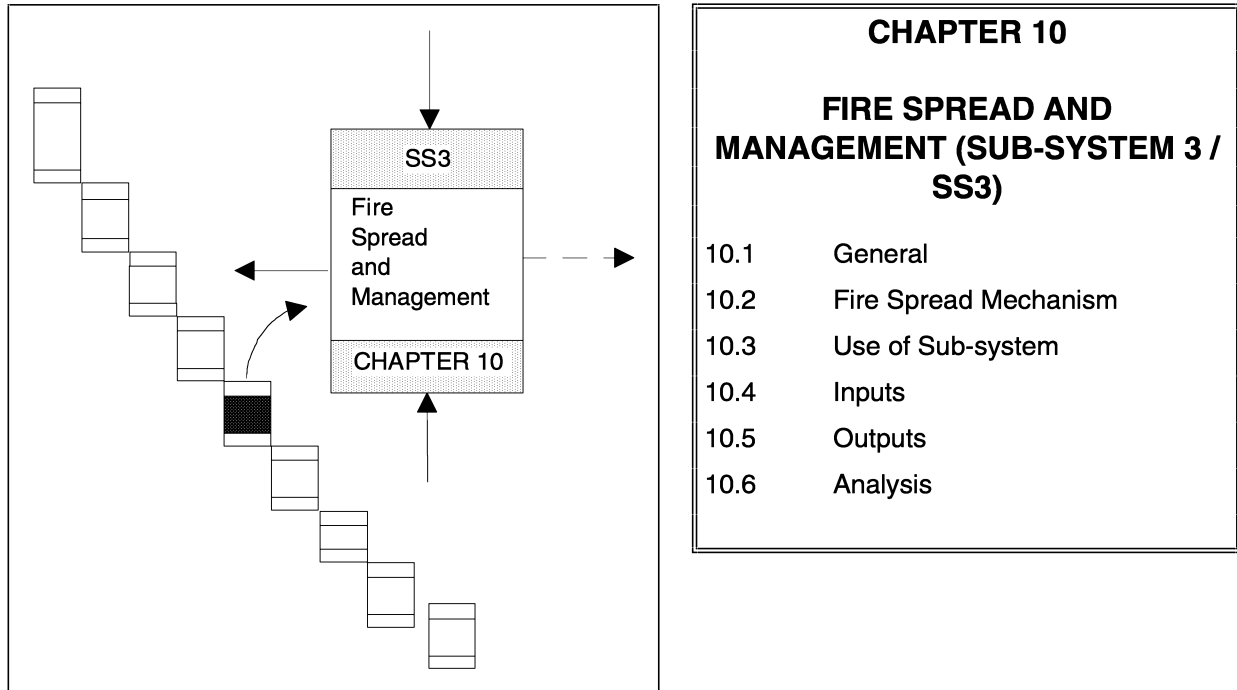

## 10. FIRE SPREAD AND MANAGEMENT (SUB-SYSTEM 3 / SS3)

### 10.1 Scope

The fire spread and management sub-system provides guidance for establishing and managing the circumstances in which a fire developing within an enclosure can spread to areas beyond the fire enclosure. For the purpose of this sub-system, spread beyond the fire enclosure is deemed to have occurred when any material outside the fire enclosure ignites and initiates another fire. Hence flames projecting from openings do not constitute spread unless it ignites another material outside the enclosure. In this chapter, consideration is given for fire spreading to an adjacent enclosure, to areas in a higher level and to another building.

Guidance on predicting the likelihood of fire spreading beyond the fire enclosure is primarily based upon the severity of the fire developing in the fire enclosure. Procedures are described in this chapter to provide the means of predicting the fire severity on the basis of the characteristic fire profile defined in Chapter 8. Procedures which are not based on a fire profile, particularly those which have been specifically developed to assess the performance of structural elements in fire, are also described.

General guidance on managing fire spread is given in Section 5.5. This chapter includes specific guidance on means of reducing the likelihood of fire spreading beyond the fire enclosure. In particular, the procedures described here focus on the ability of components to withstand the effects of fire, such that the likelihood of fire spread is reduced.

### 10.2 Fire Spread Mechanisms

#### 10.2.1 General

This section outlines the circumstances in which a fire developing within an enclosure can spread beyond the enclosure. In particular, the means and routes by which a fire may spread, as well as the factors which may influence the likelihood of spread, are discussed.



### **10.2.2 Means of fire spread**

Fire spread beyond the fire enclosure occurs when one or more objects outside its enclosure boundaries ignite and burn. For objects outside the fire enclosure, the mode of ignition may be either piloted or non-piloted. Piloted ignition occurs through direct flame impingement due to burning of the hot gases outside the opening or by flying brands from the fire enclosure. Fire may also spread along extended surface materials such as carpets, wall linings and ceiling linings. With non-piloted ignition, the dominant means of occurrence is by radiant heat flux through one or more openings of the fire enclosure. An object will ignite when the imposed heat flux on it is sufficiently high and sustained. If the adjoining space is an enclosure, hot gases which escape from the fire enclosure will accumulate beneath the ceiling of the adjoining enclosure and contribute to the imposed radiant heat flux on the object.

Critical conditions for ignition of exposed materials are not defined in this section but guidance on appropriate criteria may be found in Section 8.2.2.

### **10.2.3 Routes of fire spread**

Fire spread beyond the fire enclosure takes place through paths created by openings in the boundaries of the fire enclosure. These are:

- (a) closures such as doors and windows which are in the open position;
- (b) openings resulting from breakage of glazed openings, including glazed openings in external walls causing fire to project outwards and heat the enclosure above;
- (c) openings from failure at penetrations of building services in barriers, due to:
  - (i) penetrations either inadequately or not firestopped;
  - (ii) breached services.
- (d) openings resulting from loss of integrity of the barrier, (e.g. walls, floors and closures in the closed position) due to structural collapse and/or cracks or fissures.

### **10.2.4 Factors influencing fire spread**

The likelihood of fire spreading beyond the fire enclosure is influenced by the components which are designed to control fire spread, such as fire-resisting barriers, suppression systems, fire dampers and air-handling systems (see Section 5.5). Other factors which are not directly accounted for and may significantly influence the likelihood of spread must also be considered where appropriate. These include:

- (a) ventilating a ventilation-controlled fire, such as opening doors or breaking windows in a continuously connected remote location, thereby creating a pressure differential for a through-draught situation to occur;
- (b) access to vertical shafts such as stairways, lift shafts and large service ducts which has the potential to exacerbate situation (a) above when other closures to the shafts are open or there is sufficient leakage in the shafts;
- (c) concealed spaces such as ceiling voids, spaces within hollow construction, under floors and under exterior cladding through which hot gases may spread undetected;
- (d) large open spaces with high ceilings, such as atriums and malls where fires tend to be fuel-controlled and occurrence of flashover is unlikely.

The first two factors have the potential to intensify the fire, particularly if the fire is highly ventilation-controlled. Alternatively, if the fire is not ventilation controlled, enhancing the ventilation to the fire may reduce the fire intensity by drawing away the hot gases. In either case, the likelihood of fire spread may be increased by these two factors. Factor (c) has the potential to preheat the internal spaces such that any combustible material within these spaces will ignite more readily when there is either sufficient heat or ventilation to do so. In factor (d), the large space and high ceiling mean that fire spread is more likely to occur due to direct radiation from the fire. Hence adequate control of fire spread in this situation may be achieved by providing sufficient separation between combustibles. Some guidance for achieving suitable separation is given in Section 5.5.

### **10.3 Use of Sub-system**

#### **10.3.1 General**

The flowchart presented in Figure 10.1 illustrates a procedure that may be followed to analyse the spread of fire beyond the fire enclosure as a function of time.

The fire at the preflashover stage has limited heat output and therefore may be readily withstood by the boundaries of an enclosure, including non fire rated interior partitions. For the purpose of this sub-system, fire spread beyond an enclosure need not be considered during the preflashover stage, unless it can be demonstrated otherwise.

#### **10.3.2 Spread Routes**

The location(s) of interest and the potential routes of spread should be defined during the FEDB. There may be more than one potential route for fire to spread for a given fire location and this may require several sets of analyses to be carried out. Section 10.2 provides guidance on the possible mechanisms which should be considered.

#### **10.3.3 Openings**

All possible openings must be considered in the analysis, including those which may develop during the course of the fire. Combinations of closure positions, for openings which may be either opened or closed, should be investigated to determine the worst likely conditions for fire spread. Assuming all closures to be initially open (or initially closed) may not result in the most severe fire. For glazed openings, the failure criteria must be known (see also Chapter 8) to determine the time of breakage.

#### **10.3.4 Barriers**

Barriers are effective in preventing the spread of fire primarily because of their capacity to shield potential combustibles against exposure to the effects of the fire. All barriers which form the enclosure boundaries have an inherent resistance to the effects of fire. The level of fire resistance which a barrier requires depends upon the level of fire severity that needs to be withstood. The required level of fire severity is determined on the basis of the design objectives that need to be satisfied as determined in the FEDB, and may be based on the following:

- (a) the most severe fire considered for its duration required for egress;
- (b) the most severe fire considered for its duration required for fire brigade intervention;
- or
- (c) the most severe fire considered for its entire duration.

The criteria for loss of integrity of the barriers must be known if the time of openings developing in the barriers past the preflashover fire stage needs to be determined.

### **10.3.5 Structural adequacy**

Barriers which are supported by structural elements, or are structural elements themselves supported by other elements, may also fail when the supporting element fails. Hence the time of failure of the structural element must be evaluated to ensure that the barrier it is supporting do not fail prematurely. If the analysis proceeds past the failure of the structural element, then the consequence of the failure of the element on other barriers (or elements) needs to be considered.

### **10.3.6 Application assumptions.**

The critical event for this sub-system corresponds to the occurrence at which a material outside the fire enclosure ignites and sustains burning. However, for the purpose of this analysis, the following simplifications may be assumed for determining the occurrence of the event for spread:

- (a) For spaces exterior to the fire enclosure which are connected by openings, such as doors and windows to the fire enclosure, the event may be assumed to correspond to the occurrence of flashover.
- (b) For spaces which are separated by imperforate barriers, the event may be assumed to occur when the barrier has failed.

For spaces which are connected by small and intermediate openings to the fire enclosure, the occurrence of fire spread is best evaluated by the consideration of ignition and sustained burning of any combustibles within that space.

In all cases, fire spread may still not occur if it can be demonstrated that the exterior combustibles do not ignite and sustain burning or that the exterior spaces do not have ignitable combustibles.

## **10.4 Inputs**

The following data should be included in the analysis:

- (a) **Characteristic Fire Profile.**  
The rate of heat release and time to flashover may be obtained from the fire profile determined in the Fire Initiation and Development sub-system (see Chapter 8).
- (b) **Enclosure Geometry.**  
The number and sizes of openings and dimensions of the fire enclosure may affect both the enclosure temperature and the extent of fire projection.
- (c) **Thermal characteristics of enclosure boundaries and structural elements.**  
These will affect the heat losses from the enclosure and the performance of structural elements and barriers.
- (d) **Environmental effects.**  
Wind velocity and direction may influence the extent of fire projection from windows and heat losses from the enclosure. The effect of wind is likely to be more significant when a through-draught condition exists.

## Chapter 10- Fire Spread and Management

Building location and adjacent combustibles. The proximity and ignition characteristics of combustibles in adjacent spaces, buildings or facilities should be taken into account in estimating the potential for fire spread.

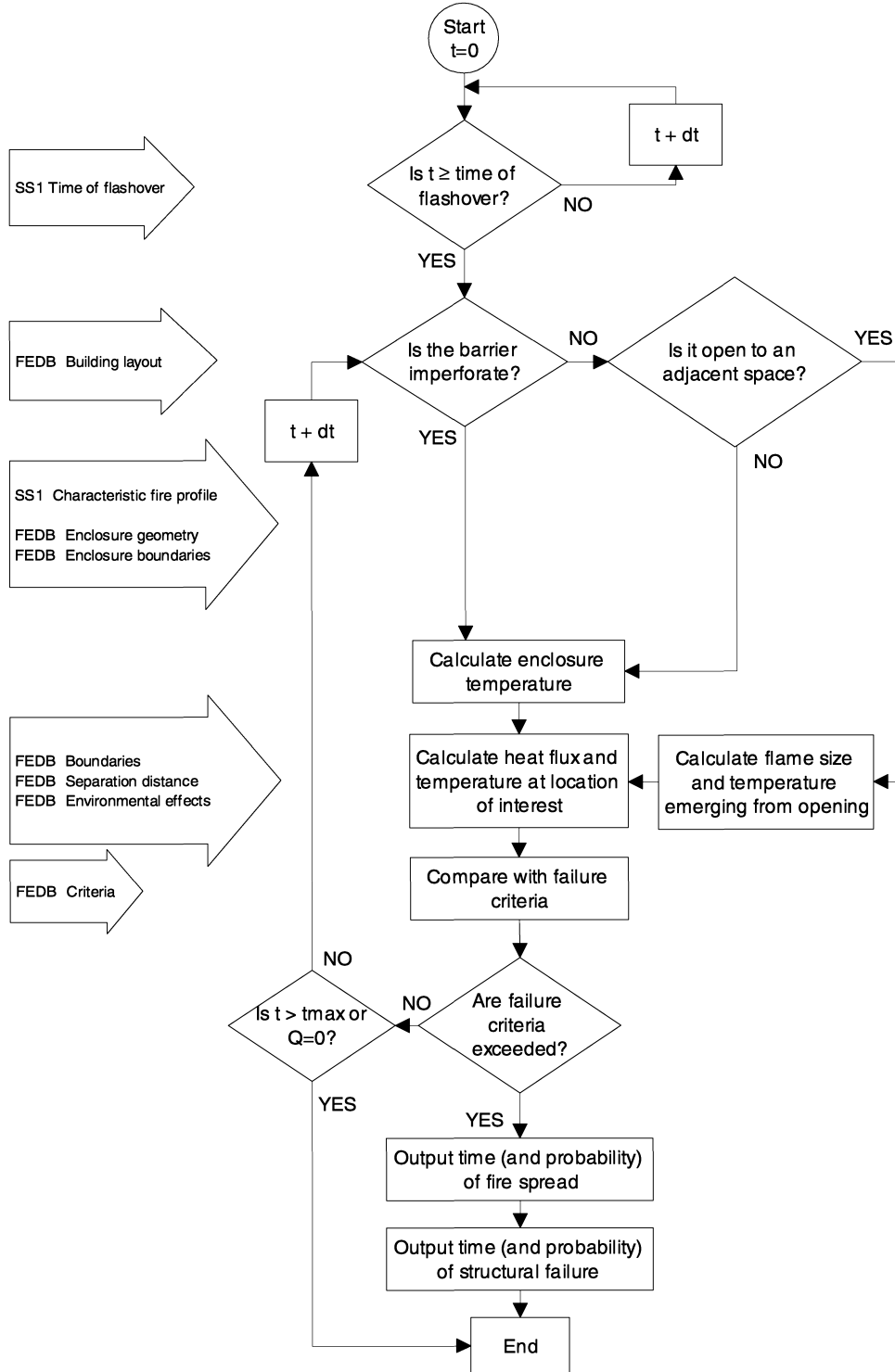

**Figure 10.1 Fire spread beyond enclosure boundaries**

### 10.5 Outputs

This sub-system provides a measure of the likelihood of a fire spreading beyond the enclosure boundaries. The following results are evaluated based upon the input determined in Section 10.4:

- (a) Time of fire spread.  
The critical event for this sub-system corresponds to the time of occurrence at which a material outside the fire enclosure ignites and sustains burning. The time for which this event occurs is evaluated for all three levels of analysis.
- (b) Probability of fire spread.  
For a Level 3 analysis, the probability of occurrence of this event, at the time it occurred, is also evaluated. Indicative failure probabilities for time independent events are provided in Table 10.1.

### 10.6 Analysis

**10.6.1 General.** The methodologies and equations presented are not exhaustive and alternative techniques may be used if they can be shown to be appropriate to the particular appraisal.

**10.6.2 Procedures.** The procedures described in the following sections provide means of calculating:

- (a) fire severity; and
- (b) fire spread.

Similar principles are utilized in calculating both fire severity and fire spread. These are outlined in Section 10.6.3. Results of the calculations may then be used to evaluate:

- (a) the performance of structural elements and barriers (including closures to openings) in the fire enclosure; and
- (b) the heat flux to a combustible surface outside the fire enclosure for initiation of ignition.

#### 10.6.3 Heat transfer principles.

##### 10.6.3.1 General

Some guidance on heat transfer calculations for fire conditions is given in Section 8. More detailed guidance is also available in a number of publications such as Drysdale (1985) and Section 1, Chapter 2 of the SFPE Handbook (1995).

##### 10.6.3.2 Transient heat flow

Since the process of fire development and decay produces a varying heat output, the thermal conditions occurring as a result of its influence are also transient in nature. A full analysis may therefore often require the solution of time-dependent partial differential equations.

### 10.6.3.3 Steady-state heat flow

Steady-state heat flow occurs when the temperature gradient within the material has settled down to a constant value. Lightweight materials tend to reach steady-state conditions earlier than dense materials. Though steady-state conditions are rarely achieved in building fires, a steady-state analysis can often be used as part of a simplified analysis provided that the underlying assumptions and initial conditions are conservative.

### 10.6.3.4 Conduction

Conduction expressed as a steady-state heat flux in one direction is given by equation(10.1):

$$\frac{dq_x}{dt} = k \frac{dt}{dx} \quad (10.1)$$

where

$q_x$  is the heat flux in the x-direction (in  $W m^{-2}$ );

$k$  is the thermal conductivity (in  $W m^{-1} K$ );

$t$  is the time (in s);

$x$  is the distance in the x direction.

Steady-state analysis can be considered the worst-case condition for most situations; it can be used to simplify several problems but will very rarely be attained in real fires.

Non-steady-state heat transfer equations may be used to examine fire behaviour such as ignition and fire spread, as well as the response of the building enclosure to developing fires. Equation (10.2) represents three-dimensional transient heat transfer. However, problems may be simplified to single dimensions to ease calculations, i.e. materials may be treated as infinite slabs or semi-infinite solids.

$$\frac{d^2T}{dx^2} + \frac{d^2T}{dy^2} + \frac{d^2T}{dz^2} = \frac{1}{h_a} \cdot \frac{dT}{dt} \quad (10.2)$$

where

$T$  is the temperature (in  $^{\circ}C$ );

$h_a$  is the thermal diffusivity (in  $m^2 s^{-1}$ ) (see equation(10.3));

$x,y,z$  represents the direction of heat flow.

$$h_a = k / (\rho C_m) \quad (10.3)$$

where

$k$  is the thermal conductivity (in  $W m^{-1} K^{-1}$ );

$\rho$  is the density of material (in  $kg m^{-3}$ );

$C_m$  is the specific heat capacity of the material (in  $J kg^{-1} K^{-1}$ )

Equation (10.2) can be solved for various boundary conditions using analytical or numerical techniques. Various computational procedures are available to solve equation

(10.2) and to evaluate the temperature gradients through constructions. These models generally use finite difference or finite element techniques and require detailed information on the change in thermal conductivity and other thermal properties as a function of temperature. The models are most suitable when applied to materials or forms of construction that are physically stable under fire conditions. Special care is needed with materials and systems that are likely to break down at high temperature.

Such procedures may be used as part of a study to evaluate:

- (a) the time to failure of loadbearing elements such as the primary reinforcement in concrete members;
- (b) the temperature of steel members protected with insulation materials;
- (c) the performance of steel/concrete members with complex shapes, such as shelf-angle floors, composite steel/concrete, etc.;
- (d) the temperature rise on the unexposed face of separating elements.

Further information on the calculation of temperature profiles in solid materials are described by Lie and Williams-Leiv (1979) and Lie (1992).

### 10.6.3.5 Convection

Equation (10.4) represents the heat flux from convective flow:

$$q_c = h_c (T_g - T_s) \quad (10.4)$$

where

$q_c$  is the convective heat flux (in  $W m^{-2}$ );

$h_c$  is the convective heat transfer coefficient (in  $W m^{-2} K^{-1}$ );

$T_g - T_s$  is the temperature difference between the gas and the solid surface (in K).

The convective heat transfer coefficient,  $h_c$ , can be difficult to quantify. It depends on the geometry of the solid surface, on the nature of the fluid flow (laminar or turbulent) and on the temperature difference. Guidance on the estimation of  $h_c$  can be found in Drysdale (1985) and this should be used to estimate the convective heat losses from the cold face of an element of construction. In fully developed fires the influence of convection on the hot-face heat transfer is small and for most purposes a design value of  $25 W m^{-2} K^{-1}$  may be utilised for  $h_c$ .

### 10.6.3.6 Radiation

The total radiative energy emitted by a body is proportional to  $T^4$ , where  $T$  is the temperature in Kelvin. The net heat flux being received by a remote surface is given by equation(10.5):

$$q_r = \phi \sigma \varepsilon (T_B^4 - T_s^4) \quad (10.5)$$

where

$q_r$  is the net radiative heat flux per unit area (in  $W m^{-2}$ );

$\phi$  is the configuration factor;

$\varepsilon$  is the emissivity of the surface;

- $\sigma$  is the Stefan-Boltzmann constant ( $5.67 \times 10^{-8}$  in  $W m^{-2} K^4$ )
- $T_B$  is the temperature of the radiator (in K);
- $T_s$  is the temperature of the receiving surface (in K).

Because the value of  $T_s$  is usually much smaller than  $T_b$ , its contribution becomes insignificant in equation (10.5) and is commonly ignored. The configuration (or view) factor is the geometric factor expressing the fraction of the radiant energy leaving the radiator that arrives at the receiver. The value of the factor depends on the size and distance of the radiating surface and the relative orientations of the radiator and receiver. The value varies from zero to unity (shielded to full view). Guidance on the calculation of configuration factors is given by Siegel and Howell (1981) and by Tien et al in Section 1, Chapter 4 of the SFPE Handbook (1995). Typical applications of configuration factors in determining ignition of remote combustible materials due to radiation is given in Appendix 10A.

### **10.6.4 Fire severity.**

#### **10.6.4.1 General**

For the purpose of evaluating the performance of structural elements and barriers, fire severity is measured in terms of the temperature- or heat flux- time profile in the enclosure. The peak value and the duration of the peak in the temperature- or heat flux- time profile are important parameters for consideration of the performance of the barrier or structural element. The procedures for determining the temperature- or heat flux- time profile may be categorized into:

- (a) mathematical procedures; and
- (b) full-scale or near-full-scale experiments.

#### **10.6.4.2 Mathematical procedures**

##### **10.6.4.2.a Basic heat balance**

When used to analyse fire severity, mathematical models must at least take the following into consideration:

- (a) rate of heat loss by radiation through openings;
- (b) rate of heat loss by convective flow through openings (including cooling of the hot gases by incoming air);
- (c) rate of heat loss by radiation and convection to the enclosing boundaries;
- (d) rate of accumulation of heat in the hot gases of the enclosure.

These factors constitute the minimal basis for evaluating the temperature-time profile using a heat balance approach, although (d) is usually ignored in simpler models. All of these factors represent heat losses from the energy released from the fire as derived in Chapter 8. The expressions given in Section 10.6.3 may be used to calculate the heat loss factors. Pettersson et al (1976) has used such an approach to derive temperature-time curves as a function of fire load and ventilation conditions for a fire compartment.



### 10.6.4.2.b Computer modelling.

Computer models provide convenient means of analysing the effects of fire in an enclosure. Important factors governing the predictive capabilities of computer models include the level of the assumptions and simplifications of the physical and chemical processes that constitute the models and the data used for the models. Guidance on procedures available for demonstrating the validity and accuracy of predictive models can be found in ISO/TR 13389 - Fire safety engineering: Assessment and verification of fire calculation models. Care must be exercised with the choice of data, particularly those which vary with temperature. The accuracy and significance of the input data may be assessed by carrying out analyses on the sensitivity of the computer model predictions to variations in the input data.

The two types of computer models for fire analysis, i.e. zone models and field models, are described in some detail in Appendices 9A and 9B. These models should account for the factors outlined in 10.6.4.2.1. More sophisticated models (as found in more advanced zone models and field models) may also take the following into account:

- (e) vitiation effects on combustion;
- (f) rate of release of unburnt pyrolyzates in a ventilation controlled environment;
- (g) effect of radiation feedback on the combustion rate.

### 10.6.4.2.c Simplified relationships.

A number of simplified empirical relationships for predicting fire severity have been developed, particularly for the evaluation of structural adequacy of members in fire. However, many of these relationships only consider factors (a) and (b) in Section 10.6.4.2.1 and a few may consider factor (c). These simplified relationships have been developed to provide an alternative means of relating real fires to the standard temperature-time curve, although they are based on wood crib tests on 'standard' enclosures. Among the more reliable ones is the approach prepared by CIB W14 (1986):

$$t_{\text{eqv}} = cwq_f$$

where

$t_{\text{eqv}}$  is the equivalent time of fire exposure to the standard test (in min);

$c$  is a conversion factor which relates to the thermal properties of the enclosure boundaries by means of the thermal inertia  $\sqrt{\lambda\rho c_p}$ , where  $\lambda$  is the thermal conductivity (W/m/K),  $\rho$  is the density ( $\text{kg/m}^3$ ) and  $c_p$  is the specific heat (J/kg/K). Recommended values are:

$c$ (min/(MJ/m <sup>2</sup> ))	$\sqrt{\lambda\rho c_p}$ (Ws <sup>1/2</sup> /(m <sup>2</sup> K))
0.09	<700
0.07	700...2500
0.05	>2500

$w$  is a dimensionless ventilation factor which allows for the profile of the opening

$$= \frac{A_f}{(A_t A \sqrt{h})^{1/2}}$$

where

$A_f$  is the floor area of the enclosure ( $m^2$ )

$A_t$  is the total interior surface area of the enclosure including openings ( $m^2$ )

$A$  is the total area of the door and window openings ( $m^2$ )

$h$  is the average height of the openings weighted with respect to each individual opening area (m)

and

$q_f$  is the fire load density, for all fire loads which may contribute to the fire process ( $MJ/m^2$ )

### **10.6.4.3 Full-scale or near-full-scale experiments**

Various full-scale or near-full-scale experiments have been performed using timber cribs (Butcher et al (1966), Anon (1968)) and other typical materials in realistic compartments, e.g. studies on cars in car parks carried out in countries including the UK (Butcher et al (1967)), the USA (Gewain (1973)), and Australia (Bennetts et al (1985,1988)), and Australian studies on office fires (Thomas et al (1989a, 1989b, 1992)). These and similar experiments provide background information that may be used in comparable situations for determining fire severity.

### **10.6.4.4 Structural performance**

The limit state of failure is reached when the loadbearing capacity of the structural element, frame or assembly decreases under fire conditions to a level at which it can no longer support the load acting on the structure. The criteria for structural failure, including structural material properties at elevated temperatures, should be determined from guidance given in the relevant Australian Standards:

- (a) AS 1720 for timber members;
- (b) AS 4100 for steel members;
- (c) AS 3600 for concrete members;
- (d) AS 3700 for masonry.

Load factors differing from those used for normal design purposes may be adopted to calculate the loads applied to the members at the fire limit state. Certain structural materials behave as an assembly of components, and loss of loadbearing capacity for one element may not lead to failure of the structure.

Guidance on the insulation and integrity criteria for components of the building enclosure is given in AS 1530, Part 4. In some circumstances the criteria set in standards such as AS 1530, Part 4 may not be applicable to the appraisal in question. In these cases criteria appropriate to the particular situation should be developed during the FEDB.

Unless appropriately trained, the role of fire safety engineers should be limited to predicting the thermal effects of the fire on structural elements. Structural engineers can

then use the corresponding material properties to predict the behaviour of the structural element at elevated temperatures.

### **10.6.5 Fire spread.**

#### **10.6.5.1 General**

For the purpose of evaluating the heat flux to a combustible surface outside the fire enclosure for initiation of ignition, the dominant mode of heat transfer is radiation for discrete combustibles. Refer to Chapter 8 for guidance on flame spread over extended surfaces such as floor coverings.

#### **10.6.5.2 Fire size and temperature**

In order to calculate the effects on fire spread of heat transfer from fires, by either radiation or direct fire impingement, it is essential that the shape, size and temperature profile of fires and horizontal projection from the opening should be determined. The fire height and horizontal projection from the opening can be calculated, as can the temperatures at any point along the fire. Guidance on the calculation procedures is given by Law and O'Brien (1981) and AISI (1983), though only those parts relating to fire properties need be used. These calculation methods were principally developed to quantify the nature of fires emerging from external windows but can also be used for fires emerging from internal openings such as doors.

#### **10.6.5.3 Fire spread to adjacent buildings**

Guidance on the general principles and methods for evaluating separation distances between buildings can be found in Read (1991). This document includes tables on acceptable areas of openings for various types and sizes of building. The separation distances are based on a method originally published in 1963 by Law for estimating the intensity of heat radiation emitted from window openings, and the received intensity incident on nearby receiving surfaces.

#### **10.6.5.4 Radiation and flying brands**

BS 476 : Part 3 is the method of test normally used to assess the ignitability and fire spread characteristics of external surfaces of roofs when subjected to radiation from a fire in an adjacent building and pilot ignition from flying brands. It is often difficult to establish, with any certainty, the distance that a burning brand rising in the thermal plume may be carried in the wind. The design should essentially ensure that a roof covering is not subjected to radiation levels sufficient to make it susceptible to pilot ignition by burning brands.

#### **10.6.5.5 Fire Spread in Large Enclosures**

The relationships for enclosure temperatures given in Section 10.6.3 are based on experiments in enclosure sizes with floor areas of approximately 10 m<sup>2</sup> or less, although some of the relationships have also been shown to compare well with experiments in floor areas of up to 50 m<sup>2</sup> (see Latham et al (1987)). These experiments are often conducted by igniting the fuel (usually wood cribs) simultaneously without accounting for the growth period and the time for the fire to spread. Ignoring the growth period is conservative because the heat loss during this period is also ignored. When considering large open plan enclosures (>150 m<sup>2</sup>), typical of modern office floor layouts, the time for fire to spread

## Chapter 10- Fire Spread and Management

to the rest of the enclosure becomes significant relative to the duration of the fully developed stage of a localised fire. If simultaneous burning is assumed for enclosures with large floor areas, unrealistically high temperatures in the enclosures will be obtained.

Fire spread is still being actively researched and presently lacks good predictive methods in convenient formulations. Careful use of good engineering judgement is therefore necessary in order to produce realistic predictions. Estimates of fire spread rates may be evaluated from large open plan office enclosure fires (see Thomas et al (1992a) and Nelson (1989)). As a first approximation, the design fire for large enclosures may be approximated by dividing the floor area into grids of 10-50 m<sup>2</sup> and then constructing an overall heat release rate by integrating the heat release rate for each grid with appropriate time offsets estimated for the fire to spread from one grid to the next. The enclosure temperatures can then be predicted with an appropriate fire model, using the integrated heat release rate as input. If the type and arrangement of the combustibles are known, then better estimates of the spatial development of the fire can be made based on ignition criteria and heat release rates of the individual objects.

**Table 10.1. Maximum Values for Probabilities without Appropriate Calculation**

Component	Conditions	Probability of Operation	
		Non-flashover	Flashover
Barriers	Without nominated Fire Resistance Rating and no opening	0.80	0.50
	With nominated Fire Resistance Rating and no opening	0.95	0.95
	Without nominated Fire Resistance Rating and openings without automatic closers	0.60	0.30
	With nominated Fire Resistance Rating and openings with automatic closers	0.90	0.90

### References

AISI (1983), Fire Safe Structural Steel - A Design Guide.

Anon (1968), Behaviour of structural steel in fire, Symposium No. 2, London, HMSO.

BENNETTS, I.D., LEWINS, R.R., PROE, D.J., THOMAS, I.R., DOWLING, V.P., RAMSEY, G.C., SCHAFER, B.L., and LACEY, R. (1988), Fire in Unprotected Steel Enclosed Car Parks, BHP Melbourne Research Laboratories Report MRL/PS98/87/001. BHP Steel International.

BENNETTS, I.D., PROE, D.J., LEWINS, R., and THOMAS, I.R. (1985), Open deck Car Park Fire Tests, BHP Melbourne Research Laboratories Report MRL/PS69/85/001. BHP Steel International, August.

BUTCHER, E.G., CHITTY, T.B., and ASHTON, L.A. (1966), Time temperature attained by steel in building fires. Fire Research Technical Paper No 15, London, HMSO.

BUTCHER, E.G., LANGDON-THOMAS, G.J., and BEDFORD, G.K. (1967), Fire in the Motor Car. Results of the Tests on the Propagation of Fire in Parked Cars, Fire Research Note No. 678, JFRO, October.

CIB W14 (1986), Design Guide Structural Fire Safety Workshop, Fire Safety Journal, 10 (2).

DRYSDALE, D. (1985), An Introduction to Fire Dynamics, Chichester, John Wiley and Sons.

## **Chapter 10- Fire Spread and Management**

GEWAIN, R.G. (1973), Fire Experience and Fire Tests in Automobile Parking Structures. Fire Journal, July, pp. 50-54.

Latham, D.J., Kirby, B.R. and Thomson, G. (1987), The Temperatures Attained by Unprotected Steelwork in Experimental Natural Fires, Fire Safety Journal, 12.

LAW, M. (1963), Heat Radiation from Fires and Building Separation, Fire Research Technical Paper No. 5, London, HMSO.

LAW, M., and O'BRIEN, T. (1981), Fire Safety of Bare External Structural Steel, Steel Construction Institute,.

LIE, T.T. (1992), The American Society of Civil Engineers, Manual and Reports on Engineering Practice No. 78, Structural Fire Protection.

LIE, T.T., and WILLIAMS-LEIV, G. (1979), Factors Affecting Temperature of Fire Exposed Concrete Slabs, Fire and Materials, June, Vol. 3, No. 2, pp. 74-79.

Nelson, H. E., An Engineering View of the Fire of May, 1988 in the First Interstate Bank Building, Los Angeles, California, NISTIR 89-4061, 1989.

PETTERSSON, O., MAGNUSSON, S.E., and THOR, J. (1976), Fire Engineering Design of Steel Structures, Swedish Institute of Steel Construction, Publication No. 50.

READ, R.E.H., (ed.) (1991), External Fire Spread : Building Separation and Boundary Distances, BRE Report 187, Building Research Establishment.

Siegel, R. and Howell, J. R. (1981), Thermal Radiation Heat Transfer, Hemisphere Publishing Corporation, New York, second ed.

The SFPE Handbook of Fire Protection Engineering (1995), Second Edition, Quincy, Massachusetts, NFPA.

THOMAS et al (1992), Fire Tests of the 140 William Street Office Building, BHP Research, Melbourne, Australia.

THOMAS, I.R., ALMAND, K.H., BENNETTS, I.D., PROE, D.J. and LEWINS, R.R. (1989b), Fire in Mixed Occupancy Buildings, BHP Melbourne Research Laboratories, Report No MRL/PS69/89/004, August.

THOMAS, I.R., BENNETTS, I.D., PROE, D.J. AND LEWINS, R.R. (1989a), Fire in Offices, BHP Melbourne Research Laboratories, Report No MRL/PS69/89/005, August.

TIEN, C.L., LEE, K.Y., and STRETTON, A.J. (1995), Radiation Heat Transfer, The SFPE Handbook of Fire Protection Engineering, Section 1, Chapter 4, Quincy, Massachusetts, NFPA.

## Chapter 11 - Fire Detection and Suppression

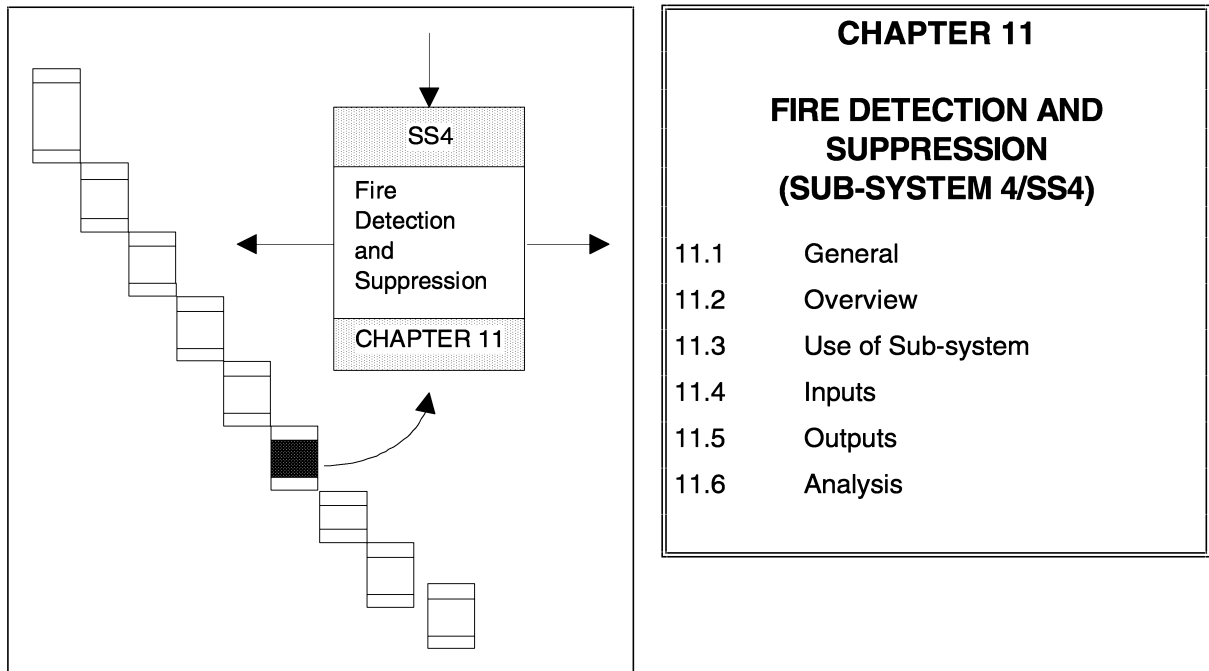

### 11.1 General

This Chapter provides the basis for calculation of the following :

- (i) activation of fire detectors, including sprinkler activation.
- (ii) effectiveness of automatic fire suppression equipment.

The activation of fire detection elements may be used to initiate

- fire suppression action
- occupant evacuation
- smoke control activation
- fire brigade response

Fire suppression action may also affect the fire growth rate and therefore there is a strong link between this sub-system SS4 and the fire development in SS1.

### 11.2 Overview

#### 11.2.1 General

This section outlines the definitions, concepts and principles that should be understood by the fire engineer in order to calculate the time and probability of fire detection and suppression.

Delays between detector response and commencement of smoke management, suppression and fire fighting activities are identified.

Their estimation may be important in many fire engineering designs.

## **Chapter 11 - Fire Detection and Suppression**

### **11.2.2 Fire Detectors**

#### **11.2.2.1 General**

The prediction of activation times of a fire detector requires knowledge of the rate of fire growth (eg. flame size, temperature, smoke profiles, and heat release rate), characteristics of the automatic fire detector and details of the building geometry.

It should be recognised that a sprinkler head is a heat sensitive element and as such, behaves very similarly to a heat detector that forms part of a fire alarm system.

Guidance on the selection and installation of fire detection systems is given in AS1670 and for sprinklers in AS2118, and reference should be made to these standards when considering the most appropriate hardware for a particular application.

#### **11.2.2.2 Fire Detector Types**

The following types of detector are covered in this sub-system:

- (a) heat detectors, both fixed temperature (static) element detectors and rate-of-rise-of-element detectors, including sprinkler heads;
- (b) smoke detectors, i.e. ionization chamber smoke detectors, optical scatter smoke detectors, optical obscuration (beam) smoke detectors, and aspirating (or sampling) smoke detectors;
- (c) flame detectors, i.e. ultra-violet flame detectors and infra-red flame detectors.

#### **Heat Detectors**

Heat detectors, including sprinklers, respond to heat transfer from the ceiling jet as illustrated in Figure 11.1. Response is dependent upon the temperature and velocity of the ceiling jet at the detector location, as well as the detector characteristics. Designers should be aware that the temperature and velocity of the ceiling jet is not uniform and that the distance of the heat sensitive element down from the ceiling is an important parameter controlling detector response time.

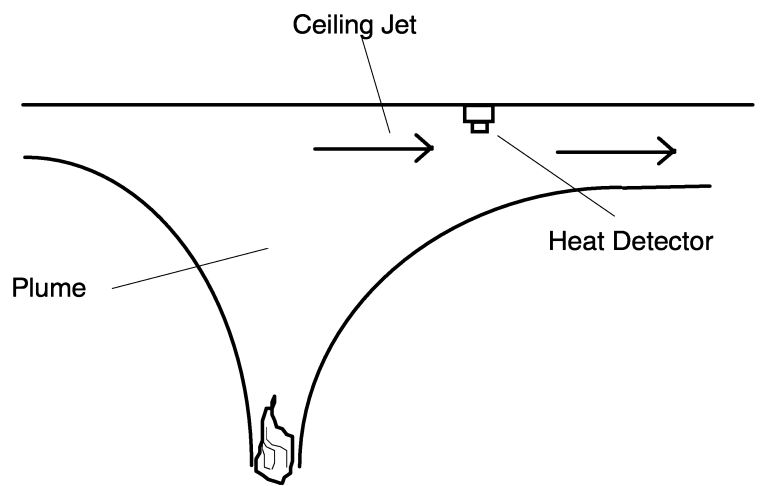

**Figure 11.1 Heat transfer from ceiling jet**

## **Chapter 11 - Fire Detection and Suppression**

### **Point Type Smoke Detectors**

The response of point-type smoke detectors (ionisation or optical) cannot be so easily modeled as that of heat detectors since their operation is a function not only of the optical density of the smoke but also of:

- (i) the size distribution of smoke particles produced;
- (ii) the light-scattering properties of the smoke particles (optical detectors);
- (iii) effect on ionisation chamber (ionisation detectors).

Ionisation detectors tend to be most sensitive to high concentrations of small particles such as those produced by flaming paper and wood fires, and least sensitive to the low concentration of large smoke particles produced in smouldering fires. Optical detectors, by contrast, have a high sensitivity to large smoke particles with diameters approximately equal to the wavelength of light, and low sensitivity to much smaller particles.

However, for point-type smoke detectors conforming to AS1603.2, specified minimum levels of sensitivity to a range of test fires are required. These test fires are described in various parts of AS2362.

### **Beam Type Smoke Detectors**

Beam detectors will give an alarm when the beam is attenuated by a given quantity of smoke. This is often expressed as a smoke obscuration, that can be converted into optical density terms. Like point type smoke detectors, the response is dependent on smoke characteristics, including particle size.

### **Aspirating Smoke Detectors**

An aspirating detector system is one in which air is normally drawn through a pipework system and sampled at a central point by a sensitive light scattering detector. For analysis purposes each sampling point can be modelled as an imaginary point detector.

The response level of aspirating detectors to optical smoke density can be individually set for each installation; they are often up to 10 times as sensitive as point-type detectors.

### **Flame Detectors**

A flame detector can be considered as a point receiving radiation emitted from a flame responding to a specific flame temperature and emissivity. The intensity of radiation received may be calculated using the procedures described in sub-system 3 (Section 10).

The sensitivity of a flame detector can vary according to the direction of the received radiation, and the off-axis sensitivity should be considered in the design process.



## **Chapter 11 - Fire Detection and Suppression**

### **11.2.2.3 Time Delays**

Time delays associated with the operation of fire detectors and the signalling of alarms must be identified by the fire engineer. These delays may include :

- the time taken for the fire to produce the conditions required for the operation of the detector.
- the delay associated with the transfer process from the localised area around the detector into the detector sensing mechanism (eg. thermal lag associated with response time index (RTI) of sprinklers).
- time delays associated with detector signal interrogation, confirmation and processing.
- the time of signalling of the alarm.

Detection systems are often used to activate other sub-systems and there may be further delays that should be recognised by fire engineers. These include :

- time to activation of suppression systems, including time for coincident detector operation and evacuation time delays set for gaseous and other special hazard fire suppression systems.
- time to activation of smoke management sub-systems, including delays in signalling, fan start up, damper/vent operation and door closure.
- time to notification of the fire brigade.

### **11.2.3 Automatic Suppression**

#### **11.2.3.1 General**

These Guidelines address a range of automatic suppression systems that may be activated by fire sensing elements (detectors/sprinklers) or other means.

Given activation, the effectiveness of automatic suppression systems in fire control or extinguishment, as may be expressed in the reduction of heat release rate with time, is the objective of this section.

There is a natural feedback from this sub-system into SS1 so that the characteristic fire profile can be modified to reflect the activation of an automatic suppression system.

Guidance on the selection and installation of automatic fire suppression systems is provided in standards such as AS 2118 and AS 4314.

#### **11.2.3.2 Automatic Suppression Types**

These Guidelines principally address two automatic suppression types as follows:

- automatic sprinklers, particularly standard response, fast response and special types such as ESFR and large drop sprinklers.
- gaseous suppression systems, including chemical type and inert gas type agents.

There are other specialised suppression agents such as :

## Chapter 11 - Fire Detection and Suppression

- fire fighting foams
- aerosol agents
- water mist

These specialised systems have not been explicitly considered in these Guidelines, but the same engineering principles apply for these types of suppression mechanisms as do for sprinklers and gaseous systems.

An important concept that needs to be understood by the designers is the one illustrated in Figure 11.2 below. Suppression systems may reduce the rate of heat release growth, may control the fire (heat release rate remains constant), or may suppress and extinguish the fire by reducing the heat release to zero.

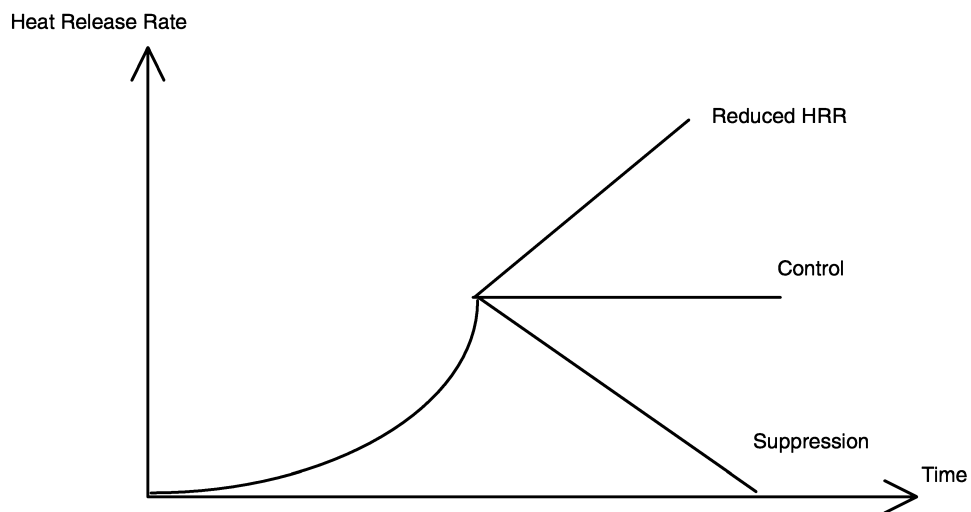

**Figure 11.2 Effect suppression systems on fire**

The designer must assume one of these options and take a more conservative approach unless specific information or calculations are available to support a less conservative approach.

### **11.2.3.3 Time Delays**

The time delays before activation (i.e. initiation of suppression agent delivery) have been identified under the detection clause 11.2.2.3.

In addition, there may be time delays before sufficient suppression agent is delivered through the delivery system, into the fire environment and onto the fuel to cause the heat release rate to be affected.

Designers need to make a reasonable estimate of these time delays.

## **11.3 Use of Sub-system**

### **11.3.1 General**

Due to the quite different activities of detection and suppression, sub-system use and appropriate schematics have been broken up into 2 parts to cover:

## **Chapter 11 - Fire Detection and Suppression**

- fire detection
- automatic suppression

### **11.3.2 Fire Detection**

The flow chart presented in figure 11.3 is intended to show the general principles that can be applied to all methods of detection.

Generally, the location(s) of interest will be defined during the FEDB (see Chapter 5); this will normally be a detector point or a zone.

For coincidence detection systems, two or more detectors are required to operate before full alarm is recognised. Such a system may depend upon the activation of either two similar detectors at different locations or two dissimilar types of detectors before the signal is confirmed.

### **11.3.3 Automatic Suppression**

The flow chart in figure 11.4 illustrates the procedures that should be applied to evaluate the performance of automatic suppression equipment.

Inputs are required from the fire detection analysis section of this sub-system on the activation time of suppression equipment.

Analysis of fire suppression performance may be required at a range of locations or enclosures.

The outputs from this analysis include the time and probability of control/extinguishment and the effect on the heat release rate that must be transferred back to SS1.

## **11.4 Inputs**

### **11.4.1 General**

Separate inputs are provided for :

- fire detection
- automatic suppression

### **11.4.2 Fire Detection**

#### **11.4.2.1 Automatic detector characterisation**

Information is required on the type, location and response characteristics of the detectors.

#### **11.4.2.2 Human characterisation**

The ability of the occupants to detect the fire should be established as far as possible in the FEDB (see Chapter 5).

## Chapter 11 - Fire Detection and Suppression

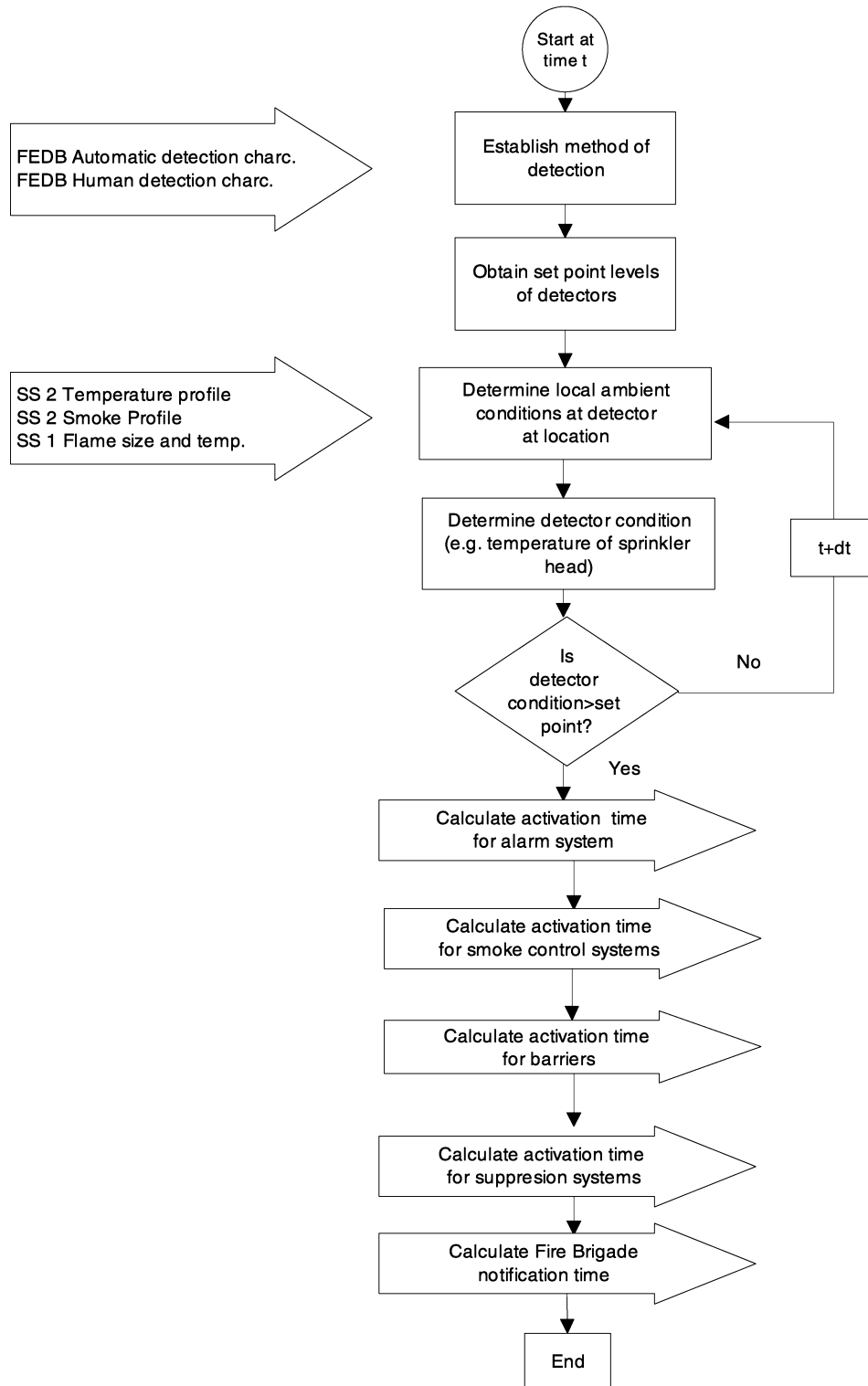

Figure 11.3 Automatic Detection and Suppression

# Chapter 11 - Fire Detection and Suppression

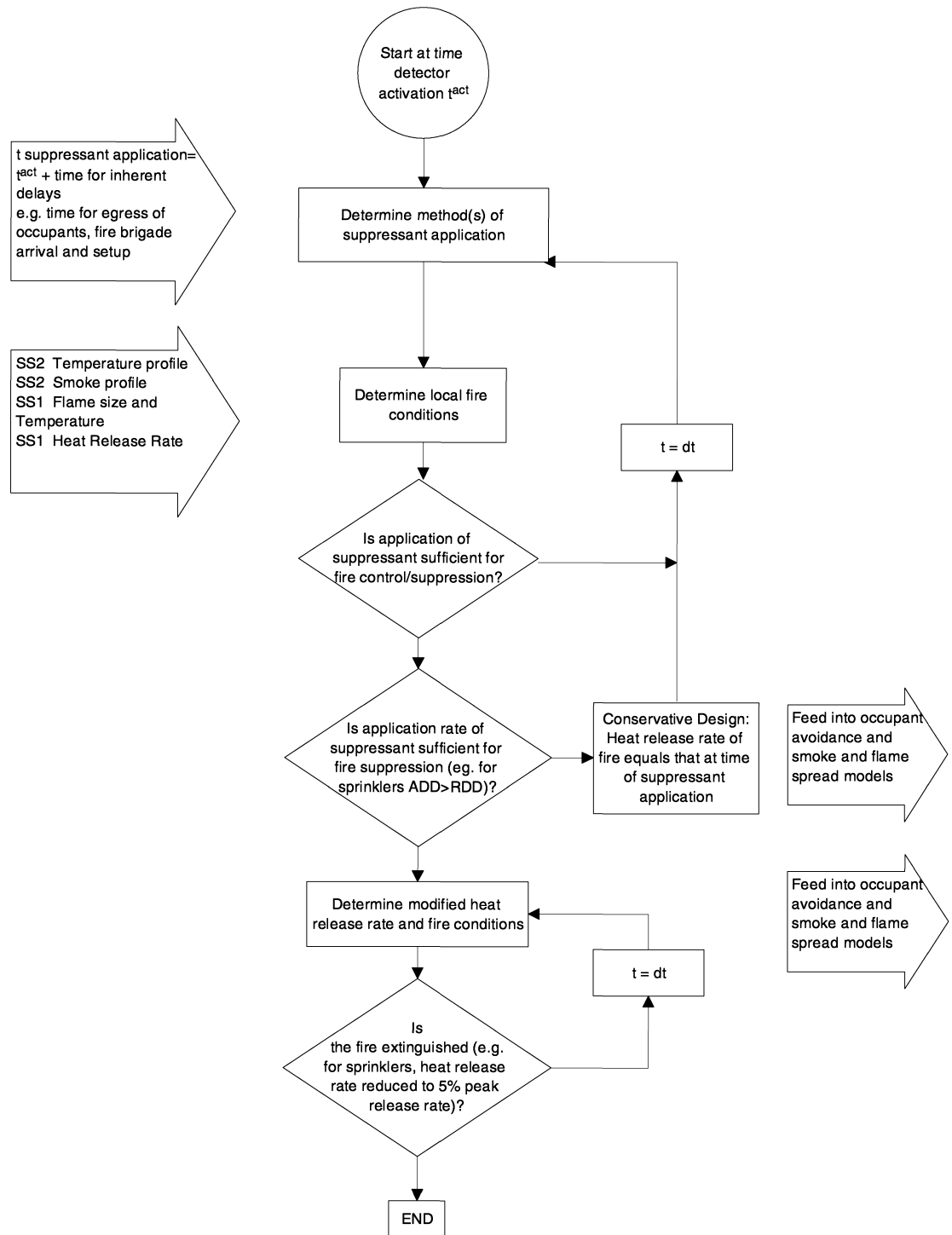

Figure 11.4 Flow chart for fire suppression systems

## **Chapter 11 - Fire Detection and Suppression**

### **11.4.2.3 Temperature profile**

This may be derived from sub-system 2 (see Chapter 9) as a time/temperature history at the detector location. The data then may be used to calculate the heat transfer to a heat sensing element.

### **11.4.2.4 Smoke profile**

This is a description of the optical density at the detector location and may be derived from sub-system 2 (see Chapter 9).

### **11.4.2.5 Velocity of smoke**

The smoke velocity may be required for detailed calculations of heat transfer to the sensing element as well as determining the transport time to the detecting element

### **11.4.2.6 Flame size**

The size of a flame and its temperature can be derived from the procedures described in sub-system 1 (Chapter 8). This may be used to calculate the heat flux incident upon a detector.

### **11.4.2.7 Heat release rate of the fire**

The heat release rate of the fire is a necessary input into many of the available computer programs and hand calculation techniques. If a quasi-steady state of the growing fire is to be assumed the smallest possible time interval between heat release rate data points should be chosen for the input. This input may be obtained from Sub-system 1 (Chapter 8).

## **11.4.3 Automatic Suppression**

### **11.4.3.1 Automatic Suppression characterization**

Information on the supply, distribution and initiation of the fire suppression system is required to estimate suppression effectiveness.

### **11.4.3.2 Activation Time**

The time to activation of the automatic suppression is required. This time comes from the detection part of this sub-system (SS4).

### **11.4.3.3 Heat Release Rate**

Suppression effectiveness is going to be dependent upon the rate of heat release at the time of release of the suppression agent. (Refer to SS1 - Chapter 8).

## **Chapter 11 - Fire Detection and Suppression**

### **11.5 Outputs**

#### **11.5.1 General**

Separate outputs are provided for :

- fire detection
- automatic suppression

#### **11.5.2 Fire Detection**

##### **11.5.2.1 General**

The outputs from the fire detection section of this sub-system serve as inputs to other parts of this sub-system (SS4) and to other sub-systems.

##### **11.5.2.2 Alarm Activation Time**

The predicted activation time for alarms should include any time equipment delays. The time will provide the time for occurrence of Cue A in sub-system 5 (SS5).

##### **11.5.2.3 Activation Time for Automatic Suppression**

The activation time is for the initiation of automatic suppression equipment as calculated in this sub-system (SS4), including any coincidence and evacuation time delays required before suppression agent discharge.

##### **11.5.2.4 Activation Time for Smoke Management**

This time is the point at which smoke management equipment starts to be effective and therefore includes all electrical and mechanical time delays. It provides input to SS2.

##### **11.5.2.5 Activation Time for Fire Brigade**

The time is the point at which the Fire Brigade is notified by an automatic detection system on a building fire alarm. It provides input to analysis of fire brigade effectiveness in sub-system 6 (SS6).

##### **11.5.2.6 Probabilities**

Where possible, probabilities for each of the above activation times should be provided as inputs into scenario timeline analysis and evaluation (Chapter 6).

#### **11.5.3 Automatic Suppression**

##### **11.5.3.1 Time to Control or Extinguishment**

Depending on the nature of the suppression system, the output will be time to control the fire (ie. prevent the heat release rate increasing) or to extinguish it. This provides input to SS1.

## Chapter 11 - Fire Detection and Suppression

### 11.5.3.2 Modified Heat Release Rate

The action of the suppression system will be to modify the characteristic fire profile, and the modified heat release rate will be part of a feedback loop as input to SS1.

## 11.6 Analysis

### 11.6.1 General

The methodologies, equations and input data presented are not exhaustive. Use of alternative approaches and data are encouraged, provided they can be technically justified by the designer and referenced from appropriate literature sources.

Generally, parameter values presented in this section represent "worst credible" conditions, unless otherwise stated. Where specific data is available, then it may be used, adopting a generally conservative approach.

### 11.6.2 Fire Detection

#### 11.6.2.1 Heat Detectors

The time of detection for heat detectors may be determined by hand calculations or computer models based on some original calculations by Alpert (Alpert: 1972), Delichatsios (Hekestad and Delichatsios: 1978) and other researchers.

##### (i) Hand Calculations

The basic response equation for a heat sensing device (whether heat detector or sprinkler head) is given by the lumped mass heat transfer equation as follows:

$$\frac{dT_d}{dt} = \frac{U^{1/2}(T_g - T_d)}{RTI} \quad (11.1)$$

where  $T_d$  is the detector temperature (°C)  
 $U$  is the instantaneous velocity of fire gases ( $\text{ms}^{-1}$ )  
 $T_g$  is the temperature of the fire gases (°C)  
 $RTI$  is the response time index ( $\text{m}^{1/2}\text{s}^{1/2}$ )  
 $t$  is time (sec)

In order to determine the detector operating time  $t_{op}$ , ie. when  $T_d$  reaches the detector operating temperature, the changing values of  $T_g$  and  $U$  with time must be known at the detector location. This requires information about the fire heat release rate, entrainment coefficients, ceiling height, radial distance from the plume to the detector location in order to predict  $T_g$  and  $U$  in the ceiling.

Alpert (Alpert: 1972) developed correlations, as did Heskestad and Delichatsios (Heskestad and Delichatsios: 1977) that can be used to hand calculate the time to heat detector operation. Generally the equations of Heskestad and Delichatsios will predict greater temperatures and velocities than those of Alpert and therefore are less conservative.



## **Chapter 11 - Fire Detection and Suppression**

Designers should be aware that these equations are based on some fundamental assumptions of :

- flat smooth ceilings
- unconfined gas flow
- strong plume (flaming) fires
- axisymmetric plumes (not near walls or corners)
- heat sensitive element in the peak velocity/temperature region of the ceiling jet.

### **(ii) Partially Confined Ceilings and Corridors**

Where the flow of gases is partially confined to form a channel by ceiling beams or walls as in a corridor the equations of Delichatsios (Delichatsios: 1981) could be used to establish the temperature of the gas flow:

Those equations still assume that no significant gas layer has developed prior to activation of the detector. For smaller rooms or long activation times where the Delichatsios equation may not be the valid the equations of Evans (Evans: 1984) or Cooper (Cooper: 1984) could be used to determine a substitute fire source and heat release rate.

### **(iii) High Ceilings**

When using  $t^2$  design fires and large areas such as atria, the temperature rise of the smoke layer required for activation above the activation temperature of the sprinkler at a radius to ceiling height ratio of less 0.6 can be estimated using the values in Table 8.5.2 (NFPA 92B: 1991) and;

$$\Delta T = 2090 \left[ \left( \frac{t}{t_g^{2/5} H^{4/5}} \right) - 0.57 \right]^{4/3} \left/ \left[ t_g^{4/5} H^{3/5} \right] \right. \quad (11.2)$$

Where;

$\Delta T$  is the temperature rise at the ceiling ( in °C)

$t_g$  is the time taken for the fire to reach 1055 kW

### **(iv) Computer Models**

A number of specific computer models exist that can be used to predict the time of activation of heat responsive elements such as heat detectors and sprinklers. These programs include DETACT - QS, FPETOOL, SPRINKLER, and LAVENT. The programs should only be used within their limitations or the reasoning behind going beyond those limitations should be justified.

It is important to understand the physics of the computer models and the assumptions built into each code:

DETECT-QS, SPRINKLER and FPETOOL are each based on experimental correlations developed by Alpert for steady state fires. These correlations provide the maximum temperature and velocity for the ceiling jet and assume that the detector element would be located within the above area, and a smooth

## Chapter 11 - Fire Detection and Suppression

unconfined ceiling. To model growing fires they use a quasi-steady state approach that assumes the fire would be constant over small time intervals. The accuracy of the solution would therefore in part depend on the time interval chosen for the inputs. None of the programs take into account the transport time for the smoke and hot gases from the fire to reach the detector and if this time were significant it would have to be added to the detector activation time calculated by the program.

FPETOOL accounts for the impact of the hot gases entrained into the ceiling jet on the temperature and velocity of the jet as it passes through the hot gas layer, DETACT-QS and SPRINKLER do not.

LAVENT is used to simulate the environment and response of sprinklers in compartment fires with draft curtains and ceiling vents. LAVENT also uses a quasi-steady state approach to model growing fires and ignores the transport time of the hot gases to the detector location. LAVENT like FPETOOL does account for the impact of the upper hot gas layer on the ceiling jet but it also accounts for the location of the detector head below the ceiling in the ceiling jet. (It can not model recessed sprinkler heads).

The required inputs for the various programs are as shown in table 11.1. The most appropriate program in terms of the available inputs data and area of application should be used.

**Table 11.1 Input variables required for various computer programs**

Required Inputs	DETECT-QS	FPETOOL	SPRINKLER	LAVENT
Height Ceiling above Fuel	X	X	X	X
Distance of Detection from axis of fire	X	X	X	X
Initial room temperature	X		X	
Detector Activation Temperature	X	X	X	X
Detector RTI	X	X	X	X
Rate of Heat Release	X	X	X	X
Spacial Dimensions of Compartment		X		X
Lining Materials of Compartment		X		X
Heat of Combustion		X		X
Fire Height		X		X
Vent Dimensions (Doors/Window)		X		X
Number of Vents				X
Fire Diameter				X
Curtain (Wall) Length				X
Height For Bottom of Curtains (Walls)				X

### (v) Input Data

The RTI for a heat sensitive element is a measure of its sensitivity and can be determined experimentally by both the plunge test, where the detector or sprinkler head is suddenly lowered into a flow of hot gas at a known constant temperature, and the rate-of-rise test, where the head is subjected to a flow of gas with uniform rates of rise of temperature.

## Chapter 11 - Fire Detection and Suppression

Table 11.2 gives some typical and worst-case values for the RTI of sprinkler heads.

**Table 11.2. Response time indices for sprinklers**

Sprinkler Type	Typical RTI	Worst Case RTI
	$m^{1/2} s^{1/2}$	$m^{1/2} s^{1/2}$
Fast response	30	100
Soldered link	150	N/A
8mm glass bulb	200	300

For heat detectors designed to comply with AS1603.1, there are 4 types possible, two with rate of rise function and fixed temperature, and two types with fixed temperature only.

**Table 11.3 Data on AS1603.1 Heat Detectors**

	Rate of rise function	Fixed Temperature
<b>Type</b>		
A	Yes	58- 88 C°
B	No	58 - 88 C°
C	Yes	88 - 132 C°
D	No	88 - 132 C°

The type A and C will give an alarm typically in the range 60 - 150 seconds if the rate of rise of temperature is 22 C°/min. Below about 10 - 12 C°/min, the rate of rise mechanism will not work.

Where fixed temperature detectors are employed or a conservative approach to use of rate of rise detectors is desirable, the data in Tables 11.4 may be used together with the RTI method for predicting activation times of heat detectors as fixed temperature devices.

**Table 11.4 Typical Data for Heat Detectors**

Type	Activation Temperature (C°)	RTI ( $m^{1/2} s^{1/2}$ )
A, B	58 - 88	10 -20
C, D	88 - 132	10 -20

One parameter that must be provided as input to hand calculations or computer models for determining the time to activation is the radial distance from the fire axis to the detector location of interest. This is illustrated in Figure 11.5

## Chapter 11 - Fire Detection and Suppression

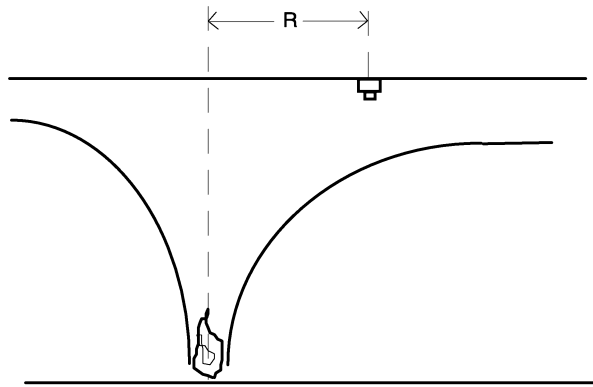

Figure 11.5 Radial Distance

For fire detectors, the radial distance R should be calculated using the formula

$$R = \sqrt{(l_1 / 2)^2 + (l_2 / 2)^2} \quad (11.3)$$

Where  $l_1$  and  $l_2$  are the spacing distance between detectors as illustrated in Figure 11.6,

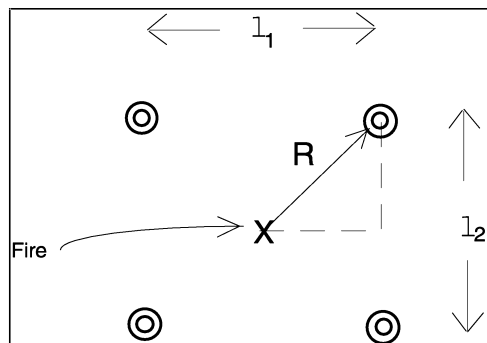

Figure 11.6 Calculation of Radial Distance

This distance R may also be appropriate for the sensing elements of sprinklers in respect of activation time. However, since more than one sprinkler head may be required for fire control or reduction in heat release rate, the distance R may be increased for suppression effectiveness calculations (see Section 11.6.3).

### 11.6.2.2 Smoke Detectors

The different principles of operation of the various types of smoke detectors make it difficult to provide one approach to prediction of smoke detector operating times. In addition, there is a dearth of well developed prediction methods and hence reliance has to be placed on some crude approximations - A conservative prediction should therefore be adopted.

Two sorts of approaches are adopted, namely :

## Chapter 11 - Fire Detection and Suppression

- equivalence to a heat detector
- zone model optical density measurements

### (i) Temperature Equivalence

Heskestad (Ref) undertook experiments and suggested that for some selected fire conditions, smoke detectors may detect fires at 13°C above ambient temperature.

This suggests that if  $\Delta T=13^{\circ}\text{C}$  and a low RTI ( $<10\text{m}^{1/2}\text{s}^{1/2}$ ) was used, this may give some crude estimate of the time to smoke detection when used in one of the heat detector computer models.

An extension of this approach has been proposed in a method by Evans (Evans : 1984) but this temperature equivalence approach is not preferred.

### (ii) Optical Density

If the optical density at alarm of smoke detector is known, then a better estimate of the time for detection can be made by reference to the optical density of smoke in the hot layer, or preferably in the ceiling jet. This latter parameter may be obtained from SS2.

Care should be taken to include a reasonable time delay between the arrival of smoke of the required optical density at the smoke detector location and its entry into the detector to cause activation.

However, for point-type smoke detectors conforming to AS1603.2, specified minimum levels of sensitivity to a range of test fires are required. These test fires are described in various parts of AS2362.

The minimum levels of sensitivity required by AS1603.2 are given in Table 11.5 for the 3 sensitivity classes of detectors.

**Table 11.5 - Test Limits for Smoke Detectors**

SENSITIVITY CLASS	DETECTOR TYPE		
	Photo-electric (optical)		Ionisation
	% / m	O.D. (db/m)	MIC <sub>x</sub>
Normal	12 - 20	0.55 - 0.97	0.35 - 0.55
High	3 - 12	0.13 - 0.55	0.1 - 0.35
Very High	0 - 3	0 - 0.13	0 - 0.1

These test limits for the 2 types of detectors and 3 sensitivity classes are based on response in a standard smouldering fire. Similar limits would apply for photo-electric (optical) detectors in a flaming fire.

The MIC<sub>x</sub> data for ionisation detectors is very difficult to relate to data produced by fire models. For response of ionisation detectors in smouldering fires, 0.55 MIC<sub>x</sub> corresponds to about 40 %/m obscuration or 2.2 db/m optical density and 0.35 MIC<sub>x</sub> corresponds to about 20 %/m or 0.97 db/m.

For flaming fires, ionisation detectors would normally operate before photo-electric detectors but for conservative design, the upper figures for each class of photo-electric (optical) detector should be used to predict time of operation.

## Chapter 11 - Fire Detection and Suppression

Designers should be careful not to use the markings on a smoke detector or its packaging as some form of sensitivity for design purposes. Many smoke detectors imported in to Australia are marked with a sensitivity rating such as 15 %/ft. This rating comes from a forced air test box at an overseas laboratory, usually UL (USA). The rating, which may be expressed as 4.5 %/m approximately, does not mean that the detector will operate in an enclosure fire at 4.5 %/m. Because of time delays associated with smoke entry and other factors, the detector may not operate until 10 or 15 %/m in the AS1603.2 standard laboratory test in Australia. Designers should use the data from Table 11.5 as indicated.

### 11.6.2.3 Beam Smoke Detectors

The response time for an optical beam detector may be calculated from the optical smoke density at the time of detector actuation as given by the equation:

$$D = \frac{10}{L} \log_{10} \frac{I}{I_0} \quad (11.4)$$

where

- $D$  is the optical smoke density (in db/m);
- $L$  is the optical measuring length (in m);
- $I_0$  is the radiated power received without smoke;
- $I$  is the radiated power received with smoke.

The response time for a given optical beam detector may be estimated to be the time at which the optical smoke density along its beam length exceeds the operating value.

The response of the optical beam detector can also be correlated with the local mass concentration of smoke using;

$$\ln \left( \frac{I}{I_0} \right) = k_m \bar{C}_s L \quad (11.5)$$

Where;

- $I$  is the intensity of light with smoke
- $I_0$  is the intensity of light without smoke
- $k_m$  is the specific extinction coefficient. Should be assessed for the specific wavelength of the light source and the property of smoke existing within the beam. However, a value of 7.6 m<sup>2</sup>/kg for flaming fires and 4.4 m<sup>2</sup>/kg for smouldering fires could be used.
- $L$  is the full length or a part of the optical beam where smoke exists
- $C_s$  is the average concentration of smoke. May be estimated from zone models.

## **Chapter 11 - Fire Detection and Suppression**

The detector activation time could be determined as the time at which the light extinction due to smoke concentration along the beam length exceeds the operating value.

### **11.6.2.4 Aspirating Smoke Detectors**

An aspirating detector system is one in which air is normally taken through the return ventilation system and sampled at a central point by an optical beam detector. For analysis purposes each sampling point can be modelled as an imaginary point detector.

The response level of aspirating detectors to optical smoke density can be individually set for each installation; they are often up to 10 times as sensitive as point-type detectors.

### **11.6.2.5 Flame Detectors**

Designers should take into account the appendix material of AS1670 and manufacturer's data when analysing and designing flame detection systems.

### **11.6.2.5 Probabilities of Fire Detection**

The following probabilities for detector and suppression system activation could be used as input into an appropriate risk assessment model (NBFSSC: 1991 : 66).

**Table 11.6 Probabilities of Successful Detector Activation**

<b>DETECTOR</b>	<b>Probability of Successful Activation</b>		
	Smouldering Fire	Non - Flashover Fire	Flashover Fire
Heat detector	0	0.9	0.95
Sprinkler	0.5	0.95	0.99
Smoke detector			
- Smoke Alarm	0.65	0.75	0.74
- AS1630.2	0.70	0.80	0.85
- Sampling	0.90	0.95	0.95

The failure rate for new sprinkler heads to operate correctly has been estimated at  $3.1 \times 10^{-2}$  and for old sprinklers at  $5.1 \times 10^{-2}$  (Nash and Young : 1991). With regard to a sprinkler system in an office building the probability of failure of the system has been estimated to be 0.0184 (Thomas, Bennetts, et al : 1992).

The rate of smoke detector malfunction has been estimated at  $1.2 \times 10^{-6}$ /hr (Steciak and Zalosh : 1992). The percentage of domestic smoke detectors in England and Wales that were found to be not working after 18 months from the time of installation was 7 % and after 36 months the percentage not working was found to be 11%.

### 11.6.3 Automatic Suppression

#### 11.6.3.1 General

The time to control or reduce the heat release rate of the fire is dependent on the time of activation and the time required for the suppression agent to become effective. This is illustrated in Figure 11.7

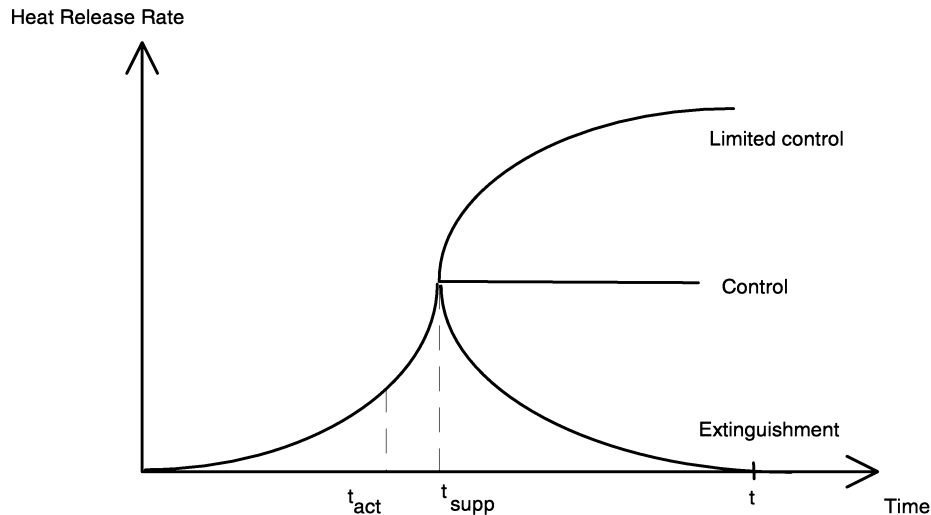

**Figure 11.7 Effect of suppression agent on the Heat Release Rate**

The time for activation ( $t_{act}$ ) is given in the earlier detection analysis (section 11.6.2). Additional time may be required for the heat release growth rate to be affected before suppression action becomes effective ( $t_{supp}$ ). This time between  $t_{act}$  and  $t_{supp}$  will depend on the type of suppression system and agent selected. The shape of the HRR curve following  $t_{supp}$  will similarly be determined by the agent and type of system.

It should be understood by designers that methods for prediction of  $t_{supp}$  and the modified HRR curve are crude and a conservative approach is required.

#### 11.6.3.2 Automatic Sprinklers

For conventional wet pipe sprinklers  $t_{supp}$  and  $t_{act}$  can be taken as coincident for most applications, particularly for situations where :

- enclosure height is low
- size of enclosure is small
- fire size is relatively low
- significant shielding of the fire is not expected
- the fire is likely to be extinguished with one or a few sprinkler heads

In these situations, some degree of reduction in heat release rate would be expected, and use of one of two equations may be appropriate :

##### 1. Madrzykowski and Vittori equation (Madrzykowski and Vittori : 1992)

$$\dot{Q}(t) = \dot{Q}_{act} \times e^{0.023\Delta t} \quad (11.6)$$

Where:



## Chapter 11 - Fire Detection and Suppression

$\dot{Q}(t)$  = heat release rate at time  $t$ ,  $t > t_{act}$

$\dot{Q}_{act}$  = Heat release rate at time of sprinkler activation

$\Delta t$  = Actual time from  $t = 0$  minus  $t_{act}$  where  $t_{act}$  = time of sprinkler activation

### 2. NIST equation (Fleming : 1993)

$$\dot{Q}(t-t_{act}) = \dot{Q}(t_{act}) \times \exp[-(t-t_{act})/3.0(w'')^{-1.85}] \quad (11.7)$$

Where;

$w''$  = spray density in mm/s

$\dot{Q}(t_{act})$  = Heat release rate at time of sprinkler activation  $t_{act}$

The NIST equation would generally be preferred than the previous equation as it takes into account variations in spray density.

Care must be taken in using equations 1 and 2 above as they are restricted to extra light hazard sprinklers and relatively small fire sizes.

In commercial and industrial applications, where roof heights may be higher, and where greater fire sizes and fire growth rates may occur, the difference between  $t_{act}$  and  $t_{supp}$  may be significant.

For example, conventional automatic sprinkler may only control fires by opening a number of sprinkler heads and pre-wetting surrounding fuel to prevent fire spread. For these situations,  $t_{supp}$  may be determined by choosing a larger  $R$  value for radial distance as input into the detector model as shown in Figure 11.8 below.

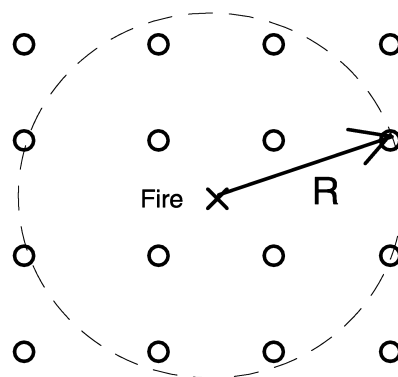

**Figure 11.8 Radial distance R for sprinkler control**

The Australian Statistics (Australian Fire Incident Statistics) and Marryatt (Marryatt : 1988) should be consulted for data on the number of sprinkler heads likely to be opened for fire control for any particular building occupancy type.

An even more conservative assumption in high challenge fires is to assume that less than perfect control is achieved. Some studies in UK indicate that sprinklers will increase the heat release rate doubling time at least by a factor of two.

## Chapter 11 - Fire Detection and Suppression

For early suppression fast response (ESFR) and large drop sprinklers, the design is based on fast activation and higher water densities to fully extinguish fires rather than just control them. Their design is based on the principle that for the fire growth rate/HRR of interest, the actual delivered density (ADD) of water from the sprinkler exceeds the required delivered density (RDD) for extinguishment. Analysis of ADD and RDD allows a design density to be selected that should lead to a rapid reduction in HRR. This concept is illustrated in figure 11.9 below:

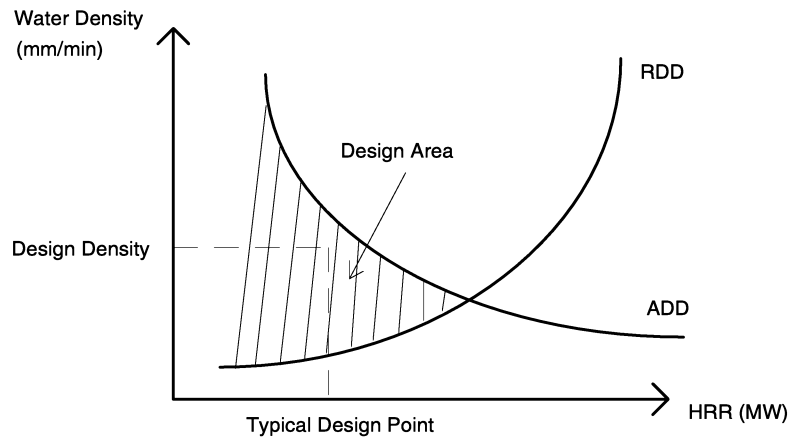

**Figure 11.9 ADD/RDD Design Approach**

### 11.6.3.3 Inert Gaseous Flooding Agents

Inert gaseous extinguishing systems should be designed in accordance with AS 4214 or NFPA 2001 using gaseous agents, hardware, and design software that have proven laboratory test and field performance in order to ensure that the system operates as designed. Leakage of the agent can also be a potential problem and effective commissioning of the system should be included as a design specification including pressurised leakage tests.

In order to reduce the oxygen concentration to typically 10 - 12 % to ensure extinguishment, relatively large volumes of gases can be required, in the order of 30 to 50% of the room volume in a total flooding situation.

Given activation the discharge of agent could take 1 to 2 minutes with possibly a further 1 minute to ensure complete mixing and total extinguishment. Hence the total time to extinguishment could be assumed to be approximately 3 minutes in a conservative design. The activation time may also include a time delay of approximately 30 seconds to ensure time for occupants to evacuate the area should also be taken into account.

The reduction in heat release rate for an inert gas flooding system is illustrated in Figure 11.10.

## Chapter 11 - Fire Detection and Suppression

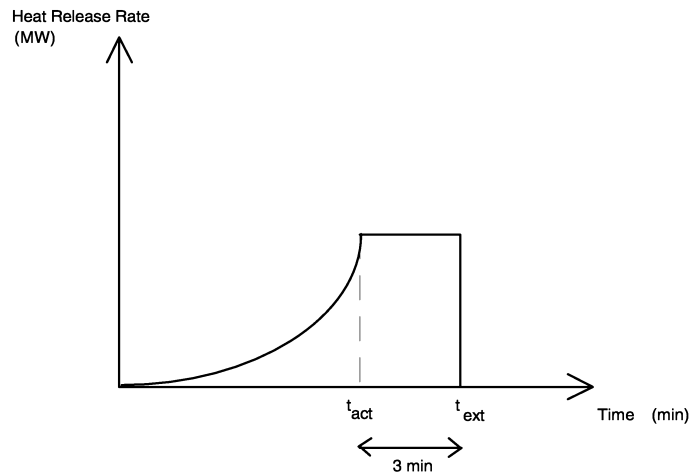

**Figure 11.10 Modification of HRR due to inert gas**

### 11.6.3.4 Chemical Gaseous Flooding Agents

Gaseous agents of the chemical type extinguish fires largely by chemical interaction with the combustion process. The concentrations of agents required are often in the range of 5 - 10 % volume and discharge is often completed in 10 - 20 seconds.

There is usually a time delay between detector alarm and discharge of 30 to 60 seconds for egress of the occupants that should be allowed for in any modelling work. The total time from detection to extinguishment would therefore be approximately 1 - 1.5 minutes for a conservative design.

The efficiency of suppression will depend to a certain degree on how effectively the compartment is sealed and incomplete sealing that allows agent to escape can result in only partial suppression. Installation to recognised standards such as AS 4214 and NFPA 2001 is therefore essential. Leakage testing of the compartments should also be performed as part of the commissioning process.

The reduction in heat release rates for a chemical gas flooding system is illustrated in Figure 11.11.

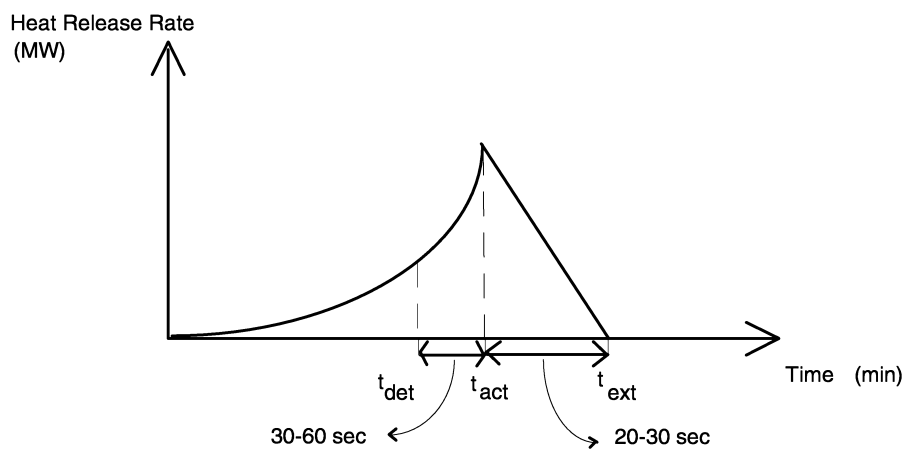

**Figure 11.11 Reduction in heat release rates for a chemical gas flooding system**

## **Chapter 11 - Fire Detection and Suppression**

### **11.6.3.5 Probabilities of Automatic Suppression**

Under detection/suppression activation, the probabilities of suppression activity starting are discussed. However, given that suppression starts, the next stage is to calculate the probability that the fire will be controlled and extinguished.

The WPI/Fitzgerald (Fitzgerald, Wilson : 1993) methodology for automatic sprinkler suppression that takes into account fire growth, water supply requirements, degree of maintenance is probably the only systematic approach available. It uses available statistical data and engineering judgement to estimate the probability of successful automatic suppression.

Data is available from BHP (Thomas and Bennetts, et al : 1992) based on fault tree analysis of sprinkler systems. Finally, data on successful control of fires is provided by H. Marrayatt (Marrayatt : 1988). Given his scientific definition of control, which is substantial fire area and building damage, Marrayatt concludes control is achieved in over 99% of fires in sprinklered buildings. His statistics provide some indication of the size of fire that would be controlled by one or more sprinklers in the Table 11.7.

**Table 11.7 Percentage of fires controlled by one or more sprinklers**

<b>No. Heads Required for Control</b>	<b>Percentage</b>
1	65%
2-5	27%
6-10	4.3%
>10	3.7%

For a Halon system in a computer facility the mean probabilities of failure of the system to protect against fire damage for various scenarios has been estimated to be 0.05 for an electrical cable fire, 0.13 for a waste paper fire and 0.08 for a fire outside the compartment of interest (Steciak and Zalosh : 1992). This compares with SSL data (Timms : 1988) that suggested that some 43% of gaseous halon systems failed to achieve and maintain extinguishing concentration in commissioning discharge tests.

### **11.6.4 Manual Suppression**

Occupants having responded to a fire cue or alarm signal (Refer to Chapter 12) may either decide to evacuate or attempt to fight a fire.

The probability of success should an occupant decide to fight the fire will depend on the size of the fire, the training of the occupant in the use manual suppression equipment, the number of occupants attempting to extinguish the fire, and the equipment used. An estimate of the probability of success can be derived from the work of Rexford Wilson as shown in Figure 11.12.

## Chapter 11 - Fire Detection and Suppression

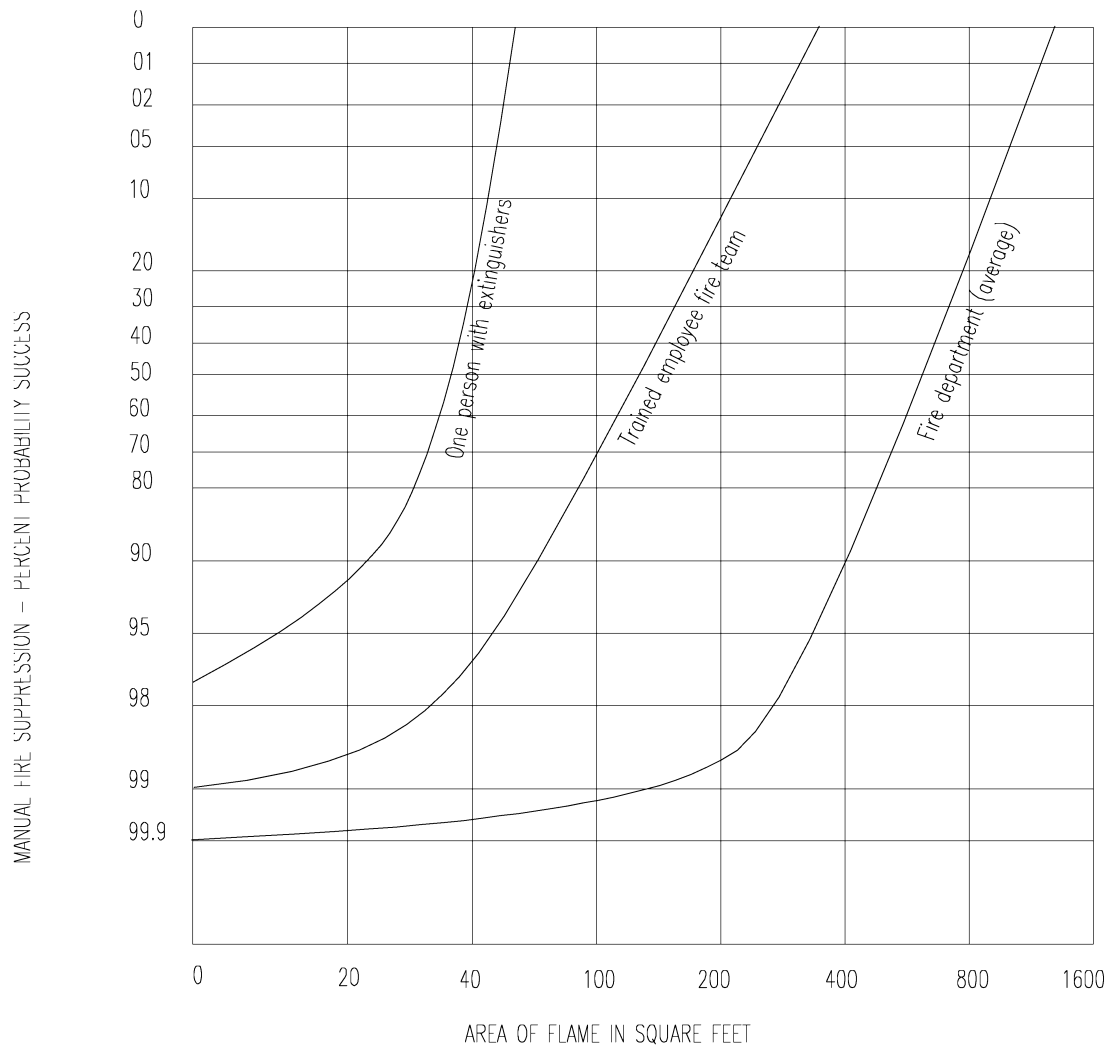

**Figure 11.12 Extinguishing Capability vs. Size of Flame Area  
Success Rate of Manual Extinguishment**

The percentage of occupants that will engage in fire fighting behaviour has been estimated in a study population from USA as approximately 23%. Of the percentage of occupants engaged in fire fighting behaviour approximately 24% attempted to fight the fire or extinguish the fire (Bryan : 1988 : 1-282).

The types of occupancies in which equipment provided within the occupancy was used to fight the fire are shown in Table 11.8 (Bryan : 1988 : 1-282).

## Chapter 11 - Fire Detection and Suppression

**Table 11.8 Occupancies in which Fire Fighting Equipment was Utilised by Participants in Fire Fighting Behaviour**

<b>Occupancy</b>	<b>Incidents</b>	<b>Percent</b>
Dwelling (1 family)	23	35.9
Apartment (<20 units)	18	28.1
Apartment(>20 units)	3	4.8
Restaurant	3	4.8
Manufacturing	2	4.8
Hotel and Motel	2	3.2
School	3	3.2
Billiard Centre	1	1.5
City Club	1	1.5
Hospital	1	1.5
Dwelling (2 family)	1	1.5
College Dormitory	1	1.5
Service Station	1	1.5
Office	1	1.5
Photographic Laboratory	1	1.5
Other	2	3.2
N=16	64	100

### **References**

Alpert R. " Calculation of response Time of Ceiling Mounted Fire detectors", Fire technology, Vol 8, 1972

Heskestad G. and Delichatsios M. A., "The initial Convective Flow in Fire", 17<sup>th</sup> International Symposium on Combustion, Combustion Institute, Pittsburgh, 1978

Delichatsios M. A., Combustion and flame, 43, 1, 1981

Evans D. D., Combustion Science and technology, 40, 79, 1984

Cooper L. Y., " A Buoyant Source in the Lower of two Homogeneous Stably Stratified Layers", 20<sup>th</sup> International Symposium on Combustion, Combustion Institute Pittsburgh, 1984

NFPA 92B, "Smoke Management Systems in Malls, Atria and Large Areas", 1991

## **Chapter 11 - Fire Detection and Suppression**

National Building Fire Safety Systems Code, Building Regulation Review task Force, May 1991, p66

Nash P. and Young, R. A., "Automatic Sprinkler Systems For Fire Protection", 2<sup>nd</sup> Edition, Paramount Publishing, 1991.

Thomas I, Bennetts I, Poon S. L., Sims J, "The Effect Of Fire In The Building At 140 Williams Street", The Broken Hill Proprietary Company Limited, 1992

Steciak J. and Zalosh R. G., "A Reliability Methodology Applied to Halon 1301 Extinguishing Systems in Computer Rooms", Fire and Hazard Risk Assessment, ASTM STP 1150, 1992

Madrzykowski D. and Vettori R., "A Sprinkler Fire Suppression Algorithm", Journal of Fire Protection Engineering, 4, 151 - 164, 1992

Flemming R., "International Sprinkler Scene", National Fire Sprinkler Association Inc. Vol. 2 No. 3, 1993

Marryatt H., "Fire, A Century of Automatic Sprinkler Protection In Australia and New Zealand", Australian Fire protection Association, 1988

Fitzgerald R. W. & Wilson R., "Building Fire Safety Evaluation: Workbook", Worcester Polytechnic Institute, Worcester, Massachusetts, 1983

Timms G., "Successful Operation and Failure of Water Sprinkler and Halon 1301 Fire Protection Systems", SSL report 88/Fs 26, 1988

Bryan J. L., "Behavioural Response to Fire and Smoke", SFPE Fire Protection Engineering Handbook, 1<sup>st</sup> Ed., Chapter 1 - 16, Page 1-269, 1988

## Chapter 12 - Occupant Avoidance

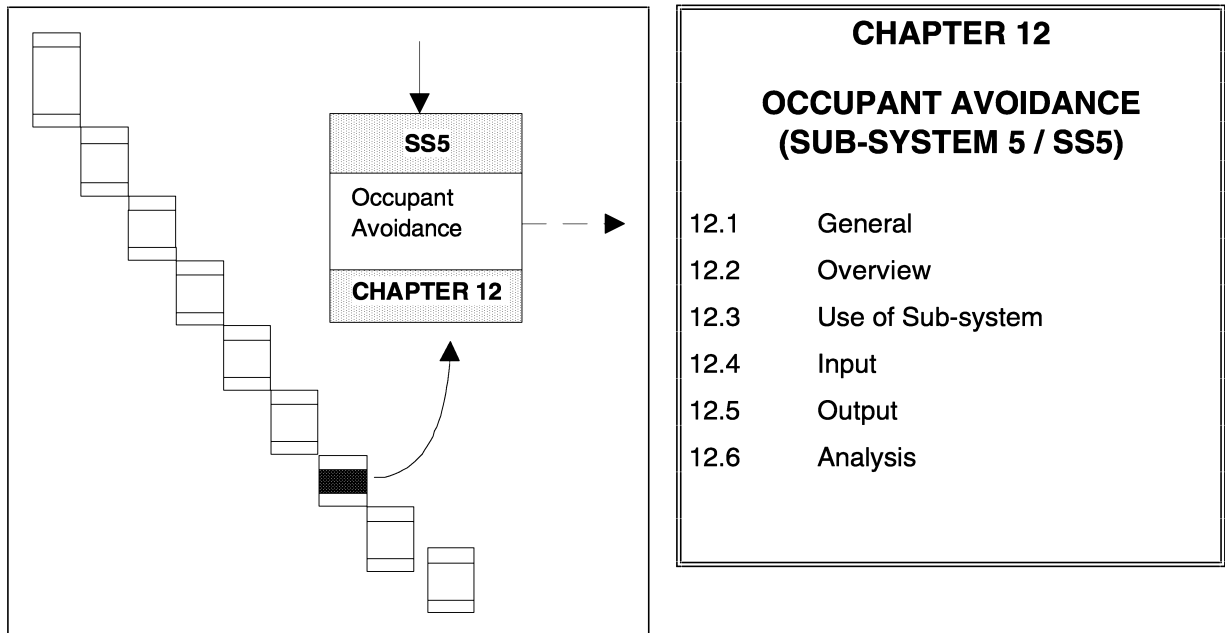

### 12.1 General

This chapter provides the methods and information to :

- (a) Define occupant capability ratings for response to cues, coping activities and movement to a place of safety in event of a fire ;
- (b) Determine and calculate the probability of cue and response and the time required by the occupants to become aware of, investigate and interpret information from intrinsic and automatic cues, as well as making a decision to either cope with the emergency or to evacuate to a safe place ; or to do both; and
- (c) Determine and calculate the time required by the occupants to reach a place of safety which then is used to calculate the number of occupants exposed to untenable conditions

This chapter also provides the methods and information for the designer to :

- (d) Design a fire alarm system that will be compatible with the needs and characteristics of the occupants in terms of the type and format of the information and the manner in which it is communicated ; and
- (e) Design an occupant avoidance sub-system to facilitate, support, enhance and manage the actions of occupants in their attempts to cope with and/or avoid the untenable conditions of a fire and/or the products of combustion taking into account their needs and characteristics .

### 12.2 Overview

Occupant Avoidance Sub-system provides the methods and information that can be used in the design process to ensure , in the case of fire , the safe evacuation of a building or that the occupants can avoid untenable conditions.



## **Chapter 12 - Occupant Avoidance**

The criteria used to measure the provision of a safe occupant avoidance sub-system is that the occupants are able to respond effectively to a fire alarm and ultimately avoid being subjected to untenable conditions by being able to move to a place of safety with or without the assistance of others or by fulfilling their role in a predetermined or otherwise occupant avoidance plan and procedures.

Methods and information are provided in Chapter 13 on provisions that should be made for the successful access of the Fire Brigade to fight the fire and effect rescue . These facilities when coupled with the design of the occupant avoidance sub-system or exit component must satisfy the rescue needs of the Fire Brigade . This is especially important when the exit component of the occupant avoidance sub-system may have failed .

This sub-system draws on the characterisation of the occupants as described in Chapter 7 which will determine their ability to respond to, cope with and successfully avoid the hazardous and untenable conditions of a fire . The most important of these are normally the number of occupants , their location and distribution as well as their physical and intellectual abilities together with their associated activity at the outbreak of a fire (the area of focus). The characterisation of the occupants provides input especially in terms of the use of the building and the associated activities and hazards . This chapter will provide input that can be used to determine whether or not the occupants are likely to be familiar or unfamiliar with the building , whether some occupants could be asleep or whether or not significant numbers of occupants might need assistance in an evacuation . This is one of the most important factors as it is the case with most public buildings (shops, offices, assembly, recreational and health care buildings) so that evacuation planning and the establishment of procedures form part of the occupant avoidance sub-system .

This sub-system also draws on other sub-systems such as those described in chapters 8 to 11. Outputs from these sub-systems dictate and are used to establish :

- (i) The time of occurrence of a detectable intrinsic cue i.e. fire related ;
- (ii) The time of occurrence of an occurrence of an automatic cue i.e. generated from an automatic detection device with the information being communicated to the occupants via a fire alarm ; and
- (iii) The time taken to reach untenable conditions which may be in the form of an environment of toxic combustion gases , excessive temperatures or radiant heat flux , and lack of visibility etc.(and hence the number of occupants exposed when the time required to evacuate or to avoid untenable conditions exceeds the time available).

Whilst profiles emanating from the sub-system are expressed quantitatively where possible it is essential that the actual sub-system itself is properly designed and specified especially in terms of ergonomic requirements from the informative structure of the alarm to the minimum widths and heights and the general geometry of exits . The latter forms an integral part of the internal planning and overall legibility of the building .

### **12.2.1 Philosophy / overall framework and submodel**

The contextual framework, dynamics and interactions of fire and occupant avoidance processes can be depicted as shown in the form of an outline Flowchart in Figure 12.1.

## Chapter 12 - Occupant Avoidance

From the moment a fire starts in some location within the building (enclosure of fire origin), there is for each space or enclosure and the associated occupants, a period of time available ( $T_a$ ) before the onset of untenable conditions for the occupants to either successfully avoid those conditions or to evacuate to a place of safety. As the fire grows and develops with time its sphere of influence will increase and threaten areas outside the enclosure of fire origin and hence an ever increasing number of occupants. The physical time available may actually reduce but this may not match the time perceived to be available by the occupants. Communication of the correct information to all the occupants is therefore of the utmost importance. Occupants will therefore require a certain amount of time to evacuate to a safe place or to successfully avoid untenable conditions ( $T_r$ ). The time available can be estimated from the sub-systems in the other chapters.

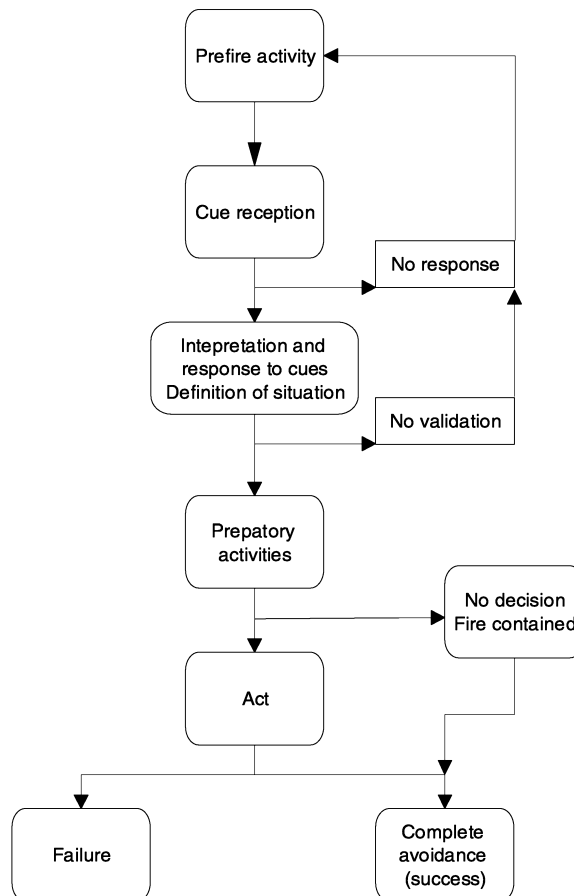

**Figure 12.1 - Dynamics of Fire and Occupant Avoidance**

The time required ( $T_r$ ) for the occupants to evacuate to a place of safety or to successfully avoid untenable conditions is simply the sum of its component parts for each enclosure within the building (allowance is made in capability ratios for cyclic occurrences). This can be represented as follows for an occupancy where the occupants may be asleep :

$$T_r = t_a + t_{aw} + t_p + t_{ie} + t_{eif} + t_s \quad (12.1)$$

The time prior to the initiation of evacuation oriented movement is represented by :

$$t_r = t_a + t_{aw} + t_p$$

and

$$t_c = t_{ie}$$

where :

$t_a$	=	time to arousal
$t_{aw}$	=	time to awareness of fire emergency
$t_p$	=	time to perceive fire threat
$t_{ie}$	=	time to initiate avoidance activities or evacuation actions
$t_{eif}$	=	time to evacuate fire threatened area or to avoid untenable conditions
$t_s$	=	time required to reach place of safety
$t_r$	=	response time
$t_c$	=	coping time

Traditionally  $t$  response ( $t_r$ ) and  $t$  coping ( $t_c$ ) are distilled from the human behaviour research . This should be avoided seeing human behaviour is present at all stages as is movement . It is therefore difficult to predict exact positions of occupants at set time intervals . Times for actual evacuation can still to a certain extent be derived from empirical studies .

It is essential that the actual exit system or emergency circulation system can accommodate contra flows in the form of fire-fighters for the function of rescue . The latter form part of sub-system 6 and the inputs are therefore provided from Chapter 13.

The overall framework and model for this chapter is shown overpage in the form of Figure 12.2.

### **12.2.2 Design**

The design process implicit for this sub-system comprises engineered design where an engineering analysis of all factors affecting occupant avoidance is carried out using a submodel along with the development of the design of the components of the actual sub-system , at each stage of the building design process e.g. schematic design, design development and contract documentation or as required depending on the level of design and analysis required i.e. in Chapter 3 of these Guidelines.

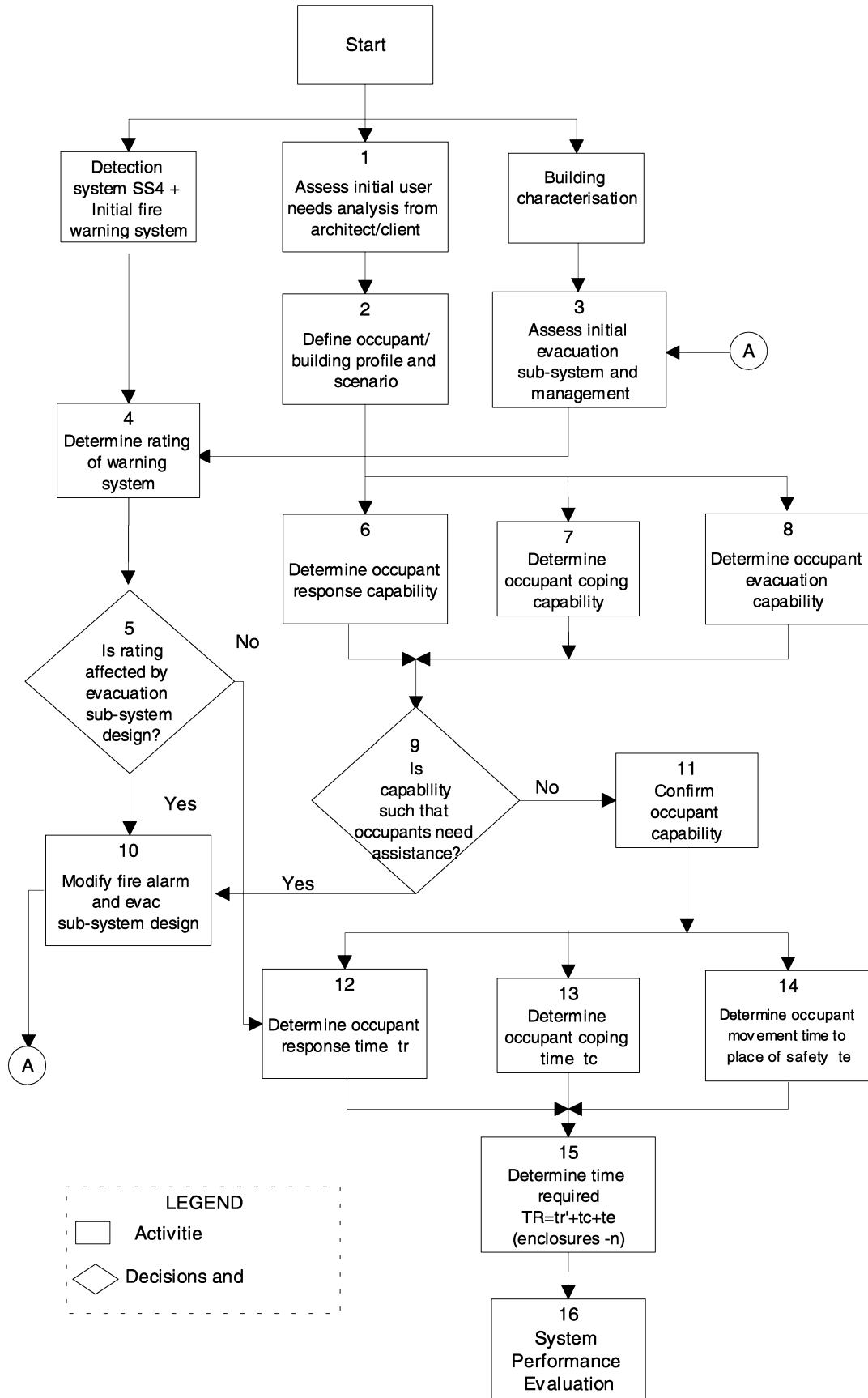

**Figure 12.2 Occupant avoidance sub-system flow chart**

### **12.2.2.1 Engineered Design**

The procedure or framework for the design and analysis of the occupant avoidance sub-system is illustrated in the Flow Chart in Figure 12.2 . It can be used for Level 1, Level 2 and Level 3 Design.

Depending on the purpose of the design select the appropriate level of design and use the framework as required . The procedure consists of the following :

- a. Using appropriate procedures from the sub-systems in chapters 8 to 11 which basically consist of taking time based information on the fire scenario, assessing its interaction with the initial building fire safety system and estimating the time available for escape i.e.. prior to the onset of untenable conditions for each space and enclosure as well as the escape or exit system .
- b. Concurrently with (a), an estimate of the response, coping and escape/egress times of the occupants is made taking into account the fire related environment and other environmental factors that may affect them together with the exit/escape routes provided .
- c. A comparison is then made between (a) and (b) on the basis that  $T_a$  (time available) is greater than  $T_r$  (time required). If (a) is less than (b) then the design must be revisited to either decrease (b) or increase (a) . This concept is explained in detail in Section 6.8.4.3.

### **12.2.2.2 The Flow chart**

The text describing the activities, considerations and decisions necessary at each stage of the analysis and the design process may be found in section 12.6 for each relevant part of the submodel and sub-system illustrated by the flow chart in Figure 12.1. Appendix 12A contains the detailed information required for design.

## **12.3 Use of Sub-system**

### **12.3.1 General**

The overall submodel for occupant avoidance is shown in Figure 12.1. The purpose of this diagram is to indicate that movement is not merely confined to evacuation activities but may be found in the initial activities such as investigation which is prior to perceiving that there is a fire and that it poses a threat . It is also intended to indicate that occupant avoidance is not linear in that the sequence of activities do not necessarily lead towards a safe place . It is therefore essential to select the most appropriate occupant and fire scenarios for each analysis which will also be affected by the level of design undertaken in accordance with the procedures set down in Chapter 3 of these guidelines.

## **12.4 Input**

### **12.4.1 Occupant Characteristics**

Occupant characteristics include information on:

- Occupant profile
- Occupant response capability factors
- Occupant coping capability factors

- Occupant evacuation/avoidance capability factors

Details of occupant characteristics are given in Chapter 7.

### 12.4.2 Building Characteristics

Building characteristics include information on:

- Building footprint geometry and layout
- Fire safety and evacuation sub-systems
- Occupant locations

Details of building characteristics are given in Chapter 7.

## 12.5 Output

### 12.5.1 Occupant Avoidance Time

The time required ( $T_r$ ) for the occupants to evacuate to a place of safety or to successfully avoid untenable conditions and the probability of successful avoidance will form the basis of the output from this sub-system.

## 12.6 Analysis

This Section (12.6) of Chapter 12 is intended to provide the designer with information or sources of information to enable the design of the Occupant Avoidance Sub-system to take place.

### 12.6.1 Preliminary Procedures

This section refers to all Events in the Flow Chart, Fig 12.2.

**Event No. 1** is entitled 'Assess Initial User Needs'. This assessment should be carried as part of the FEDB. Information can also be gathered from Post Occupancy Evaluation checks (POE) The purpose of this step is to assess the type of information required with reference to event 2 (Section 7.6) and then to compare it with what is available. This procedure identifies the shortfall and the extent as well as the scope of the study required for under Event 2. Quite often the designer maybe dealing with an expert client (eg. retailer, hospital administrators etc.) or when this is not the situation the designer can identify the need for additional expert advice (eg. multi-residential → urban sociologist).

**Event No. 2** is entitled 'Define Occupant / Building Profile'. Using the information gathered from Event One carry out investigations to establish factors listed in Section 7.6. The procedure used could comprise:

- (a) Delphi Group (for expert client) as well as structured interview.
- (b) Structured interview of Expert or Expert Client and reconciliation with historic data.
- (c) Analysis of historic data.
- (d) Briefing by Expert Architect.

This procedure should be written up as a report and the results thereof incorporated in the Design Brief and FEDB. It can be used to identify the main parameters for the design of the sub-system and management thereof.

## Chapter 12 - Occupant Avoidance

**Event No. 3:** is entitled 'Assess initial Evacuation Sub-system and Management' The suggested procedure for this event is either,

- (a) Design Initial Sub-system from appropriate Code eg. BCA, NZBC Approved Documents or NFPA 101
- (b) Design Initial Sub-system based on a past project with a similar occupant profile
- (c) Design Initial sub-system based on results of research which have been tested.
- (d) Design Initial sub-system based on first principles analysis of occupant profile.

**Event No. 4:** is entitled 'Determine Rating of Warning System'. Warning system in this sense is rated according to the overall clarity (intent and format) of the information conveyed in the alarm. This includes intrinsic cues (Cue B) to the most informative fire warning system. Examples of ratings may be found in Tables 12.2 and 12.3.

**Event No. 5:** If the warning system proposed by the design of sub-system (SS5) five is unsuitable for the requirements of events 6-8 then the alarm must be changed and retrialed via Activity 3 as indicated on the Flow Chart. Similarly if decision node 9 indicates that the Fire Alarm proposed is incompatible with the (eg. cells for the hearing impaired or an environment with a high ambient noise level) needs of the occupants then a new fire alarm should be selected and retrialed through Event No. 10.

**Event No.s 6,7,8 and 9:** Once the occupant capability factors have been determined (Activity No.s 6-8) they should be tested by decision node 9 which is 'Is Capability such that Occupants need assistance?' This test involves comparing the findings resulting from the development of an occupant profile as described in Section 7.5 with the initial occupant avoidance sub-system or requirements outside the building fire safety system eg. security or building occupancy factors related to overall user needs.

**Event No.s 10 and 11:** If decision node 9 indicates that the Fire Alarm proposed is incompatible with the (eg. cells for the hearing impaired or an environment with a high ambient noise level) needs of the occupants (i.e the answer is 'yes') then a new fire alarm should be selected and retrialed through Event No. 10.

If decision node 9 indicates that the Fire Alarm proposed is compatible with the needs of the occupant (i.e the answer is 'no') then the occupant capability ratings can be confirmed (Activity 11). A negative answer will require a redesign of the evacuation sub-system where assistance will be required and the extent and type would be specified (Activity numbers 10 and 3). The occupant profile should also be changed.

**Event No.s 12,13 and 14:** The next major procedure is to define occupant capability factors,  $t_r$  (Response time) and the probability of occurrence  $P_{qr}$ ,  $t_c$  (coping time) and finally  $t_e$  (evacuation time) (Activities 12 - 14). These are fully explained in Section 12.6.

Once the times have been calculated the overall evacuation time is established for each enclosure commencing with the enclosure of fire origin. The results should be tabulated using formats similar to those available in 'Evacnet' and/or 'Wayout' depending on the type of evacuation envisaged. The number of persons in each enclosure at each interval of evacuation should also be noted (standard output from Evacnet).

**Event No.15:** The purpose of this is to be able to establish the number of persons exposed at time  $T_A$  in a given enclosure (Section 6.8.4.3).  $T_r$  must be calculated for that enclosure. This time should also form part of the output or be calculated using a spreadsheet where:

## Chapter 12 - Occupant Avoidance

$$Tr = tr' + tc + te \text{ (enclosures -n.)}$$

$$(tr' \text{ here} = tr(qA) \text{ or } tr(qB))$$

**Event No. 16:** Tr value calculated is used in System Performance evaluation as explained in Chapter 6.

### 12.6.2 Occupant Response

#### 12.6.2.1 Determination of Occupant Response Time ( $t_r$ ) and Probability ( $P_r$ )

This section sets out the procedures and requirements for the determination of  $t_r$ , as well as the associated probability  $P_r$ . The requirements are basically :

- providing a means of communicating a message of warning about the presence of a fire to the occupants with a view to successfully alerting them
- the activities carried out by the occupants in responding to the cue(s) to the point where they perceive that the fire poses a real threat .

There are two types of cues that should be considered :

- (a) Cue A ; cues that communicate information via automatic audible, visual, or tactile alarms to the occupants
- (b) Cue B ; cues that are intrinsic and communicated to the occupants either via fire and smoke spread, other occupants and ambiguous signs - this also includes investigative activities to confirm or otherwise the presence of a fire (detected via visual, olfactory or auditory senses).

The design of hardware associated with cue A must state the type of alarm system to be used together with the type, structure and format of the information to be communicated and the likely response of the occupants to that signal or information .

Where hardware is not provided to generate Cue A , reliance should be placed on the following to generate Cue B ;

- direct contact of occupants with a fire or its combustion products
- occupants warning others
- response to ambiguous cues which have been validated after investigation

The purpose of this portion of the Occupant Avoidance Sub Model is to determine the time and probability of response ( $t_r$  and  $P_r$ ).

- (a) The probability of response is  $P(qA)$
- (b) The total time for Cue A and response is :

$$t_r(qA) = tqA + t_r(\text{base}) * Rc \quad (12.2)$$

where  $t_r(qA)$  is the response time to Cue A  
 $tqA$  is the time of occurrence of Cue A  
 $Rc$  is the Response Capability Factor  
 $t_r(\text{base})$  is the baseline response time ( $qA$ )



## Chapter 12 - Occupant Avoidance

(c) The probability of cue B and response is:

$$P_r(qB) = P_{qB} \times P_r(occ)qB \quad (12.3)$$

where  $P_r(qB)$  is the probability of response to Cue B  
 $P_{qB}$  is the probability of Cue B  
 $P_r(occ)qB$  is the probability of successful occupant response to Cue B

(d) The total time for Cue B and response is:

$$t_r(qB) = tqB + t_r(base) * R_c \quad (12.4)$$

where  $t_r(qB)$  is the overall response time to Cue B  
 $tqB$  is the time of occurrence of Cue B  
 $t_r$  is the baseline response time for (qB)

See tables 12.1 to 12.4 for probabilities of response to CueA and CueB

See Sections 12.6.2.2 and 12.6.2.3 for information on typical procedure based on this section See Flowchart , Figure 12.2, Activity numbers 12 and 15.

**Table 12.1 Alarm Probabilities - CUE A**

Type of Alarm	Alarm Probability P(qA)
A1 = Alarm Bell	0.95*
A2 = Sounder / Horn with rise and fall signature	0.90*
A3 = A2 plus recorded message and/or informative warning system Include. AS2220 system	0.8*
A4 = A2 plus directive Public Address System + CCTV	0.7*

**Table 12.2 Probability of Response - CUE A**

Enclosure Number	Alarm Type	Probability of Response (Average Scenario) P r (qA)
1	A1	0.6
	A2	0.7
	A3	0.9
	A4	0.95
2	as per Enclosure 1	reduce values by 20%
j	as per Enclosure 1	reduce values by 35%

## Chapter 12 - Occupant Avoidance

**Table 12.3 Probability of Cue B**

Cue Information Type and position of Occupant by distance or enclosure	Probability of Cue B P(qB)		
	Smouldering	Non Flashover	Flashover
B1	0.85	0.9	1.0
B2	0.9	0.9	1.0
B3	0.02	0.02	0.05
B4	0.02	0.02	0.10

**Table 12.4 Probability of Response to Cue B**

Cue Information Type and Position of the Occupant by distance or Enclosure	Response Capability (Rc eff )	Probability of Response P r.(qB)
B1	0 - 5	0.0- 0.6
B2	0 - 5	0.0- 0.7
B3	0 - 5	0.0- 0.3
B4	0 - 5	0.0 - 0.5

### **12.6.2.2 Occupant Response Capability / Calculation of Response Factor Rc (See also Chapter 7)**

This section is concerned with an explanation of the procedure comprising Activity number 6 in the Flow Chart.

In order to determine the likely contributions of each occupant response factor listed and defined in Chapter 7 it is essential that the Occupant Profile is firstly determined as described in Section 7.8. The data gathered will assist with the scoring of each of the factors. The latter are defined in detail in Chapter 7 and are listed below:

- (a) Alertness
- (b) Mobility
- (c) Social Affiliation
- (d) Role
- (e) Position
- (f) Commitment

## Chapter 12 - Occupant Avoidance

(g) Focal Point

(h) Familiarity

These factors can be used to characterise the occupants of occupant groups on a scale of one to five as defined in the Coding Scheme in Table 12.5....eg. for the factor alertness:

(i) asleep =\* (1)

to

(ii) awake >\*\*\*\*\* (5)

The response factors are listed in Table 7.5 on the 'X' axis and the Occupancies on the 'Y' axis. Each one of the cells have been scored. these are merely suggestions and should be completed as a result of the Occupant Profile Assessment.

**Table 12.5                      Occupant Response Capability Rating Scales**

<b>CAPABILITY WEIGHTING FACTORS (Rc eff)</b>							
<b>A</b>	<b>B</b>	<b>C</b>	<b>D</b>	<b>E</b>	<b>F</b>	<b>G</b>	<b>H</b>
Alertness	Mobility	Social Affiliation	Role	Position	Commitment	Focal Point	Familiarity
<i>asleep</i>	<i>impaired</i>	<i>group</i>	<i>public</i>	<i>lying</i>	<i>high/ involved</i>	<i>none</i>	<i>unfamiliar</i>
*	*	*	*	*	*	*	*
**	**	**	**	**	**	**	**
***	***	***	***	***	***	***	***
****	****	****	****	****	****	****	****
*****	*****	*****	*****	*****	*****	*****	*****
<i>awake</i>	<i>Highly</i>	<i>alone</i>	<i>staff</i>	<i>moving</i>	<i>low</i>	<i>focussed</i>	<i>familiar</i>

The most important factor to consider is the actual fire warning. The occupant response procedure may itself influence the decision as to which fire alarm should be used.

Finally to calculate response factor (R<sub>c</sub>) using weighted efficiency factor averages (Weff) the following formula should be used:

$$\text{Weff for } R_c = \frac{(3 \text{ main factors} \times 2 + 5 \text{ secondary factors} \times 0.4)}{\text{Total no. of factors}} \quad (12.5)$$

$$R_c = (6 - \text{Weff}) \quad (12.6)$$

See Flowchart, Figure 12.2, Activity No's 1,2,6,9 and 11.

## Chapter 12 - Occupant Avoidance

### 12.6.2.3 Occupant Response Time - $t_r$ (Flow Chart Activity Number 12)

This procedure is explained to a certain extent in Chapter 7. It should be noted that response times may be based on the following:

- (a) those identified in Tables 12.6 and 12.7
- (b) those identified in the literature eg. Sime J.D.
- (c) those identified via role play (forming part of training procedures or structured field study)

**Table 12.6 Cue A - Matrix Of Baseline Time Estimates Of Response Time**

Warning System	Response Time ( $t_{resp}$ ) (minutes)		
	Best Scenario effective training	Average Scenario	Worst Scenario no training/experience
A1= Alarm Bell	< 4	7	> 10
A2 = Sounder/Horn with rise/fall signature	< 3	5	> 7
A3 = A2 plus recorded message and/or informative warning system	< 2	3.5	> 5
AS2220 system A4 = A2 plus directive Public Address System plus CCTV	< 1	2	> 3

**Table 12.7 Cue B - Matrix of Baseline Estimates of Response Time**

Warning System	Response Time ( $T_r$ ) (minutes)		
	Best Scenario	Average Scenario	Worst Scenario
B1 = Intrinsic cue other than visual and to warn next person in enclosure of fire origin or < 10m from fire.	< 4	6	> 8
B2 = Visual Cue and to warn next person in enclosure of fire origin or < 10m from fire	< 2	3	> 4
B3 = Intrinsic cue other than visual and to warn next person outside enclosure of fire origin or > 10m from fire	< 8	12	> 16
B4 = Visual cue > 10m from fire or warned by another person include additional investigation	< 6	8	> 10

## Chapter 12 - Occupant Avoidance

Note : All of the above include all activities up to the commencement of coping cycle .

If procedures identified under items (b) and (c). are used than it may be necessary to adjust  $R_c$ .

$t_r$  (baseline) and hence  $t_r$  are calculated as follows.

(i) Enter the best possible scenario baseline design value of  $t_r$  (baseline).

(ii)  $t_r = t_r$  (baseline) \*  $R_c$  from Section 12.6.3. (12.7)

(iii) Section 12.6.2.1 for calculation of  $t_r(qA)$  or  $t_r(qB) = t_r'$

### **12.6.3 Occupant Coping**

#### **12.6.3.1 Determination of Occupant Coping Time**

$$t_c = t_{ie} = (t_{ie} \text{ mobile}) * C_c \quad (12.8)$$

Occupants' coping time depends on the type of activities undertaken as some of these may involve a great deal of movement. Examples as follows:

- a. Alerting and warning others
- b. Assisting others
- c. Gathering valuables
- d. Dressing
- e. Securing work area
- f. Returning to work area
- g. Working out action plan
- h. Fighting the fire, etc.

The extent of coping activities depend very much on the building evacuation strategy, the occupant capability, degree of training and experience and emergency communication and warning system. This phase of evacuation or occupant avoidance can be optimised and may even be ignored in some instances when well rehearsed procedures are in place.

See 12.6.3.3 for further detail.

See Flowchart, figure 12.2, Activity Numbers 13 and 15.

#### **12.6.3.2 Occupant Coping Capability / Calculation of Coping Factor $C_c$**

The likely activities were described in Section 12.6.3.1 the extent of the activities will depend on the detail in the building emergency control plan and evacuation procedures that are actually put in place as well as the factors determined from the Occupant Profile Study.

The factors comprise:

- (a) Mobility
- (b) Communication
- (c) Social Affiliation
- (d) Role

## Chapter 12 - Occupant Avoidance

- (e) Commitment
- (f) Decisiveness
- (g) Position
- (h) Familiarity

**Table 12.8 Occupant Coping Capability Rating Scales**

<b>CAPABILITY WEIGHTING FACTORS (Cc eff)</b>							
<b>A</b>	<b>B</b>	<b>C</b>	<b>D</b>	<b>E</b>	<b>F</b>	<b>G</b>	<b>H</b>
Mobility	Communication	Social Affiliation	Role	Commitment	Decisiveness	Position	Familiarity
<i>impaired</i>	<i>ineffective</i>	<i>group</i>	<i>public</i>	<i>high</i>	<i>nil</i>	<i>lying</i>	<i>unfamiliar</i>
*	*	*	*	*	*	*	*
**	**	**	**	**	**	**	**
***	***	***	***	***	***	***	***
****	****	****	****	****	****	****	****
*****	*****	*****	*****	*****	*****	*****	*****
<i>Highly</i>	<i>effective</i>	<i>alone</i>	<i>staff</i>	<i>nil</i>	<i>focussed</i>	<i>moving</i>	<i>familiar</i>

Each of these factors are fully defined in Chapter 7. They are also listed along the X axis of Table 12.8. Using the same coding procedure as described in Section 12.6.2.2 rate each cell against the appropriate occupancy, see also Table 7.9. The output from the Occupant Profile Study should also be used.

Thus to calculate coping factor (C<sub>c</sub>) using weighted coping capability factor averages (Weef) the following formula should be used::

$$W \text{ eff for } C_c = \frac{(3 \text{ main factors } \times 2 + 5 \text{ secondary factors } \times 0.4)}{\text{Total no of factors}} \quad (12.9)$$

$$C_c = (6 - W \text{ eff}) \quad (12.10)$$

See Flowchart, Figure 12.2, Activity No's 1,2,7,9 and 11)

### 12.6.3.3 Occupant Coping Time - t<sub>c</sub> (Flow Chart Activity No. 13)

Occupant coping time as previously explained is very much a function of past experience, and the design if any of appropriate evacuation procedures. Information or coping time in residential occupancies where there may be no evacuation procedures in place has been assembled by researchers as Pearson and Joost, Sime J.D., Proulx, G.

t<sub>c</sub> may be calculated as follows:

- (i) Enter the best possible scenario baseline design value of t<sub>c</sub> (baseline)

## Chapter 12 - Occupant Avoidance

$$(ii) \quad t_c = t_c (\text{baseline}) * C_c \text{ from Section 12.6.3.2} \quad (12.11)$$

**Table 12.9 Coping Cycle Matrix of Baseline Estimates of Coping Time**

Evacuation Procedures/ Communication System	Coping Time (T c)		
	Best Scenario	Average Scenario	Worst Scenario
C1 = No set procedures so large number of activities possible on group by group basis .Also complicated procedures.	< 4	6	> 8
C2 = Set procedures or informative warning system plus updating	< 2	3.5	> 5
C3 = C2 plus directive procedures via CCTV and P.A.	< 1	2	> 3

### 12.6.4 Occupant Evacuation/Avoidance

#### 12.6.4.1 Determination of Occupant Evacuation/Avoidance Time and Number of Persons Exposed to Untenable Conditions

$$t_e = (t_{eif} (\text{mobile}) + t_s) * E_c \quad (12.12)$$

the procedure should therefore be:

- (a) Establish Occupant Profile (Section 7.8)
- (b) Establish Evacuation Capability Factor (Sections 7.5 and 12.6.4.2)
- (c) Establish total population on each zone (use table D1.13 BCA, Table A2, NZBC Approved Documents and/or NFPA 101. or detailed determination under Section 12.6.9 forming part of the Fire Engineering Design Brief) (see Appendix 12A).
- (d) Establish location criteria for exits based on:
  - Architect designed proposal for exit system including access evaluated for capacity and safety
  - Prescribed location criteria as per Part D1 of the BCA or NFPA 101
  - Evaluation of  $E_c$  from Sections 7.5 and Appendix 12B and establishment of suitable access radii being 30-40 m for closed planning and 50-60 m for open planning with similar visual access.
- (e) Establish exit capacity using the Effective Width Model as a means of assessing target time for  $t_{eif}$  and overall  $t_e$ . (Do not use 'start up' component of this model in this instance).

## Chapter 12 - Occupant Avoidance

- (f) Calculate total  $T_r$  for each enclosure ( $T_r$  for  $n$  enclosures) and test initial sub-system design from sketch plans. Also evenly distribute exits around each zone under consideration
- (g) Repeat but for detailed sub-system design using an appropriate Evacuation Model.

See Section 12.6.4.3 for further detail.

See Flow Chart, Figure 12.2, Activity Numbers 14 and 15.

### **12.6.4.2 Occupant Evacuation Capability / Calculation of Evacuation Factor $E_c$**

The Occupant Evacuation/Avoidance capability is associated with activities related to either moving to a place of safety or avoiding the harmful products of combustion at the point where conditions become untenable. There are two components of the evacuation process which when translated into time comprise:

- $t_{eif}$ : egress time required from fire threatened area  
and
- $t_s$ : egress time required through the exit system

The occupant capability to complete the above activities must be assessed. The factors involved comprise:

- (a) Familiarity
- (b) Visual Access and Signage
- (c) Complexity
- (d) Population - occupant loading, structure and crowdedness
- (e) Mobility
- (f) route geometry/Safety
- (g) Social Affiliation
- (h) Role

These factors are defined in Chapter 7. Many of these factors assume a base occupant avoidance sub-system and should therefore be based on an assessment of the Architectural Sketch Plans in accordance with the components of the sub-system.

The evacuation/avoidance capability factors are listed along the X axis of Table 12.7. Using the same coding procedure described in Section 12.6.3 score each cell against the appropriate occupancy as per Table 7.5.

The output from the Occupant Profile Study should also be used. Thus to calculate evacuation factor ( $E_c$ ) using weighted evacuation efficiency factor averages ( $W_{eff}$ ) the following formula should be used::

$$W_{eff} \text{ for } E_c = \frac{(3 \text{ main factors} \times 2 + 5 \text{ secondary factors} \times 0.4)}{\text{Total number of factors}} \quad (12.13)$$

$$E_c = (6 - W_{eff}) \quad (12.14)$$

This will now be used to establish  $t_{eif}$  and  $t_s$  in Section 12.6.4.1.



## Chapter 12 - Occupant Avoidance

**Table 12.10 Occupant Evacuation / Avoidance Capability Rating Scales**

<b>EVACUATION/AVOIDANCE WEIGHTING FACTORS (E<sub>c</sub> eff).</b>							
<b>A</b>	<b>B</b>	<b>C</b>	<b>D</b>	<b>E</b>	<b>F</b>	<b>G</b>	<b>H</b>
Familiarity	Signage	Complexity	Population	Mobility	Safety	Social Affiliation	Role
<i>Unfamiliar</i>	<i>None</i>	<i>Complex</i>	<i>High</i>	<i>Impaired</i>	<i>Unsafe</i>	<i>Group</i>	<i>Public</i>
*	*	*	*	*	*	*	*
**	**	**	**	**	**	**	**
***	***	***	***	***	***	***	***
****	****	****	****	****	****	****	****
*****	*****	*****	*****	*****	*****	*****	*****
<i>familiar</i>	<i>Well</i>	<i>Well defined</i>	<i>Low</i>	<i>Highly</i>	<i>Safe</i>	<i>Alone</i>	<i>Staff</i>

### 12.6.4.3 Occupant Evacuation/Avoidance Time - E<sub>c</sub> (Flow Chart Activity No's 14 and 15)

Occupant evacuation/avoidance time (t<sub>e</sub>) comprises two components as explained in section 12.2.1 comprising t<sub>ei</sub>f and t<sub>s</sub>.

t<sub>ei</sub>f is the component that normally involves travel within the compartment of fire origin (eg. high rise office floor) and t<sub>s</sub> is the travel time through the exit system. It includes time taken to enter the exit. The time required can be established relatively easily using any of the approved evacuation models (all for only uncontrolled evacuations):

- (a) Evacnet+
- (b) Wayout
- (c) Evacsim
- (d) Evacgraph
- (e) Effective Width

or manually via the method set down in SFPE Fire Protection Engineering Handbook in the Chapter entitled Emergency Movement. The time is calculated for a person with no mobility problems in a perfect occupant avoidance sub-system. The adjusted t<sub>ei</sub>f is therefore:

$$t_{ei}f \text{ (mobile)} * E_c \tag{12.15}$$

t<sub>s</sub> and t<sub>ei</sub>f on other floors or in other compartments should be calculated using the same approach except that the adjustment of t<sub>s</sub> using E<sub>c</sub> should be examined fully thus t<sub>e</sub> = t<sub>ei</sub>f(adjusted) + t<sub>s</sub>.

### 12.6.5 Use of TR in System Performance Evaluation (Flow Chart Activity No. 16)

Computing TR is not merely the sum of  $t_r$ ,  $t_c$  and  $t_e$  or  $T_r$  for  $n$  enclosures. It involves the full use of one of the evacuation models. The models that are most suitable for this approach are those where:

- (a)  $t_r$  and  $t_c$  can be summed for each enclosure and included with the traditional input in the form of elapsed time or delays, or
- (b)  $t_r$  and  $t_c$  can be spread throughout or applied as a further weighting to traditional movement velocities or flows where this is possible.

Models so used must also be capable of establishing the number and location of occupants during the simulation. The purpose of this is to permit a post process analysis of fire growth and spread results, which can be used to establish the time and location of untenable conditions and which are then compared with the time required to evacuate the same area.

#### **References**

##### REFERENCES FOR $R_c$ - RESPONSE CAPABILITY

Keating, J.P., Loftus E.F., (1977) Vocal Alarms for High Rise Buildings - A Case Study in Mass Emergencies, Elseiner

Jones B.K., Hewitt A.J., (1986) Leadership and Group Formation in High Rise Building Evacuations, in Fire Safety Science, Proceedings of the First International Symposium, Hemisphere Publishing Corp. Washington, 513-522

Canter, D., Powell J., Bookerk (1988) Psychological Aspects of Informative Fire Warning Systems, BRE Report BR 127, Borehamwood

Geyer T., Bellamy L., etal. (1988) An evaluation of the effectiveness of the components of informative warning systems, in Safety in the Built Environment, (Sime J. ed) Span

MacLennan H.A. (1988) Simes J.D. Pauls J.L, Survey and Analysis of Response to a Variety of Audible Fire Alarms (including other occupants), UTS, Sydney

Ramachandram G. (1991), Informative Fire Warning Systems, Fire Technology, 47, 1, pp66-81

Sime J.D., Proulx G., (1991) To Prevent Panic in an Underground Emergency, Why not tell People the Truth.

Proulx, G. (1993) A Stress Model for People Facing Fire, Journal of Environmental Psychology, 13, pp 137-147

##### REFERENCES FOR $C_c$ - COPING

Pearson, R.G., Joost M.G. (1983) NBS-GCR-83-429, National Bureau of Standards (now National Institute of Standards and Technology), Gaithesburg

Bryan, J.L. (1983) An examination and Analysis of the Dynamics of the Human Behaviour in the MGM Grand Hotel Fire, NFPA, Quincy

## Chapter 12 - Occupant Avoidance

Bryan K., (1983) An Examination and Analysis of the Dynamics of Westchase Hilton Hotel Fire,

Canter D., (1985) Studies of Human Behaviour in Fire: Empirical Results and their Implications for Education and Design

Sime J.D. (1985) The Outcome of Escape Behaviour in Summerland Fire: Panic or Affiliation, in Conference Proceedings, International Conference on Building Use and Safety Technology, National Institute of Building Sciences, Washington.

Jones. B.K. and Hewitt A.J. See (Response and Warning)

Sime, J.D. (1985) Designing for People or Ball Bearings, Portsmouth Polytechnic, UK

MacLennan H, Sime J.D., Pauls, J.L. Examination and Analysis of Evacuation Trials (via questionnaire and direct observation), UTS, Sydney

Nelson H., MacLennan H., (1995) Emergency Movement in (eds Di Nimo, S.J.), Society of Fire Protection Engineers Handbook

Sime J.D., (1994) Spatial analysis of behaviour and movement in the Woolworth Department Store Fire, Manchester: The Urban Experience, IAPS 13 Conference, University of Manchester, 13-15 July (in AS Neary ed. Abstracts)

### REFERENCES FOR Ec - EVACUATION CAPABILITY

Sime J.D (1994) Intelligent buildings for Intelligent People, In Boyd, D., Intelligent Building's and Management, Aldershot, Gower Press, pp 223-235.

Arthur P., Passini, R. (1992) Way finding People Signs and Architecture, McGraw-Hill Ryerson, New York

Sime J.D., (1993) Building Use and Safety - Environmental Cognition and Design, BRE Note N45/93

Garling, J., Gollege, R., (1989) Environmental Perception and Cognition, in Advances in Environment Behaviour and Design (eds. Z Moore and G.T. Moore), Plenum Press, New Zealand

Sixsmith A.J., Sixsmith J.A., Canter D.V. (1989) When is a Door not a Door : A Study of Evacuation Route Design in Large Shopping Malls in (eds) Sime J.D., Safety in the Built Environment, Spon, London

Wiseman G. (1985) Orientation, Path Finding and Architectural Legibility: A Review and Theoretical Integration in Conference Proceedings, International Conference on Building Use and Safety Technology, National Institute of Building Sciences

Passini (1984) Wayfinding in Architecture, Van Nostrand Reinhold, New York

MacLennan H., Pauls, J.L., Sime J.D., (1986-1988) Survey on Building Use and Evacuation, UTS Sydney

Fruin J.J., (1971, 1987) Pedestrian Planning and Design, Metropolitan Association of Urban Designers and Environmental Planners and as revised for Elevation World Educational Services, Mobile Alabama

### REFERENCES FOR Ec, Cc and Rc

## Chapter 12 - Occupant Avoidance

Stahl F. and Archea J. (1977) An assessment of Technical Literature on Emergency Egress from Buildings NBSIR 77-1313 National Bureau of Standards

Nelson, H.E., Levin, B.M., Shike, A.J., Groner, N.E. et al (1983) A Fire Safety Evaluation Scheme for Board and Care Homes, MBSIR 83-2659, US Department of Commerce, National Bureau of Standards Washington DC

Stahl F., Crosson J.J., and Margulis S.T., (1982) Time-based Capabilities of Occupants to Escape Fire in Public Buildings: A Review of Code Provisions and Technical Literature, Report NBSIR 82-2480, National Bureau of Standards

Sime, J. (1983) Affiliative behaviour during escape to Building Exits, Journal of Environmental Psychology, 3(1), pp 21-41

MacLennan, H., Sime J., Pauls J., (1986-1988) Examination and Analysis of Evacuation Trails (via questionnaire and direct observation), UTS, Sydney

Gaartshoe, P., Sime J.D., (1987) Assisted Escape - some guidelines for designers, building managers and the mobility impaired

Pauls, J., (1988) Egress Procedures and Technologies for People with Disabilities, Literature Review, US Architectural Transportation Board

Juillet E., (1993) Evacuating People with Disabilities, Fire Engineering 126, 12, pp 100-103

Shields J., (1991) Fire and the Disabled, Fire Research Centre, University of Ulster, FRS, Borchamwood

### REFERENCES FOR PREDICATION OF EVACUATION SEQUENCE AND TIMES

Latance B., Darley S.M., (1968) Journal of Person and Social Psychology, 10, 215

Fruin J.J., Pedestrian Planning, (1971) Metropolitan Association of Urban Designers and Environmental Planners

McLinek, S.J., Baldwin, R., (1975) Current Paper CP 95/75, BRE, Borehamwood

McLinek, S.J., Booth S., (1975) Current Paper 96/75 BRE Borehamwood

Predtechenskii V.M. and Milinskii A.I., (1978) Planning for Foot Traffic Flow in Buildings, Amerind Publishing Company, New Delhi

Bryan J.I., De Nenzo, P.J. Milke J.A., (1980) the Determination of Behaviour Response Patterns in Fire Situation, NBS, Gaithersburg

Pauls, J.L., (1983) Effective - Width Model for Crowd Evacuation Flow on Stairs, Karlsruhe

Stahl F.I., Crosson J.J, Margulis S.T., (1982) NBSIR 82-2480, NBS Gaithersburg

## Chapter 12 - Occupant Avoidance

Pearson R.G., Joost M.G., (1983) NBSGCR 83429, National Bureau of Standards

Sime J.D., Kimura M., (1988) The timing of escape: exit choice behaviour in fires and building evacuations, (in eds) Sime J., Safety in the Built Environment, Spon, London

MacLennan H., (1989) Regression Analysis of Results from Evacuation Trials, UTS, Sydney

Proulx, G., Sime J., (1989), Appraisal of the Information System in the Sub Surface Stations of Tyne and Wear Metro etc., Tyne and Wear Transport Executive

Sime J.D., Creed C., Kimura, M., and Powell J., (1991) Human Behaviour in fires, BUSRU School and Architecture, Portsmouth Polytechnic, Summary Research Report, Home Office, FRDG, London Publication 2/91

Nelson H.E. MacLennan H. (1995) Emergency Movement (in eds) Di Nenno P.J., SFPE Handbook Fire Protection Engineering, NFPA

Pauls, J.L., (1995) Movement of People (in eds) Di Nenno P J, SFPE Fire Protection Engineering Handbook, NFPA

Bryan J L (1995) Behavioural Response in Fire and Smoke (in eds) Di Nenno, P.J., SFPE Fire Protection Engineering Handbook

Sime J.D., Breaux J. and Canter D, (1994) Human Behaviour Patterns in Domestic and Hospital Fires, BRE Occasional Papers, OP59, Borehamwood: Fire Research Station, BRE

Sime J.D. (1994) Escape Behaviour in Fires and Evacuations (in eds) Stollard P., Johnson L., Design Against Fire: An Introduction to Fire Safety Engineering Design, Melbourne Spon

Sime J.D., (1995) Extensive Private Communication used in development of Chapter 12.

### REFERENCES FOR EVACUATION ANALYSIS - COMPUTER MODELS

Kisko T.M., Francis R.L. and Noble G.R. (1984) EVACNET User's Guide, Department of Industrial and System Engineering, University of Florida Gainesville, Florida

Watts J.M. Jr. (1987) Computer Models for Evacuation Analysis. Fire Safety Journal, 12, 237-245

Fahy R.F. (1993) Exit 89 - an evacuation model for High Rise Buildings, in Interflam '93 Fire Safety Proceedings, pg 519, Interscience Communications Ltd London

Grubits S.F. Shestopal V.O. (1994) Evacuation Model for Merging Traffic Flows in Multi Room and Multi-Storey Buildings (Program Wayout), Seminar, CSIRO-DBCE, Sydney

## Chapter 13 - Fire Brigade Communication and Response

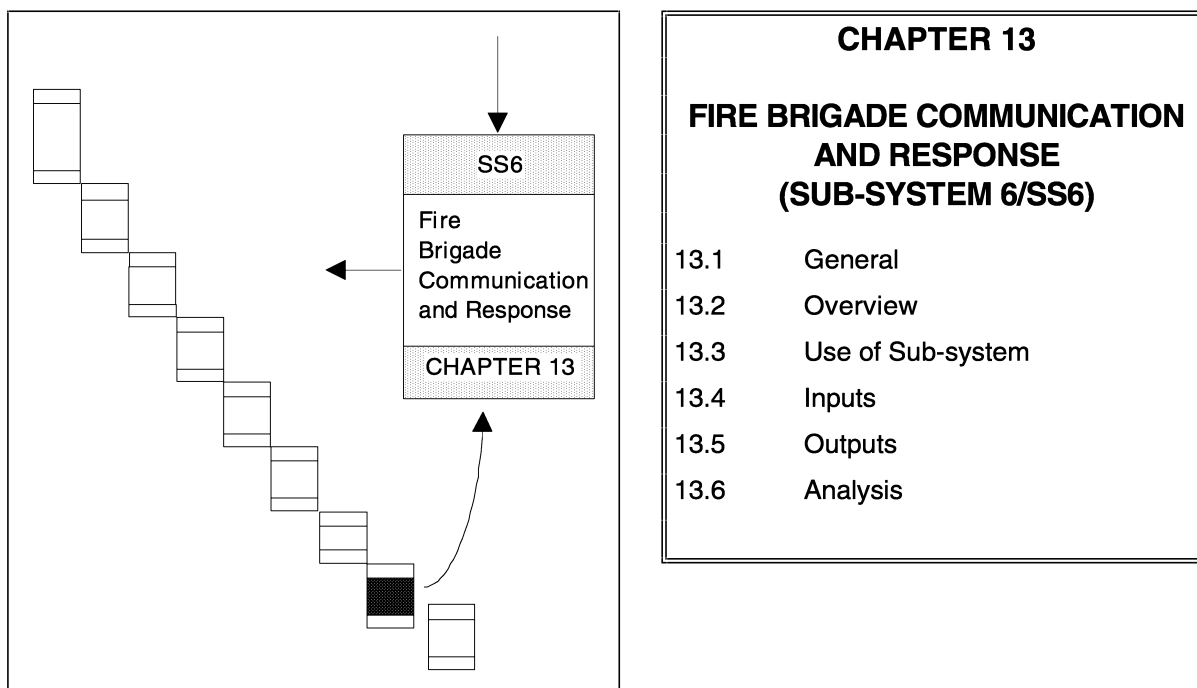

### 13.1 General

This Chapter provides guidance on the evaluation of:

- (a) the arrival time of the fire brigade;
- (b) the time required for fire service set-up;
- (c) the time of fire service attack;
- (d) the fire control time;
- (e) the fire-out time (fire is extinguished).

The effect of fire service activities does not lend itself easily to quantification; therefore, many aspects of the procedure will have to be based on qualitative judgement rather than on numerical calculations. This section may be used to estimate the benefits of fire brigade intervention and when and how these may be taken into account in the design process through a fire engineering analysis.

For most design purposes, it should be assumed that fire service operations do not contribute to the evacuation of occupants. Hence the means of escape provided in the building and the evacuation procedures should ensure that all persons are able to escape without assistance from the fire service; this represents a conservative approach. However, in practice the first concern of the fire service will be to ensure that all persons are safely evacuated (or in a building subject to phased evacuation can safely remain in the building). Therefore, the fire service attack on the fire should normally be assumed to begin only after the evacuation process is complete or, if it is established that the occupants are safe on floors not affected by fire, when all persons are in a place of safety. An analysis of fire service response is, therefore, primarily likely to be of benefit when considering what additional fire protection measures may be appropriate for the purposes of property protection, protection of adjoining facilities and environmental damage.

The influence of fire service activities on the development of the fire is outlined in Chapter 8 (Sub-system 1 / SS1).

## Chapter 13 - Fire Brigade Communication and Response

### 13.2 Overview

#### 13.2.1 Key Events & Times

The key events in the notification, response and suppression performance of the fire brigade are best illustrated in the following time line diagram (Figure 13.1)

Some of these times may be obtained from fire brigades based on their standards of fire cover. For example, the time interval ( $t_a - t_d$ ) is travel time and conservative values based on advice from the fire brigade can be used to estimate this time period.

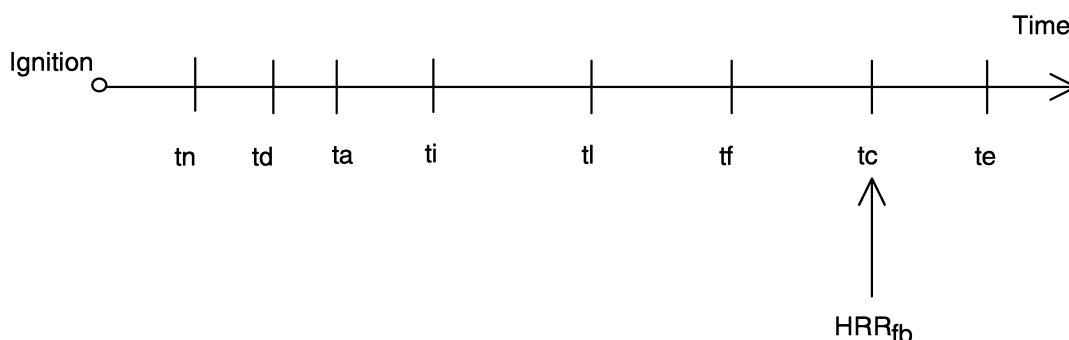

$t_n$	the time when fire brigade is notified of a fire
$t_d$	dispatch time
$t_a$	arrival time
$t_i$	time to complete investigations upon arrival
$t_l$	time to complete life saving/rescue activities
$t_f$	commencement of fire attack
$t_c$	time at which fire is controlled
$t_e$	TIME FIRE IS EXTINGUISHED
$HRR_{fb}$	heat release rate of fire that can be controlled

**Figure 13.1 Key events in fire brigade performance analysis**

The time to complete setup for fire attack and time to complete life saving/rescue activities are scenario dependent. In some cases, there may be no occupants, so evacuation is known to be complete and fire fighters can commence setup immediately. In other cases, there may be considerable delay in setting up and commencement of fire attack because of the need to assist in evacuation or complete search and rescue activities.

The fire size or heat release rate of the fire that can be controlled by the first arriving fire fighters depends on access, the building configuration, water supply and other factors. For conservative design the success of fire brigade in controlling the fire to a limited area will be determined by whether they start their fire attack before or after flashover in the room of fire origin. For large spaces, such as factories and warehouses, success will be determined by whether fire-fighters can contain fire to a limited section of the building.

As for all other suppression systems, the effect of fire fighting activities is expressed in terms of the effect suppression has on the heat release rate. This is

## Chapter 13 - Fire Brigade Communication and Response

illustrated in Figure 13.4. After initial attack at  $t_a$ , the fire may be controlled at  $t_c$ , and if fire brigade is even more effective may result in fire extinguishment at  $t_e$ .

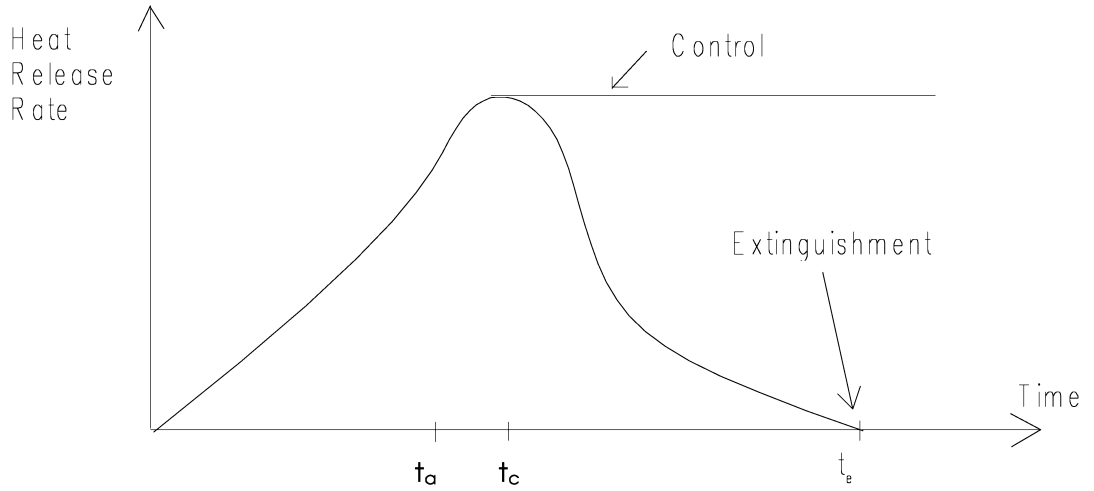

- $t_a$       arrival time
- $t_c$       time at which fire is controlled
- $t_e$       time fire is extinguished

**Figure 13.2 Fire brigade control and extinguishment**

In order to determine these times and the capability of the fire brigade required to achieve effective control on extinguishment, an analysis is required as set out diagrammatically in the flow chart outlined in Figure 13.3.

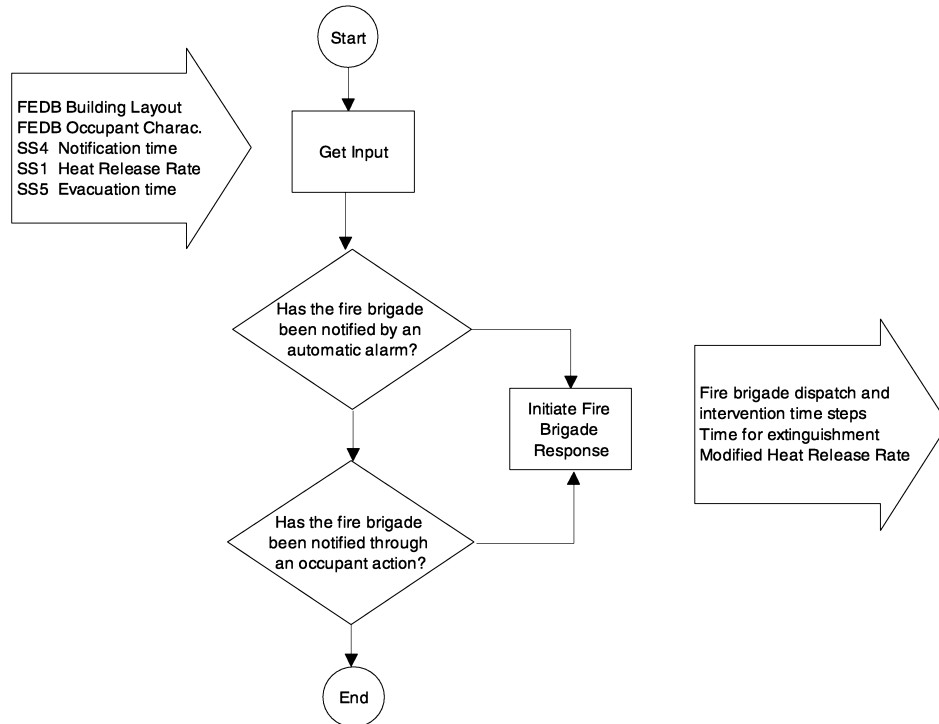

**Figure 13.3 Fire Brigade Communication and Response Flow Chart**



## **Chapter 13 - Fire Brigade Communication and Response**

### **13.3. Use of Sub-system**

#### **13.3.1 General**

The flow chart in figure 13.3 illustrates the procedures that should be applied to the analysis of the performance of fire brigade in fire suppression.

The schematic shows that input of the time to notification of the fire brigade is required from the fire detection analysis in SS4.

Similarly, the output on the change in heat release rate of the fire as a result of fire brigade action may also be taken into account in SS1. However, it is recognised that in many designs, it may be assumed that the brigade will not be able to influence the early stages of fire growth.

### **13.4 Inputs**

#### **13.4.1 Notification time ( $t_n$ )**

Account should be taken of the time at which the alarm call is received at the fire station, allowing for any delays in call handling, etc. Notification may be by automatic fire alarm system (see Section 11.2.9.6) or by human detection and message (usually via telephone) to the fire brigade. This time will come from sub-system 4 (Chapter 11).

#### **13.4.2 Building location and access**

The location of the building with respect to the fire station and access, particularly on extended sites of many buildings, will determine arrival time. This should be reviewed during the FEDB and any deficiencies or advantageous arrangements considered.

#### **13.4.3 Building size, layout**

The size and configuration of the building as well as signage and other factors will determine the time required to investigate the location of the fire upon arrival. The period will include locating and interrogating the fire indicator panel (FIP) to determine the exact fire location. This input should come from building characterisation (Chapter 7).

#### **13.4.4 Evacuation time**

An estimate should be made of the time needed for all occupants to leave the building, so allowing fire fighters to enter and attack the fire. Where the evacuation is phased or horizontal or includes refuges, the escape time i.e. the time to evacuate a compartment (rather than the whole building), may be needed. This time for evacuation or escape can be obtained from SS5 (Chapter 12).

#### **13.4.5 Building occupancy, type, population and time of day**

These factors, along with building size and layout will affect the time taken by the fire brigade to complete any search and rescue activities. These factors come from Building Characterisation (Chapter 7).

## **Chapter 13 - Fire Brigade Communication and Response**

### **13.4.6 Hydrant layout**

Account should be taken, in the FEDB, of the position and characteristics of fire hydrants and other fire brigade facilities that will contribute towards the efficiency of fire fighting operations.

### **13.4.7 Heat release rate ( $HRR_{fb}$ )**

The fire suppression capability of the fire brigade will be dependent on the fire size and heat release rate that the fire fighters find at the time of attack. Data on heat release rate is provided in Sub-system 1 (Chapter 8).

## **13.5 Outputs**

### **13.5.1 General**

Outputs from fire brigade analysis include a number of intermediate times and final times for fire control and extinguishment. Only some of these times may be important outputs for any particular building design.

### **13.5.2 Dispatch Time**

The time from notification of alarm until the fire brigade vehicles leave the fire station.

### **13.5.3 Arrival Time**

The time when the fire brigade reach the building.

### **13.5.4 Time to Complete Investigations**

Once the FIP has been located and the exact location of the fire determined then investigations are complete and set up and/or rescue can commence.

### **13.5.5 Time to Complete Life Safety/Search Rescue**

Time taken to assist completion of evacuation (if necessary) and rescue of any people injured and/or having difficulty evacuating.

### **13.5.6 Time for Fire Attack**

The fire brigade have to position vehicles and other equipment and get hoses into position during this period of set-up ( $t_a - t_i$ ).

### **13.5.7 Time for Fire Control**

An estimate of the time when the fire is likely to be brought under control, taking into account the limits of the available fire brigade personnel and equipment. As the fire grows and more fire brigade personnel / equipment arrive, the size of fire at the point of control may vary, as will the control time. This may serve as input to SS1.

## **Chapter 13 - Fire Brigade Communication and Response**

### **13.5.8 Time to Fire Extinguishment**

Fires are eventually extinguished by the fire brigade or burn themselves out due to lack of fuel. The time  $t_e$  is the expected time of complete extinguishment by the fire brigade. This may be required as input to SS1.

### **13.5.9 Modified Heat Release Rate**

The action of the fire brigade will be to modify the characteristic fire profile, and the modified heat release rate will be part of a feedback as input to SS1.

## **13.6 Analysis**

### **13.6.1 General**

The methodologies for fire brigade performance in this section are not exhaustive and other procedures may be used if appropriate and justifiable.

Much of the input information is related to fire brigade's standards of fire cover and standard operating procedures. It is important in the FEDB stage that these matters be discussed with the fire brigade, who should be able to provide data for this analysis.

### **13.6.2 Arrival time ( $t_a$ )**

Specific data for arrival time is dependent on the fire brigade's standards of fire cover. Typical times from notification to arrival are 7-8 minutes in major cities in Australia.

In country areas, the dispatch time and travel time may be larger.

Where no specific data is available then the data in Table 13.1, should be used as a conservative approach.

**Table 13.1 Times for fire brigade arrival and set-up (Ref. Draft NBFSSC)**

<b>Environment</b>	<b>Time (minutes)</b>	
	<b>Arrival</b>	<b>Set-up</b>
City	10	20
Country	20	15

[Note: Based on 95% probabilities]

### **13.6.3 Time to complete investigations ( $t_i$ )**

Specific data on the time required to investigate the FIP and find the location of the fire will be building and fire scenario dependent. For conservative design a figure of 2.0 minutes is reasonable but advice from the fire brigade and knowledge of the building and FIP may provide a more definite value for this time.

## **Chapter 13 - Fire Brigade Communication and Response**

### **13.6.4 Time to complete life safety search/rescue ( $t_i$ )**

This value is entirely scenario dependent and no formal method for determination of this time exists. If fire brigade arrival occurs after evacuation is complete (sub-system 5), assume this time  $t_i$  is coincident with the time for completion of investigations.

If fire brigade arrival occurs while evacuation is still occurring, assume  $t_i$  occurs when evacuation is complete.

### **13.6.5 Time for fire attack ( $t_a$ )**

Once the brigade has arrived and located the fire origin within the building, and completed any search and rescue activities, then they are in a position to set-up for a fire attack.

The main factors involved in establishing attack time are:

- (a) access to the site
- (b) management patterns
- (c) fire brigade facilities
  - i. water supplies
  - ii. fixed fire fighting facilities
  - iii. equipment carried on fire appliances
  - iv. special fire fighting media
- (d) layout and access within the building
- (e) arrival of sufficient fire appliances and equipment to make an initial attack.

No formal fire engineering methodology exists to determine the attack time. Consequently fire brigade / engineering judgement will be required to quantify this time for the particular building and scenario involved.

In the absence of appropriate data, the conservative values in Table 13.1 should be used for set-up to determine the time of fire attack.

### **13.6.6 Time for fire control ( $t_c$ )**

The fire control time is affected by:

- (a) the operation of fixed fire fighting facilities (e.g.. sprinklers)
- (b) fire fighting by occupants
- (c) the availability of fire fighting media, e.g.. water, foam
- (d) building stability
- (e) the hazards to which fire fighters are exposed
- (f) access for fire appliances / number of fire fighters / appliances / equipment
- (g) fire size

Fire size as a factor is most important. If flashover in the room of fire origin has occurred then effective fire fighting in that room and adjacent rooms will be very difficult. One estimate from UK suggests the maximum fire area controllable by first arriving brigades as 35 m<sup>2</sup>.

Where the fire size (or heat release rate HRR) is greater than the maximum controllable size, the fire is not likely to be controlled until the arrival of supplementary fire appliances in a number sufficient to meet the requirements of a well developed fire.

## Chapter 13 - Fire Brigade Communication and Response

The number of fire fighters, appliances and equipment is dependent upon the standard of fire covers which determines the weight of first attendance and initial attack. Advice on this may be obtained from the fire brigade in the FEDB.

### 13.6.7 Time for fire extinguished ( $t_e$ )

This time will vary widely and will depend on many factors. The fire may be extinguished by automatic means, by the fire brigade, or through total burnout and/or collapse.

Factors to be considered include:

- (a) fire load density and total fire load in the building
- (b) fire resistance
- (c) compartment size

### 13.6.8 Modification of Heat Release Rate

As indicated above, the methodology for analysing fire brigade performance is not well developed. Therefore, the effect of fire brigade action can be conceptual only as illustrated in Figure 13.4.

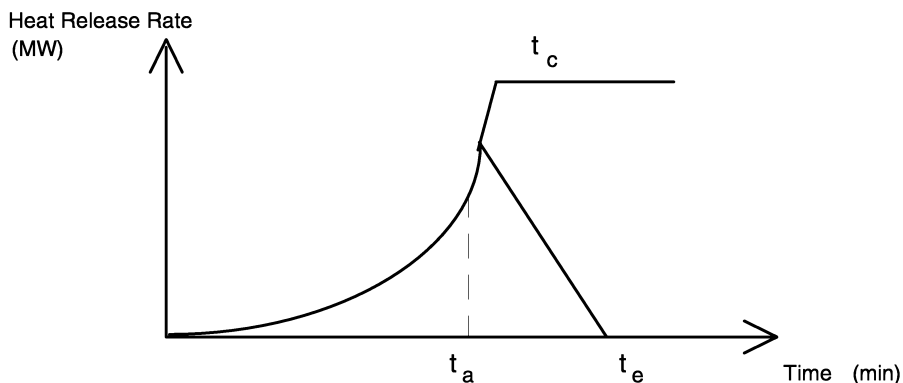

Figure 13.4 Modification of HRR by Fire Brigade

### 13.6.9 Probability Prediction

- (a) General

There is little available in terms of methodologies for establishing the probability of success of the fire brigade in controlling or extinguishing a fire at various stages of fire development. Therefore, fire brigade/engineering judgement will generally be required to establish fire brigade performance.

- (b) Notification

The critical event from a fire brigade performance viewpoint is at what stage in the fire development is the fire brigade notified of a fire condition.

A method by NRCC in Canada provides a general framework. If a fire passes through, for example, 3 stages when notification could occur then the overall probability of fire brigade notification  $P(\text{FBN})$  would be given in the expression:

## **Chapter 13 - Fire Brigade Communication and Response**

$$P(\text{FBN}) = P(\text{Call 1}) + P(\text{Call 2}) + P(\text{Call 3}) \quad (13.1)$$

Where  $P(\text{Call 1})$  is the probability of notification in stage 1 of the fire,  $P(\text{Call 2})$  is stage 2, etc.

Typically stage 1 might be a small fire when an occupant might call the fire brigade, stage 2 might be a slightly larger fire that activates an automatic call from a smoke or heat detector, and stage 3 may be an automatic sprinkler alarm.

Based on these probabilities, the NRCC method provides for a weighted time to fire brigade notification in accordance with the formula:

$$t_{\text{FBN}} = [P(\text{Call 1}) \times t_1 + P(\text{Call 2}) \times t_2 + P(\text{Call 3}) \times t_3] / P(\text{FBN}) \quad (13.2)$$

where  $t_1$ ,  $t_2$  and  $t_3$  are typical times of detection and alarm to the fire brigade in the 3 stages by, for example, occupants, smoke detectors and automatic sprinklers.

### (c) Arrival, set-up and extinguishment

The draft NBFSSC sets out a methodology for estimation of some of these probabilities. They are considered reasonably conservative estimates, but have no strong statistical support.

The WPI/Fitzgerald risk assessment approach also has methodology for establishing the performance of the fire brigade using probabilities. The key factor affecting arrival, set-up control and extinguishment are identified in a systematic framework for evaluation.

The WPI/Fitzgerald methods highlights the fact the fire brigade performance is time and hence fire size dependent. It is suggested in this method that the probability that the fire brigade will arrive and be able to mount a fire attack before flashover is less than 0.4 for most buildings.

# APPENDICES

**APPENDIX 3A**

**DATA / INFORMATION INTERCHANGE BETWEEN SUB-SYSTEMS**

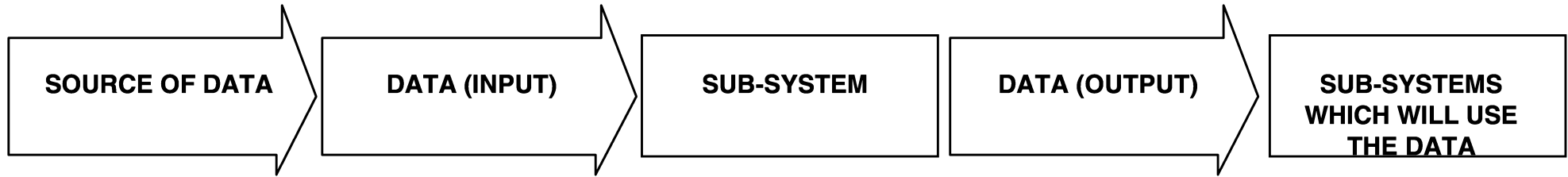

		<b>FEDB</b>	AUTOMATIC DETECTION CHARACTERISTICS	SS4, SS5
			BUILDING CHARACTERISTICS	SS2, SS6
			BUILDING LAYOUT	SS3, SS5
			CRITERIA	SS3
			ENCLOSURE BOUNDARIES	SS3
			ENCLOSURE GEOMETRY	SS1, SS2, SS3
			ENCLOSURE OPENINGS	SS1
			ENVIRONMENTAL EFFECTS	SS2, SS3
			FIRE SCENARIO	SS1
			HUMAN DETECTION CHARACTERISTICS	SS4
			NATURE OF FUEL	SS1
			OCCUPANT CHARACTERISTICS	SS5, SS6
			SEPARATION DISTANCES	SS3
<b>FEDB</b>	FIRE SCENARIO		RHR(t)	SS2, SS3, SS6
	NATURE OF FUEL		FLASHOVER TIME	
	ENCLOSURE GEOMETRY		CHARACTERISTIC FIRE PROFILE	SS2
	ENCLOSURE OPENINGS		SMOKE YIELD	SS2
<b>SS2</b>	HOT LAYER TEMPERATURE	<b>SS1</b>	TOXIC SPECIES YIELD	SS2
<b>SS3</b>	SUPPRESSION ACTIVATION			
<b>SS4</b>	FIRE FIGHTING COMMENCEMENT			
<b>S55</b>	BREAKAGE OF GLAZING			
	NEW OPENINGS			



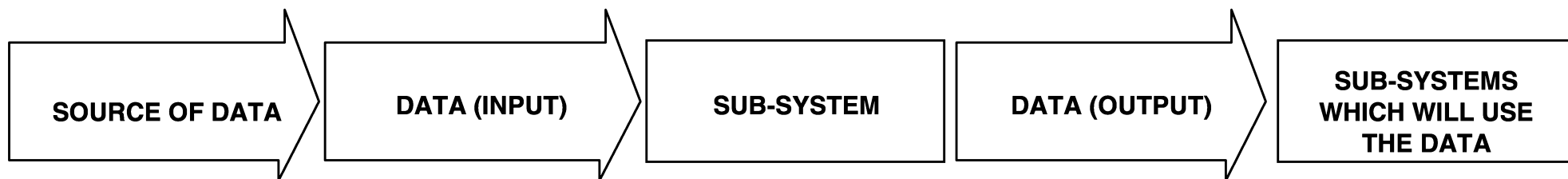

FEDB	ENCLOSURE GEOMETRY	SS2	SMOKE CONTROL ACTIVATION	SS4, SS5	
	BUILDING CHARACTERISTICS		DEPTH OF HOT LAYER		
	ENVIRONMENTAL EFFECTS		TEMPERATURE OF HOT LAYER	SS4, SS5	
SS1	CHARACTERISTIC FIRE PROFILE		TOXIC SPECIES CONCENTRATION	SS5	
	SMOKE YIELD		SMOKE DENSITY	SS4, SS5	
	TOXIC SPECIES YIELD		FLAME SIZE	SS4	
	RHR(t)				
SS4	DETECTOR ACTIVATION				
FEDB	BUILDING LAYOUT		SS3	TIMES AND PROBABILITIES OF SPREAD	
	ENCLOSURE GEOMETRY	TIMES AND PROBABILITIES OF STRUCTURAL FAILURE			
	ENCLOSURE BOUNDARIES				
	SEPARATION DISTANCES				
	ENVIRONMENTAL EFFECTS CRITERIA				
SS1	RHR(t)				
FEDB	AUTOMATIC DETECTION CHARACTERISTICS	SS4	FIRE BRIGADE NOTIFICATION TIME	SS6	
	HUMAN DETECTION CHARACTERISTICS				
SS2	TEMPERATURE PROFILE				
	FLAME SIZE AND TEMPERATURE				
SS3	SMOKE PROFILE				

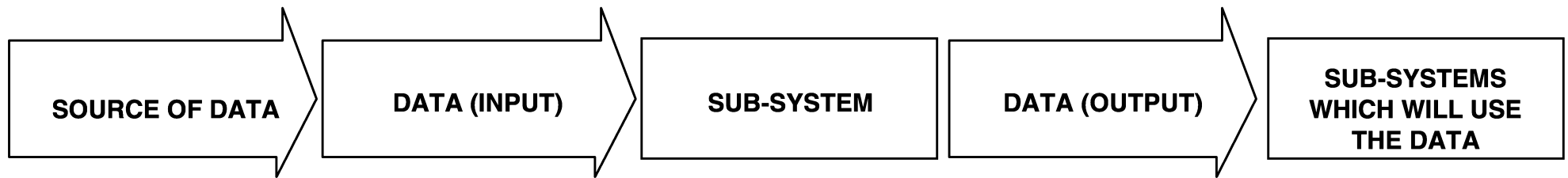

FEDB	BUILDING LAYOUT	SS5	OCCUPANT RESPONSE TIMES	SS6
	OCCUPANT CHARACTERISTICS		OCCUPANT COPING TIMES	
	AUTOMATIC DETECTION CHARACTERISTICS		OCCUPANT EVACUATION TIMES	
SS2	TENABILITY LIMITS			
FEDB	BUILDING LAYOUT	SS6	FIRE BRIGADE DISPATCH AND INTERVENTION TIME STEPS	SS1
	OCCUPANT CHARACTERISTICS		TIME FOR EXTINGUISHMENT	
SS4	NOTIFICATION TIME		MODIFIED HEAT RELEASE RATE	SS1
SS1	HEAT RELEASE RATE			
SS5	EVACUATION TIME			



## **APPENDIX 6A QUANTIFICATION OF UNCERTAINTIES: AN OUTLINE**

NOTE: The following discussion is taken from reference [1].

### **A1. Uncertainty**

Most fields of engineering, including fire safety engineering, have to deal with uncertainty. It is possible to distinguish between two types of uncertainty: knowledge uncertainty, due to lack of fundamental knowledge and variability (randomness) in a population. The former can be reduced by additional fundamental information; the latter cannot be reduced in principle but can be better characterised by exhaustive study. Knowledge uncertainty represents random error, systematic error, irreducible uncertainty, or lack of an empirical basis for making an estimate. It can be addressed, but not necessarily reduced, by better measurements. The two types of uncertainties, however, can be measured by the same method (probability). When dealing with a single element in the population, both types of uncertainty become the same (lack of knowledge) and the risk is characterised by one probability (eg of failure) that represents both types of uncertainty for decision-making purposes. Knowledge uncertainty can be described by a probability distribution. Variability represents heterogeneity across some dimension (population, time, space, etc) that is represented by a frequency distribution. Conceptually, these are very different. Instead of saying that variability and knowledge uncertainty are both described by probability distributions, one should say that they are different but can both be described by probability distributions in many situations, although frequency, in theory, provides an appropriate measure of variability in some situations. [1]

Examples of parameters that are coupled to the two types of uncertainty are given below:

- Variability; wind direction, temperature, fire growth rate
- Knowledge uncertainty; model uncertainty, plume flow coefficient, acceptable heat dose on persons.

It should be noted that several variables could be affected by both kinds of uncertainty. That could be taken into consideration in performing the calculations.

It is important to understand that performance requirements in the fire safety area can be expressed in terms which reflect the underlying uncertainties and the risks involved.

These uncertainties and associated risks are treated explicitly (Level 3) or implicitly (Levels 1 and 2). In Level 2 use is made of safety factors; these factors represent a rather crude method to accounting for uncertainty.

A description of various methodologies which can be used to quantify the effects of uncertainty and variability is given below.

### **A2. Overall treatment of uncertainties**

The factors affecting the reliability of model predictions have been identified as belonging to five distinct categories [2]:

- (1) Uncertainty due to improper definition and conceptualisation of the assessment problem or scenario.
- (2) Uncertainty due to improper formulation of the conceptual model
- (3) Uncertainty involved in the formulation of the computational model
- (4) Uncertainty inherent within the estimation of parameter values, and
- (5) Calculational and documentation errors in the production of results.

The main steps involved in conducting a parameter uncertainty analysis (item 4 above) are:

- (i) List all the parameters that are potentially important contribution to uncertainty in the final model prediction.
- (ii) For each parameter listed, specify the maximum conceivable range of possibly applicable alternative values.
- (iii) Specify the degree of belief (in percentage) that the appropriate parameter value is not larger than specific values selected from the range established in Step 2 above and select a probability distribution that best fits the quoted degrees of belief.
- (iv) Account for dependencies among model parameters by introducing suitable restrictions, by quoting appropriate conditional degrees of belief, or by specifying suitable measures of the degree of association.
- (v) Set up a subjective probability density function (PDF) for the combined range of parameter values. This will subsequently be referred to as a joint PDF. Propagate this joint PDF through the model to generate a subjective probability distribution of predicted values.
- (vi) Derive quantitative statements about the effect of parameter uncertainty on the model prediction.
- (vii) Rank the parameters with respect to their contribution to the uncertainty in the model prediction.
- (viii) Present and interpret the results of the analysis.

Some of the research problems that can be identified and must be looked into include:

- Identify the important sequences of events (scenarios) and respective mathematical submodels.
- Identify type of uncertainty inherent in input parameters (variability, knowledge uncertainty or combined). Use expert opinion or subjective judgement to derive the correspondence subjective distribution functions.
- Estimate model variability.
- Using Monte Carlo simulation techniques combined with response surface methodology perform analysis of total uncertainty, importance analysis and sensitivity analysis.

### A3. Outline of calculation example

To make the following somewhat less abstract a basic calculation example is introduced. The building type is an assembly hall and the study of the analysis is the available safe egress time (ASET) margin for a fire in the assembly room itself. The scenario event tree is shown by Figure A1, outlining the various outcome cases for functioning/non-functioning fire alarms, sprinklers and emergency doors. The event tree indicates the routes by which the initial event (including evacuation) can develop. At each branch, a question is posed related to the development of the event and branch probabilities are assigned, based on statistical data. Each path through the event tree defines a scenario, and accordingly the event tree in Figure A1 defined eight scenarios 1- 8.

The safety limit state equation can be formulated as follows:

$$g = S - D - R - E \geq 0 \quad (A1)$$

where

S = time for smoke filling to 1.9m above floor level

D = detection time

R = response and behaviour time prior to evacuation

E = movement

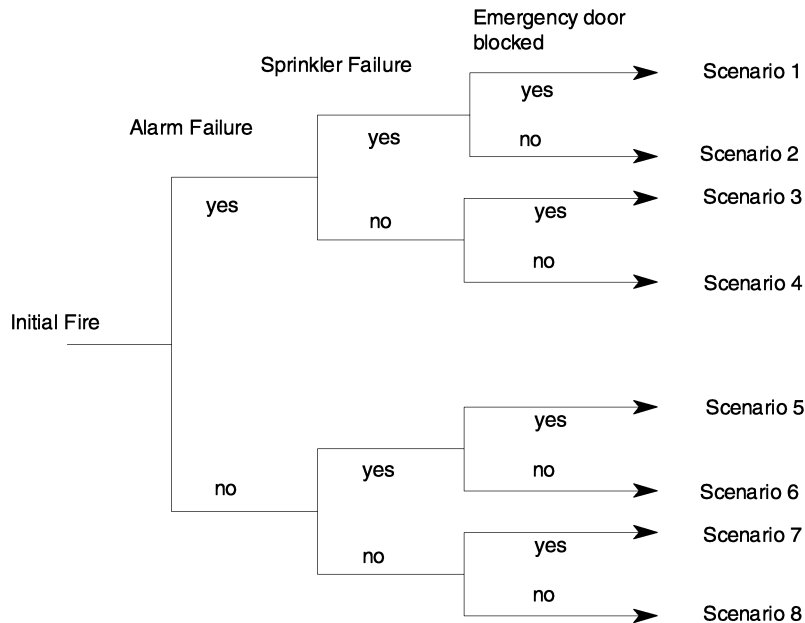

**Figure A1 Event tree describing the eight scenarios**

Considering Equation A1 and the event-tree depicted in Figure A1 it is possible to outline a number of approaches for a risk and uncertainty analysis, for example:

- (1) Analyse a single scenario with a single limit state described by an analytical expression, derived by a suitable method, and with an uncertainty analysis included
- (2) Analyse a single scenario with a computer program and with an uncertainty analysis included
- (3) Analyse the whole event tree (8 scenarios) with each scenario described by an analytical expression and without explicit treatment of uncertainties (possibly including a sensitivity analysis of branch probabilities).
- (4) Using the same analytical expressions as in (3) but including an uncertainty analysis. The main categories of uncertainty would be branch probability uncertainties, parameter and model uncertainties.
- (5) Using computer programs analyse the whole event-tree in Figure A1.

The analytical equation mentioned previously in (1), (3) and (4) could basically be of two kinds:

- (a) physically derived (and preferably non-dimensional) correlation. Examples could be mass flow in plumes, smoke-filling times, radiation from flames
- (b) response surface equations describing output from a computer program. The use of meta-models or response surface expressions is explicitly mentioned in ASTM-standard E1355-90 "Standard Guide for Evaluating the Predictive Capability of Fire Models" [3].

A number of approaches to uncertainty analysis will be identified. In order to structure the treatment and describe the use of the alternative approaches as transparently as possible, Figure A2 may be useful. The figure outlines a possible classification system for the risk assessment procedures, denoted method A - E herein.

The classification system starts by asking if the assessment problem is described by analytical expression(s). If the answer is no, ie the calculation is made numerically by a computer program, available techniques have been described (for example, in references 4 and 5). If the answer is yes, the next question considers the number of limit state equations. If the number is one, two complementary risk prediction methods are available, the analytical First Order Second Moment (FOSM) approach (Method A) and the Monte Carlo simulation approach.

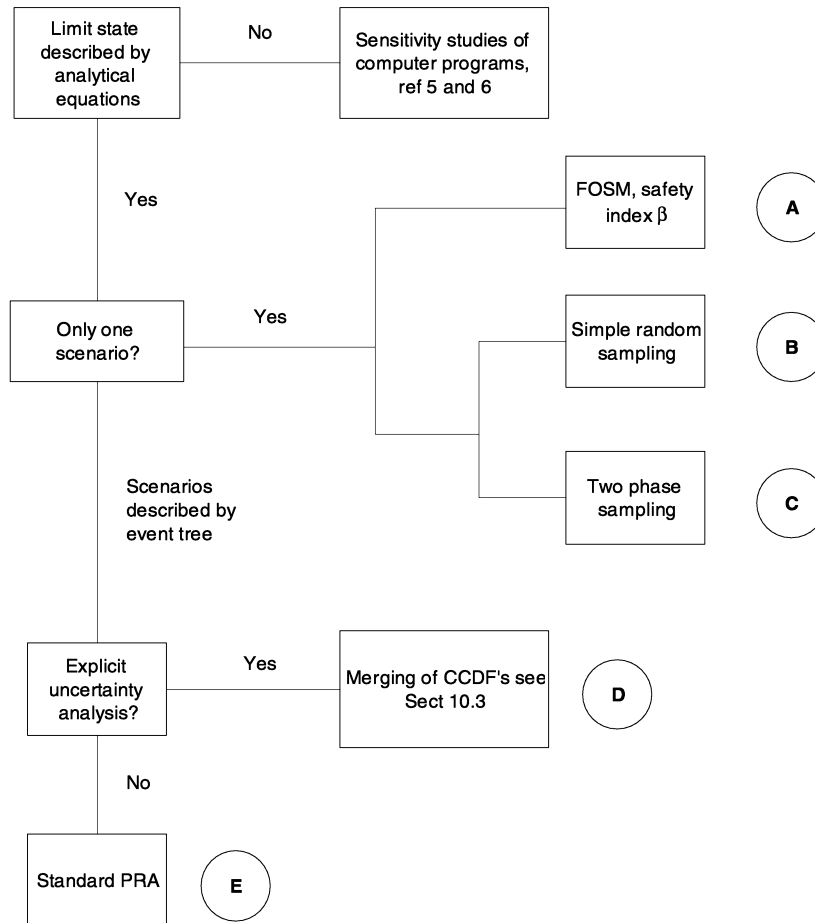

**Figure A2 Different risk assessment procedures**

Here a distinction is made between two Monte Carlo simulation procedures:

- simple random sampling without separation of variability and knowledge uncertainty (Method B)
- two phase sampling procedure, involving simple random sampling and Latin hypercube sampling and with a separation between variability and knowledge uncertainty (Method C).

If we are simultaneously considering more than once scenario, that is, an event-tree situation, the next question concerns the overall treatment of uncertainties. If these are not explicitly taken into account, use will be made of what may be described as standard risk assessment, characterised by omitting uncertainty analyses; this is denoted as Method D. A crude and elementary uncertainty analysis of the event tree in Figure A1 will be termed Method E and is described in [1]. Even if the system is described as an event tree it is possible to use the “analytical” method FOSM in

deriving the relevant parameters. It is then necessary to use rather complex computer programs in solving the system. This will not be done herein.

In the following sections a brief outline will be given of Methods A - E. Before doing this, it is necessary to briefly summarise the concepts of uncertainty and variability, the description of a stochastic model including output from model calculation and methods of uncertainty analysis.

**A4. Outline of calculation and simulation methods for methods A - E**

**A4.1 General Outline**

Methods to propagate uncertainty and to calculate the final measure of risk, step (v) in Section A2, differs for the Methods A - E outlined by Figure A2. An important step of the uncertainty analysis involves propagation through the model of the joint distribution of the uncertain parameters to produce a distribution of model predictions, that is, to derive the PDF or some other statistical representation of the model prediction. The general situation is outlined in Figure A3, taken from reference 2. For example, the model prediction Y in Figure A3 can be used to describe the safety limit state equation (Equation A1).

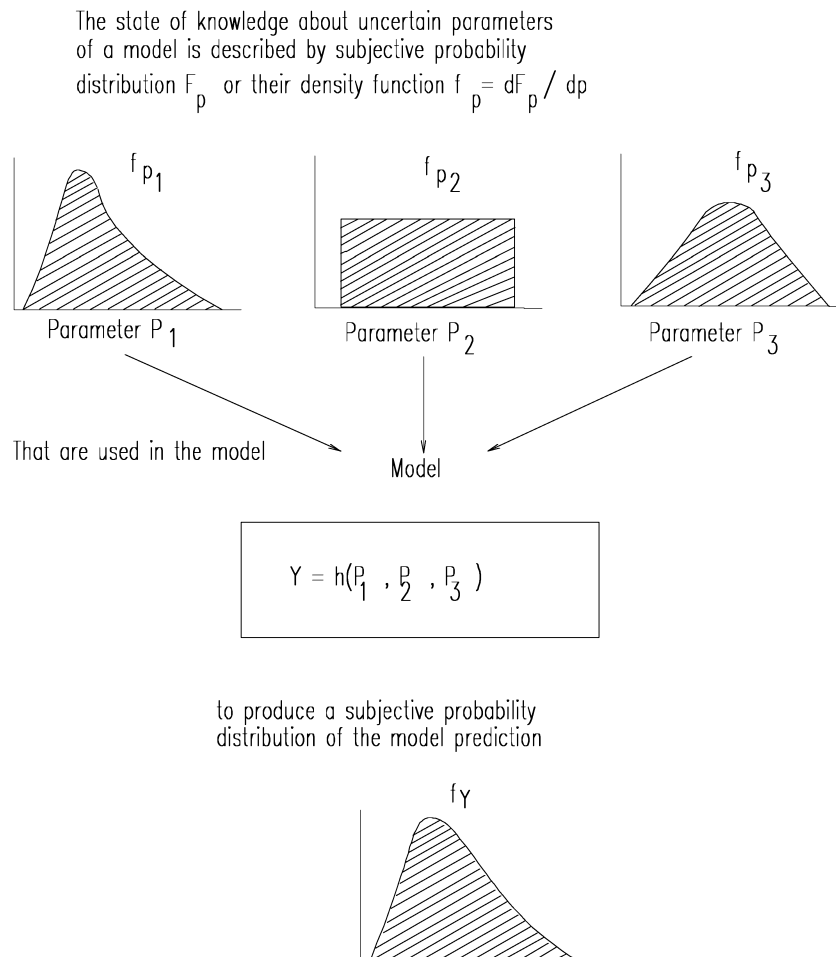

**Figure A3 A diagrammatic sketch of Step v (propagation of parameter uncertainties through the model) of a parameter uncertainty analysis of a deterministic model prediction**



#### A4.2 Method A. The analytical safety index $\beta$ methodology

In this section an outline is given of the supply-demand R-S reliability-based format and the definition of  $\beta$ . The term reliability is here defined as the probabilistic measure of assurance of performance. The further discussion necessitates introduction of some of the concepts used in assessment of reliability and design based on reliability. The description will be strongly condensed and incomplete and for further information the reader is referred to standard textbook such as the one by Ang-Tang [6].

For many fire safety engineering components or subsystems the performance may be reformulated in the following way. Let the random variables R and S be defined:

R = supply capacity  
S = demand requirement

The objective of the reliability analysis is to ensure the event  $R>S$  expressed in terms of the probability  $P(R>S)$ . If the probability distributions of R and S are statistically independent, the probability of failure  $p_F$  may be calculated by

$$p_F = \int_0^{\infty} F_R(s) f_s(s) ds \quad (A2)$$

where F and f denote the cumulative distribution and frequency functions.

If R and S are normal random variable the distributions of the safety margin, M; then

$$M = R-S \quad (3)$$

is also normal =  $N(\mu_M, \sigma_M)$

The parameter  $(M - \mu_M)/\sigma_M$  is  $N(0,1)$  and

$$p_F = F_M(0) = \Phi\left(-\frac{\mu_M}{\sigma_M}\right) = 1 - \Phi\left(\frac{\mu_M}{\sigma_M}\right) \quad \text{or} \quad (Aa)$$

$$p_F = 1 - \Phi(\beta) \quad (Ab)$$

with  $\Phi$  = cumulative probability function of a standard normal variate. The quantity  $\beta = \mu_M/\sigma_M$ , which determines reliability  $p_s = 1-p_F$ , is often called reliability or safety index  $\beta$ . By definition,  $\beta$  is the safety margin expressed in units of  $\sigma_M$ .

The FOSM method has the advantage of directly producing the most probable failure point, that is the design point. The other methods based on Monte Carlo (MC) simulations do not give this point. The MC methods can provide with other relevant information such as the probability distribution of the safety margin.

#### A4.3 Methods B and C. The use of Monte Carlo simulation studies

In modern quantitative risk analysis, Monte Carlo simulation studies employ a central role. Historically, Monte Carlo methods have been regarded only as a last resort to be used only when analytical methods are not available or applicable, the reasons being firstly the need to write your own software, secondly computer calculating capacity. Modern computers combined with easily obtained and easy-to-use commercial software has fundamentally changed the situation.

Applying Monte Carlo methods to the situation outlined in Figure A3 is conceptually straightforward and implies drawing a triplet of values from the three density functions  $f_{p1}$ ,  $f_{p2}$ ,  $f_{p3}$  and calculate a Y value. By repeating this exercise a large number of times, say 5,000, an approximation of density  $f_Y$  is obtained and can be treated and analysed by all available statistical methods. The triplet set is called a sample and it is convenient to consider two kinds of sampling procedures, simple random sampling (SRS) and Latin hyper cube sampling (LHS). A description of these sampling procedures and the reason for choosing both these procedures is presented in Reference1.

#### A4.4 Method D, standard PRA-methodology

The term "fire scenario" is used to describe both the ways in which each developing fire may be detected and alarm given. The term "scenario" is synonymous with a specific event sequence through an event tree.

An event tree is a graphical logical model that identifies and quantifies possible outcomes following an initiating event and provides a systematic coverage of the time sequence of event propagation. At each node, two or more alternatives are analysed until a final outcome is obtained for each node. Each node corresponds to a conditional probability of some outcome if the preceding event has occurred. The frequency of each outcome may be determined by multiplying the initiating event frequency with the conditional probabilities along each path leading to that outcome. A common procedure to represent the information obtained by an event tree is by a complementary cumulative distribution function.

### References

Magnusson, S E, Frantzich, H, Harada, K (1995). Fire safety design based on calculations, Draft Version, Department of Fire Safety Engineering, Lund University, Sweden, June.

IAEA Safety Series No 100 Evaluating the reliability of predictions made using environmental transfer models IAEA, Vienna (1989), ISBN 92-0-124089-9.

Standard guide for evaluating the predictive capability of fire models (1990). ASTM E 1355-90, ASTM Philadelphia.

Iman, R L and Helton, J (1988). An investigation of uncertainty and sensitivity analysis techniques for computer models, Risk Analysis, Vol 8 No 1.

Helton, J (1994). Treatment of uncertainty in performance assessments for complex systems, Risk Analysis, Vol 14, No 4.

Ang, A H-S, Tang, W H (1984). Probability concepts in engineering planning and design, Volume II, John Wiley & Sons.



## APPENDIX-6B -Risk Assessment

NOTE: the following discussion is taken from Reference [1].

The objective of the risk assessment is to evaluate the risk to life in a proposed design and to determine whether the building is at least as safe as one which conforms to the BCA. To do this, a model of what happens after a fire starts must be developed. Such a model describes the events which may follow (fire spread, alarms, occupant response) and how they are related in time. For example, untenable conditions in an enclosure must follow spread of smoke or fire to that enclosure; response of an occupant to an alarm must follow the activation of that alarm. The degree of detail included in the model is a matter of judgement: too little detail will result in inaccuracy, too much detail may produce a model which is excessively difficult to solve. The guiding principle is to design a model so that the data required by it are, wherever possible, readily available from experiments or historical data.

To assess the risk to life, the probability of a sequence of events and the number of deaths resulting are needed. The probability is obtained by multiplying together the probability of occurrence for each event in the fire scenario (eg. the likelihood that doors will be open to facilitate fire spread). The number of deaths depends on the order in which events occur.

It remains to actually calculate the risk to life. The model can be visualised as an event tree. Each event that may or may not happen adds two branches of possibilities to the tree. The end of each branch represents the conclusion to a possible sequence of events in the real world; that is, a fire scenario. The probability of the branch is the product of the probabilities of all the events along its length. To evaluate the expected number of deaths, the probability of the branch is multiplied by the number of deaths resulting from the events on that branch, and these are summed over all branches.

If a time is assigned to each event (should it occur), this ordering is easily determined. Unfortunately, this can lead to the neglect of significant risks, if the events, in reality, could occur anywhere within a range of times. To demonstrate this, consider the following two events: untenable conditions occur in the stairs and a person from the storey above the fire enters the stairs to escape. If the first event is assigned a time of 30 minutes after fire starts and the second is assigned 25 minutes, the model will predict no deaths. However, if untenability may occur between 20 and 40 minutes, and escape between 20 and 30 minutes, there is a risk to life. To assess the risk of such possibilities, it is appropriate to model events which may occur within a range of times.

A difficulty can arise, namely calculating the probability that events occur in a particular order, for example, that either the smoke detector alarm or the sprinkler alarm occurs before the lobby becomes untenable. An exact calculation is possible but it becomes impractical except in the simplest of cases.

The second difficulty is the complexity of the model. Consider for example, if there are over 20 choices to be made of whether or not certain events occur (eg. the sprinklers do or do not operate); in addition, some outcomes will depend on the order in which events occur, further increasing the number of possibilities. So there are well in excess of  $2^{20}$  (or some 1,000,000) endpoints on fire scenarios on the event tree. The majority of these alternatives will represent such a low risk to life that they can be neglected. The problem is to find a solution method which is able to concentrate its effort on the higher risk alternatives. Manual "pruning" of very low probability branches might be possible in some cases.

To allow for events which may be distributed in time, it may be appropriate to model several discrete times of occurrence for a particular event and to attach a probability value to each of these events (for example, the time of occupant response). A more comprehensive approach is to assume that the time of occurrence of events are distributed in time. Under such circumstances it is appropriate to undertake simulation modelling which makes repeated trials, choosing whether and when each event occurs in each trial, and calculates the average number of deaths which occur over a large number of trials. The number of trials required depends on how complex a problem is being modelling and how accurate an answer is required. Much of the data (the probabilities of events or their duration) is not known very accurately. Nevertheless, the complexity is sufficient to necessitate thousands, or even millions, of trials for each branch or fire scenario. This can lead to excessive computational time.

It is not realistic simply to accept the result provided by the simulation model. Some of the data in the model are very difficult to estimate because they correspond to very rare events. This could result in the underestimation of the importance of some sequences of events relative to others and their being swamped in the averaging process by other events.

**Reference [1] :**

I R Thomas, I D Bennetts, S L Poon and J A Sims (1992). The Effect of Fire in the Building at 140 William Street. The Broken Hill Proprietary Company Limited, Report No. BHPR/ENG/R/92/044/SG2C, February.

## APPENDIX 7A

### Fire Load Energy Densities

The following fire load densities (only variable fire load densities) are taken from Beilage 1: Brandschutztechnische Merkmale verschiedener Nutzungen und Lagergüter and are defined as density per unit floor area ( $\text{MJ}/\text{m}^2$ ).

Note that for the determination of the variable fire load of storage areas, the values given in the following table have to be multiplied by the height of storage in meters. Areas and aisles for transportation have been taken into consideration in an averaging manner.

The values are based on a large investigation carried out during the years 1967 - 1969 by a staff of 10 - 20 students under the guidance of the Swiss Fire Prevention Association for Industry and Trade with the financial support of the government civil defence organisation.

For each type of occupancy, storage and/or building, a minimum of 10 - 15 samples were analysed: normally 20 or more samples are available. All values given in the following pages are average values. Unfortunately, it has been impossible to obtain the basic data sheets of this investigation. In order to estimate the corresponding standard deviations and the 80% - 90% and 95% fractile values, the data from this source were compared with data given in various sources. This comparison results in the following suggestions:

(a) For well defined occupancies which are rather similar or with very limited differences in furniture and stored goods, eg dwellings, hotels, hospitals, offices and schools, the following estimates may suffice:

Coefficient of variation	= 30% - 50% of the given average value
90% fractile value	= (1.35 - 1.65) x average value
80% fractile value	= (1.25 - 1.5 ) x average value
Isolated peak values	= 2 x average value

(b) For occupancies which are rather dissimilar or with larger differences in furnishings and stored goods, eg shopping centres, department stores and industrial occupancies, the following estimates are tentatively suggested:

Coefficient of variation	= 50% - 80% of given average value
90% fractile value	= (1.65 - 2.0) x average value
80% fractile value	= (1.45 - 1.75) x average value
Isolated peak values	= 2.5 x average value

Type of occupancies	Fabrication (MJ/m <sup>2</sup> )	Storage (MJ/m <sup>2</sup> /m)	Type of occupancies	Fabrication (MJ/m <sup>2</sup> )	Storage (MJ/m <sup>2</sup> /m)
Academy	300		Bed sheeting production	500	1000
Accumulator forwarding	800		Bedding plant	600	
Accumulator mfg	400	800	Bedding shop	500	
Acetylene cylinder storage	700		Beer mfg (brewery)	80	
Acid plant	80		Beverage mfg, nonalcoholic	80	
Adhesive mfg	1000	3400	Bicycle assembly	200	400
Administration	800		Biscuit factories	200	
Adsorbent plant for combustible vapours	>1700		Biscuit mfg	200	
Aircraft hangar	200		Bitumen preparation	800	3400
Airplane factory	200		Blind mfg, venetian	800	300
Aluminium mfg	40		Blueprinting firm	400	
Aluminium processing	200		Boarding school	300	
Ammunition mfg	special		Boat mfg	600	
Animal food preparing, mfg	2000	3300	Boiler house	200	
Antique shop	700		Bookbinding	1000	
Apparatus forwarding	700		Bookstore	1000	
Apparatus mfg	400		Box mfg	1000	600
Apparatus	600		Brick plant, burning	40	
Apparatus testing	200		Brick plant, clay preparation	40	
Arms mfg	300		Brick plant, drying kiln with metal grates	40	
Arms sales	300		Brick plant, drying kiln with wooden grates	1000	
Artificial flower mfg	300	200	Brick plant, drying room with metal grates	40	
Artificial leather mfg	1000	1700	Brick plant, drying room with wooden grates	400	
Artificial leather processing	300		Brick plant, pressing	200	
Artificial silk mfg	300	1100	Briquette factories	1600	
Artificial silk processing	210		Broom mfg	700	400
Artificial stone mfg	40		Brush mfg	700	800
Asylum	400		Butter mfg	700	4000
Authority office	800				
Awning mfg	300		Cabinet making (without Wood yard)	600	
			Cable mfg	300	600
Bag mfg (jute. paper. plastic)	500		Cafe	400	
Bakery	200		Camera mfg	300	
Bakery. sales	300		Candle mfg	1300	22400
Ball bearing mfg	200		Candy mfg	400	1500
Bandage mfg	400		Candy packing	800	
Bank, counters	300		Candy shop	400	
Bank offices	800		Cane products mfg	400	200
Barrel mfg, wood	1000	800	Canteen	300	
Basement, dwellings	900		Car accessory sales	300	
Basket ware mfg	300	200	Car assembly plant	300	
			Car body repairing	150	

Type of occupancies	Fabrication (MJ/m <sup>3</sup> )	Storage (MJ/m <sup>2</sup> /m)	Type of occupancies	Fabrication (MJ/m <sup>2</sup> )	Storage (MJ/m <sup>2</sup> /m)
Car paint shop	500		Coal cellar	10500	
Car repair shop	300		Cocoa processing	800	
Car seat cover shop	700		Cold storage	2000	
Cardboard box mfg	800	2500	Composing room	400	
Cardboard mfg	300	4200	Concrete products mfg	100	
Cardboard products mfg	800	2500	Condiment mfg	50	
Carpenter shed	700		Congress hall	600	
Carpet dyeing	500		Contractors	500	
Carpet mfg	600	1700	Cooking stove mfg	600	
Carpet store	800		Coopering	600	
Cartwright's shop	500		Cordage plant	300	600
Cast iron foundry	400	800	Cordage store	500	
Celluloid mfg	800	3400	Cork products mfg	500	800
Cement mfg	1000		Cosmetic mfg	300	500
Cement plant	40		Cotton mills	1200	
Cement products mfg	80		Cotton wool mfg	300	
Cheese factory	120		Cover mfg	500	
Cheese mfg (in boxes)	170		Cutlery mfg (household)	200	
Cheese store	100		Cutting-up shop, leather, artificial leather	300	
Chemical plants (rough average)	300	100	Cutting-up shop, textiles	500	
Chemist's shop	1000		Cutting-up shop, wood	700	
Children's home	400				
China mfg	200		Dairy	200	
Chipboard finishing	800		Data processing	400	
Chipboard pressing	100		Decoration studio	1200	2000
Chocolate factory, intermediate storage	6000		Dental surgeon's laboratory	300	
Chocolate factory, packing	500		Dentist's office	200	
Chocolate factory, tumbling treatment	1000		Department store	400	
Chocolate factory, all other specialities	500		Distilling plant, combustible materials	200	
Church	200		Distilling plant, incombustible materials	50	
Cider mfg (without crate storage)	200		Doctor's office	200	
Cigarette plant	3000		Door mfg, wood	800	1800
Cinema	300		Dressing, textiles	200	
Clay, preparing	50		Dressing, paper	700	
Cloakroom, metal wardrobe	80		Dressmaking shop	300	
Cloakroom, wooden wardrobe	400		Dry-cell battery	400	600
Cloth mfg	400		Dry cleaning	300	
Clothing plant	500		Dyeing plant	500	
Clothing store	600				
Coal bunker	2500		Edible fat forwarding	900	
			Edible fat mfg	1000	18900
			Electric appliance mfg	400	
			Electric appliance repair	500	



Type of occupancies	Fabrication (MJ/m <sup>2</sup> )	Storage (MJ/m <sup>2</sup> /m)	Type of occupancies	Fabrication (MJ/m <sup>2</sup> )	Storage (MJ/m <sup>2</sup> /m)
Electric motor mfg	300		Floor covering mfg	500	6000
Electrical repair shop	600		Floor covering store	1000	
Electrical supply storage			Flooring plaster mfg	600	
H< 3 m	1200		Flour products	800	
Electro industry	600		Flower sales	80	
Electronic device mfg	400		Fluorescent tube mfg	300	
Electronic device repair	500		Foamed plastics fabrication	3000	2500
Embroidery	300		Foamed plastics processing	600	800
Etching plant glass/metal	200		Food forwarding	1000	
Exhibition hall, cars including decoration	200		Food store	700	
Exhibition hall, furniture including decoration	500		Forge	80	
Exhibition hall, machines including decoration	80				
Exhibition of paintings			Galvanic	200	
including decoration	200		Gambling place	150	
Explosive industry	4000		Glass blowing plant	200	
			Glass factory	100	
Fertiliser mfg	200	200	Glass mfg	100	
Filling plan/barrels			Glass painting	300	
liquid filled and/or barrels incombustible	<200		Glass processing	200	
liquid filled and/or barrels combustible:			Glassware mfg	200	
Risk Class I	>3400		Glassware store	200	
Risk Class II	>3400		Glazier s workshop	700	
Risk Class III	>3400		Gold plating (of metals)	800	
Risk Class IV	>3400		Goldsmith's workshop	200	
Risk Class V (if higher, take into consideration combustibility of barrels)	>1700		Grain mill, without storage	400	
Filling plan/small casks:			Gravestone carving	50	
liquid filled and casks incombustible	<200		Graphic Workshop	1000	
liquid filled and/or casks combustible:			Greengrocer's shop	200	
Risk Class I	<500		Hairdressing shop	300	
Risk Class II	<500		Hardening plant	400	
Risk Class III	<500		Hardware mfg	200	
Risk Class IV	<500		Hardware store	300	
Risk Class V (if higher, take into consideration combustibility of casks)	<500		Hat mfg	500	
Finishing plant, paper	500		Hat store	500	
Finishing plant, textile	300		Heating equipment room, wood coal firing	300	
Fireworks mfg	special	2000	Heat sealing of plastics	800	

Type of occupancies	Fabrication (MJ/m <sup>2</sup> )	Storage (MJ/m <sup>2</sup> /m)	Type of occupancies	Fabrication (MJ/m <sup>2</sup> )	Storage (MJ/m <sup>2</sup> /m)
Flat	300		Lumber room for miscellaneous goods	500	
High-rise office building	800				
Homes	500		Machinery mfg	200	
Homes for aged	400		Match plant	300	800
Hosiery mfg	300	1000	Mattress mfg	500	500
Hospital	300		Meat shop	50	
Hotel	300		Mechanical workshop	200	
Household appliances, mfg	300	200	Metal goods mfg	200	
Household appliances, sales	300		Metal grinding	80	
			Metal working (general)	200	
Ice cream plant(including packaging)	100		Milk, condensed, evaporated mfg	200	9000
Incandescent lamp plant	40		Milk, powdered, mfg	200	10500
Injection moulded parts mfg (metal)	80		Milling work, metal	200	
Injection moulded parts mfg (plastic)	500		Mirror mfg	100	
Institution building	500		Motion picture studio	300	
Ironing	500		Motorcycle assembly	300	
			Museum	300	
Jewellery mfg	200		Musical instrument sales	281	
Jewellery shop	300	1300			
Joinery	700		News stand	1300	
Joiners (machine room)	500		Nitrocellulose mfg	Special	
Joiner workbench	700		Nuclear research	2100	
Jute, weaving	400	1300	Nursery school	300	
Laboratory, chemical	500		Office, business	800	
Laboratory, electric, electronic	200		Office, engineering	600	
Laboratory, metallurgical	200		Office furniture	700	
Laboratory, physics	200		Office, machinery mfg	300	
Lacquer forwarding	1000		Oilcloth mfg	700	1300
Lacquer mfg	500	2500	Oilcloth processing	700	2100
Large metal constructions	80		Optical instrument mfg	200	200
Lathe shop	600				
Laundry	200		Packing, incombustible goods	400	
Leather goods sales	700		Packing material, industry	1600	3000
Leather product mfg	500		Packing, printed matters	1700	
Leather, tanning, dressing, etc	400		Packing, textiles	600	
Library	2000	2000	Packing, all other		
Lingerie mfg	400	800	combustible goods	600	
Liqueur mfg	400	800	Paint and varnish, mfg	4200	
Liquor mfg	500		Paint and varnish, mixing plant	2000	
Liquor store	700		Paint and varnish shop	1000	
Loading ramp, including goods (rough average)	800		Painter's workshop	500	

Type of occupancies	Fabrication (MJ/m <sup>3</sup> )	Storage (MJ/m <sup>2</sup> /m)	Type of occupancies	Fabrication (MJ/m <sup>2</sup> )	Storage (MJ/m <sup>2</sup> /m)
Pain shop (cars, machines, etc)	200		School	300	
Paint shop (furniture, etc)	400		Seedstore	600	
Paper mfg	200	10000	Sewing machine mfg	300	
Paper processing	800	1100	Sewing machine store	300	
Parking building	200		Sheet mfg	100	
Parquetry mfg	2000	1200	Shoe factory, forwarding	600	
Perambulator mfg	300	800	Shoe factory, mfg	500	
Perambulator shop	300		Shoe polish mfg	800	2100
Perfume sale	400		Shoe repair with manufacture	700	
Pharmaceutical mfg	300	800	Shoe store	500	
Pharmaceutical's, packing	300	800	Shutter mfg	1000	
Pharmacy (including storage)	800		Silkspinning (natural silk)	300	
Photographic laboratory	100		Silk weaving (natural silk)	300	
Photographic store	300		Silverware's	400	
Photographic studio	300		Ski mfg	400	1700
Picture frame mfg	300		Slaughter house	40	
Plaster product mfg	80		Soap mfg	200	4200
Plastic floor tile mfg	800		Soda mfg	40	
Plastic mfg	2000	5900	Soldering	300	
Plastic processing	600		Solvent distillation	200	
Plastic products fabrication	600		Spinning mill, excluding		
Plumber's workshop	100		garneting	300	
Plywood mfg	800	2900	Sporting goods store	800	
Polish mfg	1700		Spray painting, wood prods.	500	
Post office	400		Stationery store	700	
			Steel furniture mfg	300	
Potato, flaked, mfg	200		Stereotype plate mfg	200	
Pottery plant	200		Stone masonry	40	
Power station	600		Storeroom (workshop storerooms etc)	1200	
Precision instrument mfg (containing plastic parts)	200		Synthetic fibre mfg	400	
(without plastic parts)	100		Synthetic fibre processing	400	
Printing, composing room	300		Synthetic resin mfg	3400	4200
Printing, ink mfg	700	3000			
Printing, machine hall	400		Tar-coated paper mfg	1700	
Printing office	1000		Tar preparation	800	
			Telephone apparatus mfg	400	200
Radio and TV mfg	400		Telephone exchange	80	
Radio and TV sales	500		Telephone exchange mfg	100	
Rubber goods store	800		Test room, electric app.	200	
Rubber processing	600	5000	Test room, machinery	100	
			Test room, textiles	300	
Saddlery mfg	300		Theatre	300	
Safe mfg	80		Tin can mfg	100	
Salad oil forwarding	900		Tinned goods mfg	40	
Salad oil mfg	1000	18900	Tinware mfg	120	
Sawmill (without Wood yard)	400		Tyre mfg	700	1800
Scale mfg	400		Tobacco products mfg	200	2100

Type of occupancies	Fabrication (MJ/m <sup>2</sup> )	Storage (MJ/m <sup>2</sup> /m)	Tool mfg	200	
Tobacco shop	500				
Toy mfg (combustible)	100				
Toy mfg (incombustible)	200				
Toy store	500				
Tractor mfg	300				
Transformer mfg	300				
Transformer winding	600				
Travel agency	400				
Turnery (wood working)	500				
Turning section	200				
TV studio	300				
Twisting shop	250				
Umbrella mfg.	300	400			
Umbrellas store	300				
Underground garage, private	>200				
Underground garage, public	<200				
Upholstering plant	500				
Washing machine mfg	300	40			
Watch assembling	300	40			
Watch mechanism mfg	40				
Watch repair shop	300				
Watch sales	300				
Water closets	0				
Wax products forwarding	2100				
Wax products mfg	1300	2100			
Weaving mill (without carpets)	300				
Welding shop (metal)	80				
Winding room	400				
Winding, textile fibres	600				
Window glass mfg	700				
Window mfg (wood)	800				
Wine cellar	20				
Wine merchant's shop	200				
Wire drawing	80				
Wire factory	800				
Wood carving	700				
Wood drying plant	800				
Wood grinding	200				
Wood pattern making shop	600				
Wood preserving plant	3000				
Youth hostel	300				



## APPENDIX 7B

### Statistical Data From The Australian Incident Statistics

Number of fires in various fixed property types from 1 July 1989 to 30 June 1993.

						Adjusted years data				
	89-90	90-91	91-92	92-93	TOTAL	89-90	90-91	91-92	92-93	TOTAL
100 PUBLIC ASSEMBLY PROPERTY, <i>UCF</i>	1	2	3	15	21	1	3	4	18	26
109 PUBLIC ASSEMBLY PROPERTY, <i>NCA</i>	2	5	4	4	15	3	7	5	5	19
110 FIXED AMUSEMENT, <i>IICF</i>	4	0	22	4	30	5	0	27	5	37
111 BOWLING ESTABLISHMENT	12	11	12	6	41	16	15	15	7	52
112 BILLIARD CENTRE	0	2	3	1	6	0	3	4	1	8
113 AMUSEMENT CENTRE	7	10	9	7	33	9	13	11	8	42
116 SWIMMING FACILITY	6	6	8	6	26	8	8	10	7	33
119 FIXED AMUSEMENT PLACE	14	9	10	12	45	19	12	12	15	57
120 VARIABLE USE PLACE, <i>IICF</i>	2	4	0	0	6	3	5	0	0	8
121 BALLROOM, GYMNASIUM	11	19	10	4	44	15	25	12	5	57
122 EXHIBITION, EXPOSITION	27	24	26	9	86	36	32	32	11	110
123 ARENA, STADIUM	33	37	30	30	130	44	49	36	36	166
124 PLAYGROUND	13	22	14	7	56	17	29	17	8	72
129 VARIABLE USE PLACE <i>NCA</i>	6	7	8	8	29	8	9	10	10	37
131 CHURCH, CHAPEL	19	29	28	23	99	25	39	34	28	126
132 RELIGIOUS EDUCATION	4	9	2	3	18	5	12	2	4	23
133 CHURCH HALL	17	23	21	12	73	23	31	25	15	93
134 FUNERAL PARLOUR, CHAPEL	4	4	0	0	8	5	5	0	0	11
140 CLUBS, <i>IICF</i>	0	4	9	5	18	0	5	11	6	22
141 CITY CLUB	47	66	73	51	237	63	88	88	62	301
142 COUNTRY CLUB	14	25	35	29	103	19	33	42	35	130
143 YACHT CLUB	8	4	8	2	22	11	5	10	2	28
149 CLUB, <i>NCA</i>	23	18	26	27	94	31	24	32	33	119
151 LIBRARY	9	7	8	6	30	12	9	10	7	38
152 MUSEUM, ART GALLERY	1	9	4	5	19	1	12	5	6	24
153 HISTORIC BUILDING	3	1	2	2	8	4	1	2	2	10
155 COURT-ROOM	1	8	3	6	18	1	11	4	7	23
160 EATING PLACES, <i>IICF</i>	1	1	1	4	7	1	1	1	5	9
161 RESTAURANT	161	196	216	156	729	215	261	262	189	927
162 NIGHTCLUB	15	17	20	11	63	20	23	24	13	80
163 TAVERN	33	45	34	28	140	44	60	41	34	179
164 LUNCHROOM, DRIVE-IN	72	88	105	103	368	96	117	127	125	465
169 EATING PLACE, <i>NCA</i>	12	7	10	5	34	16	9	12	6	44
171 AIRPORT PASSENGER TERMINAL	6	1	4	1	12	8	1	5	1	15
174 STREET LEVEL RAIL TERMINAL	15	16	13	12	56	20	21	16	15	72
175 UNDERGROUND RAIL TERMINAL	5	6	5	0	16	7	8	6	0	21
176 ELEVATED RAIL TERMINAL	6	4	5	0	15	8	5	6	0	19
177 MARINE PASSENGER TERMINAL	2	8	5	1	16	3	11	6	1	21
181 LEGITIMATE THEATRE	12	2	15	9	38	16	3	18	11	48
182 AUDITORIUM, CONCERT	2	4	6	4	16	3	5	7	5	20
183 MOTION-PICTURE THEATRE	4	8	3	9	24	5	11	4	11	31
184 DRIVE-IN MOTION-THEATRE	0	3	3	1	7	0	4	4	1	9
185 RADIO, TV STUDIO	2	6	6	7	21	3	8	7	8	26
189 THEATRES, STUDIOS <i>NCA</i>	3	2	1	1	7	4	3	1	1	9
200 EDUCATIONAL PROPERTY, <i>IICF</i>	1	5	8	4	18	1	7	10	5	23
209 EDUCATIONAL PROPERTY, <i>NCA</i>	4	8	19	5	36	5	11	23	6	45
210 NON-RESIDENTIAL SCHOOL	5	11	14	17	47	7	15	17	21	59
211 CHILD-MINDING CENTRE	3	7	13	6	29	4	9	16	7	36
212 PRE-SCHOOL KINDERGARTEN	8	15	13	17	53	11	20	16	21	67
213 PRIMARY SCHOOL	107	157	164	137	565	143	209	199	166	717

Appendix 7B (Cont) -Number of fires in various fixed property types from 1 July 1989 to 30 June 1993.

Adjusted years data

	89-90	90-91	91-92	92-93	TOTAL	89-90	90-91	91-92	92-93	TOTAL
214 SECONDARY SCHOOL	43	30	37	23	133	57	40	45	28	170
215 HIGH SCHOOL	59	93	89	116	357	79	124	108	141	451
219 NON-RESIDENTIAL SCHOOL	1	6	14	9	30	1	8	17	11	37
220 RESIDENTIAL SCHOOL, <i>IICF</i>	2	1	1	5	9	3	1	1	6	11
221 RESIDENTIAL SCHOOL CLASSROOM	6	15	23	9	53	8	20	28	11	67
229 RESIDENTIAL SCHOOL <i>NCA</i>	0	1	4	2	7	0	1	5	2	9
231 VOCATIONAL, TRADE SCHOOL	7	7	6	6	26	9	9	7	7	33
232 BUSINESS SCHOOL	2	8	2	0	12	3	11	2	0	16
233 SPECIALITY SCHOOL	2	11	8	2	23	3	15	10	2	29
234 REHABILITATION CENTRE	7	4	0	3	14	9	5	0	4	18
240 COLLEGES, UNIVERSITIES, <i>IICF</i>	2	5	1	3	11	3	7	1	4	14
241 COLLEGE CLASSROOM BUILDING	43	50	82	46	221	57	67	99	56	279
249 COLLEGES, <i>NCA</i>	1	1	6	0	8	1	1	7	0	10
300 INSTITUTIONAL PROPERTY, <i>IICF</i>	3	0	4	2	9	4	0	5	2	11
309 INSTITUTIONAL PROPER, <i>NCA</i>	6	3	6	9	24	8	4	7	11	30
310 CARE OF THE AGED, <i>IICF</i>	7	0	15	1	23	9	0	18	1	29
311 CARE OF THE AGED WITH NURSING	149	190	279	199	817	199	253	338	241	1031
312 CARE OF THE AGED WITHOUT NURSING	8	4	6	7	25	11	5	7	8	32
321 DAY CHILD-CARE CENTRE	8	7	12	13	40	11	9	15	16	50
322 CHILDREN'S HOME, ORPHANAGE	3	2	3	3	11	4	3	4	4	14
329 CARE OF THE YOUNG, <i>NCA</i>	4	6	2	1	13	5	8	2	1	17
330 CARE OF THE SICK, <i>IICF</i>	1	1	5	0	7	1	1	6	0	9
331 HOSPITAL, HOSPITAL-TYPE INFIRMARY	213	310	329	167	1019	284	413	399	202	1299
332 SANATORIUM	3	1	4	3	11	4	1	5	4	14
334 CLINIC, CLINIC TYPE INFIRMARY	15	13	14	17	59	20	17	17	21	75
339 CARE OF THE SICK, <i>NCA</i>	2	4	4	5	15	3	5	5	6	19
341 PRISON CELL, CELL BLOCK	47	46	34	14	141	63	61	41	17	182
342 PRISON CELL, CELL BLOCK	4	3	6	3	16	5	4	7	4	20
343 JUVENILE DETENTION HOME	3	7	3	5	18	4	9	4	6	23
344 DETENTION CAMP, FARM	1	3	3	1	8	1	4	4	1	10
345 POLICE STATION	8	8	17	3	36	11	11	21	4	46
346 COMPULSORY VOCATIONAL CAMP	4	0	1	1	6	5	0	1	1	8
349 PHYSICALLY RESTRAINED, <i>NCA</i>	4	3	1	2	10	5	4	1	2	13
351 INSTITUTION FOR DEAF, MUTE OR BLIND	1	7	0	1	9	1	9	0	1	12
352 INSTITUTION FOR PHYSICAL REHABILITATION	1	7	11	3	22	1	9	13	4	28
359 CARE OF THE PHYSICALLY INCONVENIENCED, <i>NCA</i>	2	2	4	3	11	3	3	5	4	14
360 CARE OF THE MENTALLY HANDICAPPED, <i>IICF</i>	3	1	6	5	15	4	1	7	6	19
361 MENTAL INSTITUTION	37	55	30	20	142	49	73	36	24	183
362 INSTITUTION FOR THE MENTALLY RETARDED	26	31	13	11	81	35	41	16	13	105
369 CARE OF THE MENTALLY HANDICAPPED, <i>NCA</i>	5	11	13	11	40	7	15	16	13	50

Appendix 7B (Cont) -Number of fires in various fixed property types from 1 July 1989 to 30 June 1993.

Adjusted years data

	89-90	90-91	91-92	92-93	TOTAL	89-90	90-91	91-92	92-93	TOTAL
400 RESIDENTIAL PROPERTY, <i>IICF</i>	17	33	22	23	95	23	44	27	28	121
409 RESIDENTIAL PROPERTY, <i>NCA</i>	21	25	34	13	93	28	33	41	16	118
410 FAMILY UNIT, <i>IICF</i>	31	19	123	118	291	41	25	149	143	359
411 ONE FAMILY UNIT: YEARLY USE	5966	6632	7408	6560	26566	7955	8843	8979	7952	33728
412 ONE FAMILY UNIT: SEASONAL USE	49	37	46	37	169	65	49	56	45	215
414 TWO FAMILY UNIT: YEARLY USE	105	116	117	89	427	140	155	142	108	544
415 TWO FAMILY UNIT: SEASONAL USE	5	2	5	5	17	7	3	6	6	21
419 FAMILY UNIT, <i>NCA</i>	26	20	47	37	130	35	27	57	45	163
420 APARTMENTS, <i>IICF</i>	151	204	254	244	853	201	272	308	296	1077
421 ONE OR TWO UNITS WITH BUSINESS	62	52	73	48	235	83	69	88	58	299
422 THREE TO SIX UNITS	248	252	331	259	1090	331	336	401	314	1382
423 SEVEN TO TWENTY UNIT	430	498	492	410	1830	573	664	596	497	2331
424 OVER TWENTY UNITS	439	447	434	203	1523	585	596	526	246	1953
429 UNITS, TENEMENTS, <i>NCA</i>	6	19	39	17	81	8	25	47	21	101
430 ROOMING HOUSES, <i>IICF</i>	28	54	32	47	161	37	72	39	57	205
431 THREE TO EIGHT ROOMERS	29	28	40	24	121	39	37	48	29	154
432 NINE TO FIFTEEN ROOMERS	18	22	22	14	76	24	29	27	17	97
439 ROOMING HOUSES <i>NCA</i>	10	12	20	3	45	13	16	24	4	57
440 HOTELS, MOTELS, <i>IICF</i>	66	80	94	40	280	88	107	114	48	357
441 LESS THAN 20 UNITS: YEARLY USE:	77	49	77	33	236	103	65	93	40	301
442 LESS THAN 20 UNITS: SEASONAL USE	8	17	13	12	50	11	23	16	15	64
443 20 TO 99 UNITS: YEARLY USE	72	39	74	43	228	96	52	90	52	290
444 20 TO 99 UNITS: SEASONAL USE	16	4	8	8	36	21	5	10	10	46
445 100 OR MORE UNITS: YEARLY USE	35	46	56	41	178	47	61	68	50	226
446 100 OR MORE UNITS: SEASONAL USE	2	2	4	10	18	3	3	5	12	22
449 HOTELS, MOTELS <i>NCA</i>	10	13	13	8	44	13	17	16	10	56
461 SCHOOL, COLLEGE, <i>NCA</i>	6	7	12	8	33	8	9	15	10	42
463 NURSE'S QUARTERS	8	14	23	9	54	11	19	28	11	68
464 ARMED SERVICES BARRACKS	4	7	4	1	16	5	9	5	1	21
465 CONVENT OR OTHER RELIGIOUS DORMITORY	3	15	6	5	29	4	20	7	6	37
466 BUNK HOUSE, WORKER'S	0	3	2	2	7	0	4	2	2	9
469 DORMITORIES, <i>NCA</i>	5	3	7	4	19	7	4	8	5	24
481 LESS THAN 20 UNITS: YEARLY USE	19	15	17	17	68	25	20	21	21	87
482 LESS THAN 20 UNITS: SEASONAL USE	1	2	3	1	7	1	3	4	1	9
483 20 TO 99 UNITS: YEARLY USE	7	5	13	10	35	9	7	16	12	44
484 20 TO 99 UNITS: SEASONAL USE	2	2	2	4	10	3	3	2	5	13
485 100 OR MORE UNITS: YEARLY USE	2	5	11	7	25	3	7	13	8	31
489 HOME HOTEL <i>NCA</i>	1	4	1	0	6	1	5	1	0	8
490 OTHER RESIDENTIAL, <i>IICF</i>	0	2	6	3	11	0	3	7	4	14
491 CHILDREN'S PLAYHOUSE	8	2	7	4	21	11	3	8	5	27
492 OUTDOOR SLEEPING QUARTERS	4	5	16	6	31	5	7	19	7	39
499 OTHER RESIDENTIAL <i>NOA</i>	10	9	17	12	48	13	12	21	15	60



Appendix 7B (Cont) -Number of fires in various fixed property types from 1 July 1989 to 30 June 1993.

Adjusted years data

	89-90	90-91	91-92	92-93	TOTAL	89-90	90-91	91-92	92-93	TOTAL
500 MERCANTILE OFFICES, <i>IICF</i>	22	42	50	49	163	29	56	61	59	205
509 MERCANTILE PROPERTIES, <i>NCA</i>	2	1	16	9	28	3	1	19	11	34
510 FOOD STORE, <i>IICF</i>	18	15	12	9	54	24	20	15	11	69
511 SUPERMARKET	54	70	82	72	278	72	93	99	87	352
512 MARKET, GROCERY STORE	27	43	55	26	151	36	57	67	32	192
513 SPECIALITY FOOD STORE	125	138	129	97	489	167	184	156	118	625
514 LIQUOR, BEVERAGE STORE	5	7	7	12	31	7	9	8	15	39
515 CREAMERY, DAIRY STORE	4	2	1	1	8	5	3	1	1	10
516 DELICATESSEN	71	72	77	42	262	95	96	93	51	335
519 FOOD STORE <i>NCA</i>	20	21	21	12	74	27	28	25	15	95
521 CLOTHING STORE	44	40	52	33	169	59	53	63	40	215
522 CLOTHING ACCESSORIES	6	6	7	5	24	8	8	8	6	31
523 SHOE REPAIR STORE	4	1	2	4	11	5	1	2	5	14
524 TAILOR, DRESSMAKER S	3	0	5	2	10	4	0	6	2	12
526 DRY GOODS STORE	4	1	1	1	7	5	1	1	1	9
529 TEXTILE STORE <i>NCA</i>	1	2	2	5	10	1	3	2	6	12
531 FURNITURE STORE	19	27	22	12	80	25	36	27	15	103
532 APPLIANCE STORE	15	23	14	9	61	20	31	17	11	79
533 HARDWARE STORE	17	8	12	5	42	23	11	15	6	54
534 MUSIC STORE	0	3	9	5	17	0	4	11	6	21
535 WALLPAPER, PAINT STORE	5	4	13	10	32	7	5	16	12	40
536 RUG, FLOOR COVERING	6	3	15	6	30	8	4	18	7	37
538 APPLIANCE REPAIR STORE	7	3	3	7	20	9	4	4	8	25
539 HOUSEHOLD GOODS STORE	2	10	5	2	19	3	13	6	2	24
540 SPECIALITY SHOP, <i>IICF</i>	3	11	11	10	35	4	15	13	12	44
541 BOOK, STATIONERY STORE	26	18	21	12	77	35	24	25	15	99
542 NEWS STAND, TOBACCO SHOP	12	11	7	7	37	16	15	8	8	48
543 CHEMIST SHOP	15	15	11	15	56	20	20	13	18	72
544 JEWELLERY SHOP	10	5	2	4	21	13	7	2	5	27
545 GIFT SHOP	8	18	6	2	34	11	24	7	2	44
546 LEATHER GOODS SHOP	3	2	2	0	7	4	3	2	0	9
547 FLORIST SHOP, GREENHOUSE	11	3	9	19	42	15	4	11	23	53
548 OPTICAL GOODS SALES	4	2	1	0	7	5	3	1	0	9
549 SPECIALITY SHOP <i>NCA</i>	32	36	30	27	125	43	48	36	33	160
551 HOBBY, TOY SHOP	6	5	2	6	19	8	7	2	7	24
552 SPORTING GOODS STORE	12	17	14	7	50	16	23	17	8	64
553 PHOTOGRAPHIC SUPPLIES	6	7	4	2	19	8	9	5	2	25
554 GARDEN SUPPLY STORE	6	5	3	1	15	8	7	4	1	20
556 PET STORE, ANIMAL HOUSE	4	8	5	4	21	5	11	6	5	27
557 BARBER, BEAUTY SHOP	25	34	16	13	88	33	45	19	16	114
559 RECREATION, HOBBY <i>NCA</i>	10	6	6	7	29	13	8	7	8	37
560 PROFESSIONAL SERVICE, <i>IICF</i>	0	2	5	0	7	0	3	6	0	9
562 TRADE SUPPLY SALES	3	4	4	9	20	4	5	5	11	25
564 SELF-SERVICE LAUNDRY	21	33	45	21	120	28	44	55	25	152
565 LINEN SUPPLY	3	2	3	6	14	4	3	4	7	18
566 LAUNDRY, DRYCLEANERS	27	16	17	11	71	36	21	21	13	91
568 RESTAURANT SUPPLIES,	4	2	1	2	9	5	3	1	2	12
569 PROFESSIONAL SERVICE, <i>NCA</i>	1	10	2	2	15	1	13	2	2	20

Appendix 7B (Cont) -Number of fires in various fixed property types from 1 July 1989 to 30 June 1993.

Adjusted years data

	89-90	90-91	91-92	92-93	TOTAL	89-90	90-91	91-92	92-93	TOTAL
570 MOTOR, BOAT SALES, <i>IICF</i>	1	0	5	3	9	1	0	6	4	11
571 PUBLIC SERVICE STATION	30	52	53	45	180	40	69	64	55	228
572 PRIVATE SERVICE STATION	2	8	3	2	15	3	11	4	2	19
573 MOTOR VEHICLE REPAIR	71	91	92	77	331	95	121	112	93	421
574 MOTOR VEHICLE, TRAILER SALES	11	27	13	26	77	15	36	16	32	98
575 MOTOR VEHICLE ACCESSORIES	19	25	16	14	74	25	33	19	17	95
579 MOTOR, BOAT SALES <i>NCA</i>	4	2	4	2	12	5	3	5	2	15
580 GENERAL ITEM STORE, <i>IICF</i>	5	9	10	12	36	7	12	12	15	45
581 DEPARTMENT STORE	19	26	13	16	74	25	35	16	19	95
582 SMALL VARIETY STORE	14	15	25	23	77	19	20	30	28	97
583 LARGE VARIETY STORE	55	112	141	106	414	73	149	171	128	522
585 MALL	33	39	46	34	152	44	52	56	41	193
589 GENERAL ITEM STORE <i>NCA</i>	9	9	14	10	42	12	12	17	12	53
590 OFFICES, <i>IICF</i>	6	3	10	6	25	8	4	12	7	31
591 GENERAL BUSINESS OFFICE	357	395	373	271	1396	476	527	452	328	1783
592 BANK	36	55	42	22	155	48	73	51	27	199
593 MEDICAL, RESEARCH, SCIENTIFIC OFFICE	27	46	40	17	130	36	61	48	21	166
594 ENGINEERING, ARCHITECTURAL OFFICE	6	5	6	2	19	8	7	7	2	24
596 POST OFFICE	14	13	21	15	63	19	17	25	18	80
599 OFFICES <i>NCA</i>	9	16	18	13	56	12	21	22	16	71
609 BASIC INDUSTRY <i>NCA</i>	4	0	2	3	9	5	0	2	4	11
615 ELECTRICITY GENERATION PLANT	8	20	6	7	41	11	27	7	8	53
620 LABORATORIES, <i>IICF</i>	0	1	2	3	6	0	1	2	4	7
621 CHEMICAL, MEDICAL LAB	2	2	6	5	15	3	3	7	6	19
622 PHYSICAL MATERIALS TESTING LAB	2	3	2	3	10	3	4	2	4	13
627 GENERAL RESEARCH LAB	2	2	6	0	10	3	3	7	0	13
630 COMMUNICATION SITE, <i>IICF</i>	1	1	2	2	6	1	1	2	2	8
631 NATIONAL DEFENCE SITE	1	10	6	2	19	1	13	7	2	24
632 RADIO, RADAR SITE	3	4	0	2	9	4	5	0	2	12
633 FIRE, POLICE, INDUSTRIAL COMMUNICATION CENTRE	3	2	3	4	12	4	3	4	5	15
634 TELEPHONE EXCHANGE,	14	15	22	14	65	19	20	27	17	82
635 COMPUTER, DATA-PROCESSING CENTRE	8	13	0	1	22	11	17	0	1	29
639 COMMUNICATION SITE N	2	3	2	0	7	3	4	2	0	9
642 ELECTRICITY DISTRIBUTION SYSTEM	20	20	38	31	109	27	27	46	38	137
647 WATER SUPPLY SYSTEM	2	1	2	4	9	3	1	2	5	11
648 SANITARY SERVICE	6	2	2	2	12	8	3	2	2	16
650 AGRICULTURE, <i>NCA</i>	5	4	1	2	12	7	5	1	2	16
651 POULTRY, EGG PRODUCTION	2	2	3	5	12	3	3	4	6	15
652 COW, CATTLE PRODUCTION	2	6	7	11	26	3	8	8	13	32
654 OTHER LIVESTOCK PROD	2	1	5	1	9	3	1	6	1	11
655 CROPS, ORCHARDS	5	6	8	10	29	7	8	10	12	36
657 FRUIT, VEGETABLE PACKING	3	0	2	5	10	4	0	2	6	12
659 AGRICULTURE, <i>NCA</i>	4	1	20	11	36	5	1	24	13	44
666 WOOD CHIP PILE	2	1	2	1	6	3	1	2	1	8

Appendix 7B (Cont) -Number of fires in various fixed property types from 1 July 1989 to 30 June 1993.

	Adjusted years data					Adjusted years data				
	89-90	90-91	91-92	92-93	TOTAL	89-90	90-91	91-92	92-93	TOTAL
673 ORE CONCENTRATION PLANT	3	6	9	12	30	4	8	11	15	37
675 STONE, SLATE, CLAY, PITS	3	4	0	2	9	4	5	0	2	12
681 STRUCTURAL CLAY PRODUCTS MFG	8	16	9	1	34	11	21	11	1	44
682 GLASS MANUFACTURE	4	2	1	2	9	5	3	1	2	12
683 GLASS CONTAINER MFG	2	5	3	1	11	3	7	4	1	14
685 CEMENT MANUFACTURE	7	0	1	5	13	9	0	1	6	17
700 MANUF PROPERTY, <i>IICF</i>	39	90	62	103	294	52	120	75	125	372
708 GENERAL MAINTENANCE	4	2	4	2	12	5	3	5	2	15
709 MANUF PROPERTY <i>NCA</i>	15	20	29	21	85	20	27	35	25	107
710 FOOD INDUSTRY, <i>IICF</i>	2	6	7	4	19	3	8	8	5	24
711 SLAUGHTERING, PREPARATION OF MEAT	17	12	23	13	65	23	16	28	16	82
712 DAIRY PRODUCT MFG	7	18	2	5	32	9	24	2	6	42
713 CANNING, PRESERVING OF FRUIT AND VEGETABLES	3	2	2	0	7	4	3	2	0	9
715 MANUFACTURE OF GRAIN	16	16	16	10	58	21	21	19	12	74
716 BAKERY PRODUCTS	22	30	22	19	93	29	40	27	23	119
717 SUGAR REFINING	8	11	5	5	29	11	15	6	6	37
718 SNACK FOODS MANUFACTURING	7	2	2	3	14	9	3	2	4	18
719 FOOD INDUSTRY <i>NCA</i>	5	5	6	7	23	7	7	7	8	29
723 BREWERY, MALT MFG	4	3	3	4	14	5	4	4	5	18
725 TOBACCO PRODUCTS MFG	3	4	1	2	10	4	5	1	2	13
726 VEGETABLE AND ANIMAL OIL FAT, SOAP MFG	5	0	1	0	6	7	0	1	0	8
730 TEXTILES, <i>IICF</i>	2	3	3	2	10	3	4	4	2	13
732 COTTON SPINNING, WEAVING	11	9	8	5	33	15	12	10	6	42
733 WOOL OR WORSTED SPINNING, WEAVING	4	18	3	1	26	5	24	4	1	34
734 MIXED, BLENDED, OTHER FIBRES	8	6	7	1	22	11	8	8	1	28
735 TEXTILE FINISHING PLANT	11	7	10	9	37	15	9	12	11	47
736 KNITTING MILLS FOR ALL FIBRES	6	7	3	0	16	8	9	4	0	21
739 TEXTILES, <i>NCA</i>	2	2	0	2	6	3	3	0	2	8
741 FOOTWEAR MANUFACTURE	13	5	1	0	19	17	7	1	0	25
742 WEARING APPAREL MFG	18	17	16	9	60	24	23	19	11	77
743 MADE-UP TEXTILE GOOD	0	3	4	1	8	0	4	5	1	10
744 TANNERIES, LEATHER FINISHING	0	2	2	2	6	0	3	2	2	8
747 RUBBER, RUBBER PRODUCTS MFG	28	18	13	7	66	37	24	16	8	86
750 WOOD, PAPER, <i>IICF</i>	0	9	4	1	14	0	12	5	1	18
751 SAWMILL, PLANNING MILL	63	43	69	64	239	84	57	84	78	303
752 WOODEN OR CANE CONTAINERS	5	2	1	2	10	7	3	1	2	13
753 WOOD, CORK PRODUCTS	8	7	10	6	31	11	9	12	7	39
754 FURNITURE, FIXTURE	54	39	39	57	189	72	52	47	69	240
755 PAPER, PULP, PAPERBOARD	22	28	26	7	83	29	37	32	8	107
756 PAPERBOARD PRODUCTS	17	11	9	3	40	23	15	11	4	52
757 NEWSPAPER OR MAGAZINE PUBLISHING	15	9	11	5	40	20	12	13	6	51
758 PRINTING PUBLISHING,	16	33	19	13	81	21	44	23	16	104
759 WOOD, PAPER <i>NCA</i>	5	4	3	0	12	7	5	4	0	16

Appendix 7B (Cont) -Number of fires in various fixed property types from 1 July 1989 to 30 June 1993.

Adjusted years data

	89-90	90-91	91-92	92-93	TOTAL	89-90	90-91	91-92	92-93	TOTAL
760 CHEMICALS, PLASTICS, <i>IICF</i>	2	7	12	1	22	3	9	15	1	28
761 INDUSTRIAL CHEMICAL MFG	8	4	17	4	33	11	5	21	5	41
762 HAZARDOUS CHEMICAL MFG	9	8	5	1	23	12	11	6	1	30
763 PLASTICS MANUFACTURE	5	12	12	4	33	7	16	15	5	42
764 PLASTIC PRODUCTS MFG	15	26	16	27	84	20	35	19	33	107
765 PAINT, VARNISH, LACQUER MFG	13	15	18	8	54	17	20	22	10	69
766 DRUG, COSMETIC, PHARMACEUTICAL MFG	6	6	3	5	20	8	8	4	6	26
767 PETROLEUM REFINERY	10	6	7	3	26	13	8	8	4	33
768 ASPHALT, COAL PRODUCTS	3	3	3	2	11	4	4	4	2	14
769 CHEMICALS, PLASTICS, <i>NCA</i>	5	3	1	2	11	7	4	1	2	14
770 METAL, METAL PRODUCT, <i>IICF</i>	3	5	5	1	14	4	7	6	1	18
771 IRON AND STEEL MANUFACTURE	36	32	27	23	118	48	43	33	28	151
772 NON-FERROUS METAL MFG	38	41	36	33	148	51	55	44	40	189
773 METAL PRODUCT MFG	54	77	53	33	217	72	103	64	40	279
774 MACHINERY MANUFACTURE	10	24	21	7	62	13	32	25	8	79
775 ELECTRICAL EQUIPMENT MFG	13	16	10	8	47	17	21	12	10	60
776 ELECTRICAL APPLIANCE MFG	20	15	5	2	42	27	20	6	2	55
779 METAL, METAL PRODUCT, <i>NCA</i>	12	7	15	1	35	16	9	18	1	45
781 SHIPBUILDING, REPAIR	1	1	2	2	6	1	1	2	2	8
782 BOAT BUILDING, REPAIR	1	3	3	3	10	1	4	4	4	13
783 RAILWAY EQUIPMENT MFG	5	4	1	3	13	7	5	1	4	17
784 MOTOR VEHICLE MFG	38	32	20	9	99	51	43	24	11	128
786 AIRCRAFT AND ROCKET MFG	5	2	3	0	10	7	3	4	0	13
789 VEHICLE MANUFACTURE, <i>NCA</i>	2	2	0	2	6	3	3	0	2	8
790 OTHER MANUFACTURING, <i>IICF</i>	4	3	1	4	12	5	4	1	5	15
791 INSTRUMENT MANUFACTURE	5	1	0	1	7	7	1	0	1	9
792 PHOTOGRAPHIC, OPTICAL GOODS MFG	2	5	1	0	8	3	7	1	0	11
796 LAUNDRY, DRYCLEANING	14	11	7	4	36	19	15	8	5	47
797 PHOTOGRAPHIC FILM PROCESSING	3	4	9	0	16	4	5	11	0	20
799 OTHER MANUFACTURING, <i>NCA</i>	10	1	5	8	24	13	1	6	10	30
800 STORAGE PROPERTY, <i>IICF</i>	73	67	94	118	352	97	89	114	143	444
808 TOOL SHED	125	145	130	107	507	167	193	158	130	647
809 STORAGE PROPERTY <i>NCA</i>	121	99	153	148	521	161	132	185	179	658
810 AGRICULTURAL PRODUCTS STORAGE, <i>IICF</i>	2	1	2	1	6	3	1	2	1	8
811 SEEDS, BEANS, NUTS, STORAGE	12	36	23	16	87	16	48	28	19	111
812 PACKAGED AGRICULTURAL PRODUCTS STORAGE	2	2	9	13	26	3	3	11	16	32
813 LOOSE AGRICULTURAL STORAGE	1	7	4	4	16	1	9	5	5	20
815 BARNS, STABLES	18	19	24	19	80	24	25	29	23	101
817 LIVESTOCK STORAGE	2	3	8	6	19	3	4	10	7	24
818 AGRICULTURAL SUPPLY STORAGE	12	21	9	15	57	16	28	11	18	73
819 AGRICULTURAL PRODUCT STORAGE <i>NCA</i>	0	7	5	8	20	0	9	6	10	25
820 TEXTILE STORAGE, <i>IICF</i>	0	8	4	1	13	0	11	5	1	17
822 BALED WOOL, WORSTED STORAGE	4	2	3	2	11	5	3	4	2	14
826 WEARING APPAREL, FINISHED PRODUCTS STORAGE	12	7	4	7	30	16	9	5	8	39
829 TEXTILE STORAGE <i>NCA</i>	2	3	3	0	8	3	4	4	0	10

Appendix 7B (Cont) -Number of fires in various fixed property types from 1 July 1989 to 30 June 1993.

Adjusted years data

	89-90	90-91	91-92	92-93	TOTAL	89-90	90-91	91-92	92-93	TOTAL
831 PACKAGED FOODSTUFF STORAGE	3	1	5	4	13	4	1	6	5	16
833 LOOSE, BAGGED PROCESS STORAGE	4	2	14	1	21	5	3	17	1	26
835 COLD STORAGE	7	11	3	6	27	9	15	4	7	35
840 PETROLEUM PRODUCTS, <i>IICF</i>	1	0	2	4	7	1	0	2	5	9
841 FLAMMABLE LIQUID TANKS	3	0	2	1	6	4	0	2	1	8
851 TIMBER YARD, BUILDING MATERIALS STORAGE	8	10	18	10	46	11	13	22	12	58
852 WOOD PRODUCTS, FURNITURE STORAGE	11	16	19	5	51	15	21	23	6	65
853 FIBRE PRODUCTS STORAGE	2	2	4	0	8	3	3	5	0	10
855 PAPER, PAPER PRODUCT STORAGE	21	13	17	22	73	28	17	21	27	93
856 TIMBER, PULPWOOD, LOGS STORAGE	0	7	4	2	13	0	9	5	2	17
859 WOOD AND PRODUCTS <i>NCA</i>	0	1	2	4	7	0	1	2	5	9
860 CHEMICALS STORAGE, <i>IICF</i>	2	2	2	2	8	3	3	2	2	10
861 INDUSTRIAL CHEMICAL STORAGE	5	2	1	1	9	7	3	1	1	12
862 HAZARDOUS CHEMICALS STORAGE	3	1	3	0	7	4	1	4	0	9
863 PLASTICS AND PRODUCT STORAGE	5	3	3	4	15	7	4	4	5	19
865 PAINT, VARNISH STORAGE	1	0	1	5	7	1	0	1	6	9
867 RUBBER AND PRODUCTS STORAGE	3	9	0	4	16	4	12	0	5	21
872 METAL PARTS STORAGE	1	6	2	2	11	1	8	2	2	14
873 HARDWARE STORAGE	5	6	6	4	21	7	8	7	5	27
874 MACHINERY STORAGE	9	2	6	6	23	12	3	7	7	29
875 ELECTRICAL APPLIANCE STORAGE	2	7	8	0	17	3	9	10	0	22
877 SCRAP, JUNKYARD	5	1	4	6	16	7	1	5	7	20
879 METAL AND PRODUCTS <i>NCA</i>	2	1	4	2	9	3	1	5	2	11
880 VEHICLE STORAGE, <i>IICF</i>	0	5	5	9	19	0	7	6	11	24
881 RESIDENTIAL PARKING	250	259	213	156	878	333	345	258	189	1126
882 GENERAL VEHICLE PARKING	45	43	49	32	169	60	57	59	39	216
883 BUS, TRUCK, AUTO FLEET STORAGE	7	6	12	10	35	9	8	15	12	44
884 HEAVY MACHINERY, EQUIPMENT STORAGE	9	5	10	8	32	12	7	12	10	40
885 BOAT, SHIP STORAGE	5	3	2	4	14	7	4	2	5	18
886 AIRCRAFT HANGER	1	1	4	1	7	1	1	5	1	9
887 RAILWAY STORAGE	3	3	7	4	17	4	4	8	5	21
888 FIRE STATION	12	14	10	3	39	16	19	12	4	50
889 VEHICLE STORAGE <i>NCA</i>	6	13	16	8	43	8	17	19	10	54
890 GENERAL ITEM STORAGE	3	6	9	4	22	4	8	11	5	28
891 GENERAL WAREHOUSE	34	32	53	36	155	45	43	64	44	196
893 PACKAGED MINERAL PRODUCTS STORAGE	1	3	5	0	9	1	4	6	0	11
894 FREIGHT STORAGE	8	4	9	4	25	11	5	11	5	32
895 COAL, COKE, BRIQUETTE STORAGE	1	5	8	4	18	1	7	10	5	23
898 WHARF, PIER	12	9	8	9	38	16	12	10	11	49
899 GENERAL ITEM STORAGE, <i>NCA</i>	15	37	26	19	97	20	49	32	23	124

Appendix 7B (Cont) -Number of fires in various fixed property types from 1 July 1989 to 30 June 1993.

Adjusted years data

	89-90	90-91	91-92	92-93	TOTAL	89-90	90-91	91-92	92-93	TOTAL
900 SPECIAL PROPERTIES, <i>IICF</i>	2	5	2	6	15	3	7	2	7	19
909 SPECIAL PROPERTIES <i>NCA</i>	8	11	6	8	33	11	15	7	10	42
910 CONSTRUCTION, <i>IICF</i>	3	0	6	9	18	4	0	7	11	22
911 BUILDING UNDER CONSTRUCTION	34	26	17	24	101	45	35	21	29	130
912 BUILDING UNDER DEMOLITION	74	68	51	30	223	99	91	62	36	288
913 CONSTRUCTION, OTHER	3	2	1	1	7	4	3	1	1	9
914 DEMOLITION OTHER THAN BUILDING	3	5	8	4	20	4	7	10	5	25
915 VACANT PROPERTY	148	171	152	107	578	197	228	184	130	739
916 CONTRACTOR'S SHED	14	16	13	14	57	19	21	16	17	73
917 IDLE PROPERTY	57	30	48	30	165	76	40	58	36	211
918 BUILDING UNDER RENOVATION	22	11	19	10	62	29	15	23	12	79
919 CONSTRUCTION <i>NCA</i>	4	5	4	5	18	5	7	5	6	23
920 SPECIAL BUILDING, <i>IICF</i>	3	4	5	3	15	4	5	6	4	19
921 BRIDGE, TRESTLE	21	19	20	17	77	28	25	24	21	98
922 TUNNEL	2	2	1	2	7	3	3	1	2	9
925 SHELTER	16	9	9	13	47	21	12	11	16	60
926 OUTBUILDING, EXCLUDING GARAGE	67	80	93	88	328	89	107	113	107	415
927 OUTDOOR TELEPHONE BOX	21	24	69	83	197	28	32	84	101	244
929 SPECIAL BUILDING <i>NCA</i>	12	6	8	9	35	16	8	10	11	45
930 OUTDOOR PROPERTIES, <i>IICF</i>	1	0	3	2	6	1	0	4	2	7
931 OPEN LAND, FIELD	100	14	15	30	159	133	19	18	36	207
932 DUMP, SANITARY LANDFILL	2	1	2	4	9	3	1	2	5	11
933 PUBLIC MAILBOX	22	31	36	17	106	29	41	44	21	135
935 CAMPSITE WITH UTILITIES	3	4	11	7	25	4	5	13	8	31
936 VACANT LOT	6	4	2	8	20	8	5	2	10	25
939 OUTDOOR PROPERTIES <i>NCA</i>	5	9	14	15	43	7	12	17	18	54
942 WITHIN DESIGNATED PORT ANCHORAGE	0	4	2	0	6	0	5	2	0	8
943 ALONGSIDE QUAY, PIER	4	7	6	1	18	5	9	7	1	23
951 RAILROAD RIGHT OF WAY	12	6	4	1	23	16	8	5	1	30
954 RAILROAD SIGNALLING	2	1	3	0	6	3	1	4	0	8
959 RAILROAD PROPERTY <i>NCA</i>	10	9	6	7	32	13	12	7	8	41
961 LIMITED ACCESS HIGHWAY	14	1	1	1	17	19	1	1	1	22
962 STREET, ROAD, WAY	66	11	11	18	106	88	15	13	22	138
963 ROAD, WAY, STREET	24	6	7	4	41	32	8	8	5	53
964 UNPAVED STREET, ROAD	0	4	2	0	6	0	5	2	0	8
965 UNCOVERED PARKING AREA	5	7	6	5	23	7	9	7	6	29
983 PIPELINE, POWER LINE	4	0	5	0	9	5	0	6	0	11
009 FIXED PROPERTY USE, <i>NCA</i>	27	20	24	18	89	36	27	29	22	114
008 FIXED PROPERTY USE NOT APPLICABLE	0	1	12	4	17	0	1	15	5	21
000 FIXED PROPERTY USE, UNDETERMINED	293	128	244	340	1005	391	171	296	412	1269
<b>TOTAL</b>	<b>14014</b>	<b>15388</b>	<b>17017</b>	<b>13951</b>	<b>60370</b>	<b>18685</b>	<b>20517</b>	<b>20627</b>	<b>16910</b>	<b>76740</b>

Note: *NCA* - Not classified above  
*IICF* - Insufficient information to classify further

The actual data was marked up by .75 for 1989-90 and 1990-91 and 8.25 for 1991-92 and 1992-93 based on the population of urban areas as given by the Australian Bureau of Statistics. The difference being that Queensland began supplying data in 1992.



**APPENDIX 7C -- Type of material ignited first (1989-1993)**

Occupancy		First most common			Second most common			Third most common			Total
Code	Description	No	Code	Description	No	Code	Description	No	Code	Description	No
51	Food, beverage sales	211	31	Fat, grease (food).	112	67	Paper, untreated, uncoated.	104	43	Polyvinyl.	912
16	Eating, drinking places	178	31	Fat, grease (food).	41	00	Undetermined or not reported.	37	67	Paper, untreated, uncoated.	440
58	General item stores	173	67	Paper, untreated, uncoated.	117	43	Polyvinyl.	85	68	Cardboard.	698
54	Specialty shops	46	67	Paper, untreated, uncoated.	44	00	Undetermined or not reported.	38	43	Polyvinyl.	264
92	Special structure	34	67	Paper, untreated, uncoated.	4	43	Polyvinyl.	3	00	Undetermined or not reported.	56
52	Textile, wearing apparel sales	33	43	Polyvinyl.	20	00	Undetermined or not reported.	17	67	Paper, untreated, uncoated.	172
53	Household goods, sales, repairs	32	67	Paper, untreated, uncoated.	28	00	Undetermined or not reported.	21	43	Polyvinyl.	140
57	Motor vehicle or boat sales, service	31	00	Undetermined or not reported.	19	43	Polyvinyl.	18	67	Paper, untreated, uncoated.	145
91	Construction, unoccupied buildings or structures	31	67	Paper, untreated, uncoated.	6	20	Flammable, combustible liquid; insufficient information available to classify further.	5	63 00	Sawn wood. Undetermined or not reported.	72
0	Fixed property use undetermined or not reported	27	54	Grass, leaves, hay, straw.	6	31	Fat, grease (food).	3	00	Undetermined or not reported.	51
59	Offices	23	67	Paper, untreated, uncoated.	12	43	Polyvinyl.	5	69	Wood, paper not otherwise classified.	75
55	Recreation, hobby, or home repair sales, personal services	20	43 67	Polyvinyl. Paper, untreated, uncoated.	13	00	Undetermined or not reported.	10	40	Plastics; insufficient information to classify further.	126
56	Professional supplies, services	19	72	Cotton, rayon, fibre fabric, finished goods.	15	43	Polyvinyl.	12	70	Fabric, textile, fur; insufficient information available to classify further.	107
80	Storage property: unclassified	12	67	Paper, untreated, uncoated.	11	00	Undetermined or not reported.	4	54	Grass, leaves, hay, straw.	46
41	One-family and two-family dwellings	12	31	Fat, grease (food).	6	00	Undetermined or not reported.	3	57	Food, starch.	38
88	Vehicle storage	11	67	Paper, untreated, uncoated.	9	43	Polyvinyl.	3	00	Undetermined or not reported.	41
93	Outdoor properties	11	67	Paper, untreated, uncoated.	3	54 63	Grass, leaves, hay, straw. Sawn wood.				27
50	Commercial properties	9	00	Undetermined or not reported.	3	67	Paper, untreated, uncoated.	2	20 40	Flammable, combustible liquid; insufficient information to classify further. Plastics; insufficient information to classify further.	27
18	Theatres, studios	7	43	Polyvinyl.	4	67 00	Paper, untreated, uncoated. Undetermined or not reported.				31
71	Foods	7	31	Fat, grease (food).	4	43	Polyvinyl.	2	57 63	Food starch. Sawn wood.	27
21	Non-residential schools	7	97	Multiple type of material ignited first.	2	49 69 60	Plastics not otherwise classified. Wood, paper not otherwise classified.				18



Occupancy		First most common			Second most common			Third most common			Total
Code	Description	No	Code	Description	No	Code	Description	No	Code	Description	No
							Wood, paper; insufficient information available to classify further.				
43	Rooming, boarding, lodging houses	5	70	Fabric, textile, fur; insufficient information available to classify further.	4	72	Cotton, rayon, fibre fabric, finished goods.	2	31	Fat, grease (food).	13
96	Road, parking property	4	67	Paper, untreated, uncoated.	3	43	Polyvinyl.	1	23 70	Gasoline/petrol Fabric, textile, fur; insufficient information available to classify further.	9
89	General item storage	4	63	Sawn wood.	2	67 00	Paper, untreated, uncoated. Undetermined or not reported.				10
12	Recreation places, variable use amusement	3	67	Paper, untreated, uncoated.	2	41 00	Polyurethane. Undetermined or not reported.				10
85	Wood, paper and fibre products storage	3	67	Paper, untreated, uncoated.	2	68	Cardboard.	1	54	Grass, leaves, hay, straw.	6
14	Clubs	3	67	Paper, untreated, uncoated.	2	43 72 00	Polyvinyl. Cotton, rayon, fibre fabric, finished goods. Undetermined or not reported.				11
42	Apartments, units, flats	3	00	Undetermined or not reported.	1	27 43 49 63 72	Class D - combustible liquid Polyvinyl. Plastics not otherwise classified. Sawn wood. Cotton, rayon, fibre fabric, finished goods.				8
74	Footwear, wearing apparel, leather, rubber	3	72	Cotton, rayon, fibre fabric, finished goods.							3
75	Wood, furniture, paper, printing	3	00	Undetermined or not reported.	2	43 64 67	Polyvinyl. Wood shavings. Paper, untreated, uncoated.				13
13	Churches, funeral parlours	2	33	Polish.	1	20  55 63 67	Flammable, combustible liquid; insufficient information available to classify further.  Grain, natural fibre (pre-process). Sawn wood. Paper, untreated, uncoated.				6
11	Recreation places, fixed use amusement.	2	43	Polyvinyl.	1	14 31	Liquefied petroleum gas Fat, grease (food).				10

Occupancy		First most common			Second most common			Third most common			Total
Code	Description	No	Code	Description	No	Code	Description	No	Code	Description	No
						49 40 65 68 71 79	Plastics not otherwise classified. Plastics; insufficient information available to classify further. Hardboard, plywood. Cardboard. Man-made fibre fabric, finished goods. Fabric, textile, fur not classified above.				
79	Other manufacturing	2	43 00	Polyvinyl. Undetermined or not reported.	1	21 35 49 73	Class A - flammable liquid. Applied paint, varnish. Plastics not otherwise classified. Wool, wool mixture fibre fabric, finished goods.				8
83	Processed food, tobacco storage	2	68	Cardboard.	1	43 65 00	Polyvinyl. Hardboard, plywood. Undetermined or not reported.				5
87	Metal, metal and electrical product storage	2	49	Plastics not otherwise classified.	1	20 67 00	Flammable, combustible liquid; insufficient information available to classify further. Paper, untreated, uncoated. Undetermined or not reported.				5
22	Residential schools	2	51	Rubber.	1	54 00	Grass, leaves, hay, straw. Undetermined or not reported.				4
49	Other residential occupancies	2	54	Grass, leaves, hay, straw.	1	51 72	Rubber. Cotton, rayon, fibre fabric, finished goods.				4
15	Libraries, museums, court-rooms	2	69	Wood, paper not otherwise classified	1	43	Polyvinyl.				3
46	Dormitories	2	70	Fabric, textile, fur; insufficient information available to classify further.	1	82	Oil cloth.				3
65	Agriculture	2	54	Rope, cord, twine, yarn.	1	23	Gasoline/petrol.				3
98	Equipment operating areas	2	51	Rubber.	1	00	Undetermined or not reported.				3
9	Fixed property use not elsewhere classified	2	43 67 00	Polyvinyl. Paper, untreated, uncoated. Undetermined or not reported.							11
20	Education property: unclassified	2	39 55	Volatile solid, chemical, combustible metal not otherwise classified. Grain, natural fibre (pre-process).							9

Occupancy		First most common			Second most common			Third most common			Total
Code	Description	No	Code	Description	No	Code	Description	No	Code	Description	No
			00	Undetermined or not reported.							
64	Utility, energy distribution systems	1	32	Grease (non-food).							5
			43	Polyvinyl.							
			64	Wood shavings.							
			67	Paper, untreated, uncoated.							
			68	Cardboard.							
32	Care of the young	1	31	Fat, grease, (food).							3
			54	Grass, leaves, hay, straw.							
			68	Cardboard.							
10	Public assembly property: unclassified.	1	43	Polyvinyl.							1
23	Trade, business schools	1	64	Wood shavings.							2
			70	Fabric, textile, fur; insufficient information available to classify further.							
33	Care of the sick, injured	1	24	Class B - flammable liquid.							2
			51	Rubber.							
40	Residential property: unclassified	1	33	Polish.							2
			99	Other type of material not otherwise classified.							
62	Laboratories	1	40	Plastics; insufficient information available to classify further.							2
			54	Grass, leaves, hay, straw.							
63	Communications, defence, document facilities	1	49	Plastics not otherwise classified.							2
			40	Plastics, insufficient information available to classify further.							
82	Textile storage	1	67	Paper, untreated, uncoated.							2
			70	Fabric, textile, fur; insufficient information available to classify further.							
17	Passenger terminals/stations	1	43	Polyvinyl.							1
24	Tertiary institutions, includes colleges of advanced education universities, institutes of technology	1	00	Undetermined or not reported.							1
30	Institutional property: unclassified	1	72	Cotton, rayon, fibre fabric, finished goods.							1
34	Care of the physically restrained	1	70	Fabric, textile, fur; insufficient information available to classify further.							1
35	Care of the physically disabled	1	67	Paper, untreated, uncoated.							1

Occupancy		First most common			Second most common			Third most common			Total
Code	Description	No	Code	Description	No	Code	Description	No	Code	Description	No
44	Hotels, motels, inns lodges	1	00	Undetermined or not reported.							1
48	Holiday apartments, self contained units	1	99	Other type of material not otherwise classified.							1
70	Manufacturing property: unclassified	1	20	Flammable, combustible liquid; insufficient information available to classify further.							1
72	Beverages, tobacco, essential oils	1	76	Human hair.							1
78	Vehicle assembly, manufacture	1	20	Flammable, combustible liquid; insufficient information available to classify further.							1
81	Agricultural products storage	1	69	Wood, paper not otherwise classified.							1
95	Railway property	1	63	Sawn wood.							1
97	Aircraft areas	1	67	Paper, untreated, uncoated.							1
8	Fixed property use not applicable	1	23	Gasoline/petrol.							1
											<b>3628</b>



## APPENDIX 7D

### Glossary of Terms Used in Occupant Capabilities Table

#### a. Alertness

- i. If people are in bed and asleep then their response times to any form or type of cue other than "smell" can be expected to be considerably delayed. Olfactory (smell) cues will not elicit any response when people are asleep.
- ii. People can be involved in an activity or can be impaired in one way or another so that their response times to any type of cue can be expected to be considerably delayed.

#### b. Mobility

If a proportion of the population is expected to be disabled (includes those who are unable to use stairs and ramps because of their mass, those with a heart condition, those who are asthmatic, etc.), then the initial response of these people could be expected to involve additional preparatory work (transferring to wheelchairs, fitting mobility aids). Studies have shown that wheelchair users can take twice as long as those with a greater degree of mobility, to prepare and leave a small bedroom. There are also other forms of disability which should be considered:

- (i) Hearing
- (ii) Vision
- (iii) Mental
- (iv) Other Physical

In addition if people are undergoing medical treatment or institutional care, they may not be capable of responding without assistance. It should be noted that if this factor is found to be prevalent for more than fifteen percent of the population it should be analysed in detail.

#### c. Social Affiliation

- i. Research into the Summerland Fire Disaster showed that in that emergency people tried, as far as possible, to retain contact with their primary social group, the family.
- ii. If parents are separated from their children when the emergency occurs, they are most likely to try to find their children before commencing evacuation.
- iii. People also move towards the familiar (in this case familiar people in an unfamiliar setting) to seek further information and/or assistance. This type of behaviour is known as affiliative behaviour.

#### d. Role

Human Behaviour takes place within existing roles. In an emergency the roles that people normally occupy will influence their behaviour as well as that of others. It follows that if there is a high ratio of well trained staff with a pre-planned and rehearsed set of emergency control procedures to the public there is a greater opportunity to shorten the confused, information gathering phase which is a feature of the response and coping cycles.

#### **e. Position**

The physical position of people in the pre-emergency setting should be taken into account whether they are sitting down, lying, standing or moving around. It takes greater motivation for a person who is lying down to stand up and begin to leave the building, than for a person who is already walking to begin to move to an exit.

#### **f. Commitment**

People are generally action or goal oriented and have reasons for being in a particular place and those reasons will continue to guide or influence their behaviour even when an emergency occurs. People will generally persist with their original intentions such as eating a meal in a restaurant or making a phone call, concluding a purchase in a shop etc. when it is obvious that there is a serious fire in progress.

#### **g. Focal Point**

If the setting has a particular focal point such as a stage in a theatre, the population would normally look to that point for guidance in the response stage of evacuation.

#### **h. Familiarity**

Buildings can comprise very complex environments. It is necessary in Fire Engineering Design to have a detailed knowledge of the likelihood of the building occupants being familiar with the interspatial relationships in the building, particularly in those areas that they do not frequent very often. It should be noted that people will tend to move towards and through those circulation routes with which they are familiar and these may be identical with those used for access and circulation. If these do not correspond with those used in emergencies, then it is essential that the design provides for a system of signage, procedures and the like that will familiarise the occupants with the emergency procedures and exits. This should be an essential component of every set of evacuation procedures and can be achieved via effective evacuation drills.

#### **i. Communications**

The frequency of communication and the content of the messages can affect the sequence, number and duration of activities. If the emergency communication system is either too complex or poorly designed, occupants perceive information as ambiguous, occupants are unorganised/untrained, fire wardens are unfamiliar with procedures and the like then information communicated will slow down or confuse the evacuation process.

#### **j. Decisiveness**

This factor basically describes the ability of people to make decisions under stress and in the presence of others.

#### **k. Visual Access And Signage**

People can find their way around a building if familiar landmarks and exits are visible. Buildings can be designed so that they are legible either as a result of the layout, plan, signage or a combination thereof. People will therefore be able to 'see' where they are going.

#### **l. Complexity**

This describes the maze factor or the Labyrinth effect. It could be linked with 'Visual Access' but has been kept separate because labyrinths even when they are well signposted they may still pose problems with changes in direction for wayfinding.

Measure on a scale from one to five based on the number of turns every twenty metres and the overall distance to be travelled.

#### **m. Population, Occupant Loading - Structure And Crowdedness**

It is necessary to know how many people are in the building at optimum operating capacity (ie. peaks). This is normally expressed as square metres of floor area per person and assumes a uniform distribution across the area under consideration. It is essential for the purpose of estimating evacuation movement times and also the degree of group interaction and safety that the distribution and structure of the occupant groups are known. For many types of buildings the occupant densities are fixed eg. number of seats in an Auditorium, number of bed spaces in a hotel or hospital. Net occupant density (crowdedness) is the measure used to estimate the velocity or flow rate of a group of people using data available from such sources as the book entitled Pedestrian Planning by Dr J.J. Fruin and published by Elevator World in the USA in 1971. This measure is also valuable in analysing the safety aspects of crowding. The general rule is that there are people who can experience stress due to 'confinement' at occupant densities greater than 0.4 sq. m./per person (Refer Table D1.13 of the Building Code of Australia for typical rates).

#### **n. Route Geometry/Safety**

The old 11" tread, 7" riser, stair was once deemed in the USA to 'be the optimum'. This was confirmed by research and statistics, especially by National Institute of Standards and Technology in the publication entitled Stair Safety Guidelines. The slope of stairs is therefore critical as is the slope of ramps. Route geometry including the height of handrails and balustrades must therefore be considered as an integral part of the occupant avoidance subsystem. Refer also to Table 12.13 and AS 1657 re stairways, Platforms and Ladders for further assistance.





## **APPENDIX 9A ASSESSMENT AND VERIFICATION OF COMPUTER MODELS**

### **1. Introduction**

In general the effects of fire will be determined using deterministic models that represent the processes encountered on a compartment fire based on physics and chemistry, or the movement of occupants based on flow speeds and effective widths. Probabilistic models that treat the fire growth as a series of states and assign probabilities to those states are generally only used in a full system risk evaluation.

The deterministic models likely to be used in the assessment of the effects of fire can be broadly classified as:

1. Zone Models
2. Field Models
3. Special purpose models

Zone and Field models are used to determine the extent of smoke and fire spread and the physical properties associated with that spread.

Special purpose models include those programs designed to simulate or determine the time to sprinkler and detector activation (Detact), occupant movement (Evacnett, Exits) and those models designed to simulate air flow within a building (ASCOS).

No matter which type of model is used those who use and are asked to accept the results need to be assured that the models will provide sufficiently accurate results for the specific application planned. To provide this assurance the models being considered should be verified for physical representation and mathematical accuracy. Verification involves checking that the theoretical basis and assumptions used in the model are appropriate, the model contains no serious mathematical errors, and has been shown, by comparison with experimental data, to provide predictions of the course of events in similar fire situations with a known accuracy.

This Appendix deals mainly with zone and field models regarding smoke and fire spread as these will be the programs on whose results the major part of any assessment will be based. Many of the points however, are still valid for many of the special purpose models that may be used.

### **2. Zone Models And Field Models**

A field model is two-dimensional or three-dimensional, divides the space of interest into thousand of cells, or elements, and generally requires a powerful computer.

A zone model is primarily dimensional or two-dimensional, and divides the space of interest into a few zones. Often, a personal computer will suffice for the calculations.

The primary advantage of a field model over a zone model is that the former can provide detailed information on the fluid motions, while the latter cannot (except one-dimensional). The primary advantage of a zone model is its relative simplicity, which permits the inclusion of more phenomena in a given zone model without becoming overwhelmed by complexity. Also, cases may be run far more rapidly and inexpensively.

At this time, zone fire models are more readily transferable from one organisation to another than field models.

Neither field models nor zone fire models can currently make an accurate treatment of certain features of fires associated with the combustion process and with turbulence.

## 2.1 The Inputs, Other Than the Fire Itself

The inputs that generally will be called for to accurately define a fire's growth and spread by a model can include :-

- (a) The geometry of the fire compartment, as well as that of any connecting compartments of interest, must be specified. If a compartment of interest is not a simple box, but is irregular (eg a sloped or concave ceiling; a long corridor with or without bends; an open stairwell), a simplified geometry of equivalent volume may have to be assumed, or a field model rather than a zone model may be required.
- (b) The thermal properties of the bounding surfaces (eg ceilings, walls).
- (c) The area of the fire and height above floor level.
- (d) The location of the burning object or objects. If a burning object is elevated above the floor, this is relevant. A burning object next to a wall or in a corner will burn differently from one in the middle of the room.
- (e) The ventilation conditions (natural, forced, or a combination).

If a model does not call for a particular input it may have either assumed a value for that input (eg. fire area) or may ignore it completely. In general the more inputs a model takes into account and the more accurately those inputs are supplied the more accurate the results are expected to be.

## 2.2 Fire

The fire may be specified in various ways.

- (a) In the simplest case, the fire is specified as starting at a certain time with a certain rate of heat release, and continuing at that rate for a special interval, then stopping. The cross-sectional area of the base of the fire must be specified. It is also necessary to specify the rate of pyrolysis of the combustible and the stoichiometric fuels-air ratio. (The heat release rate, the pyrolysis rate, and the actual heat of combustion are interrelated, so knowledge of any two will define the third).
- (b) The next level of complexity is to specify a fire with a heat release rate varying in a prescribed manner with time.

Certain fires may be accurately specified as constant or varying in a known manner. As one example, the fire may consist of the burning of a fluid leaking at a known rate. As a second example, the fire may be ventilation-controlled, and a knowledge of the rate of oxygen entry into the compartment will determine the rate of heat release. As a third example, the burning rate of the ignited object may be measured in the open, and it is assumed that it would burn at the same rate in the fire compartment. (eg. Firecall) This may be somewhat valid for a burning object such as a 'crib' of alternatively stacked sticks, since the burning sticks in the interior of the crib cannot 'see' the outside radiative environment.

Many burning objects do interact strongly with the surrounding radiative environment. Furthermore, the arrangement of combustibles is often such that the fire can spread. Some models assume a spread rate, as a function of radiative feedback. Thus, the type of model which requires the fire to be fully specified in advance and does not adjust the specified fire for compartment conditions is very limited in applicability. (Such a model could be used to make a conservative estimate of the fire consequence, by inputting the maximum conceivable heat release rate).

- (c) More realism is added to the model if the input includes an instruction that the prescribed burning rate is reduced according to some formula as the percentage of oxygen decreases in the atmosphere surrounding the fire plume and if the yield of combustion species can be altered with oxygen concentration. This requires the computer program to keep track of the dilution of the incoming air by mixing with the fire products, and of the descent of the smoke layer (eg CFAST).
- (d) The radiative feedback of energy from the compartment to the burning surface generally will have a major effect on the burning rate, and on the spread rate as spread is occurring. It is important in causing spontaneous ignition of noncontiguous combustibles.

The sources of this radiation are the hot smoke layer, the ceiling and upper walls, and the flame itself. The sensitivity of the burning of a sample to incident radiation can be estimated by a bench-scale experiment, for a simple combustible, and may be inputted into the model, but it is much more difficult for the model to calculate accurately the radiative flux impinging on the surface under radiative fire conditions.

The following difficulties exist in estimating the effect of radiation:-

- (i) The radiation intensity is proportional to  $T^4$ , so small errors in calculation of the temperature of the hot smoke or of the ceiling cause much larger errors in the radiant heat flux. (When re-radiation is taken into account, the net radiant flux may vary as about  $T^4$ ).
- (ii) The temperature of the hot upper layer is sensitive to the amount of excess air entrained into the fire plume, and also to the rate of heat loss to the ceiling. Neither of these can be calculated with great accuracy, especially in a zone model. The accuracy obtained using a field model is dependent on the turbulence model used.
- (iii) The smoke not only emits radiation; it also absorbs and scatters radiation. In general, cooler smoke will be below the hot smoke, influencing radiation from above.
- (iv) The 'view factors' between the radiative sources and the targets requires elaborate mathematical representation for accurate treatment.
- (v) The radiative properties of the smoke, the flame, the ceiling, and the targets must be accurately known.
- (vi) Simple zone models do not take into account the fact that the region directly over the fire is much hotter than more remote upper regions, especially in large compartments. Field models can take this into account, but have to deal with the complexity that each of the thousands of elements in the field model can in principle exchange energy radiatively with all the other elements, instead of simply the immediate adjacent elements.

For these reasons, an accurate treatment of the radiative augmentation of burning rate or spread rate is hard to achieve, and is not incorporated into many models.

- (e) The foregoing treatments of the burning rate usually assume that full-scale experimental results are available for burning rate of the combustible objects at least in the open. An alternative approach would be to use bench-scale data of relevant burning characteristics of the combustibles, using small samples and then 'scale up' the data using various empirical and theoretical methods (eg Delichatsios and Saito).

The model chosen for a particular application should be matched to that application if accurate and meaningful results are to be obtained. For example in large warehouse oxygen depletion may not be a problem and hence a model that takes into account oxygen depletion may not be required. On the other hand for residential sized enclosures oxygen depletion may occur and will be important to the fire size and species yields.

### **2.3 The Model Outputs**

After the model has been provided with inputs as discussed above, a computation takes place, yielding various physical outputs versus time: temperatures and velocities at various locations; concentrations of smoke, oxygen, toxic species, corrosive species at various locations; and heat fluxes impinging on objects of interests. The model might then proceed to calculate consequences of these physical variables: for example, actuation times of detectors or sprinklers; feasibility of escape; feasibility of manual fire-fighting; thermal damage or corrosion of smoke damage to structural elements or critical equipment items; effectiveness of automatic suppression systems; etc. (Of course, in order to obtain outputs such as these, the locations and characteristics of the items of interest must be included in the inputs).

### **2.4 Additional Uncertainties in Models**

Uncertainties associated with burning rates (especially when the combustible is a composite) and with radiative flux calculations have already been mentioned. Some other uncertain elements in fire models may be listed:

- (a) carbon monoxide produced by incomplete combustion,
- (b) entrainment rate into the plume;
- (c) mixing between hot and cold layers;
- (d) heat loss to the ceiling as a function of distance from fire axis;
- (e) breakage of windows during a fire;
- (f) smoke movement under conditions other than box-like geometries;
- (g) flow through ceilings vents;
- (h) ignitibility conditions of fuel-rich fire products encountering fresh air;
- (i) effects of fire products on humans.

## **3. Validation Of Models**

A model may not yield results in complete accord with actual fire behaviour for any of five reasons:

1. idealisations and simplifications on which the model is based deviate significantly from reality;
2. input parameters supplied to the model are inaccurate;
3. 'default' values of co-efficients used internally in the model (because the user was unable to supply better values of these co-efficients) are incorrect;
4. the computation process itself yields a wrong result, perhaps because the time steps or the mesh size used to approximate differential equations with finite-difference equations is not fine enough, or because of mathematical singularities or instabilities encountered;
5. the experimental measurements themselves are incorrect or non-repeatable.

Validation of a model involves comparison of model predictions with realistic fire tests. Very often, this involves 'fine tuning' the model by adjusting uncertain values of input co-efficients. Once the 'tuned' model is brought into agreement with the measurements, the question remains as to the validity of the model when applied to a different set of conditions.

If the model can be shown to agree with a series of fire tests, with a wide range of conditions and with a minimum of 'tuning', then one's confidence in the validity would be substantial. Even so, it would be risky to extrapolate to conditions drastically different from those that have been tested.

#### **4. Documentation Regarding The Use And Application Of Computer Models**

Sufficient documentation of calculation models, including computer software, should be reviewed to assess the adequacy of the scientific and technical basis of the models, and the accuracy of computational procedures for the application to which the model is to be used. Also, adequate documentation will help prevent the unintentional misuse of fire models. Reports on any assessment and verification of a specific model should become part of the documentation that is available if requested by the user of the model or the person asked to accept the model results.

Documentation accompanying any computer model should include technical documentation and a users' manual. The technical document often in the form of a scientific or engineering journal publication is needed to assess the scientific basis of the model. A users manual should enable users to understand the model application and methodology, reproduce the computer operating environment and the results of sample problems included in the manual, modify data inputs, and run the program for specified ranges of parameters and extreme cases. The manual should be concise enough to serve as a reference document for the preparation of input data and the interpretation of results. Installation maintenance and programming documentation may be included in the user's manual or be provided separately. There should be sufficient information to install the program on a computer, and to modify it or extend it to meet specific needs.

The version of the model, the name of the organisation responsible for the models development, and any variation from the default parameters that the user has made should be fully documented and accompany the presentation of the results in the assessment report.

##### **4.1 Technical Documents**

Technical documentation that should accompany any model, be understood by the model user, and available upon request by those asked to accept the results should:-

- . Define the fire problem modelled, or function performed by the model
- . Include any feasibility studies and justification statements
- . Describe the theoretical basis of the phenomena and physical laws on which the model is based
- . Present the governing equations
- . Identify the major assumptions and limits of applicability
- . Describe the mathematical techniques, procedures and computational algorithms employed and provide references for them
  
- . Discuss the precision of the results obtained by important algorithms, and any dependence on particular computer capabilities
- . List any auxiliary programs or external data files required
- . Provide information on the source, contents, and use of data libraries
- . Provide the results of any efforts to evaluate the predictive capabilities of the model
- . Provide references to reviews, analytical tests, comparison tests, experimental validation, and code checking already performed.

## 4.2 User's Manual

In order for the model to be used effectively it is recommended that the users manual should:-

- . Include self contained description of the program
- . Describe the basic processing tasks performed, and methods and procedures employed (a flow chart can be useful)
- . Identify the programming languages and software operating systems and versions in use
- . Describe the source of input information and any special input techniques
- . Describe the handling of consecutive cases
- . Provide the default values or the general conventions governing them
- . List any property values defined within the program
- . Describe the contents and organisation of any external data files
- . Describe the program output and any graphics display and plot routines
- . Provide sample data files with associated outputs to allow the user to verify the correct operation of the program

## 5. Sensitivity Analysis

A sensitivity analysis of the results produced from any model should be performed and reported as part of the assessment documentation.

A sensitivity analysis of a model is a study of how changes in model parameters affect the results generated by the model. Model predictions may be sensitive to uncertainties in input data, to the level of rigour employed in modelling the relevant physics and chemistry, and to use of inadequate numerical treatments. A well designed and executed sensitivity analysis serves to:

- . identify the dominant variables in the models,
- . define the acceptable range of values for each input variable, and
- . demonstrate the sensitivity of output variables to variations in input data
- . inform and caution any potential users about the degrees and level of care to be taken in selecting input and running the model
- . provide insights as to which parameters should be monitored in large scale fire experiments.

Conducting a sensitivity analysis is not a simple task. A practical problem to be faced when designing a sensitivity analysis experiment, is that the number of model runs required will rapidly increase with the number of input parameters and number of independent variables considered.

A distinction must be made between parameters which are internal and those which are external to the model. The former provide an in-sight on how well the physics and the mathematics utilised in the model reflect real fire behaviour and should be subject to verification by the model developers. The latter are those parameters which the user can manipulate as inputs. External parameters that a sensitivity analysis can be conducted around can be portioned as follows:

- Geometrical: fire enclosure's basic dimensions, openings, vents, and connecting adjacent spaces.
- fire scenario: slow fire, fast fire, very fast fire, derived from knowledge of the heats of combustion fuel loss rate, and fuel distribution.

- thermophysical: the thermophysical properties of the enclosure's boundaries can influence the growth and development of fire, hence properties such as conductivity, specific heat, density and emissivity of floors, walls, and ceilings are necessary input.

## References

1. Friedman R., 'An International Survey of Computer Models for Fire and Smoke', *Journal of Fire Protection Engineering* 4, 81-93 1992.
2. ISD document ISO/TC92/SC4/WG/N82, 'Assessment and Verification of Fire Calculation Models', NIST, 1995.





## APPENDIX 9B - Field Models for Fire Safety Engineering

### 1 Field models

#### 1.1 Field models, general

Field modelling is the term used for the application of computational fluid dynamics (CFD) to the simulation of fire and smoke flow. In contrast with zone models, field models make little or no a-priori simplifications about the heat and mass transfer processes that occur during a fire. The models solve a set of equations that represent the fundamental equations of conservation of mass, momentum, energy and chemical species subject to the boundary and initial conditions that represent the initial fire scenario under consideration. This equation set is then solved numerically using a computer.

The technique has been most successfully employed to date to simulate the movement of the gaseous products of combustion (smoke) throughout enclosures. The method enables solution of a range of problems that zone models cannot tackle. For example, the influence of pre-fire temperature gradients throughout the air in an enclosure can be included as can the influence of external wind pressures on the movement of smoke within a building or other enclosure. Although in principle the method can be used to study the whole range of fire processes including fire growth and spread, such techniques are still in research phase and are not yet developed to the point where they can be used to practical fire-safety engineering studies. For this reason, the discussion given here on the field modelling of fire will be restricted to its application to the transport of gaseous products of combustion (smoke) throughout enclosures.

#### 1.2 Theoretical background

##### (a) General equations

Fires are complex thermo fluid processes involving in general a chemically reacting medium.

The basic equation set on which the simulation of the transport of smoke and fire gases throughout an enclosure is based can be summarised as follows:

$$\frac{\partial(\rho\Phi)}{\partial t} + \frac{\partial\rho\mu_i\Phi}{\partial\chi_i} - \frac{\partial}{\partial\chi_i}(\Gamma_\Phi \frac{\partial\Phi}{\partial\chi_i}) = S_\Phi \quad (1)$$

*Time rate of change + convection + diffusion = source/sink,*

Where  $\Phi$  is a generic variable which may represent, for instance, the three Cartesian velocity components  $\mu_i$ , the enthalpy  $h$ , or the mass fraction of a particular species  $m_j$ . The mass continuity equation is represented by the case  $\Phi = 1$ .  $S_\Phi$  is a source term appropriate to  $\Phi$  which incorporates, for example, the effects of chemical production and radiative heat loss.

A Cartesian grid is not essential but is generally used for simplicity. All dependent variables in the equation set above are time-averaged quantities. The diffusion term incorporates the effects of both turbulent and molecular diffusion through the exchange coefficient  $\Gamma_\Phi$ . In most field modelling studies of fire it is assumed that the Reynolds stresses and scalar fluxes, which involve the correlations for

fluctuating properties, can be modelled by use of gradient transport hypothesis, which for scalars is

$$\langle \rho \rangle \langle \mu_i \Phi' \rangle = -\Gamma_\Phi \frac{\partial \langle \Phi \rangle}{\partial \chi_i}$$

To determine the local value of  $\Gamma_\Phi$ , in all practical applications of CFD two further transport equations are solved for  $k$ , the turbulent kinetic energy and  $\varepsilon$ , its rate of dissipation. The effects of buoyancy on extra turbulence production (in rising plumes) and inhibition (in stratified layers) require special attention.

#### **(b) Computational grid**

The process of numerical solution of the fundamental equations employed by CFD proceeds by dividing (“discretizing”) the volume of interest into a number (generally a very large number!) of elementary volumes called control volumes which are located in a three-dimensional grid.

Methods are available that enable volumes within envelopes of relatively arbitrary shape to be discretized. The method is very flexible in its application in that three-dimensional time-dependent problems can be solved throughout volumes (enclosures) of unrestricted size and shape.

#### **(c) Solution process**

The equation set (1) is discretized and solved iteratively at the control volumes. This is achieved using an iterative process exploiting an algorithm known as SIMPLE or one of its variants SIMPLER, SIMPLEL.

Solution of the equations along with appropriate initial and boundary conditions to specify the (energy) heat and momentum loss to the enveloping enclosure which can incorporate the effects of the influence of vents and pre-fire conditions gives a representation of the major quantitative features of how gases move throughout the enclosure for any fire size. However, the discrete nature of the solution has certain implications. Physical features of the “true” solutions at length or time scale less than those associated with the numerical mesh size or time step used cannot be captured.

#### **(d) Representing the fire**

Given its present state of development fire science is unable to provide fully robust and comprehensive methods for predicting fire growth and so the fire source term cannot be fully modelled within a fire-modelling treatment. This limitation is overcome by specifying within the model a fire source term with a predetermined rate of fuel mass release rate or energy release rate against time (the design fire). This is often represented as a volumetric source term in the control volume located where the fire would be.

The method can incorporate combustion and thermal radiation; the incorporation of a combustion model is necessary if it is required to incorporate extended releases of heat over volumes (within say the fire plume) as determined by local mixing conditions.

#### **(e) Thermal radiation**

Two quite distinct difficulties need to be addressed for the realistic modelling of radiant heat transfer. The first concerns “geometrical” problems associated, in particular, with the exchange of radiant energy between remote emitters and receivers, be they solid surfaces such as compartment walls or particulate/gas

phase mixtures such as smoke and flames. The second difficulty concerns the calculation of local absorption/emissive properties. The relative contributions from broadband soot and spectral gaseous emissions will vary substantially between flame and smoke products. In addition, as with transport processes and combustion chemistry, the effect of turbulent fluctuations in temperature and gas composition may influence radiant heat transfer. In smoke movement assessment this latter influence is generally ignored. Although more sophisticated treatments are required for the treatment of flame spread, many smoke-movement analyses assume a grey gas of mixed absorptivity and calculate radiant heat transfer only in the six Cartesian coordinate directions based on time-mean predictions of local gas temperature.

### **1.3 Input data**

Field models require detailed specification of the enclosure geometry and any significant obstructions such as stored goods, which may influence smoke flow. The enclosure geometry forms the basis on which the computational grid is generated. The following items will generally need to be specified:

- Thermal characteristics of the boundary including any obstruction.
- Location of inlets and outlets.
- Appropriate boundary conditions at inlet and outlet.
- Location and dimensions of “fire” or energy source.
- Time history of the energy release from the “fire”.
- Location and time-history of fuel flow if combustion is modelled.
- Smoke concentration at the source.
- Toxic species concentration at the source.
- Ambient temperature and pressure.
- Exhaust inlets and outlets.
- Turbulence at source (optional).
- Location and temperature of hot surfaces.

A fixed pressure boundary condition is often assumed at outlets in the modelling of fire phenomena.

### **1.4 Output data.**

### **1.5 Acceptance of results**

### **1.6 Limitations of field models**

Field models used in the prediction of development of untenable conditions must have the following features :-

- Appropriate turbulence model incorporating buoyancy source items
- Energy release of the fire (as a function of time if appropriate)
- Sufficient resolution particularly around the fire plume to properly resolve entrainment
- Calculation of smoke and/or toxic species concentration in the field
- Radiative losses if the temperature of the hot layer is significantly above that of the surroundings.



## APPENDIX 10A - Calculating Radiant Heat Flux on Remote Combustible Materials

### Scope

The ignition of combustible materials remote<sup>1</sup> from the fire due to the imposed radiation heat flux on the material surface is a major means of fire spread. Methods of calculating the imposed radiation heat flux on a combustible material remotely located from the fire source are presented in this Appendix. These calculations may be used to determine the likelihood of fire spread for combustible materials:

- in the fire enclosure;
- in the enclosure or space which adjoins the fire enclosure through openings;
- on linings of the exterior wall surface of the opening;
- on the external facade of the building or on the adjacent building; and
- in the enclosure on the next level or in the adjacent building.

The results can then be used to determine the time at which fire spread occurs. If ignition of the remote combustible is to be prevented, then the results can be used to determine:

- the required separation distance to achieve acceptable radiation levels; and/or
- the suitability of the exposed materials to the predicted radiation levels.

### Overview

All combustible materials exposed to heat has a potential to ignite when the imposed heat exceeds the limiting conditions for ignition (see Section 8.6.1 and Table 8.1). Radiation is the main heat transfer process for igniting a combustible material located away from the fire.

For materials in the fire enclosure, the fire is initially the main source of heat. As the fire develops and generates a hot layer beneath the ceiling of the enclosure, radiation from the hot upper layer can significantly contribute to the imposed radiant heat flux on the exposed material. It is usual to assume that during flashover, the radiation from the hot layer is sufficiently high to ignite all the exposed combustible materials in the enclosure.

For fires in large open spaces or in enclosures with high ceilings, the temperature in the upper layer may not develop sufficiently to significantly contribute to the imposed radiation on the combustible material.

When considering combustibles outside the fire enclosure, the main source of radiation is from the openings of the enclosure. Here, instead of the fire, the area of the openings acts as an effective 'radiating panel' to which the combustibles are exposed. The temperature of the hot gases may be taken as the temperature of the radiating panel. If the exterior wall which contains the opening is lined with combustible materials, then the area of combustible lining may be considered to be alight and contribute to the area of the radiating panel.

During the fully-developed stage of the fire, the gases escaping through the openings of the fire enclosure will contain unburnt volatiles. This occurs even if the fire is not ventilation controlled because of the limited burning efficiency of natural fires. Obviously, the content of unburnt volatiles is much higher in ventilation controlled fires. The burning of the volatiles at the opening generate an external fire plume which further contributes to the size of the radiating panel.

When determining the potential for ignition of an exposed combustible material away from the heat source, the intensity of radiation imposed on the material a distance away from the heat source has to be calculated. This is achieved by the use of a configuration factor,

---

<sup>1</sup> Located at a sufficient distance away such that piloted ignition does not occur.

which relates the amount of heat transferred from a finite area of heat source to an infinitesimal point at the receiver.

The results from these calculations can be used to determine if the combustible material will contribute to the spread of fire. Alternatively, if ignition of the material is to be prevented then appropriate decisions on suitable separation distances or to the choice of using less ignitable or noncombustible materials can be made.

## **Calculating the Radiation Level on a Remote Combustible Material**

### ***Introduction***

The potential for ignition of a combustible material in the fire enclosure remotely located from the fire source is calculated by considering the sources of heat which radiates onto the exposed material. The calculations are applicable to conditions in the enclosure prior to the occurrence of flashover or in enclosures with larger open spaces where the conditions do not lead to the occurrence of flashover.

During the early stages of fire growth, before the development of a hot upper layer, the main source of heat is from the luminous flames. The calculation of the radiant heat from the flames are considered in the section entitled 'Direct Exposure Within Fire Enclosure'. As the temperature of the upper layer increases, its contribution to the imposed radiant heat on the material must also be considered. The calculation details are provided in the following section entitled 'Radiation from Hot Layer'. This section is also applicable for calculating the imposed radiant heat on combustibles in an adjacent enclosure which has collected sufficient hot gases beneath its ceiling through openings to the fire enclosure. The contribution from the ceiling surface can usually be ignored due to radiation blocking by the smoke layer. Radiation from the wall surfaces can also be ignored unless their surface temperatures are unusually high.

Finally, the calculation of radiation from openings in the fire enclosure to areas outside the enclosure is given in the section entitled 'Exposure Through Openings of Enclosure'. These are applicable to combustibles in the adjacent enclosures connected to the fire enclosure and to combustibles in the building exterior or in adjacent buildings.

Note that the relationships introduced here are adopted from Heskestad's Chapter on Fire Plumes in the SFPE Handbook. They are only indicative of the simpler relationships that are available for the determination of the parameters required for calculating the radiation level from a fire. The fire safety engineer should assess the suitability of these relationships to the particular situation being studied. For example, the design of spandrels will require a more complex analysis than is presented here.

### ***Direct Exposure Within Fire Enclosure***

#### ***Fire Plume***

The heat release rate defined in Chapter 8 comprises two components; the convective component  $Q_c$  and the radiative component  $Q_r$ . The radiative component can be as high as 30 to 40 per cent of the total heat release rate, depending upon the luminosity of the flames (30 per cent is typical although 20 per cent is a good estimate for flames of low luminosity, e.g. methyl alcohol).

#### ***Flame Height***

The visible flames above a fire source comprise the combustion reaction zone and an inert zone where combustion is essentially complete. Typically the luminosity of the lower part of the flaming region is fairly steady whilst the upper part is intermittent. The intermittency at height  $z$  above the fire source is defined as the fraction of time that at least part of the flame lies above  $z$ . The flame height  $L$  (m) is usually taken as a mean value distance

above the fire source where the intermittency of the flame is 0.5. Heskestad has proposed the following correlation based on experimental data on horizontal surface fires:

$$L = -1.02D + 0.235 Q^{2/5} \quad Q > 40 D \quad (1)$$

where  $D$  (m) is the effective diameter of the fire source (such that  $\pi D^2/4$  = area of fire source) and  $Q$  (kW) is the total heat release rate. The condition  $Q > 40 D$  is imposed to ensure that negative flame heights are avoided.

#### Area of Fire Source

The area of fire source  $A_s$  (m<sup>2</sup>) can be determined based on the size of the combustible item or group of items on fire. If this information is unavailable then  $A_f$  can be estimated from the effective fire load density  $q_{ki}$  (MJ/m<sup>2</sup>) for fires which has not or does not flash over.

Hence  $A_s = \frac{q_t}{q_{ki}}$

where

$q_t$  = cumulative amount of combustible consumed by the fire (MJ) at time  $t$  secs  
 $= \int_0^t Q dt$   
 where  $Q$  is the heat release rate (MW)

The effective diameter of the fire source at time  $t$  can then be determined as follows:

$$D(t) = \sqrt{4A_s/\pi}$$

#### Flame Temperature

The rise in the centreline flame temperature  $\Delta T_0$  can be estimated using the expression

$$\Delta T_0 = 9.1 [T_\infty / (g c_p^2 \rho_\infty^2)]^{1/3} Q_c^{2/3} (z - z_0)^{-5/3} \quad \dagger 900K$$

where

- $T_\infty$  is the ambient temperature (K)
- $\rho_\infty$  is the ambient density (kg/m<sup>3</sup>)
- $c_p$  is the specific heat of air (kJ/kg·K)
- $g$  is the acceleration of gravity (m/s<sup>2</sup>)
- $z_0$  is the height or virtual origin above top of combustible (m)
- and  $Q_c$  is the convective heat release rate (kW)

However, this relationship is only accurate up to a rise of 500K and should not exceed 900K. Between 500K and 900K the relationship will conservatively overestimate  $\Delta T_0$ . For the purpose of calculating radiation levels, the flame temperature can be averaged over various heights along the plume (e.g. at the midpoint and the upper and lower quarterpoints).

#### Radiation from the flame

Knowing the area of the fire source and the average centreline flame temperature ( $T_f = T_\infty + (\Delta T_0)_{av}$ ), the radiation of the fire onto a point on a combustible remote from the fire can then be calculated using the equation (ignoring the material surface temperature) as follows:

$$q_r = \phi \sigma \varepsilon T_f^4$$

The most commonly used configuration factor is for a rectangular shape surface to a parallel small element on a perpendicular to one corner (Tien *et al* , SFPE handbook).



$$X = a/c, \quad Y = b/c$$

$$\phi = \frac{1}{2\pi} \left\{ \frac{X}{\sqrt{1+X^2}} \tan^{-1} \left[ \frac{Y}{\sqrt{1+X^2}} \right] + \frac{Y}{\sqrt{1+Y^2}} \tan^{-1} \left[ \frac{X}{\sqrt{1+Y^2}} \right] \right\}$$

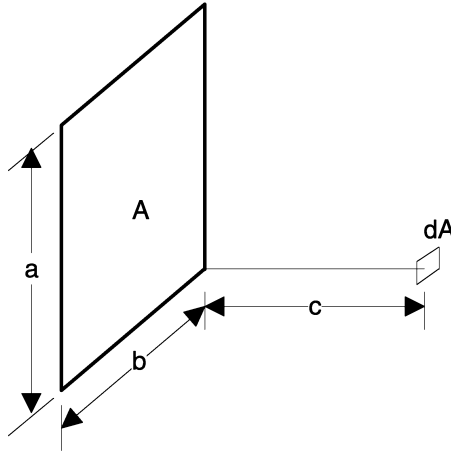

**Figure 1 Receiver dA due to Panel A on perpendicular from corner of Panel A**

Configuration factors are additive (and subtractive). The effective configuration factor  $\phi_e$  for the four panels on element dA along the normal of the intersecting lines as shown in figure 2 is

$$\phi_e = \phi_A + \phi_B + \phi_C + \phi_D$$

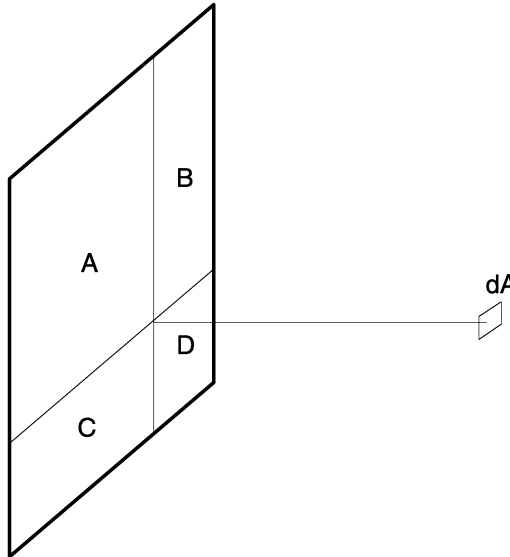

**Figure 2 Additive feature of configuration factors**

The flame emissivity may be conservatively taken as 1.0 as being representative of thick luminous flames.

Alternatively, a less rigorous approach may be adopted by assuming that half of the radiative component of the heat flux is exposed to the target material, i.e.

$$q_r = \frac{\phi Q_r}{2(DL)}$$

### ***Radiation from Hot Layer***

The radiation from the hot upper layer can be similarly calculated if the temperature of the smoky layer  $T_s$  and the depth of the layer  $d_s$  are known, using

$$q_r = \phi \sigma \epsilon_s T_s^4$$

where  $\epsilon_s$  = emissivity of the smoke layer  
 $= (1 - e^{-\kappa S})$

$\kappa$  is the effective absorption coefficient of the smoke and  $S$  is the physical pathlength (i.e. depth of smoke layer). For solid wood fuels,  $\kappa$  is approximately 0.8 (refer Table 1-4.3 of SFPE handbook for other values).

### ***Exposure Through Openings of Enclosure***

#### ***General***

Radiation from openings are particularly relevant when considering the spread of flames outside of the fire enclosure. When the openings are located in external walls, the required separation of the building to prevent fire spread to an adjacent building can be calculated. The temperature of the upper gas layer in the fire enclosure may be used as the radiating temperature with the area of the opening as the size of the radiating panel. These, together with the appropriate configuration factor can then be used to determine the imposed radiant heat flux on the remote combustible material.

#### ***External Burning***

Because the gases in the fire enclosure are likely to contain unburnt volatiles, the gases which escape through openings in walls tend to develop a fire plume. However, the shape of the external plume is influenced by a number of factors such as the opening size and wind conditions, apart from concentration of unburnt volatiles. Because of the fast reaction time of the volatiles when mixed with outside air, the height of the external plume does not normally extend more than a few metres (one to two metres is typical) from the centre of the outflow of gases from the opening. However, the following situations may extend the height of the plume:

- depletion of oxygen due to a fire on the lower floor;
- excessively high concentration of unburnt combustible volatiles in the escaping gases;
- inadequate mixing in situations where the opening is large resulting in a large plume with a relatively low surface area to volume ratio; and
- forced or through ventilation in the fire enclosure, expelling the gases out at a high rate.

Unless these conditions can be expected, adding one to two metres to the height of the opening, depending upon the severity and ventilation conditions of the fire, will normally provide reasonable results. Otherwise, the rate of heat release of the plume out of the openings must be determined to enable a more precise prediction of the flame height.

#### ***Combustible Lining***

The presence of combustible lining can be accounted for by extending the area of the opening to include the area of a combustible lining.

### Multiple Openings

Multiple openings can be considered by the appropriate use of configuration factors. For example, the effective configuration factor for the two openings shown in Figure 3 below is calculated as follows:

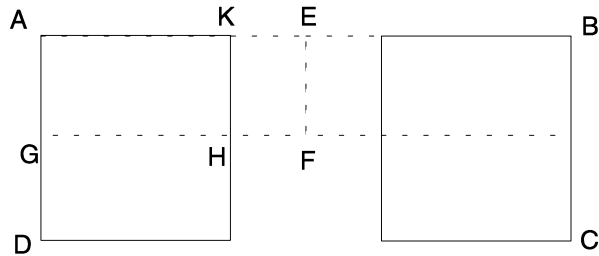

**Figure 3. Calculation of configuration factors for multiple openings**

1. The effective centroid of the openings is point F in Figure 3. This is where the heat flux is the greatest, assuming that the fire has spread to both the spaces which are behind the openings.
2. The overall configuration factor for ABCD comprises four quadrants of AKHG. The effective configuration factor for quadrant AKHG is

$$\phi_{AKHG} = \phi_{AEFG} - \phi_{KEFH}$$

Hence

$$\begin{aligned}\phi_{ABCD} &= 4 \times \phi_{AKHG} \\ &= 4 \times (\phi_{AEFG} - \phi_{KEFH})\end{aligned}$$

Alternatively, a simpler approach may be adopted by simply multiplying the configuration factor for  $\phi_{AEFG}$  by the proportion of the radiating area, i.e.  $A_{AKHG} / A_{AEFG}$ . Hence

$$\phi_{ABCD} = 4\phi_{AEFG} \times A_{AKHG} / A_{AEFG}$$

## APPENDIX 12A

### Detailed Egress Design Information

The purpose of this appendix is as follows:

- (a) Outline what the design of each component of the Occupant Avoidance Subsystem should encompass.
- (b) Outline what the documentation of each component should define together with the verification and maintenance criteria.

(a) and (b) will be outlined for the:

- (i) Response
- (ii) Coping; and
- (iii) Evacuation/Coping

components of the occupant avoidance subsystem.

#### 12A.1 Response Component

The design of the Occupant Response Component should ensure:

- (a) the purpose of the design is achieved
- (b) Performance is achieved in practice

The documentation of the design should define the following:

- (a) initiation of response translated into response procedures to enforce the type of information conveyed by the fire alarm and the needs and capabilities of the occupants. Also includes the design of the information to be conveyed by the fire alarm.
- (b) Quality Standards (AS 3902.5)
- (c) Performance parameters (the results of the analysis carried out in the design and assessment days) must be translated into performance criteria when they vary from those in AS 3745.
- (d) Model used: A full report or statement should be prepared as part of the design process and all limitations/advantage listed. All suggested compensation built into the design of the component should be fully noted.
- (e) Reliability of the subsystem - probabilities: this can be achieved via either trialing or an analysis to establish weakness in the system using a risk reduction approach. Vulnerable points should be strengthened as required where an overall increased performance in safety and time is required.
- (f) Verification: A procedure should be established to confirm the operational aspects of the system. This may be via physical test of each sub/sub component or via peer review.
- (g) Maintenance criteria and level must be appropriate to the needs of the occupants and the reliability of the subsystem. Generally adopt the AS 1851 series for the appropriate component eg. Emergency Warning and Intercommunication system.

General design parameters depend on the content of Codes and the Performance Criteria established viz.

- (i) Fire Alarms - Bells AS1603
- (ii) Evacuation Response AS 3745

## **12A.2 Coping/Evacuation Escape Component**

The design of these components should ensure:

- (a) the purpose of the design is achieved,
- (b) performance is achieved in practice.

It should be noted that item(b) is extremely difficult to achieve in some occupancies eg. apartment buildings. Evacuation planning and procedures may have to be replaced by equivalent improvements in the standard and format of information conveyed by the fire alarm, simplification of the exit system or even the development an overall design that will defend the occupants in place until such time as Fire Brigade Rescue can be effected.

The documentation for the design should define the following in varying levels of detail suitable for use at the following stages of design.

- (a) Sketch Plan (Concept)
- (b) Building/Development Consent Plans (Design Development)

The sub components so referred to are:

- (1) Exit access routes and enclosure design
- (2) Exit entry design
- (3) Integration of access control requirements
- (4) Safe haven and exit capacity
- (5) Exit location and distribution criteria from the analysis
- (6) Exit system - corridors, ramps, stairs and stair geometry, handrails, balustrades etc.
- (7) Emergency communication and information systems plus plans and procedures (caters for coping)
- (8) Sign posting including emergency/passive lighting
- (9) Training as part of all items to ensure familiarly, commitment and focus
- (10) Building Emergency Control Organisation, Plan and Procedures.

The performance of the system is that it must satisfy the needs of the occupants so as to ensure that they are not exposed to untenable conditions at any stage of their evacuation.

The sub components themselves once defined should be designed in accordance with the criteria or Codes set down in Table 12A.1.

The subcomponents listed in items (1) to (10) and also in Table 12A.1 must be designed, installed, tested, maintained and operated in accordance with the intent of the original design. The original design shall be fully documented in base performance terms in a schedule as appropriate. The overall sub system should be operated and tested at a minimum of two times per annum.

**Table 12A.1 Design Standards for Escape Systems**

<b>COMPONENT</b>	<b>DESIGN STANDARD</b>
1. Exit access radius or location	(a) As per evacuation analysis, or (b) Travel distances as default values as specified in Part D1 of the BCA or NFPA 101.
2. Wayfinding Constraints	Egress or evacuation routes in formally planned buildings or portions thereof shall be designed in accordance with the following standards :  (a) As per criteria in evacuation analysis (b) As a minimum, no occupant should be required to negotiate more than two turns every 20m. in an exit system without adequate signage .
3. Carrying capacity of exits and exit access routes (include. flow rates and minimum widths)	(a) As per evacuation analysis (b) default values as specified in Part D1 of the BCA or NFPA 101.
4. Means of Access between zones and enclosures	(a) As per evacuation analysis (b) default values and requirements as specified in Part D1 and D2 of the BCA and NFPA 101
5. Exit Access Route design	(a) As per evacuation analysis (b) Default values and requirements of Parts D1 and D2 of the BCA, C2/ASI and D1/ASI of the NRBC, or NFPA 101 re minimum widths, heights, obstructions etc. for hallways, corridors, passages, lobbies, balconies, ramps and the like. (c) in addition to (b) as a minimum, where travel through these components involves more than two changes in direction the component shall be signposted at low level with an appropriate passive illumination system. (d) the components shall also be designed with the appropriate carrying capacity to achieve the flow rates calculated in the evacuation analysis.
6. Exit system design (doors, passages, balconies, ramps, stairs, and the like including a combination thereof )	(As per item 5)

(Table 12A.1 Design Standards for Escape Systems continued)

<p>7. Stair system configuration and safety</p>	<p>(a) As per evacuation analysis                  (b) All stairs shall have two handrails as a minimum                  (c) Stair nosings shall be marked with a contrasting colour                  (d) Minimum handrail height of 900mm                  (e) Default requirements and values for stairs in Parts D1 and D2 of the BCA, NFPA101, D1/AS1 of the NZBC as a minimum                  (f) Door hardware and operation shall not be less than that specified in Part D2 of the BCA or NFPA 101.</p>
<p>8. Visual Access</p>	<p>Where the access routes and the exit systems are unfamiliar to the occupants and where they are not clearly visible from the enclosure of fire origin , even when signposting has been used, emergency evacuation training programs shall be put in place as part of the evacuation plan and procedures (default to AS3745)</p>
<p>9. Safe Havens</p>	<p>(a) As per evacuation analysis                  (b) As a minimum the safe havens shall be designed in accordance with NFPA 101                  (c) Each safe haven shall be provided with its own exit</p>
<p>10. Hazards and Obstructions</p>	<p>Location of and linkage with services, plantrooms and storage areas and the like shall be :</p> <p>(a) As per Part D1 and D2 of the BCA or NFPA 101.</p>
<p>11. Staffing, organisation and training</p>	<p>(a) As per evacuation analysis : or                  (b) All occupancies where the occupants are unfamiliar with evacuation system or require assistance the staff shall be fully trained , organised and managed to assist in evacuation and building emergency control activities. Their effectiveness and efficiency shall be measured and tested at least once per annum over the design life of the building .</p>
<p>12. Emergency Plan and Procedures</p>	<p>(a) As per the evacuation analysis ; or                  (b) As a minimum in accordance with AS3745-1990                  (c) Designed by an evacuation specialist to achieve the criteria set down in (a)</p>
<p>13. Emergency Warning and Intercommunication system</p>	<p>(a) As per response analysis                  (b) AS2220 and AS3745-1990</p>

(Table 12A.1 Design Standards for Escape Systems continued)

<p>14. Signposting</p> <p>(i) Exit Signs</p>   <p>(ii) Emergency Lighting</p>   <p>(iii) Passive Illumination systems</p>	<p>(a) As per evacuation analysis ; or (b) AS 2293 including location at every change in direction where the exit entry is unclear, exit entry point and final access point of the exit system to an open space or safe haven.</p> <p>(a) Locate in accordance with item 8. (b) All in accordance with AS2293 except for sole occupancy units in residential building</p> <p>Passive illumination systems shall be those devices that can be attached to or incorporated into the building fabric and that are capable of providing illumination where the level of illumination provided by natural or artificial lighting systems in emergencies are less than 1 lux . The passive illumination system shall be capable of recharging itself from the natural or artificial lighting system over a minimum period of three hours. The passive system shall operate at the required level for a minimum of 1hr.</p>
<p>15. Egress for persons with disabilities</p>	<p>(a) Barrier free access shall be provided to all exits where assistance is not available from those occupants without disabilities (b) Where assistance is provided, the escape system shall be designed in accordance with NFPA101</p>



# INDEX

**A**

ACCEPTANCE CRITERIA	3.1, 3.3, 3.5 - 3.7, 3.10, 3.13, 3.14, 4.1, 4.2, 4.4 - 4.9, 4.13, 4.14, 6.3, 6.13, 6.15, 6.30, 8.26, 9.17
ACCESS	2.2, 5.3, 5.4, 5.6, 5.10, 5.16 - 5.18, 7.3, 7.15, 10.2, 12.2, 12.16, 12.17, 13.2, 13.4, 13.7
ACTIVATION OF SUPPRESSION	8.14, 11.4
AIR HANDLING SYSTEMS	9.3, 9.5, 9.13, 9.14, 10.2
ALARM / ALARM SYSTEMS	1.1, 2.3, 3.8, 5.9, 5.11, 5.13 - 5.16, 5.18, 6.13, 6.18, 6.24, 7.3, 9.17, 11.2, 11.3, 11.4, 11.6, 11.10, 11.14, 11.16, 11.18, 11.22, 11.23, 12.1, 12.2, 12.8 - 12.10, 12.12, 12.13, 13.4, 13.5, 13.9
ALTERNATIVE EXITS	5.4
APARTMENT	11.25
ARRIVAL TIME	5.17, 8.27, 13.1, 13.2, 13.3, 13.4, 13.5, 13.6
ASPHYXIANTS	4.7
ASPIRATING DETECTOR	11.3, 11.18
ATRIUM	5.6, 10.2
AUTOMATIC SPRINKLERS	5.13
AUTOMATIC SUPPRESSION	11.4, 11.6, 11.9, 11.10, 11.19
AVAILABLE SAFE EGRESS TIME (ASET)	2.1, 4.6, 6.15, 6.17, 6.19, 6.25
AVOIDANCE TIME	12.16, 12.18

**B**

BARRIER	2.1, 4.5, 5.4, 5.6 - 5.10, 6.7, 6.8, 6.12, 6.13, 6.17, 6.19, 6.20, 6.29, 7.1, 8.1, 8.26, 8.27, 9.3, 9.15, 9.17, 9.18, 10.2, 10.3, 10.4, 10.6, 10.9, 10.13
BUILDING CHARACTERISATION	7.2
BUILDING CHARACTERISTICS	9.8, 12.7
BUILDING CODE OF AUSTRALIA / BCA	1.1, 3.2, 3.8, 3.9, 3.14, 4.1, 4.2, 4.3, 4.4, 4.5, 4.9, 4.12, 5.10, 9.17, 12.8, 12.16
- Objectives	4.3
BUILDING LOCATION AND ACCESS	13.4
BUILDING SURVEYOR	1.1, 3.2, 3.5, 3.9, 3.14, 4.3, 4.13

**C**

CALORIFIC VALUE	2.1, 2.2, 7.4, 7.6
CALORIMETER	8.6, 8.18, 8.19, 8.20
CAPACITY	2.3, 5.16, 6.11, 6.17, 6.29, 8.27, 9.16, 10.3, 10.7, 10.11, 12.16
CARBON DIOXIDE (CO <sub>2</sub> )	4.7
CARBON MONOXIDE (CO)	1.1, 4.7, 4.8, 7.17, 8.4, 8.14, 8.20, 8.21, 9.2, 9.8, 9.9, 9.10, 9.11
CHANGE OF USE	3.3, 3.15
CHAR / CHARRING	5.7, 8.10
CHARACTERISATION - of contents	7.3
- of fire safety systems	7.2
CLASSIFICATION	5.16, 6.17, 7.6
CLEAR WIDTH	2.1
COMBUSTIBLE	2.2, 2.3, 4.1, 4.10, 4.14, 5.5 - 5.8, 5.10, 6.17, 6.19, 6.29, 7.3, 7.4, 7.6, 8.3 - 8.7, 8.9, 8.13, 8.15, 8.18 - 8.21, 8.24, 10.3 - 10.6, 10.9, 10.12, 10.13,
COMBUSTION	1.2, 2.1 - 2.3, 4.6, 4.7, 4.14, 5.7, 5.11, 6.6, 8.3, 8.4, 8.7, 8.14, 8.20 - 8.25, 9.1, 9.2, 9.4, 9.9, 10.10, 11.13, 11.22, 11.25, 12.1, 12.2, 12.9, 12.17
COMMISSION / COMMISSIONING	3.3, 3.14, 5.16, 9.18, 11.21, 11.22, 11.23
COMMON MODE FAILURES	5.9, 6.29
COMPARTMENT / COMPARTMENTATION	2.1 - 2.3, 3.10, 5.4, 5.15, 5.17, 6.3, 6.11, 6.21, 6.29, 7.3, 7.4, 7.7, 7.10, 7.11, 8.7, 8.8, 8.10, 8.24, 8.25, 9.3, 9.5, 9.14, 10.9, 11.13, 11.22, 11.23, 12.18, 13.4, 13.8
CONCEPT DESIGN / CONCEPTUAL DESIGN	1.1, 3.1, 3.3 - 3.7, 3.9, 3.10, 3.13, 3.14, 3.15, 4.1, 4.11 - 4.14, 5.3, 5.16, 6.2, 6.3, 6.5, 6.6, 6.8, 6.10, 6.12, 6.13, 6.15, 6.16, 6.18, 6.19, 6.21, 6.28,
CONCEPT PLAN	5.16
CONCRETE	10.8, 10.11, 10.14
CONDUCTION	8.4, 8.5, 10.7
CONDUCTIVITY	7.2, 8.5, 10.7, 10.8, 10.10

CONSTRUCTION	1.1, 1.2, 3.3, 3.14, 4.10, 4.12 - 4.14, 5.2, 5.9, 5.10, 5.12, 5.13, 6.3, 6.19, 6.23, 7.2, 7.4, 7.6, 7.17, 9.15, 10.2, 10.8, 10.14
CONTENTS (BUILDING)	3.14, 4.3, 4.8, 4.10, 5.5, 5.6, 5.7, 5.11, 6.28, 7.1, 7.3, 7.4, 7.6, 8.21, 8.24, 9.16
CONVECTION	8.5, 10.8, 10.9
COPING	5.5, 5.14, 5.16, 6.18, 7.12 - 7.14, 12.1, 12.4, 12.6, 12.8, 12.14 - 12.16, 12.19
CORRIDOR	2.1, 4.7, 5.4, 11.12
<b>D</b>	
DECAY	2.2, 5.6, 6.9, 8.1, 8.2, 8.10, 8.12, 8.26, 8.27, 10.6
DEEMED TO SATISFY	1.1, 3.2, 3.8
DESIGN - Approval	3.1, 3.14
- Documentation	3.14, 4.1, 4.13, 4.14
- Evaluation	6.6
- Guidance	3.7, 4.13, 5.1
- Objectives	1.1, 3.2, 3.5, 4.1, 4.2, 4.14, 5.14, 10.3
- Process	1.2, 3.1, 3.2, 3.4, 3.7, 3.9, 4.1, 4.14, 5.5, 9.17, 11.3, 12.1, 12.4, 12.6, 13.1
- Strategies	4.11, 5.2, 5.14
DESIGN FIRE	7.9, 10.13
DETECTION	1.1, 2.1, 3.6, 3.8, 3.9, 4.10, 5.1, 5.3, 5.4, 5.9, 5.11 - 5.13, 5.15, 5.17, 6.2, 6.3, 6.7, 6.16, 6.20, 6.24, 6.25, 6.29, 7.3, 7.12, 8.2, 9.5, 9.8, 9.17, 11.1, 11.2, 11.4 - 11.7, 11.9 - 11.11, 11.13, 11.16, 11.18, 11.19, 11.22, 11.23, 12.2, 13.4, 13.9
DETECTORS	3.8, 5.4, 5.11, 5.12, 5.13, 7.11, 7.12, 9.2, 9.4, 9.6, 9.8, 9.17, 11.1 - 11.4, 11.6, 11.11, 11.12, 11.14 - 11.18, 11.25, 13.9
DETERMINISTIC	2.1, 6.10
DISABLED	12.21
DISPATCH TIME	13.2, 13.5, 13.6
DOOR	5.4, 5.7, 5.9, 6.7, 6.11, 6.12, 6.29, 8.24, 9.5, 9.12, 9.15, 9.18, 10.11, 11.4, 12.20

DUCT	5.10, 7.2, 7.8, 9.15, 9.16, 9.17, 10.2
DWELLING	7.6, 7.9 - 7.11, 11.25
<b>E</b>	
EARLY SUPPRESSION FAST RESPONSE	5.13, 9.6, 11.4, 11.21
SPRINKLER (ESFR)	
EFFECTIVE FIRE LOAD DENSITY	7.3
EFFECTIVE HEIGHT	8.25
EFFECTIVE WIDTH	12.16, 12.18
EGRESS	2.1, 3.9, 3.10, 4.6, 5.3, 5.9, 5.14 - 5.16, 6.10, 6.17, 10.3, 11.22, 12.6, 12.17, 12.21
ELECTRIC POWER	5.9
ENCLOSURE GEOMETRY	8.14, 9.6, 10.4
ENVIRONMENTAL EFFECTS	7.11, 9.8
ENVIRONMENTAL/ COMMUNITY PROTECTION	4.4
ESCAPE TIME	6.15 - 6.19, 6.25, 13.4
EVACUATION	2.2, 2.3, 3.3, 3.8, 3.13, 3.15, 4.6, 4.10, 4.14, 5.3, 5.14 - 5.16, 6.9, 6.15, 6.16, 6.19, 7.1, 7.12 - 7.16, 9.18, 11.1, 11.4, 11.10, 12.1 - 12.4, 12.6 - 12.8, 12.14 - 12.22, 13.1, 13.2, 13.4, 13.5, 13.7
EVACUATION TIME	6.15, 11.4, 11.10, 12.8, 13.4
EVALUATION / EVALUATION CRITERIA	1.1, 3.1, 3.4, 3.6 - 3.10, 3.13 - 3.15, 4.1, 4.2, 4.4 - 4.6, 4.9 - 4.12, 4.14, 6.1 - 6.6, 6.9 - 6.19, 6.21 - 6.23, 6.25, 6.28, 6.30, 7.4, 8.12, 8.23, 9.9, 10.10, 11.10, 11.26, 12.7, 12.9, 12.16, 12.19, 12.21, 13.1, 13.9
EVENT TREE	3.13, 6.5, 6.8, 6.23, 6.24
EXIT	2.2, 2.3, 4.8, 5.3, 5.4, 5.14 - 5.16, 6.16, 6.18, 6.25, 7.2, 7.15, 12.2, 12.4, 12.6, 12.16 - 12.18, 12.21, 12.22
EXPECTED RISK TO LIFE (ERL)	3.13, 3.14, 4.5, 4.9, 6.20, 6.21, 6.27
EXPOSURE	4.7, 4.8, 6.16, 6.17, 10.3, 10.10
EXTERNAL SPREAD	5.10
EXTERNAL TEMPERATURE	7.11
EXTINGUISHER	5.12
EXTINGUISHMENT	5.9, 5.12, 5.17, 6.8, 6.13, 11.4, 11.6, 11.10, 11.21, 11.22, 11.24, 13.3, 13.5, 13.6, 13.9

**F**

FACTORY	7.9, 7.10
FAST FIRE	8.19
FAST RESPONSE SPRINKLER	5.13
FIRE ALARM	5.9, 5.14, 5.16, 7.3, 11.2, 11.10, 12.1, 12.2, 12.8, 12.12, 13.4
FIRE BRIGADE	1.2, 3.7, 3.14, 4.4, 5.1, 5.9, 5.15, 5.17, 5.18, 6.1, 6.2, 6.12, 6.20, 7.3, 9.17, 10.3, 11.1, 11.4, 11.10, 12.2, 13.1 - 13.9
- Fire Brigade Objective	4.4
FIRE COMPARTMENT	10.9
FIRE DOOR	6.29
FIRE DYNAMICS	1.2, 8.28, 9.19, 10.13
FIRE ENGINEERING DESIGN BRIEF (FEDB)	3.1, 3.4, 3.5, 3.7 - 3.10, 3.13, 3.14, 4.1, 4.2, 4.4, 4.6, 4.10 - 4.14, 6.3, 6.6, 6.7, 6.11, 6.13, 6.15 - 6.17, 6.27, 6.28 - 6.30, 7.1, 7.2, 8.2, 8.4, 9.4, 9.6, 9.8, 10.3, 10.11, 11.6, 12.7, 12.16, 13.4 - 13.6, 13.8
FIRE FIGHTING	5.14, 5.17, 7.2, 7.14, 8.14, 8.27, 11.1, 11.5, 11.24, 11.25, 13.2, 13.5, 13.7
FIRE GROWTH PARAMETER	8.18, 8.19
FIRE LOAD	2.1, 2.2, 2.3, 4.5, 6.10, 6.18, 6.29, 7.3, 7.4, 7.6, 8.19, 10.9, 10.11, 13.8
- Fire Load Density	2.1, 6.10, 6.18, 7.3, 7.4, 10.11, 13.8
- Fire Load Protected	2.1, 2.3, 7.6
FIRE MANAGEMENT	5.1, 5.7
FIRE MODELS - ASCOS	9.14
- ASKFRS	9.10, 9.19
- CFAST	9.11
- Computational Fluid Dynamics (CFD)	9.5, 9.9, 9.13
- DETACT	11.12, 11.13
- Engineering Model	6.10, 6.11
- EVACNET	12.8, 12.18, 12.22
- EVACSIM	12.18
- Field Model	8.24, 9.9, 9.10, 9.13, 9.14, 9.16, 10.10
- FIRECALC	9.10, 9.19
- FPETOOL	9.10, 9.19, 11.12, 11.13

- WAYOUT	12.8, 12.18, 12.22
- Zone Model	9.12, 9.13, 9.16, 10.10, 11.16
FIRE PROTECTION ENGINEER	3.1
FIRE RESISTANCE	2.3, 5.9, 6.10, 7.2, 7.6, 10.3, 10.13, 13.8
FIRE RESISTING	2.1, 7.3, 7.6
FIRE SAFETY MANUAL	2.2
FIRE SAFETY SYSTEM / FIRE SAFETY SUB-SYSTEM	1.1, 3.1, 3.3, 3.4, 3.5, 3.7, 3.8, 3.13 - 3.15, 4.3, 4.5, 4.6, 4.14, 5.2, 5.3, 5.15, 6.1 - 6.3, 6.5 - 6.7, 6.9, 6.10, 6.12, 6.15, 6.19, 6.20, 6.21, 6.25, 6.29, 6.30, 7.1, 7.2, 7.7, 11.26, 12.6, 12.8
FIRE SCENARIO	2.2, 3.1, 3.5, 3.8, 3.10 - 3.13, 4.1, 4.4, 4.9 - 4.13, 5.2, 5.4, 5.16, 6.1 - 6.16, 6.19, 6.20, 6.22 - 6.28, 7.1, 7.8 - 7.10, 8.2, 8.3, 8.6, 8.12, 8.17, 8.18, 12.6, 13.6
FIRE SEVERITY.	10.9, 10.11
FIRE SPREAD	3.6, 4.3, 4.5, 4.9, 4.11, 5.3, 5.4, 5.8 - 5.10, 5.17, 6.2, 6.6, 6.7, 6.17, 6.20, 6.29, 7.3, 8.5, 9.16, 9.17, 10.1 - 10.7, 10.12, 10.13, 10.14, 11.20
- Factors Influencing	10.2
- Means Of	10.2
- Mechanisms	10.1
FIRE STARTS	6.12, 7.6, 7.7, 7.10, 12.3
FIRE SUPPRESSION	1.1, 5.11, 5.12, 7.1, 7.12, 8.1, 8.10, 8.11, 8.14, 8.28, 11.1, 11.4, 11.6, 11.8, 11.9, 11.26, 13.4, 13.5
FLAME DETECTORS	5.12, 11.2, 11.3, 11.18
FLAME HEIGHT	8.15, 8.28
FLAME SPREAD	4.1, 5.7, 5.10, 7.11, 10.12
FLASHOVER	2.2, 5.5, 5.7, 5.17, 6.7, 6.8, 6.9, 6.12, 7.10, 7.11, 8.7, 8.8, 8.15, 8.24, 8.28, 9.18, 9.19, 10.2, 10.4, 10.13, 11.18, 12.11, 13.2, 13.7, 13.9
- Flashover Time	8.15
FLOW TIME	6.18
FRACTIONAL EFFECTIVE DOSE (FED)	4.7
FULLY DEVELOPED FIRE	5.7, 5.10, 8.8, 8.25, 10.8, 10.13

**G**

GASEOUS SUPPRESSION	5.13, 11.4
GROWTH PARAMETER	8.18, 8.19
GROWTH TIME	8.6, 8.19

**H**

HALON	11.23, 11.26
HAZARD / HAZARD IDENTIFICATION	2.2, 2.3, 3.5, 4.1, 4.10, 4.12, 4.13, 5.1, 5.5, 6.30, 9.19, 11.4, 11.20, 11.26
HEAT DETECTORS	5.11, 5.12, 7.11, 7.12, 9.4, 9.6, 11.2, 11.3, 11.11, 11.12, 11.14
HEAT RELEASE RATE	4.11, 6.17, 7.9, 8.20, 9.2, 9.8, 9.13, 10.4, 10.13, 11.2, 11.4 - 11.6, 11.9 - 11.12, 11.15, 11.19 - 11.21, 13.2, 13.4 - 13.8
- Modification Of	13.8
- Modified	11.11, 13.6
HEAT TRANSFER	8.5, 8.7, 8.20, 10.6 - 10.8, 10.12, 10.14, 11.2, 11.9, 11.11
HOSE REEL	6.2, 8.12
HOT LAYER	4.5, 4.6, 4.7, 5.7, 5.8, 8.7, 8.14, 8.15, 8.24, 8.25, 9.2 - 9.6, 9.9, 9.11, 9.12, 11.16
HUMIDITY	4.7, 7.12
HYDRANT	5.18, 7.2, 13.5

**I**

IGNITION	2.1, 2.2, 4.1, 4.9, 4.10, 5.5, 5.7, 5.8, 5.10, 6.6, 6.7, 6.9, 6.17, 6.26, 7.11, 8.1 - 8.5, 8.12, 8.15 - 8.18, 8.20, 8.24, 8.28, 10.2, 10.4 - 10.7, 10.9, 10.12, 10.13
INCAPACITATION	4.7, 4.8, 6.16, 6.18
INERT GAS	11.4, 11.21, 11.22
INITIATION	3.6, 4.10, 5.1, 5.5, 6.1, 6.2, 6.6, 6.7, 6.23, 6.25, 8.1, 8.2, 10.4, 10.6, 10.12, 11.5, 11.9, 11.10, 12.3
INSULATION	10.8, 10.11



INTEGRITY	7.6, 9.18, 10.2, 10.3, 10.11
INTERNAL AIR MOVEMENT	7.12, 9.8
INTERNAL TEMPERATURE	7.11
INTERVENTIONS	8.11, 8.27
IRRITANT	4.7, 4.8

**L**

LEVEL 1 (SEE SUB SYSTEM EQUIVALENCE EVALUATION)	3.8, 3.13, 4.4, 4.5, 6.1 - 6.3, 6.9, 6.12 - 6.14, 6.16, 6.30, 7.2, 8.27, 12.6
LEVEL 2 (SEE SYSTEM PERFORMANCE EVALUATION)	3.8 - 3.10, 3.13, 4.4 - 4.6, 4.8, 4.10, 4.11, 4.13, 6.1 - 6.3, 6.5, 6.15, 6.16, 8.12, 8.27, 12.6
LEVEL 3 (SEE SYSTEM RISK EVALUATION)	3.9, 3.10, 3.13, 4.4, 4.5, 4.9, 4.10, 4.12, 4.13, 6.1 - 6.3, 6.5, 6.11, 6.12, 6.19, 6.22, 6.23, 6.25, 7.2, 7.11, 8.12, 8.26, 10.6, 12.6
LIABILITY	3.15
LIFE SAFETY CRITERIA	4.6, 4.7, 4.9
LIGHT	5.13, 9.4, 11.3, 11.17, 11.18, 11.20
LOADBEARING	10.8, 10.11
LOSS CONTROL CRITERIA	4.8, 4.9
LOSS CONTROL OBJECTIVES	4.3

**M**

MAINTENANCE	1.2, 3.3, 3.14, 3.15, 4.10, 4.14, 5.5, 5.12, 5.15, 6.3, 6.11, 6.28, 6.29, 9.18, 11.23
MANAGEMENT	1.1, 1.2, 2.2, 3.3, 3.6, 3.9, 3.14, 3.15, 4.2 - 4.4, 4.8, 4.10 - 4.14, 5.1, 5.4, 5.6, 5.7, 5.15, 5.16, 6.2, 6.7, 6.12, 6.13, 6.18, 6.25, 8.3, 9.1 - 9.3, 9.8, 9.11, 9.16 - 9.19, 10.1, 11.1, 11.4, 11.10, 11.25, 12.7, 12.8, 12.20, 13.7
MANAGER	1.1, 2.2
MANUAL SUPPRESSION	5.5, 5.12, 5.17, 11.23
MASONRY	10.11
MASS LOSS	8.16, 8.17, 8.26, 8.27

MATERIALS	1.1, 1.2, 2.1, 4.4, 4.9, 4.10, 4.14, 5.5, 5.7, 5.8, 5.9, 6.17, 6.19, 7.2 - 7.4, 7.5, 7.6, 7.10, 8.3, 8.4, 8.9, 8.12, 8.15, 8.16, 8.18 - 8.20, 8.22, 8.28, 9.19, 10.2, 10.7 - 10.9, 10.11, 10.14, 11.13
MEANS OF ESCAPE	1.1, 13.1
MEDIUM FIRE	8.19
METHODOLOGY	1.1, 1.2, 2.1, 3.1, 3.7, 3.14, 4.4, 4.9, 6.2, 6.3, 6.15, 6.19, 6.21, 11.26, 13.7 - 13.9
METHODS OF EVALUATION	4.12, 6.1, 6.2, 6.3
METHODS OF EVALUATION	
<b>N</b>	
NEW OPENINGS	8.14
NOTIFICATION TIME	13.4
<b>O</b>	
OCCUPANCY	1.1, 3.3, 4.1, 4.7, 4.10, 4.13, 5.3, 5.5, 5.13, 6.16, 6.29, 7.2, 7.3, 7.4, 7.6 - 7.10, 7.12, 7.13, 7.15, 7.16, 8.13, 8.19, 10.14, 11.20, 11.24, 11.25, 12.3, 12.7, 12.8, 12.15, 12.17, 13.4
- Characteristics	8.13
OCCUPANT - Avoidance	3.6, 5.1, 5.3, 5.14 - 5.16, 6.2, 7.12, 7.15, 7.16, 12.1 - 12.9, 12.14, 12.17, 12.18
- Avoidance Time	12.7
- Capability	5.15, 5.16, 7.12 - 7.14, 12.1, 12.8, 12.14, 12.17
- Capacity	2.3
- Characterisation	5.16, 7.1, 7.12
- Characteristics	6.2, 12.6, 12.7
- Coping	7.13, 7.14, 12.14, 12.15
- Density	7.15, 7.16
- Profile	7.1, 7.14 - 7.16, 12.8, 12.11, 12.12, 12.14 - 12.17
- Response	6.7, 7.13, 7.14, 12.9, 12.11, 12.12, 12.13
- Suppression By	8.14

OFFICE	5.3, 7.9, 7.10, 10.11 - 10.14, 11.18, 11.25, 12.18, 12.22
OPENINGS / PENETRATIONS	5.7, 5.8, 5.9, 5.10, 8.27, 9.3, 9.7, 9.8, 9.15, 9.17, 9.18, 10.1 - 10.4, 10.6, 10.9, 10.11 - 10.13
OPTICAL DENSITY	4.7, 4.8, 8.21, 9.2, 9.4, 9.5, 9.9, 9.12, 11.3, 11.9, 11.16
- Equivalent Optical Density	4.8
OXYGEN	2.1, 5.6, 5.9, 8.3, 8.14, 8.15, 8.19, 8.24, 11.21

**P**

PHASED EVACUATION	2.3, 6.19, 13.1
PORTABLE EXTINGUISHERS	5.12, 5.13, 6.2
PRE-FLASHOVER	8.2 - 8.4, 8.17
PRESCRIPTIVE	1.1, 3.2, 3.8, 3.9, 3.14, 4.5, 4.12, 4.13, 5.1, 6.5, 6.13, 6.15
PRESSURISATION SYSTEM	5.7, 7.3, 9.18
PROBABILISTIC	3.9, 3.10, 4.4, 4.5, 4.9, 4.10, 4.12, 4.13, 6.4, 6.10, 6.12, 6.19 - 6.21, 6.29, 7.11
PROBABILITY	2.3, 3.10, 4.9, 4.11, 5.5, 5.11 - 5.13, 5.17, 6.5, 6.6, 6.12, 6.20, 6.21, 6.25 - 6.28, 7.7, 7.8, 7.11, 9.2, 9.16, 9.18, 10.6, 10.13, 11.1, 11.6, 11.18, 11.23, 12.1, 12.7 - 12.11, 13.8, 13.9
PROPERTY PROTECTION	3.2, 4.3, 5.2, 5.12, 13.1
PYROLYSIS	5.7, 8.4, 8.6, 8.8, 8.15, 8.23, 8.26, 9.1

**Q**

QUANTIFIED ANALYSIS	3.1, 3.5, 4.12
---------------------	----------------

**R**

RADIANT HEAT FLUX	5.8, 10.2, 12.2
RADIATION	4.3, 4.5 - 4.8, 5.8 - 5.10, 5.12, 6.17, 7.8, 8.5, 8.6, 8.16, 8.19, 8.24, 8.25, 8.28, 10.3, 10.8 - 10.10, 10.12, 10.14, 11.3

REDUNDANT / REDUNDANCY	4.11, 4.13, 5.1, 5.2
REFURBISH	3.5, 3.7, 4.2
RELIABILITY	3.10, 4.10, 5.7 - 5.9, 5.12, 5.13, 5.16, 6.2, 6.11, 6.12, 6.21, 6.28, 6.29, 9.16, 9.18, 11.26
RESCUE	4.3, 5.12, 5.15, 5.17, 6.8, 12.2, 12.4, 13.2, 13.4, 13.5, 13.7
RESIDENTIAL	4.7, 5.3, 5.11, 5.13, 6.6, 7.7, 7.9, 7.10, 12.7, 12.15
RESPONSE CAPABILITY	7.12 - 7.14, 12.6, 12.9, 12.11, 12.19
RESPONSE TIME INDEX (RTI)	5.13, 11.4, 11.11, 11.13, 11.14, 11.16
RETARDANT	5.6, 5.7
RISK	2.3, 3.9, 3.10, 3.13, 3.14, 4.1 - 4.5, 4.8, 4.9, 4.10, 4.12, 5.2, 5.10, 5.17, 6.1, 6.2, 6.5, 6.6, 6.18 - 6.23, 6.25, 6.26, 6.27, 6.28, 6.30, 7.3, 9.6, 11.26, 13.9

**S**

SAFE PLACE	2.3, 12.1, 12.3, 12.6
SCHOOL	11.25, 12.22
SECURITY	5.4, 5.11, 5.14 - 5.16, 12.8
SELF-CLOSING	9.6
SENSITIVITY ANALYSIS	4.14, 6.10, 6.11, 6.12, 6.21, 7.11
SHOPPING CENTRE	3.10, 5.6
SIGNS	12.9, 12.20
SLOW FIRE	6.6, 8.9, 8.19, 8.24
SMOKE - Alarms	5.11
- Barriers	5.6
- Characteristics	9.4, 11.3
- Detectors	5.11, 5.12, 9.2, 9.4, 9.17, 11.3, 11.15 - 11.18, 13.9
- Development	3.6, 3.9, 6.2, 6.7, 9.1, 9.2, 9.4, 9.10
- Exhaust	9.3
- Management	1.1, 1.2, 3.9, 5.1, 5.4, 5.6, 5.7, 6.12, 6.13, 9.1 - 9.3, 9.8, 9.11, 9.16 - 9.19, 11.10, 11.25
- Measurement	9.4
- Movement	4.12, 5.6, 9.2, 9.6, 9.15
- Obscuration	4.5, 4.8
- Production	9.2, 9.5, 9.6, 9.10, 9.11, 9.16
- Spread	5.3, 5.10, 9.3, 9.6, 9.7, 9.11, 9.14 - 9.16,

	12.9
- Temperature	9.8, 9.16
- Yield	8.15, 8.21, 9.2, 9.8
SMOULDERING	2.3, 4.7, 5.11, 6.6, 6.7, 6.12, 7.10, 7.11, 8.3, 8.23, 11.18, 12.11
SNOW, EFFECT OF	7.12
SPANDRELS	5.4, 5.10
SPECIAL HAZARD	11.4
SPRINKLER	3.10, 4.11, 5.2, 5.4 - 5.6, 5.8, 5.10, 5.13, 6.2, 6.3, 6.7, 6.8, 6.11 - 6.13, 6.19, 6.20, 6.21, 6.23, 7.3, 8.2, 8.3, 9.4 - 9.6, 9.12, 9.16, 9.17, 11.1, 11.2, 11.4, 11.5, 11.11 - 11.15, 11.18 - 11.21, 11.23, 11.26, 13.7, 13.9
STAIR	2.1, 6.7, 9.17, 9.18
STATISTICS / STATISTICAL DATA	3.10, 6.11, 6.21, 6.28, 6.29, 7.6, 7.8 - 7.11, 8.12, 8.27, 11.20
STEEL	2.3, 3.10, 7.6, 10.8, 10.11, 10.13, 10.14
STORAGE	1.1, 5.13, 7.6, 7.7, 7.9
STRUCTURAL ADEQUACY / PERFORMANCE	3.8, 10.4, 10.10
SUB-SYSTEM	3.6 - 3.8, 3.10, 3.13, 4.5, 4.6, 5.1 - 5.4, 5.14 - 5.17, 6.2, 6.3, 6.6, 6.8, 6.9, 6.11 - 6.13, 6.16, 6.17, 6.25, 6.29, 6.30, 7.2, 7.3, 7.9, 7.15, 9.1, 9.9, 10.1, 10.3, 10.4, 10.6, 11.1, 12.1, 12.2, 12.4 - 12.8, 12.17, 12.18, 13.1, 13.4, 13.7
SUB-SYSTEM EQUIVALENCE EVALUATION / SEE (SEE LEVEL 1)	1.1, 3.8, 4.4, 4.5, 4.8, 4.10, 4.11, 5.8, 5.10, 5.14, 5.16, 6.1 - 6.3, 6.8, 6.10, 6.12, 6.16, 6.18, 6.27 - 6.30, 7.3, 7.4, 7.12, 7.16, 9.4, 9.13, 10.2, 10.3, 10.4, 10.7, 10.12, 10.13, 12.10, 12.11, 12.12, 12.14, 12.15, 12.16, 12.17, 12.20, 13.4
SUPPRESSION	1.1, 3.6, 3.9, 5.1, 5.3 - 5.6, 5.11 - 5.13, 5.17, 6.2, 6.7, 6.25, 7.1, 7.12, 8.1 - 8.3, 8.5, 8.10 - 8.12, 8.14, 8.27, 8.28, 10.2, 11.1, 11.4 - 11.11, 11.15, 11.18, 11.19, 11.21 - 11.23, 11.26, 13.2, 13.4, 13.5
SUB - SYSTEM PERFORMANCE EVALUATION / SPE (SEE LEVEL 2)	3.8, 4.4, 5.5, 6.1 - 6.3, 6.5, 6.15, 6.16, 12.9, 12.19
SYSTEM RISK EVALUATION / SRE (SEE LEVEL 3)	3.9, 4.4, 4.9, 4.10, 6.1 - 6.3, 6.5, 6.19, 6.22, 6.23, 6.25

**T**

T - SQUARED FIRE	8.6, 8.18
TIMBER	3.10, 8.19, 10.11
TIME - For Fire Attack	13.5
- For Fire Attack	13.7
- For Fire Control	13.5, 13.7
- For Fire Extinguished	13.8
- To Complete Investigations	13.2, 13.5, 13.6
- To Complete Life Safety Search / Rescue	13.5, 13.7
- To Fire Extinguishment	13.6
TIME LINE	3.8, 4.6, 6.8, 6.9, 6.24, 13.2
TOXIC SPECIES	8.1, 8.13, 8.14, 8.20, 9.8, 9.9, 9.10
TOXIC SPECIES YIELD	8.1, 8.14, 9.8
TOXICITY	4.5 - 4.8, 4.14, 9.9
TRAVEL	2.2, 2.3, 5.3, 5.17, 6.3, 6.15, 6.19, 7.3, 12.18, 13.2, 13.6
TRIAL CONCEPT DESIGN	3.1, 3.5, 3.7, 3.9, 3.10, 3.13, 4.1, 4.11, 4.13, 4.14, 5.16, 6.2, 6.3, 6.5, 6.6, 6.8, 6.10, 6.12, 6.13, 6.15, 6.16, 6.18, 6.19, 6.21, 6.28

**U**

ULTRAFAST FIRE	8.19
UNCERTAINTY	6.10, 6.11, 9.13
UNTENABILITY / UNTENABLE CONDITIONS	2.1, 3.8, 3.13, 4.3, 4.6, 5.5, 5.14, 5.15, 5.17, 6.9, 6.15 - 6.18, 6.20, 6.25, 6.26, 7.12, 8.1, 8.4, 9.1, 9.2, 9.4, 9.11, 9.13, 9.14, 9.16, 9.17, 12.1 - 12.4, 12.6, 12.7, 12.16, 12.17, 12.19
UPPER LAYER (also see hot layer)	8.16, 9.3, 9.10

**V**

VAPOUR	4.7
VENT	5.9, 7.3, 8.25, 8.26, 9.7, 9.8, 9.16, 9.17, 11.4, 11.13
VENTILATION CONTROL	8.25

VISIBILITY 4.5, 4.8, 6.16, 6.17, 8.4, 9.2, 9.4, 9.5, 9.9,  
12.2

**W**

WALL 2.3, 5.8, 5.9, 5.10, 5.13, 6.17, 7.2, 7.9, 8.3,  
8.13, 8.19, 9.11, 9.17, 10.2, 11.12, 11.13

WAREHOUSE 5.6, 7.1, 7.9, 7.10, 8.18, 8.27

WARNING SYSTEMS 5.14, 12.19

WIND 7.11, 9.3, 9.6, 9.8, 10.4, 10.12

WINDOW 4.11, 5.10, 8.2, 8.10, 8.12, 9.7, 10.11, 10.12,  
11.13

WOOD / WOOD EQUIVALENT 2.1, 7.3, 7.5, 8.16, 8.26, 10.10, 10.12, 11.3

**Z**

ZONE 8.4, 8.5, 9.5, 9.9 - 9.14, 9.16 - 9.18, 10.10,  
11.6, 11.16, 11.17, 12.16, 12.17