



Technical Report  
FCRC-TR 96-07

# Flashover Fires An Experimental Program

FCRC Project 4  
Fire Safety System Design Solutions  
Part A – Core Model & Residential Buildings

Fire Code Reform Research Program  
October 1996

## **Important Notice**

This Report has been prepared for work commissioned by Fire Code Reform Centre Limited and has been released for information only.

The statements and conclusions of the Report are those of the author(s) and do not necessarily reflect the views of Fire Code Reform Centre Limited, its Board of Directors or Members.

Neither the authors, Fire Code Reform Centre Limited, nor the organisations and individuals that have contributed, financially or otherwise, to production of this document warrant or make any representation whatsoever regarding its use.

## **Background**

The Fire Code Reform Research Program is funded by voluntary contributions from regulatory authorities, research organisations and industry participants.

Project 4 of the Program involves development of a Fundamental Model, incorporating fire-engineering and risk-assessment methodology, for performance prediction of building fire safety system designs in terms of Expected Risk to Life (ERL) and Fire Cost Expectation (FCE). Part 1 of the Project relates to Residential Buildings as defined in Classes 2 to 4 of the Building Code of Australia.

Preparatory to development of the Model a significant Experimental Fire Test Program was undertaken in realistic residential layouts at VUT's Fire Test Facility, Fiskville, Victoria. This Technical Report was prepared following completion of that part of the Experimental Program that related to Flashover Fires.

## **Acknowledgements**

Since inception of the Fire Code Reform Research Program in 1994 the Australian Building Codes Board has been its principal financial contributor. Substantial funds have also been provided by Forest and Wood Products Research and Development Corporation and generous contributions have been received from a number of industrial and financial entities and individual donors.

The Board and management of Fire Code Reform Centre Limited acknowledge with sincere gratitude receipt of all these financial contributions. The company also acknowledges the kind permission to re-produce and publish this document received from the Centre for Environmental Safety and Risk Engineering at Victoria University of Technology.

## **Comments**

Comments on the content or other aspects of this document are always welcome and should be addressed to:- Fire Code Reform Centre Limited, Suite 1201, 12<sup>th</sup> Floor, 66 King Street, Sydney, NSW 2000, Australia. Tel: +61 (2) 9262 4358 Fax: +61 (2) 9262 4255

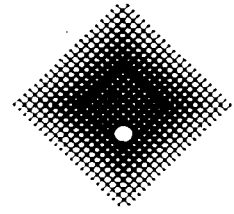

# **Flashover Fires -An Experimental Program**

**Teresa Alam  
Paula Beever**

**RESEARCH REPORT**

Centre for  
Environmental  
Safety & Risk  
Engineering

**October 1996  
CESARE Report 96-002**



# **FLASHOVER FIRES - AN EXPERIMENTAL PROGRAM**

**A Project Funded by the  
FIRE CODE REFORM CENTRE LTD**

**as part of**

**FCRC PROJECT 4**  
**FIRE SAFETY SYSTEM DESIGN SOLUTIONS FOR THE BCA**

**PART 1:- CORE MODEL AND RESIDENTIAL BUILDINGS  
-CLASS 2-4 BUILDINGS**

**By**  
**Teresa Alam and Paula Beever**

**Center For Environmental Safety And Risk Engineering**

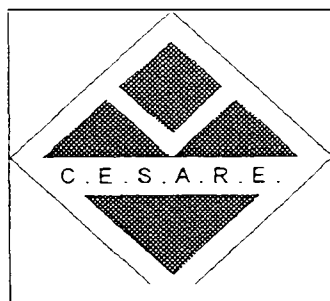

**Victoria University of Technology**

**CESARE Report No. R96-002  
October 1996**

**Copyright © 1996 Victoria University of Technology**



# CONTENTS

1. Introduction	1
2. Scope	1
3. The Experimental Building Fire Facility (EBFF)	2
3.1 Building structure	2
3.2. Burn Room Size & Characteristics	9
3.3. Air Handling, Smoke Management and Stair Pressurisation Sub System	10
3.4. Sprinkler Specifications	11
4. Flashover Test Series Outline	13
4.1 Fuel Load Specifications	13
4.2. Ignition Source	18
4.3. window Lowering Criteria	19
4.4. Test Schedule	19
4.5 Combustible Wall Linings	20
5. Instrumentation	21
5.1. Data Logging System	21
5.2. Heat Flux Transducers	21
5.3. Mass Loss Platforms	21
5.4. Smoke/Heat Detectors & Smoke Densitometers	22
5.5. Thermocouples	22
5.6. Chemical Analysers	22
5.7. Video Recording	23
5.8. Ambient Weather Monitor	23
6. Location of Instrumentation	24
6.1. Burn Room	24
6.1.1. Return Air Duct	25
6.1.2. Timber and Steel Stud Plaster Board Wall	25
6.2. Corridor Outside Burn Room (Level 1)	25
6.3. Level 1, 1M, 2 and 3 Stairwells	26
6.4. Levels 1M and 2	27
6.5. Level 3	28
6.6. External Instrumentation	30
7. General Pictorial Guide to the Fire Tests	32
8. Graph Descriptions	37
8 . 1 General	37
8.1. Mass Loss and Heat Release Rate	37
8.2. Average, Maximum and Minimum Burn Room Temperatures	37
8.3. Heat Flux	37
8.4. Gas Species Concentrations at various locations	38

8.5. <i>Flow Velocity</i>	39
8.6. <i>Differential Pressure</i>	39
8.7. <i>Optical Density</i>	39
8.8. <i>External Temperature</i>	39
9. Flashover Test FO1	40
10. Flashover Test F02	60
11. Flashover Test F03	80
12. Flashover Test F04	100
13. Flashover Test F05	120
14. Flashover Test F06	140
15. Flashover Test F07	160
16. Flashover Test FO8	180
17. General Discussion	200
17.1. <i>Burn Room</i>	200
17.1 <i>Repeatability- F02 &amp; FO3</i>	203
17.2 <i>Burn Room Door</i>	204
17.3 <i>Level 1 Corridor and Stairwell Door</i>	204
17.4 <i>Stairwell Levels 1, 1M, 2 and 3</i>	204
17.5 <i>Levels 1M and 2</i>	205
17.6 <i>Level 3</i>	205
17.7 <i>External Results</i>	205
18. Conclusions	206
19. Recommendations	207
19. Acknowledgments	208
20. References	208

## LIST OF APPENDICES

Appendix 1-Fuel Load Statistics
Appendix 2- Air Handling/Smoke Management Control Commissioning Report
Appendix 3-AWTA Textiles Testing Report
Appendix 4- Window Lowering Criteria
Appendix 5- Effective Heat of Combustion Calculations

## LIST OF TABLES

Table 1: Supply and Return Air Rates	11
Table 2: Weight of Fuel Load	13
Table 3: Composition of Lounge Suite	14
Table 4: Conditions for Fire Tests	19
Table 5: Maximum Calibrated Range for CO Analysers	38
Table 6: Maximum Calibrated Range for CO <sub>2</sub> Analysers	3s
Table 7: Summary of FO1 Results	40
Table 8: Summary of F02 Results	60
Table 9: Summary of F03 Results	80
Table 10: Summary of F04 Results	100
Table 11: Summary of F05 Results	120
Table 12: Summary of F06 Results	140
Table 13: Summary of F07 Results	160
Table 14: Summary of FO8 Results	180
Table 15: Summary of Sprinkler Activation Times	201
Table 16: Summary of Detector Activation Times	202
Table 17: Summary of Ventilation Conditions and Time to Flashover	202

## LIST OF FIGURES

Figure 1: Experimental Building Fire Facility	3
Figure 2: EBFF- South Side Facade	3
Figure 3: Level 1 Floor Plan	4
Figure 4: Level 1M Floor Plan	5
Figure 5: Level 2 Floor Plan	6
Figure 6: Level 3 Floor Plan	7
Figure 7: Southern Elevation	8
Figure 8: Plan View of the Bum Room	9
Figure 9: South Wall Window (W102)	10
Figure 10: Supply and Return Air Duct Locations on Level 1	10
Figure 11: Sprinkler Locations in the Bum Room	12
Figure 12: Fuel Load Layout in the Bum Room	15
Figure 13: Fuel Load Layout in the north-west side of the Bum Room	16
Figure 14: Fuel Load Layout in the north-east side of the Bum Room	16
Figure 15: Fuel Load Layout in the south-west side of the Bum Room	17
Figure 16: Ignition Point on the Three Seater Couch	18
Figure 17: Combustible Lining location in Level 1 corridor	20
Figure 18: East-west thermocouple rack in the bum room	24
Figure 19: North-south thermocouple rack in the bum room	24
Figure 20: Thermocouple Tree in the bum room door	25
Figure 21: Instrumentation layout on Level 1	27
Figure 22: Instrumentation layout on Level 1M	28
Figure 23: Instrumentation layout on Level 2	28
Figure 24: Instrumentation layout on Level 3	29
Figure 25: Elevation of the instrumentation layout	29
Figure 26: Instrumentation layout on the external facade of EBFF	30

Figure 27: Thermocouple grid on the south wail of EBFF	31
Figure 28: Initial Stage of fire	32
Figure 29: Initial bowing of the middle pane of the bum room window	32
Figure 30: Severe bowing of the bum room window	33
Figure 31: Window is lowered	33
Figure 32: Approximately 2 minutes after bum room window was lowered	34
Figure 33: Flashover (View 1)	34
Figure 34: Flashover (View 2)	35
Figure 35: Decay (View 1)	36
Figure 36: Decay (View 1)	36
Figure 37: External thermocouple grid	39
Figure 38: Average bum room temperature for F02 & F03	203
Figure 39: Mass Loss on each platform in the bum room for FO2 & FO3	203

### LIST OF GRAPHS

*Note: The graph figures are the same for all the tests- x denotes test 1 to 8.*

Figure FOx-1: Combined mass loss in the bum room
Figure FOx-2: Total heat release rate in the bum room
Figure FOx-3: Average, maximum and minimum temperatures in the burn room
Figure FOx-4: Oxygen concentration and average temperature in the bum room
Figure FOx-5: Total heat flux in the center of the bum room
Figure FOx-6: Carbon monoxide concentration along the center line of the bum room door
Figure FOx-7: Carbon dioxide concentrations along the center line of the burn room door
Figure FOx-8: Oxygen concentrations along the center line of the bum room door
Figure FOx-9: Flow velocity distribution at the center line of the burn room door
Figure FOx-10: Temperature distribution along the center line of the bum room door
Figure FOx-11: Temperature along Level 1 corridor (2.0 m above the floor)
Figure FOx-12: Temperature along Level 1 corridor (1.5 m above the floor)
Figure FOx-13: Temperature along Level 1 corridor (0.5 m above the floor)
Figure FOx-14: Vertical temperature distribution in the center of Level 1 corridor
Figure FOx-15: Temperature distribution along the center line of Level 1 stairwell door
Figure FOx-16: Flow velocity distribution at the center line of Level 1 stairwell door
Figure FOx-17: Oxygen concentration at the stairwell doors (1.7 m above the floor)
Figure FOx-18: Carbon dioxide concentration at the stairwell doors (1.7 m above the floor)
Figure FOx-19: Carbon monoxide concentration at the stairwell doors (1.7 m above the floor)
Figure FOx-20: Temperature in the stairwell at each level -North side (1.7 m above the floor)

- Figure FOx-21: Temperature in the stairwell at each level-South side(1.7 m above the floor)**
- Figure FOx-22: Optical density/m at six locations (1.7 m above the floor)**
- Figure FOx-23: Pressure differences between outside and the stairwell at each level (1.7 m above the floor)**
- Figure FOx-24: Temperature distribution along the center line of Level 1M stairwell door**
- Figure FOx-25: Temperature distribution along the center line of Level 2 stairwell door**
- Figure FOx-26: Temperature distribution along the center line of Level 3 stairwell door**
- Figure FOx-27: Temperature distribution along Level 1M corridor (1.7 m above the floor)**
- Figure FOx-28: Temperature distribution along Level 2 corridor (1.7 m above the floor)**
- Figure FOx-29: Temperatures in Room 201 (1.7 m high)**
- Figure FOx-30: Temperature distribution along Level 3 corridor (1.7 m above the floor)**
- Figure FOx-31: Vertical temperature distribution in the center of Level 3 corridor**
- Figure FOx-32: External temperature along the center line of the burn room window (0.02 m from the wail)**
- Figure FOx-33: External temperature along the center line of the burn room window (0.5 m from the wall)**
- Figure FOx-34: External temperature along the center line of the burn room window (1.0 m from the wall)**
- Figure FOx-35: External temperature along the center line of the burn room window (1.5 m from the wail)**
- Figure FOx-36: External heat flux measurements (Refer to Figure 25 for locations)**

*Graphs sets for each test are located at :*

- Flashover Test FO1 - pp 42-59**
- Flashover Test F02 - pp 62-79**
- Flashover Test F03 - pp 82-99**
- Flashover Test F04 - pp 102-119**
- Flashover Test F05 - pp 122-139**
- Flashover Test F06 - pp 142-159**
- Flashover Test F07 - pp 162-179**
- Flashover Test FO8 - pp 182-199**

# 1. INTRODUCTION

This test series is the second and final phase of the Fire Code Reform Centre (FCRC) Research Project - Project 4, Fire Safety Design Solutions for the BCA - Part 1 - Core Model and Residential Buildings, Class 2 - 4 Buildings. Phase 1 examined smouldering and flaming fires [1], and was funded by the Australian Building Research Grants scheme. The purpose of Phase 2 was to conduct realistic fire experiments involving flashover fires. This phase of the project was funded by the Fire Code Reform Centre Ltd and was conducted at the Centre for Environmental Safety and Risk Engineering (CESARE) Experimental Building-Fire Facility (EBFF).

The purpose of these tests was to collect comprehensive experimental data which will be used to validate computer models of fire growth, development and spread through a realistic building layout.

The total number of experiments conducted was eight. Initially there were seven experiments detailed in the contract, but an additional test was added to the series when the air handling test with both the burn room door and the stairwell door did not proceed to flashover. This additional test also had air handling on, but the burn room door and the stairwell door were closed. The only difference between each of these fire tests was the ventilation conditions, which are described in the body of the report. The fuel load in the burn room was approximately 30 kg/m<sup>2</sup> (wood equivalent mass). Commercially available furniture was used in all the tests.

This report contains a description of the fire tests conducted and the results obtained.

# 2. SCOPE

The scope of this project was to conduct real fire experiments for class 2-4 buildings. The Building Code of Australia (BCA) defines Class 2 - 4 buildings as :

- Class 2            A building containing 2 or more sole occupancy units each being a separate dwelling excluding Class 1.
  
- Class 3            A residential building other than Class 1 or 2 which is a common place of living of a number of unrelated persons, including -
  - (a) Boarding house, guest house, hostel, lodging house
  - (b) Residential part of a hotel or motel
  - (c) Residential part of a school
  - (d) Accommodation for the aged, disabled or children
  - (e) Residential part of a health care building which accommodates members of staff
  
- Class 4            A dwelling in a building that is Class 5,6,7,8 or 9 if it is the only dwelling in the building.

The parameters measured and recorded during each of the experiments at various locations (described in detail in Section 6) throughout the building included:

- Fuel Mass Loss in Burn Room
- Temperature
- Gas Species Concentrations
- Air Velocity
- Total Heat Flux
- Smoke Optical Density
- Pressure Difference
- Time of Sprinkler Activation
- Time of Detector Activation

Not all of the data is presented in this report due to the extensive amount collected. Also the data presented has been subjected to smoothing and averaging.

### **3. THE EXPERIMENTAL BUILDING-FIRE FACILITY (EBFF)**

#### ***3.1 Building Structure***

The EBFF is a three storey building with a mezzanine floor between Level 1 and 2 which is referred to as Level 1M. This mezzanine floor was constructed to reduce the 5.2 m inter floor height between Level 1 and 2 to a level more representative of domestic rooms. The floor to ceiling height of the rooms on levels 1, 1M, 2 and 3 are 2.4 m, 2.35 m, 2.7 m, and 2.4 m respectively. The layout of the building is representative of an apartment building. On Levels 1, 1M and 2 there are four rooms and a corridor; Level 3 is simply a corridor. There is a services area on every level, which contains a lift shaft, staircase, air handling shafts and other services including sprinkler pipework. The layout of each level in the EBFF is shown in Figures 3 to 7 and photographs of the facade are shown in Figures 1 and 2.

The structure of the building is made up of steel sections with the main floors constructed from suspended concrete slabs. The plan area of the EBFF is 21 m × 15 m and has a total height of 12 m. The walls in the service area are lined with lightweight aerated concrete blocks and the walls in the rest of the building are lined with standard 16 mm fire rated plaster board attached to steel studs. The external walls are steel clad with only the south side being clad with 9 mm cement sheeting. The south facade which is exposed to fire has additional covering to protect it from the flame and heat.

The EBFF is equipped with an air handling system servicing Levels 1, 1M and 2, which is designed to operate as smoke management and a stair pressurisation sub system in the case of fire. In normal operation the air handling system can provide non-conditioned air into each room at a rate of approximately 50 l/s. The supply air and extraction rates (return air) are detailed in Section 3.2 and in the systems commissioning report (Appendix 2).

The EBFF is also equipped with a sprinkler system which services Levels 1, 1M and 2. The system is serviced and can operate at various pressures.

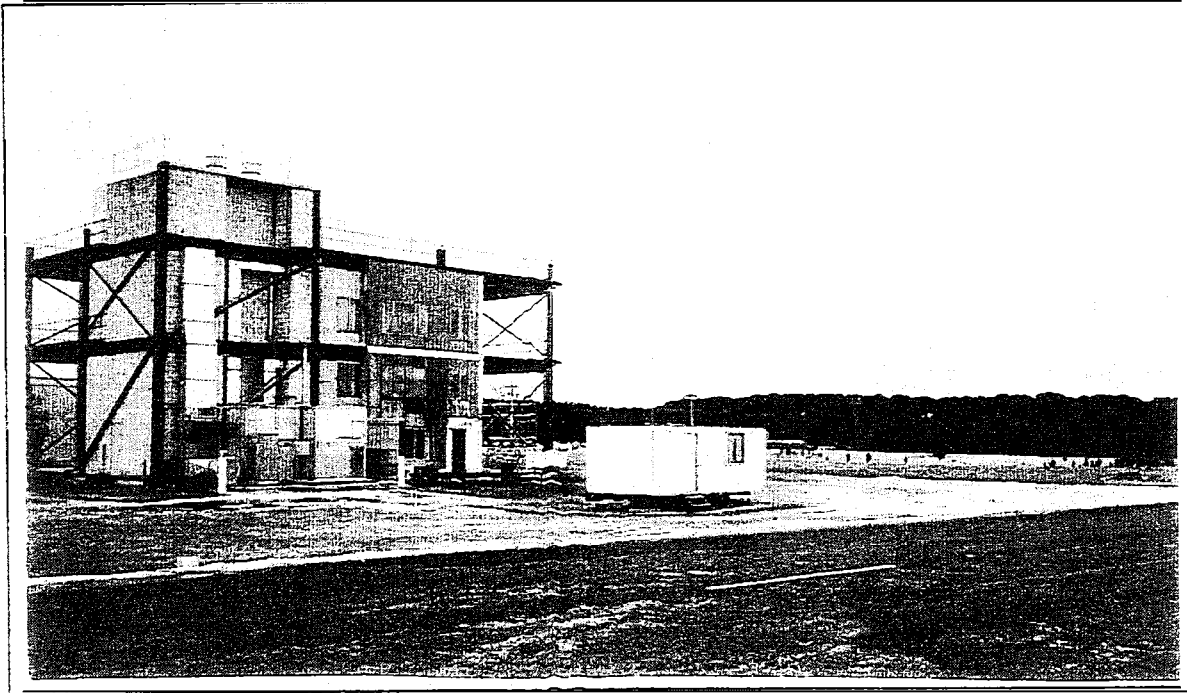

**Figure 1: Experimental Building-Fire Facility**

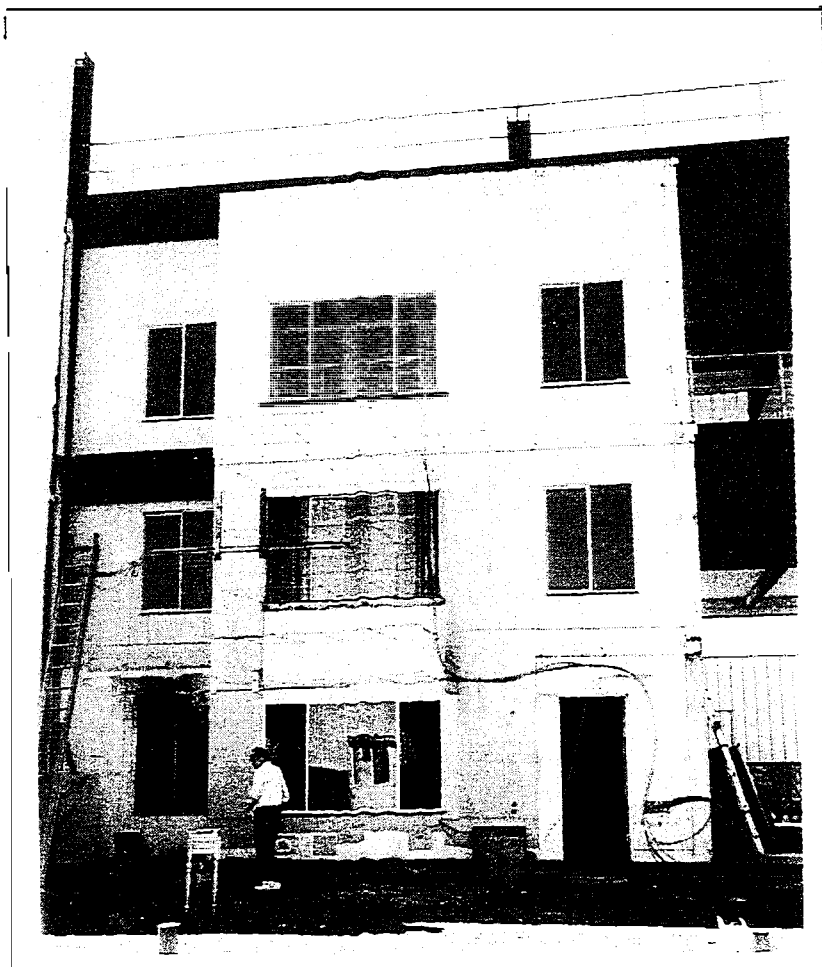

**Figure 2: EBFF- South Side Facade**





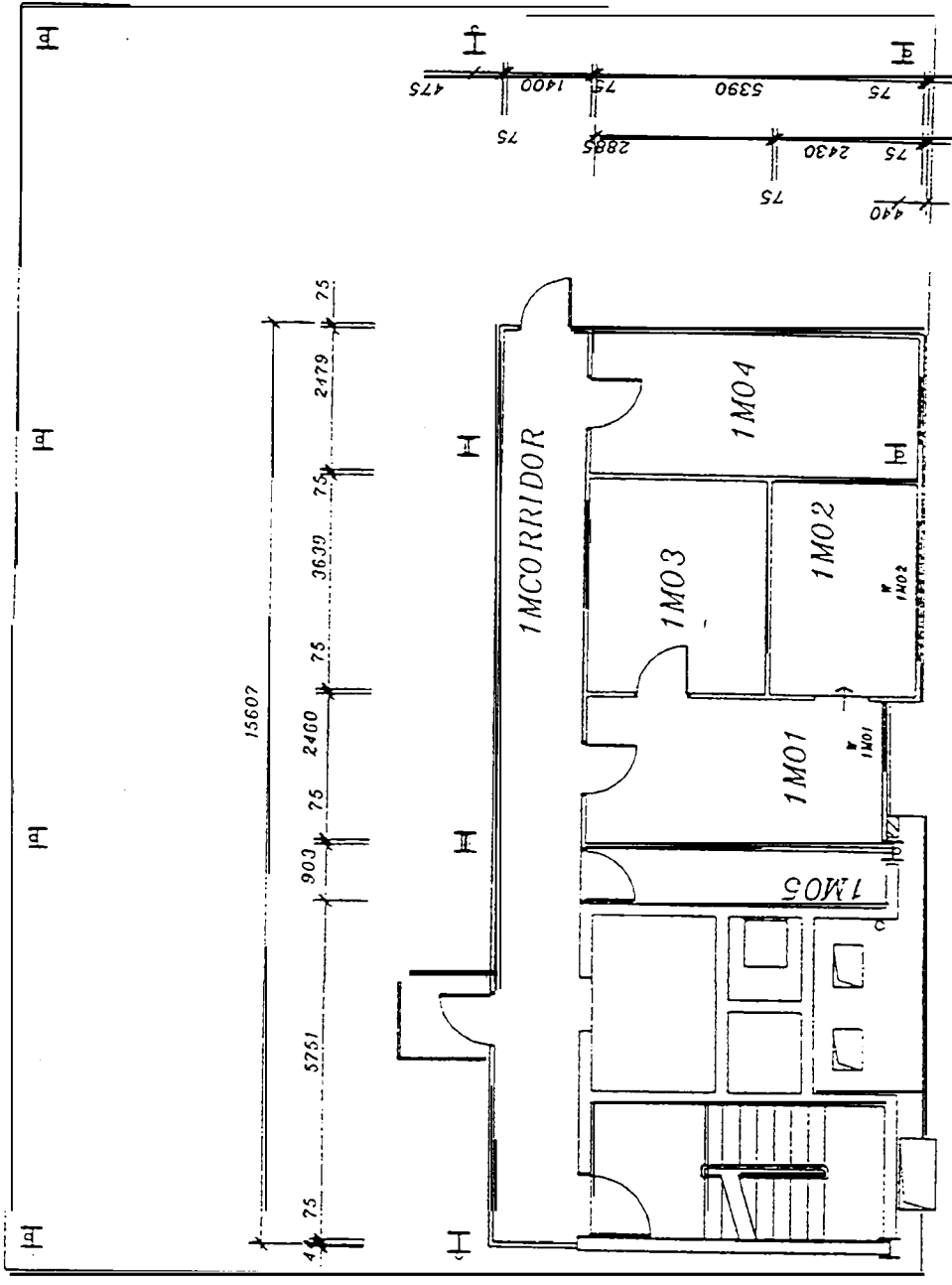

Figure 4: Level 1M Floor Plan

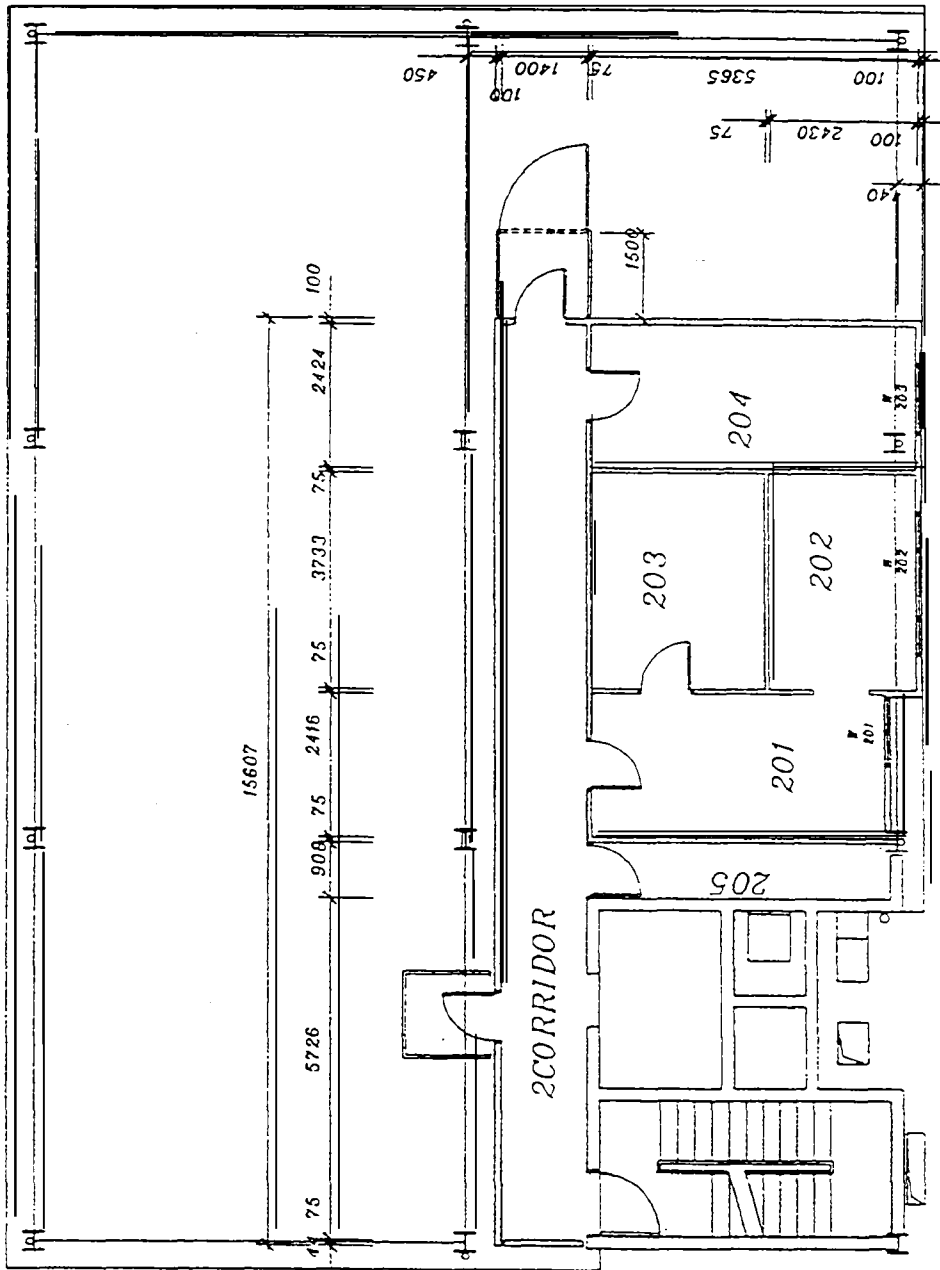

Figure 5: Level 2 Floor Plan

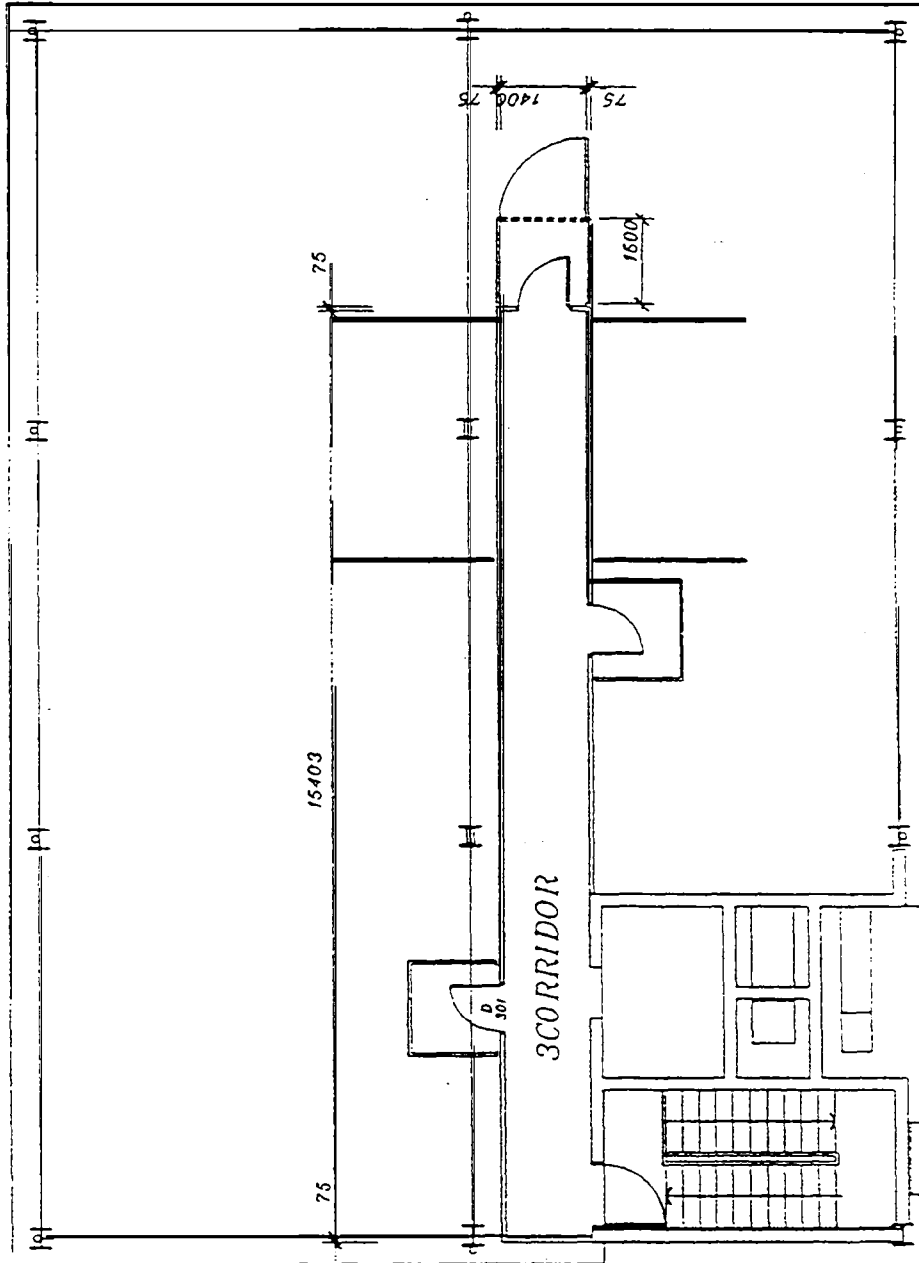

Figure 6: Level 3 Floor Plan

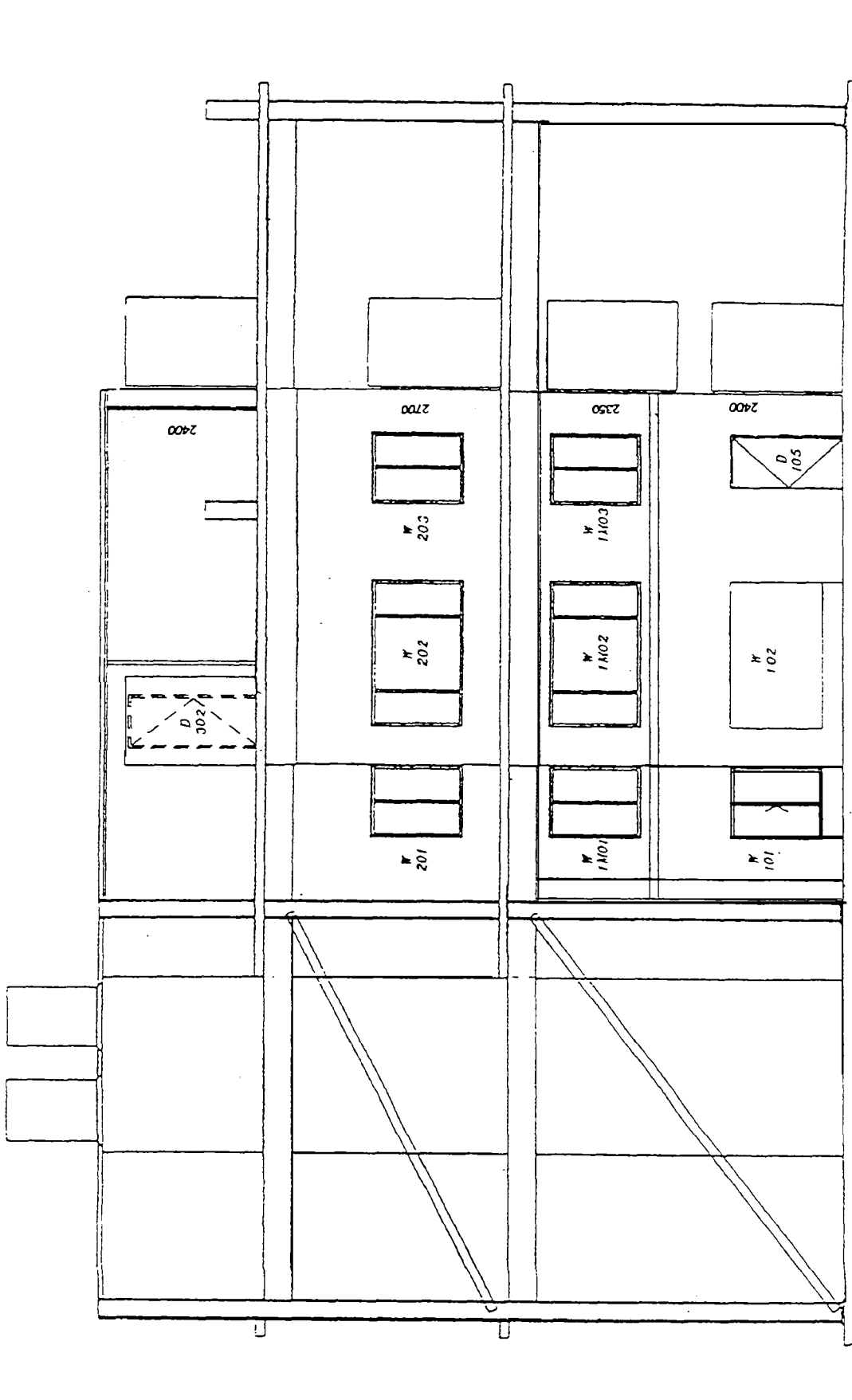

Figure 7: Southern Elevation

### 3.2 Burn Room Size & Characteristics

The flashover fires experiments were conducted on Level 1 in a large burn room (5.4 m x 3.6 m x 2.4 m), denoted as Room 102 in Figure 3. A standard size door, D 1, (820 mm x 2040 mm), is located in the center north face of the room. A one hour fire rated door is fitted in the frame, with a 15 mm gap at the base of the door for all closed door experiments. Opposite this door is a 2400 mm x 1500 mm window, W 102, in a standard three pane configuration (2 small sliding panels, 3 mm thick and one fixed glass sheet, 4 mm thick) as shown in Figure 9. When this window was closed no natural draught through the room was detected. The burn room walls were lined with 2 layers of 16 mm fire rated plaster except on the north wall which is described later and the ceiling was lined with 3 layers of 16 mm fire rated plaster. It was decided to use this extra lining in the burn room to ensure the fire would not spread to adjacent rooms and to the levels above as this experimental series was concerned with smoke and fire spread via openings rather than through barrier failures. For the test where the sprinkler was charged with water (FO8) there was only 1 layer of plaster on the walls and 2 layers of plaster on the ceiling.

The north wall (which contains the door to the corridor) was constructed in two parts- one side of the wall was replaced with a timber frame section and the other half was made up of a standard steel frame, as shown in Figure 8. A single layer of 16 mm fire rated plaster lined both sides of the wall to form a standard 1 hour fire rated wall. The door to the corridor was not attached to the frame during tests which had the door in the open position.

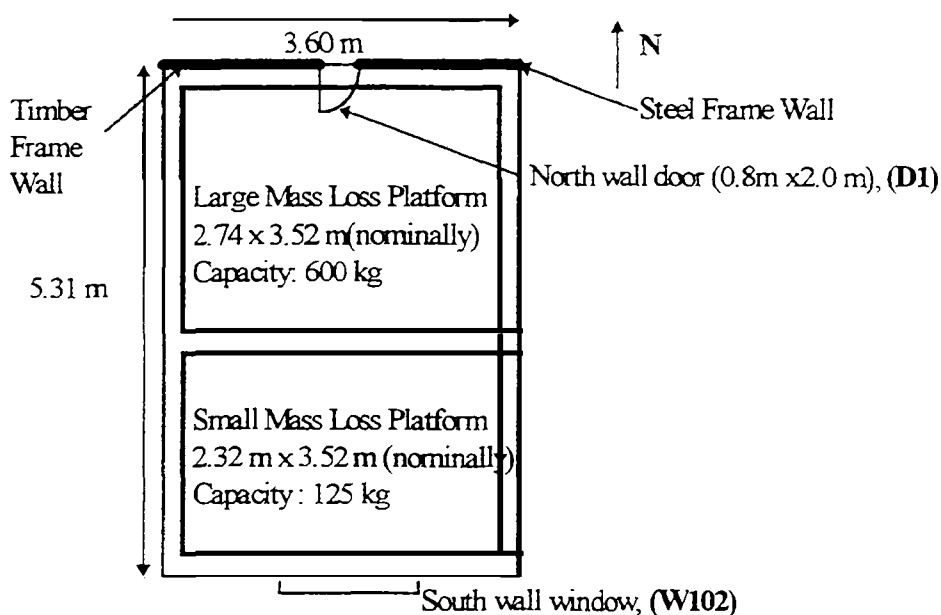

Figure 8: Plan View of the Burn Room

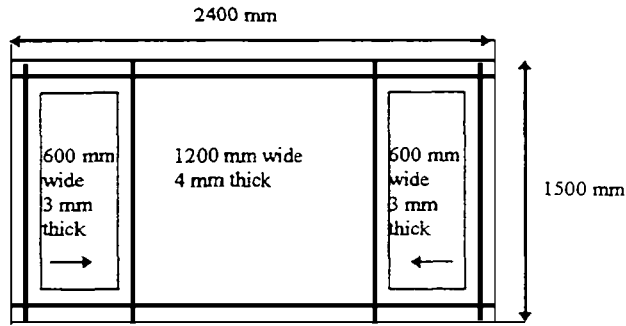

Figure 9: South Wall Window (W102)

### 3.3 Air Handling, Smoke Management and Stair Pressurisation Sub Systems

In the case where air handling was specified to be on, the normal supply and return air is switched on prior the start of the test. The smoke management and stair pressurisation sub systems were activated immediately upon the activation of the high sensitivity photo-optical detector located within the return air duct. Level 1 (floor of fire origin) would then be at a lower pressure than all the above levels as a result of closing all the supply air dampers; the return air damper remains open (smoke extraction mode). The supply air dampers to all other levels would remain open but the return air dampers would be closed. The time taken for the dampers to fully open/close was approximately 2 minutes. On activation of the photo-optical detector the stair pressurisation and smoke extraction fans were switched on to high. This arrangement was in accordance with the requirements for smoke control systems as specified in the Building Code of Australia.

Locations of the supply and return air ducts on Level 1 are shown in Figure 10. The size of the supply air ducts are typically 210 mm x 215 mm.

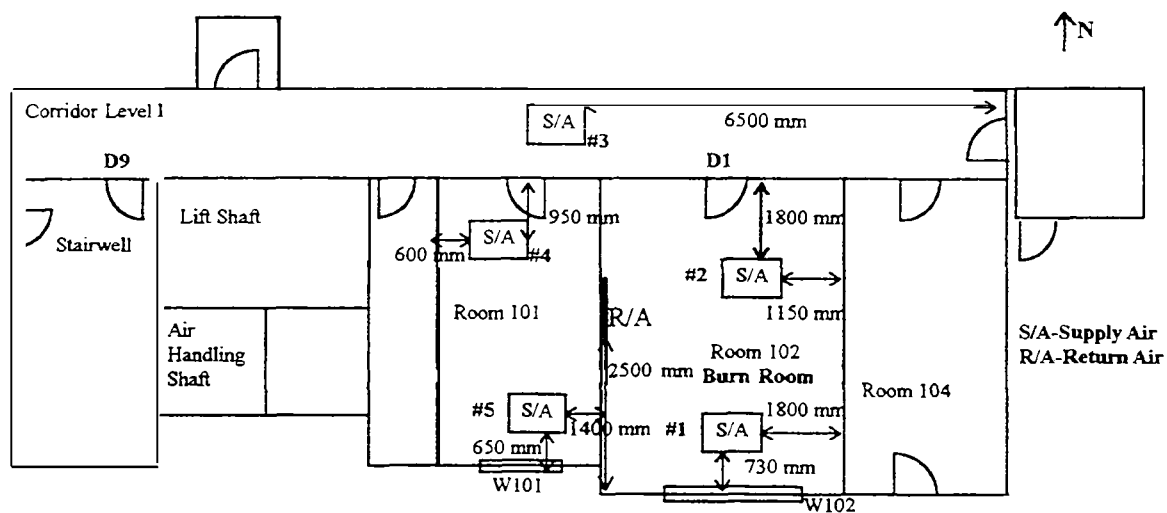

Figure 10: Supply and Return Air Duct Locations on Level 1

There was only one return air duct located on Level 1 in the wall between Room 101 and 102. The size of the return air duct was 440 mm x 330 mm and was located 240 mm from the ceiling in the center of the wall.

The supply and extraction rates for the system in various ventilation conditions are shown in Table 1 and are detailed further in the systems commissioning report, (Appendix 2).

**Table 1: Supply and Return Air Rates**

Supply Air Duct	Flow (l/s)
#1	46
#2	50
#3	51
#4	35
#5	35
Return Air Duct	Flow (l/s)
Burn Room Door Closed (D1) Stair Door Closed (D9)	494
Burn Room Door Open (D1) Stair Door Open (D9)	1321

### 3.4 Sprinkler Specifications

In the case where sprinklers are specified to be charged with water, only the two sprinklers in the burn room are configured to actually discharge water.

The sprinkler type was chosen according to AS 2 118 Part 1-1995, “Automatic fire sprinkler systems” as this was considered the most relevant part for the purpose of the experiment. Other parts of the code were also looked at but were not suitable- most notably Part 4 which covers Residential sprinkler systems but only residential buildings containing not more than four storeys and Part 5 which covers buildings defined as Class 1 by the Building Code of Australia, (BCA).

The sprinkler system was designed for a Light Hazard Occupancy as defined by AS 2 118.1-1995 Section 2 (2.2.2). This covered most of the Class 3 occupancies as according the BCA.

The actual system was designed according to Section 9 “Light Hazard Class Systems” of the above Standard. There are two charged sprinklers in the burn room as shown in Figure 11. These sprinklers are fitted with 10 mm nominal bore (3/8” BSP), 68°C bulb type heads. The minimum pressure at each head is specified to be 70 kPa, which corresponds to a discharge of 48 l/min. This gives a density of discharge of 5.0 mm/min



in the burn room. These heads were positioned with the water diffuser at 85 mm from the ceiling.

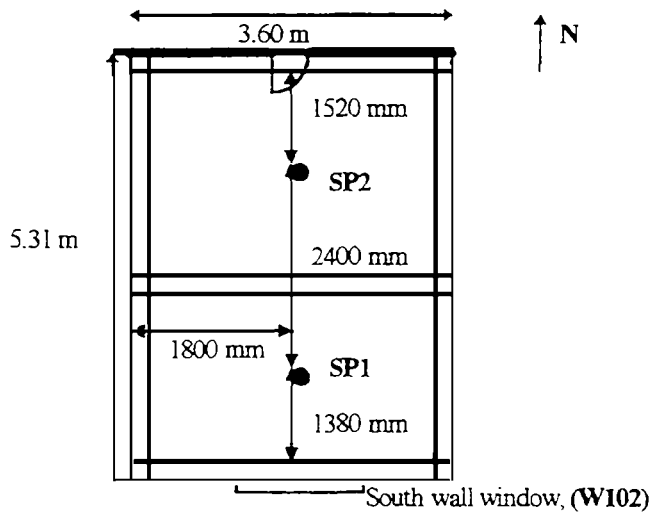

**Figure 11: Sprinkler Locations in the Burn Room**

A third sprinkler (SP3) is located in the center of Level 1 corridor 900 mm away from the western edge of the burn room door. This sprinkler is not charged with water for any of the fire tests. When the system is not charged with water the fire is allowed to grow freely and the activation time (bulb breakage) is recorded as an indicator only. The glass bulb breakage time is recorded by a sensing wire (thermocouple).

## 4. FLASHOVER TEST SERIES OUTLINE

### 4.1 Fuel Load Specifications

This series of flashover fire tests are modelled on a lounge/living room situation and are a realistic reproduction of a typical situation. The target fuel load was  $30 \text{ kg/m}^2$  ( in wood equivalent weight). This value was decided on after considering various statistics and surveys of apartments/residencies, (Appendix 1). The fuel load is described in greater detail in Table 2 below and the layout is shown in Figures 12, 13, 14 & 15. The conversion to wood equivalent mass is based on a heat of combustion of wood of  $18.4 \text{ MJ/kg}$ .

Table 2: Weight of Fuel Load

	Mass (kg)	Heat of Combustion (MJ/kg)	Wood Equivalent Mass (kg)
<i>Small Platform</i>			
<b>3 Seater Couch</b>	47.76	18.6	48.28
<b>Coffee Table</b>	20.08	18.4	20.08
<b>Carpet &amp; Underlay</b>	Total = 34.42	53.7	100.45
<b>Total</b>	<b>102.26</b>		<b>168.81</b>
<i>Large Platform</i>			
<b>Chair</b>	22.82	21.4	26.54
<b>Chair</b>	22.42	21.4	26.08
<b>Bookcase</b>	33.12	18.4	33.12
<b>Bookcase</b>	33.10	18.4	33.10
<b>Coffee Table</b>	21.02	18.4	21.00
<b>Carpet &amp; Underlay</b>	Total = 40.44	53.7	118.02
<b>In Bookshelf:</b>	138 x 2 = 265.2 Modified total mass: 138.00	18.4	138.00
<b>On Coffee Table:</b>	3.90		3.90
<b>Total</b>	<b>442.02</b>		<b>399.94</b>
<b>Total in Bum Room</b>	<b>544.28</b>		<b>568.75</b>

Any differences in fuel load between fire tests can be accounted for through the variation in the weight of the telephone books and the fact that the same piece of furniture does not weight exactly the same due to slight variations during manufacture. The fuel load in this flashover test series varied between  $29 \text{ kg/m}^2$  and  $29.3 \text{ kg/m}^2$ .

The coffee tables and the bookcases are made of untreated raw pine. The carpet was registered as “Domestic Heavy Duty”. The pile fibre was a blend of 80% wool and 20% polypropylene and there were no treatments added to it such as Scotchguard. It has a nominal weight of 1.047 kg/m<sup>2</sup>. The underlay is made of natural latex rubber.

The composition of the 3 seater couch and the two single seaters is shown in Table 3. The pine used is a kiln dried radiata pine, the plywood is a Pinus structural plywood, the Dacron is 100% polyester fibre, the webbing is a blend of rubber (43.9%) and polyolefin (56.1%) and the foam is a Joyce H30-100 polyurethane foam. The fabric covering is a blend of five fibres. The pile is 74.5% nylon and 25.5% acrylic. The backing is a combination of cotton, bast and polyester.

All fabrics, including the carpets, used in the fire tests have been analysed for their composition by the Australian Wool Testing Authority, Textiles Division. The results are shown in Appendix 3.

**Table 3: Composition of Lounge Suite**

<b>Item</b>	<b>Single Chair Mass (kg)</b>	<b>3 Seater Couch Mass (kg)</b>
Pine Frame	10.00	15.00
Partial Board Seat Frame	3.40	7.20
Plywood Arms	1.70	1.70
Foam	2.10	7.50
Dacron	2.35	5.87
Fabric	1.50	4.00
Webbing	0.10	0.30
Fasteners	0.25	0.25
<b>TOTAL</b>	<b>21.40 kg</b>	<b>41.82 kg</b>

The effective heat of combustion for the single chair and the three seater couch was calculated using the weight and component values in Table 3 and are shown in detail in Appendix 5

The telephone books on the bookshelf were spaced evenly horizontally 4 across each shelf. They were stacked from the bottom to the top self at heights of 3, 3, 3, 3, 3, 2 respectively. Each book weighted approximately 1.95 kg. The two books on the coffee table were spaced evenly apart along the center of the coffee table. This is shown in Figures 13, 14 & 15.

There was also a strip of carpet and underlay 150 mm wide along the center of the room between the two mass platforms weighting 1.56 kg. Although the mass loss of this piece of carpet and underlay was not measured it only represented 0.2% of the overall fuel load in the room and it was considered far more important to ensure spread across the two platforms.

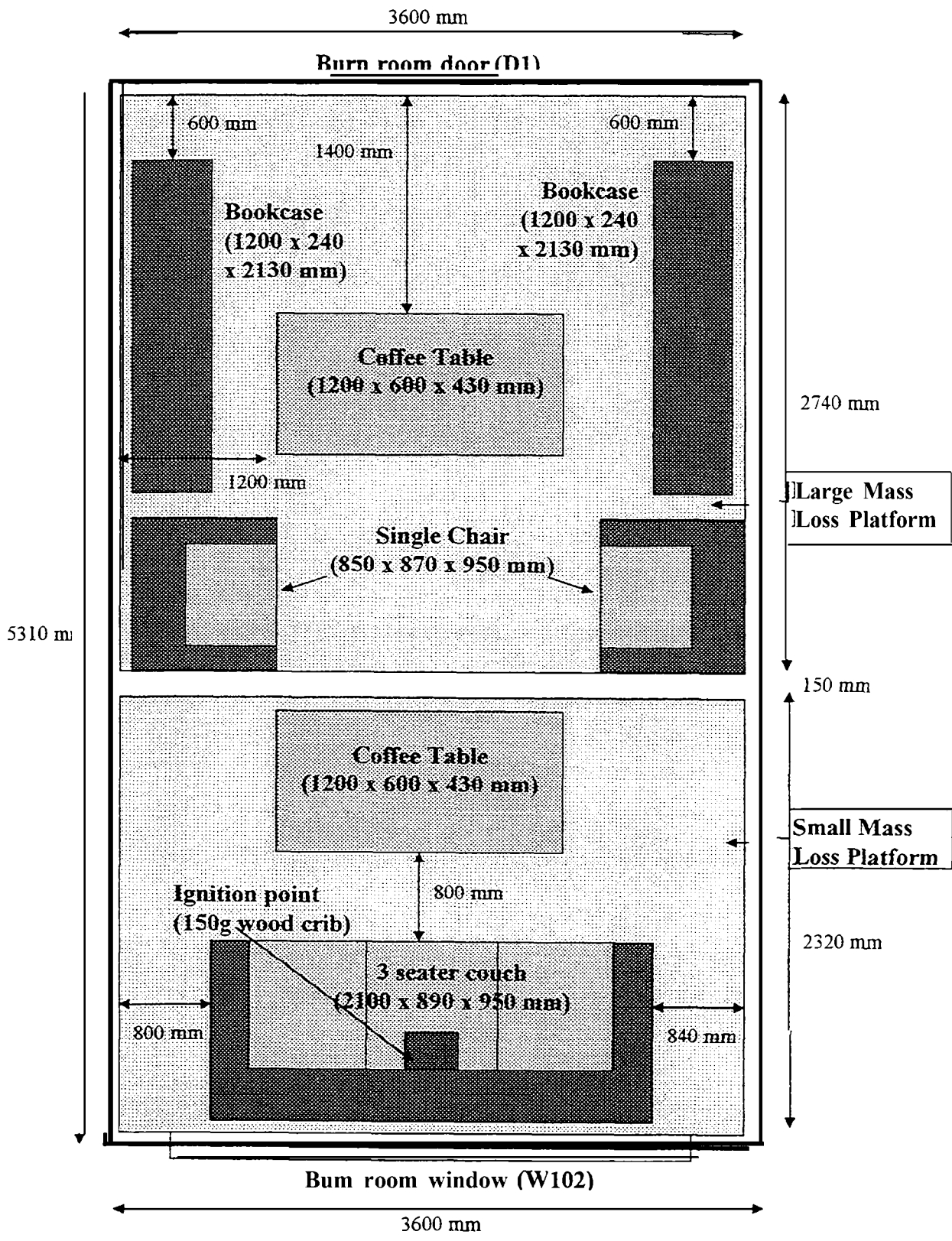
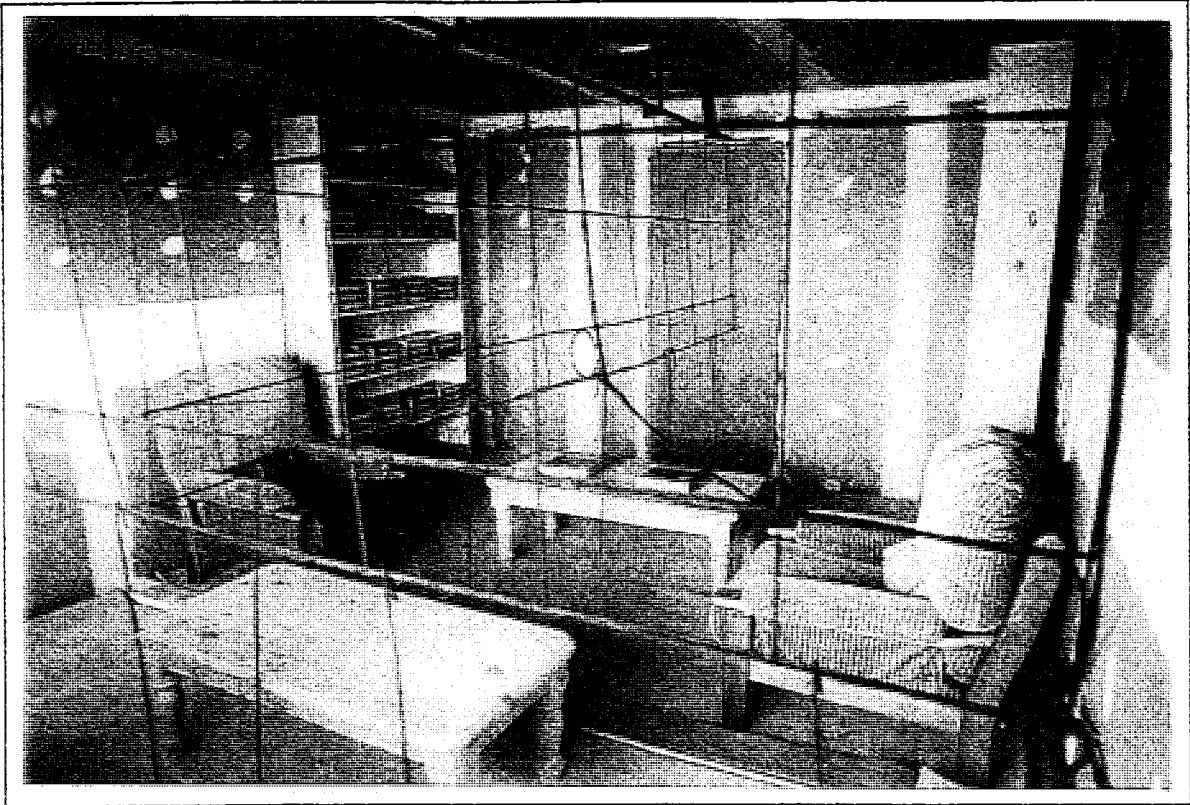
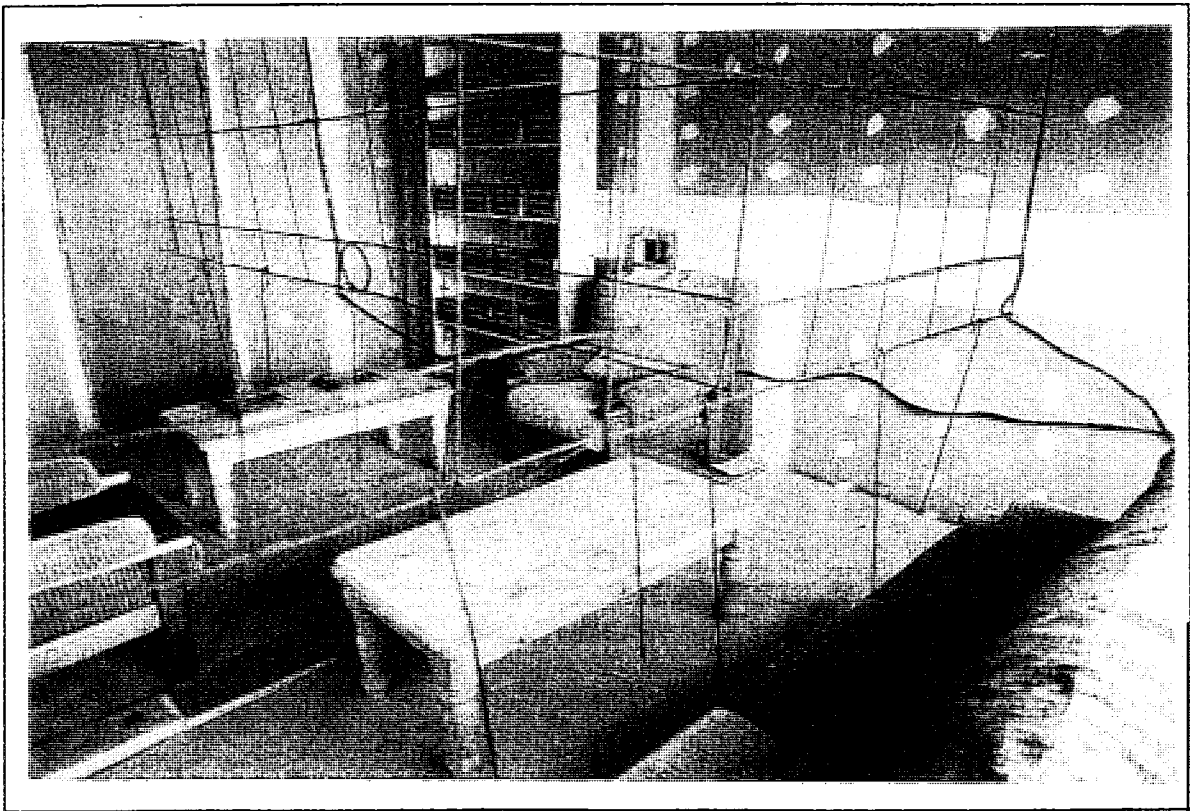

Figure 12: Fuel Load Layout in the Bum Room



**Figure 13: Fuel Load Layout in the north-west side of the Burn Room**



**Figure 14: Fuel Load Layout in the north-east side of the Burn Room**

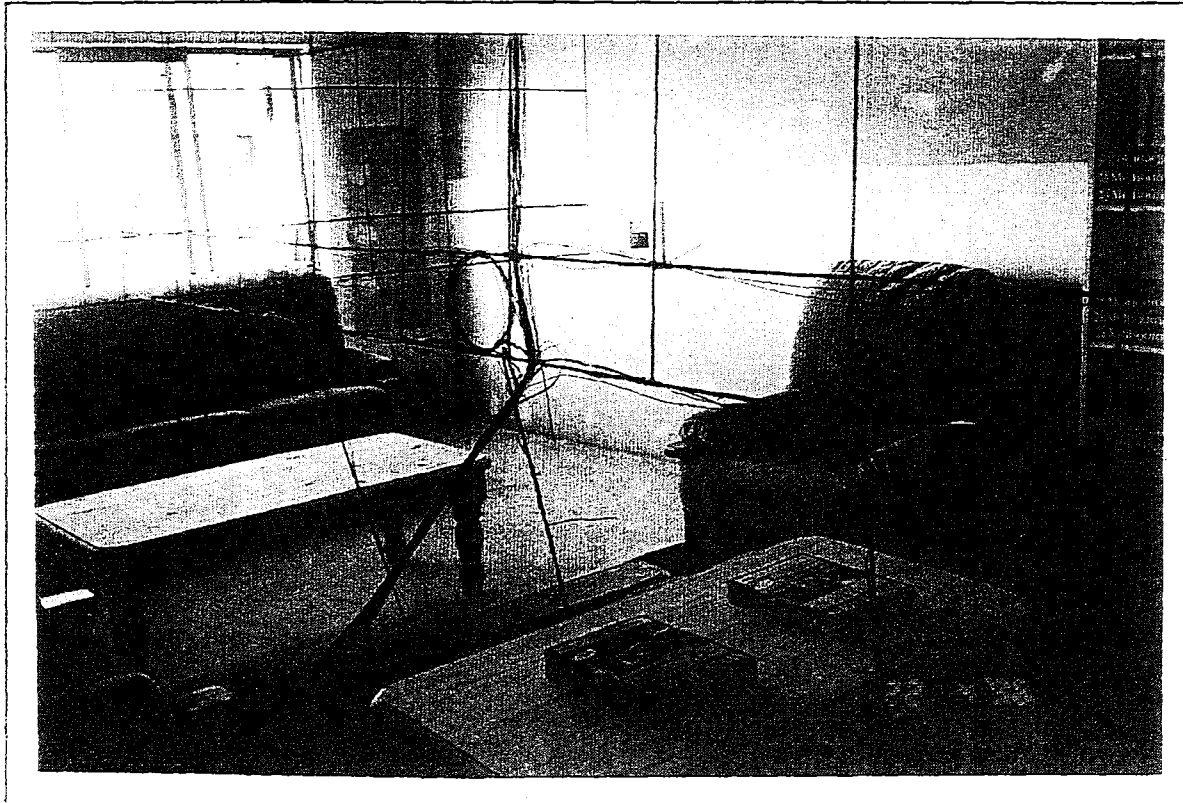

**Figure 15: Fuel Load Layout in the south-west side of the Burn Room**

In Level 1 corridor a piece of polyurethane (0.56 x 0.56 x 0.1 m) was placed on the seat of a steel frame mock-up chair. This was located 1.85 m away from the west edge of the burn room door frame in the center of the corridor. Five pieces of carpet and underlay (1.0 m x 1.0 m) were also located in Level 1 corridor. This carpet and underlay was located at 3.0 m intervals along the length of the corridor, with one piece located directly outside the burn room door (ie: there was 2.0m between each piece of carpet). These items were used as indicators of the conditions in the corridor, not as additional fuel load.

All fuel load items and indicators were conditioned prior to testing for a minimum of 7 days at a temperature of 20 °C.

## ***4.2 Ignition Source***

The source of the ignition for all the fire tests was a standard wooden crib weighing 150g, using 200 mm x 3.5 mm sticks. This was placed on the center seat of the 3 seater couch on the small platform as shown in Figures 12 & 16.

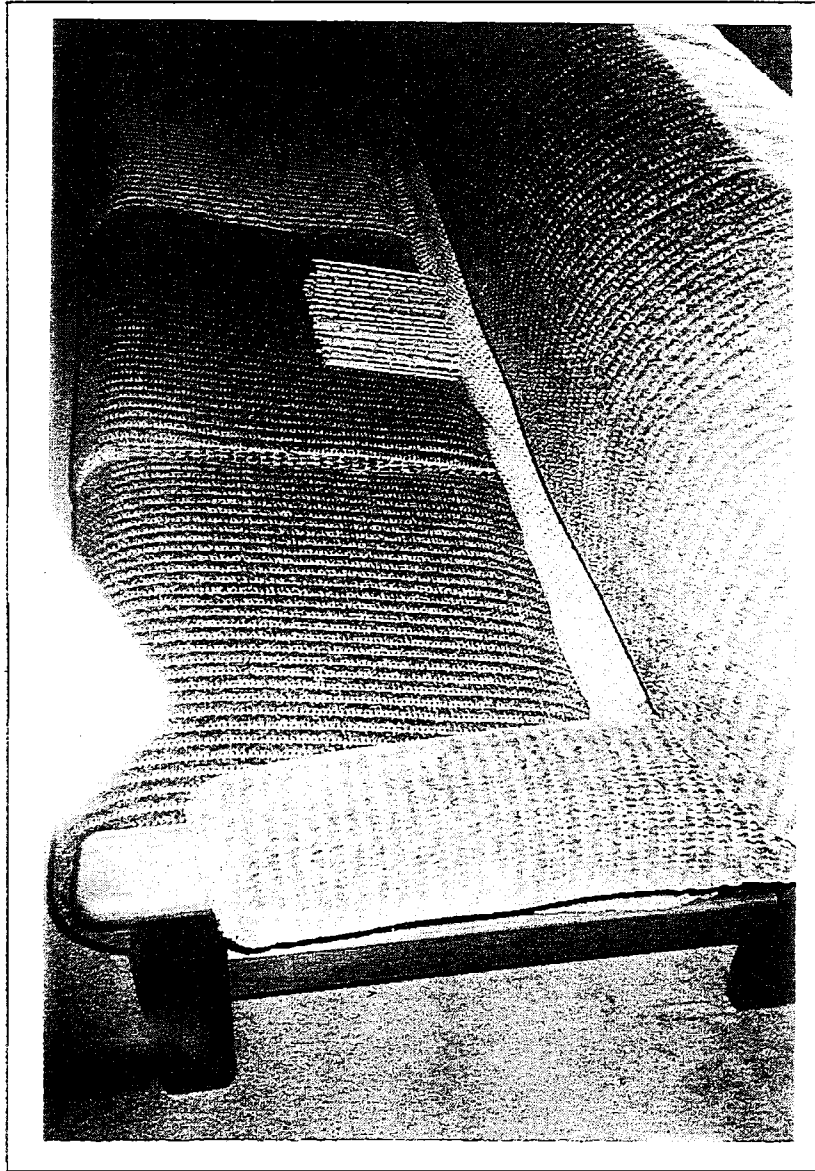

**Figure 16: Ignition Point on the three seater couch**

### 4.3 Window Lowering Criteria

During the course of fire development it was likely that the window would break and dislodge, significantly altering ventilation conditions within the burn room. In order to eliminate variations in glass behaviour between experiments it was decided that the window should be lowered when certain criteria had been exceeded. The first criterion was to lower the entire window when the thermocouple mounted to the inside surface of the windows glass indicated a temperature of 250°C. The second criterion was to lower the entire window if the fire self- extinguished as evidenced by a mass loss rate of less than 0.1 kg/min. This was done to see whether the fire would proceed to flashover. These criteria are discussed in further detail in Appendix 4. The tests were conducted on days when the external wind conditions were less than 10 km/hr to ensure minimal disturbance once the window was lowered.

### 4.4 Test Schedule

The test schedule is shown below and the test conditions are shown in Table 4

- Test 1            Burn Room Door Open (D1), Stairwell Door Closed (D9) [Test No. FO1]
- Test 2            Burn Room Door Closed (D1), Stairwell Door Closed [Test No. FO2]
- Test 3            Burn Room Door Closed (D1) [Test No. FO3] - (Repeat of Test 2)
- Test 4            Burn Room Door Open (D1), Stairwell Door Open [Test No. FO4]
- Test 5            As Test 4 but with Air Handling on -[Test No. FO5]
- Test 6            As Test 3 but with Air Handling on -[Test No. FO6]
- Test 7            As Test 1 but with Combustible Wall lining in Level 1 Corridor [Test No. FO7]
- Test 8            As Test 4 but with Sprinkler charged -[Test No. FO8]

Table 4: Conditions for Fire Tests

Test ID	Burn Room Door (D1) into corridor	Stairwell Door (D9) Level 1	Sprinklers Charged	Stair Pressurisation & Smoke Management System
FO1	Open	Closed	No	No
FO2	Closed	Closed	No	No
FO3	Closed	Closed	No	No
FO4	Open	Open	No	No
FO5	Open	Open	No	Yes
FO6	Closed	Closed	No	Yes
FO7	Open	Open	No	No
FO8	Open	Open	Yes	No



The stairwell doors on Level 1M and 2 remained closed while the stairwell door on Level 3 remained open for all the fire tests. All doors in the corridors of Levels 1M, 2 and 3 remained closed except for the door to Room 201 which remained open for the duration of every experiment. The lift also remained closed during every test.

#### 4.5 Combustible Lining Specifications

In the case where combustible lining is specified to be along Level 1 corridor walls, (FO7), 4 mm 3 ply Luan panel board (2 outer laminates of Maranti and an inner core of pine) was used. The lining covered the wall from the ceiling to the floor and was located in the position shown in Figure 17.

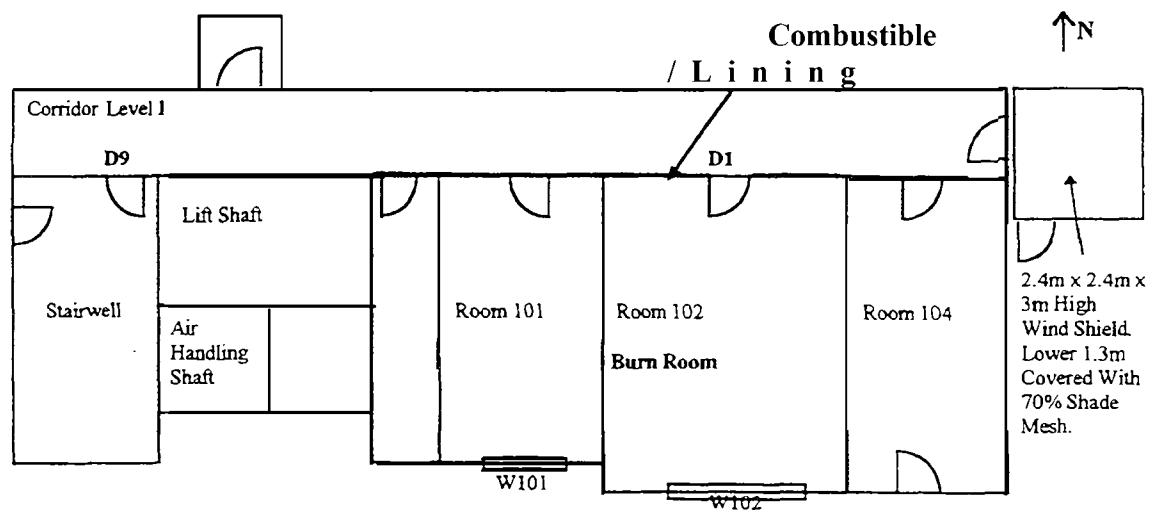

Figure 17: Combustible lining location in Level 1 corridor

## 5. INSTRUMENTATION

### *5.1 Data Logging System*

The data acquisition hardware consisted of twelve low level multiplexers and two high level multiplexers which were linked to a hardware data acquisition card. This data acquisition card was driven by the data acquisition package Labtech Notebook version 8.02. This data was directly stored on the hard disk in binary format with a time stamp relative to the sample time. This stored binary data was then converted into the appropriate physical quantities at the end of the test. The data logging and processing system is discussed in greater detail in Appendix A of reference 1.

### *5.2 Heat Flux Transducers*

Total heat flux transducers were used to measure the total heat transfer during the experimental program. A sapphire window was placed on a number of the total heat flux transducers and were used to measure the radiative heat transfer, (note: the sapphire window cuts out convection). The heat flux transducers were of the Gardon Gauge type and used water to cool the heat sink during fire tests. These heat flux transducers have ranges varying from  $113 \text{ kW/m}^2$  to  $227 \text{ kW/m}^2$  and an accuracy of  $\pm 3 \%$  of this full range.

### *5.3 Mass Load Platforms*

All the fuel load was distributed between the two mass platforms in the burn room, except for along a long strip of carpet and underlay in the center of the burn room 150 mm wide. These two platforms were custom built to measure the mass loss throughout the experiments, and comprise of a platform suspended by load transfer rods. The area of these two mass platforms are approximately  $3.6 \text{ m} \times 2.6 \text{ m}$  &  $2.6 \text{ m} \times 2.4 \text{ m}$  and the maximum mass each can carry is 600 kg and 125 kg respectively. Each platform is covered by compressed cement sheets and is supported by three load cells. These load cells are located on Level 1M above the burn room. The load is transferred from the platforms to the cells via 8 mm stainless steel rods. This was done to ensure the load cells were not exposed to high temperatures and other fluctuating conditions, and to ensure repeatability. The mass platforms are checked before each test and were calibrated at the beginning of the test series. The small and large platforms have a resolution of 30 g and 146 g respectively

#### ***5.4 Smoke/Heat Detectors & Smoke Densitometers***

Two types of smoke detectors were used; ionisation and photo-optical. The third detector used was of a thermal type. The detectors used during this experimental program are commercially available and comply with Australian Standard 3786-1993. Normal sensitivity ionisation detectors were used in the experiments except those within the return air duct which were of a high sensitivity. All the photo-optical detectors were of a high sensitivity.

Optical density was measured using infra red densitometer equipment. These units are from the Aeronautical and Maritime Research Laboratories.

#### ***5.5 Thermocouples***

Fiberglass-fiberglass K-type thermocouples and metal insulated and metal sheathed (MIMS) type thermocouples were used throughout the experiments. Most of the thermocouples were mounted on racks constructed of 6 mm stainless steel tubing which provided a grid for temperature measurement and distribution. All thermocouples used in this program were purchased with calibration certificates.

#### ***5.6 Chemical Analysers***

Chemical compositions measured were O<sub>2</sub>, CO<sub>2</sub> and CO. These were measured using a custom-built gas analysis unit via 6 mm stainless steel tube probes placed at various locations. These custom built analysers were manufactured and supplied by Anri instruments and Airmet. The temperature of the gases sampled were reduced by the use of custom built heat exchangers which were attached to silica-gel moisture filters before being passed through the analysing unit. The time lag associated with the response time of the gas analysers has been taken into account in the presented data. The maximum range of the CO<sub>2</sub> is 0-10% for the Anri units and 0-5% by volume for the Airmet units. The maximum range of the CO is 0-5% and 0-2% by volume for the Anri units and 0-0.1% for the Airmet units.

## ***5.7 Video and Photographic Recording***

Video recording equipment was used to record the fires as well as photographs. Generally there were 7 cameras;

- looking into burn room through a panel of Boro-silicate glass from room 101 to observe ignition (Panasonic-SVHS)
- looking into burn room through a panel of Boro-silicate glass from room 104 to observe the mechanisms of spread from the small platform to the large platform (Hitachi- Video 8)
- looking into burn room door across the corridor through a panel of Boro-silicate glass (Hitachi- Video 8)
- within corridor of level 3 looking down the corridor (Hitachi- Video 8)
- looking into burn room window from outside (Panasonic-SVHS)
- one camera on either side of the burn room window to view both sides of plume (Hitachi- Video 8)

## ***5.8 Ambient Weather Monitor***

Ambient weather conditions were measured before, during and after the tests using a Weather Monitor II weather station. The data, measured at 5 minute intervals, included temperature, wind speed and direction, humidity, pressure and rainfall. These variables were measured approximately 17 m south of external face of the burn room window at a height of 5 m above the ground.

## 6.0 LOCATION OF INSTRUMENTATION

The type and location of instruments is specified for each room in the following section. This has varied slightly over the initial proposal as new instrumentation has arrived or requirements for instrumentation have changed.

### 6.1 Burn Room

There are two thermocouple racks located within the burn room, one in the north-south direction and the other in the east-west direction. There are 35 thermocouples distributed on each on these racks, which were mounted 250 mm from the ceiling. The configuration is shown in Figures 18 and 19 and the location of the racks in the burn room is shown in Figure 21.

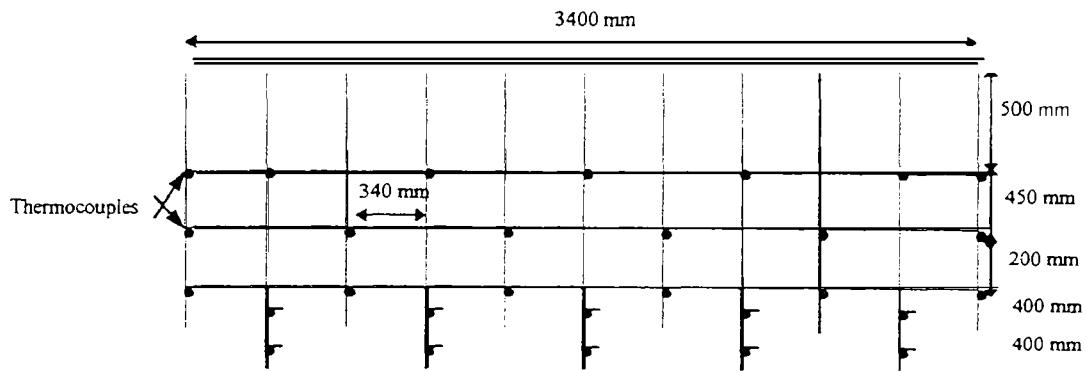

Figure 18: East-West thermocouple rack in burn room (Total 35 thermocouples)

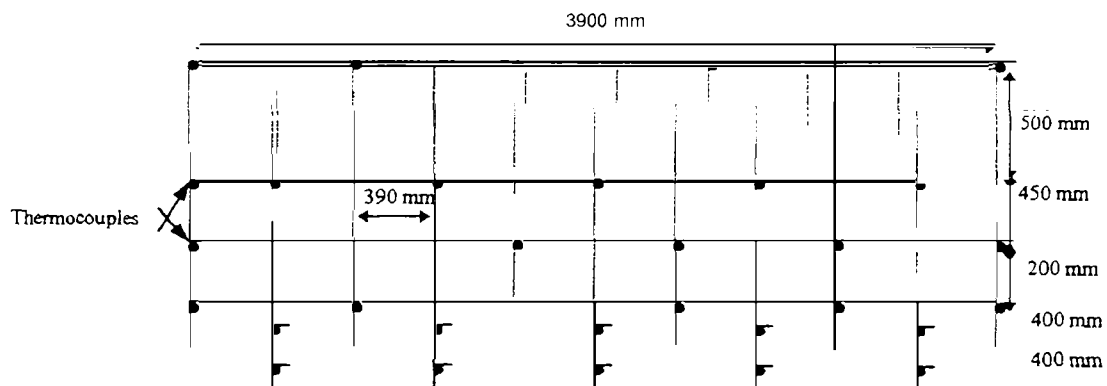

Figure 19: North-South thermocouple rack in burn room

Located together in the center of the burn room are an ionisation type smoke detector, a photo-optical type smoke detector and a thermal detector. A thermocouple was also located adjacent to these detectors.

A fast response thermocouple was placed on the glass bulb and adjacent to both of the two sprinkler heads in the burn room. These thermocouples were used to record activation time. The sprinkler water supply was only charged with water for Test FO8.

There were two gas species sample tubes, measuring O<sub>2</sub>, in the burn room; 1 above the small mass loss platform and 1 in the center of the room at heights of 1.9 m.

The instrumentation in the center line of the burn room door when it was open was:

- 8 O<sub>2</sub> sensors
- 6 CO<sub>2</sub> sensors
- 6 CO sensors
- 8 Thermocouples
- 8 Velocity Probes ( McCaffrey cups)

The instrumentation at the door was spaced at 250 mm intervals from the top of the door. The thermocouple tree in the door is shown in Figure 20. The CO & CO<sub>2</sub> sensors are located at the same positions as the O<sub>2</sub> sensors minus the bottom two sensors.

A heat flux transducer was placed 700 mm from the west wall and 2450 mm from the south wall in the floor for all tests after and including Test FO2.

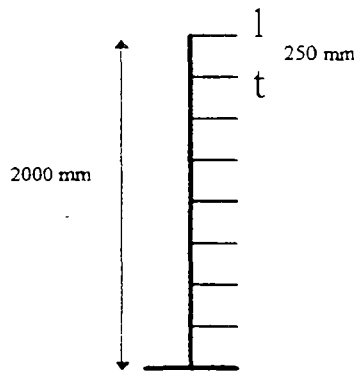

**Figure 20: Thermocouple Tree in Burn Room Door**

### **6.1.1 Return Air Duct**

Located together 1.2 m down the return air duct, on the top center, are an ionisation type smoke detector, and a photo-optical type smoke detector. Both these detectors are of high sensitivity. The photo-optical detector in the return air duct activates the smoke management and the stair pressurisation sub systems.

### **6.1.2 Timber and Steel Stud Plaster Board Wall**

This wall was instrumented only for closed door experiments. One heat flux transducer (capable of measuring up to 230 kW/m<sup>2</sup>) and one thermocouple was placed in the center of the timber section of the wall at a height of 1600 mm next to each other.

In one of the noggings in the wooden section there were 12 thermocouples. Within the cavity of the timber section 12 thermocouples were lined down the center. A similar setup of thermocouples was made within the cavity of the steel stud section also using 12 thermocouples.

## ***6.2 Corridor Outside Burn Room (Level 1)***

Along the length of Level 1 corridor there were 10 thermocouple trees 2.0 m high spaced at 1.39 m intervals, (Figure 21). Four thermocouples were attached to these trees at 500 mm intervals, with the exception of the one in the center of the corridor which has 9 thermocouples placed on it at 250 mm and has a total height of 2250 mm.

The instrumentation in the center line of Level 1 stairwell door is:

- 1 O<sub>2</sub> sensor at 1.7 m high
- 1 CO<sub>2</sub> sensor at 1.7 m high
- 1 CO sensor at 1.7 m high
- 7 Velocity Probes (McCaffrey cups), (evenly spaced 204 mm from the top of the door)
- 1 Vertical Rack of 10 Thermocouples (evenly spaced 204 mm from the top of the door)

Located together in the center of the corridor outside Room 101 are an ionisation type smoke detector, a photo-optical type smoke detector and a thermal detector. A thermocouple, a densitometer and a velocity probe, which was placed co-axially along the corridor, are located adjacent to these detectors. The velocity probe and the densitometer were added for all tests other than FO1 and FO8.

The sprinkler in the center of the corridor has one thermocouple attached to the bulb and one thermocouple located adjacent to it. This sprinkler was wired to record activation time but was not charged, acting as an indicator rather than a suppression mechanism except in Test FO8 when the system was charged with water.

Also located in level 1, adjacent to the slab of polyurethane was a heat flux transducer with a sapphire window. This heat flux was placed at the same height as the top of polyurethane foam surface.

## ***6.3 Level 1, IM, 2 and 3 Stairwells***

Two thermocouples were located in the stair shaft at each level. One thermocouple was on the north side and the other was on the south side of each landing at a height of 1.7 m. Adjacent to these there was a densitometer and a pressure transducer also at a height of 1.7 m.

The layout of the instrumentation on is shown in Figures 21 - 25.

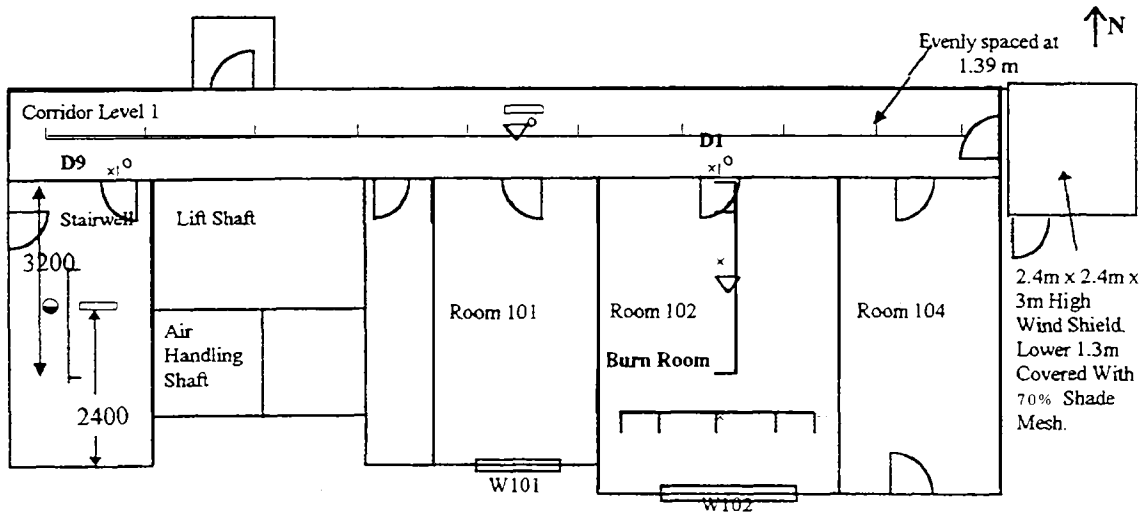

- Key
- ⊥ Thermocouple
  - x Species sample point
  - Pressure transducer
  - Smoke densitometer
  - McCaffrey cup
  - ▽ Smoke detectors

Figure 21: Instrumentation layout on Level 1.

## 6.4 Levels 1M and 2

The following instrumentation was the same for Levels 1M and 2;

The instrumentation in the center line of Level 1M and 2 stairwell doors in the stairwell is:

- 1 O<sub>2</sub> sensor at 1.7 m high
- 1 CO<sub>2</sub> sensor at 1.7 m high
- 1 CO sensor at 1.7 m high
- 1 Vertical Rack of 10 Thermocouples (evenly spaced 204 mm from the top of the door)

Ten thermocouples were spaced evenly at 1.39 m intervals down the length of the corridors at a height of 1.7 m.

In addition to this instrumentation, 2 thermocouples were placed in Room 201 at a height of 1.7 m.

The instrumentation on Levels 1M and 2 is shown in Figures 22 and 23 respectively.



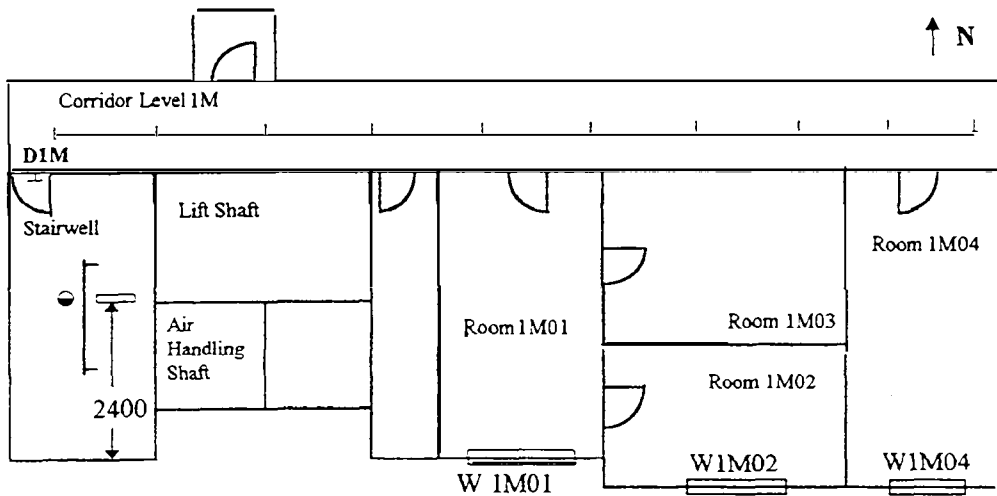

Figure 22: Instrumentation layout on Level 1M.

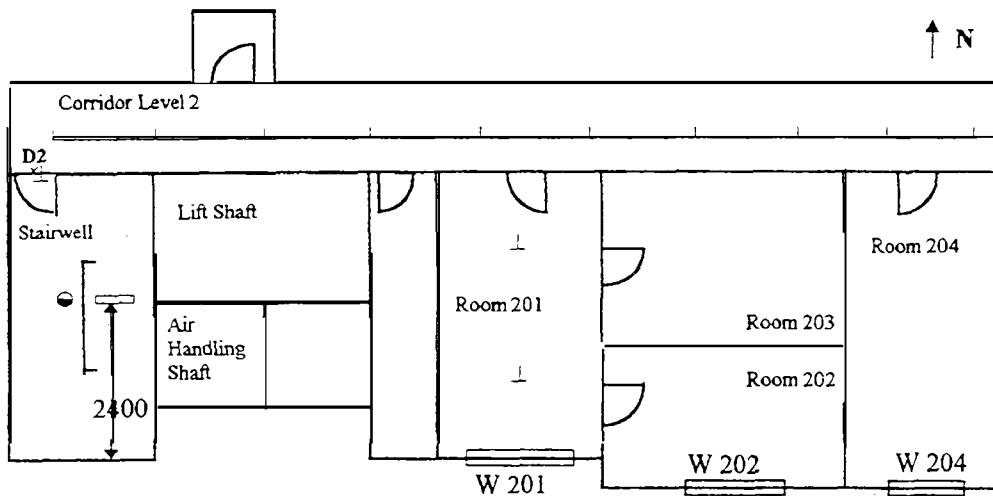

Figure 23: Instrumentation layout on Level 2.

### 6.5 Level 3

The instrumentation in the center line of Level 3 stairwell door is:

- 1 O<sub>2</sub> sensor at 1.7 m high
- 1 CO<sub>2</sub> sensor at 1.7 m high
- 1 CO sensor at 1.7 m high
- 1 Vertical Rack of 10 Thermocouples (evenly spaced 204 mm from the top of the door)

Located along center of the corridor at the east end and at the center are a set of gas analysers consisting of  $O_2$ ,  $CO_2$ , and  $CO$  sensors. Two densitometers are also located along the center line of the corridor adjacent to these gas analysers.

Ten thermocouples were spaced evenly at 1.39 m intervals down the length of the corridors at a height of 1.7 m., with the exception of the one in the center of the corridor which is a thermocouple tree with 9 thermocouples attached to it at 250 mm intervals and has a total height of 2250 mm.

The instrumentation on Level 3 is shown in Figure 24.

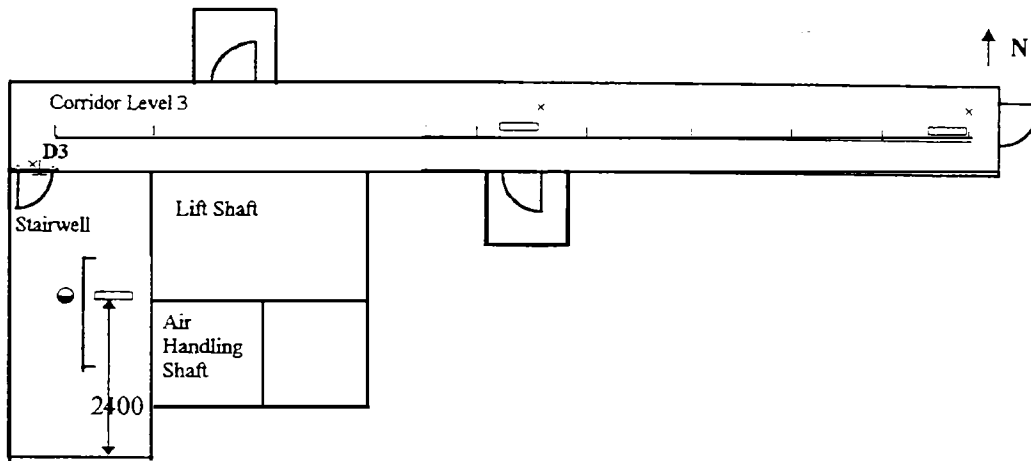

Figure 24: Instrumentation layout on Level 3.

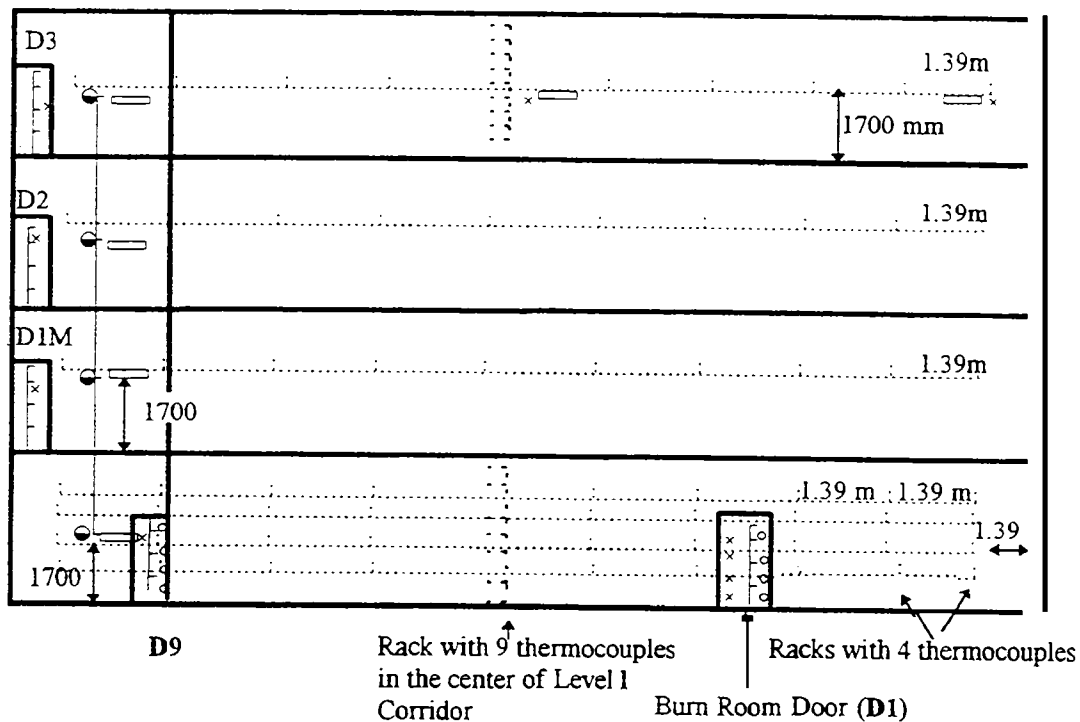

Figure 25: Elevation of the instrumentation layout.

## 6.6 External Instrumentation

The instrumentation on the facade of the building directly above the window consists of 5 heat flux transducers and a 3-D thermocouple rack. This 3-D grid is mounted to the external facade of the building just above the burn room window. There are 140 thermocouples points on this grid as shown in Figure 27. The location and dimensions of the external instrumentation are shown in Figure 26.

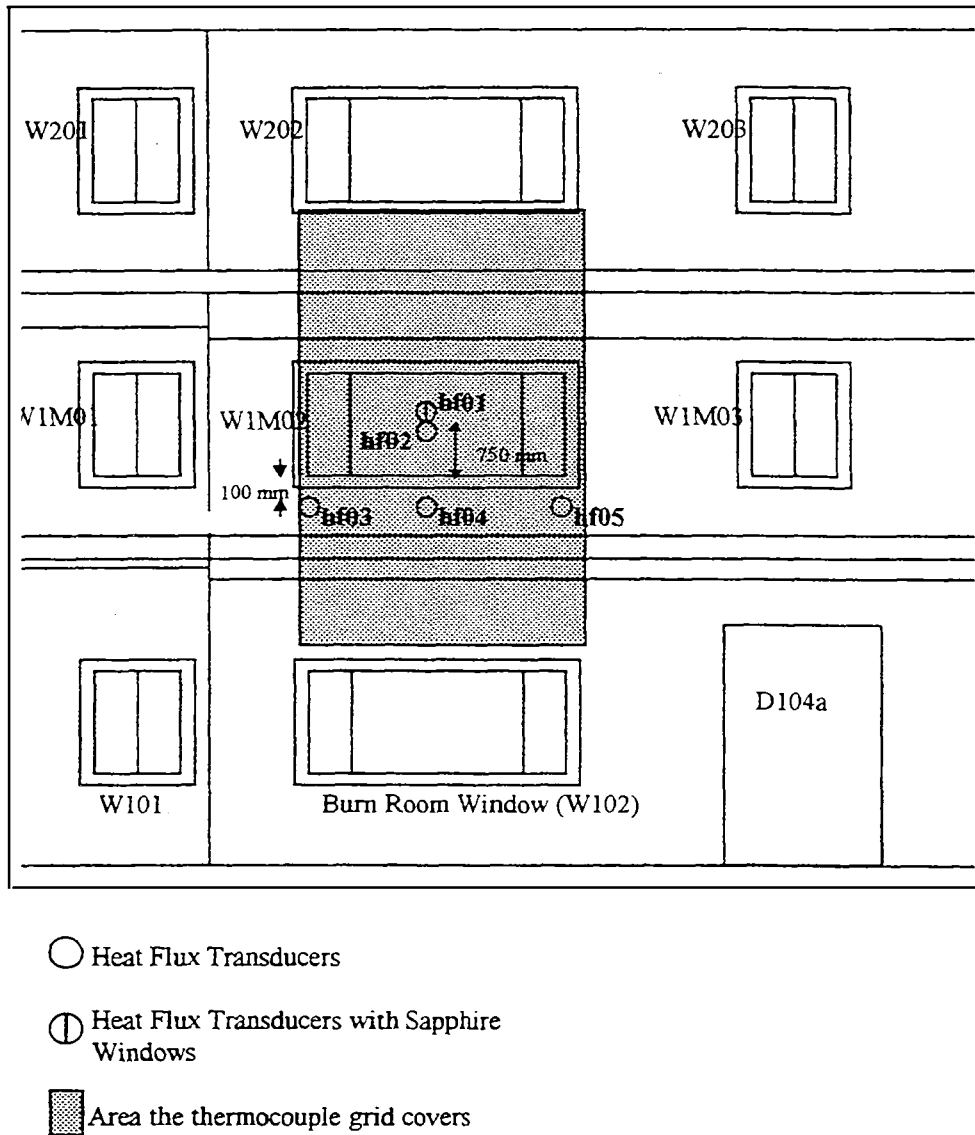
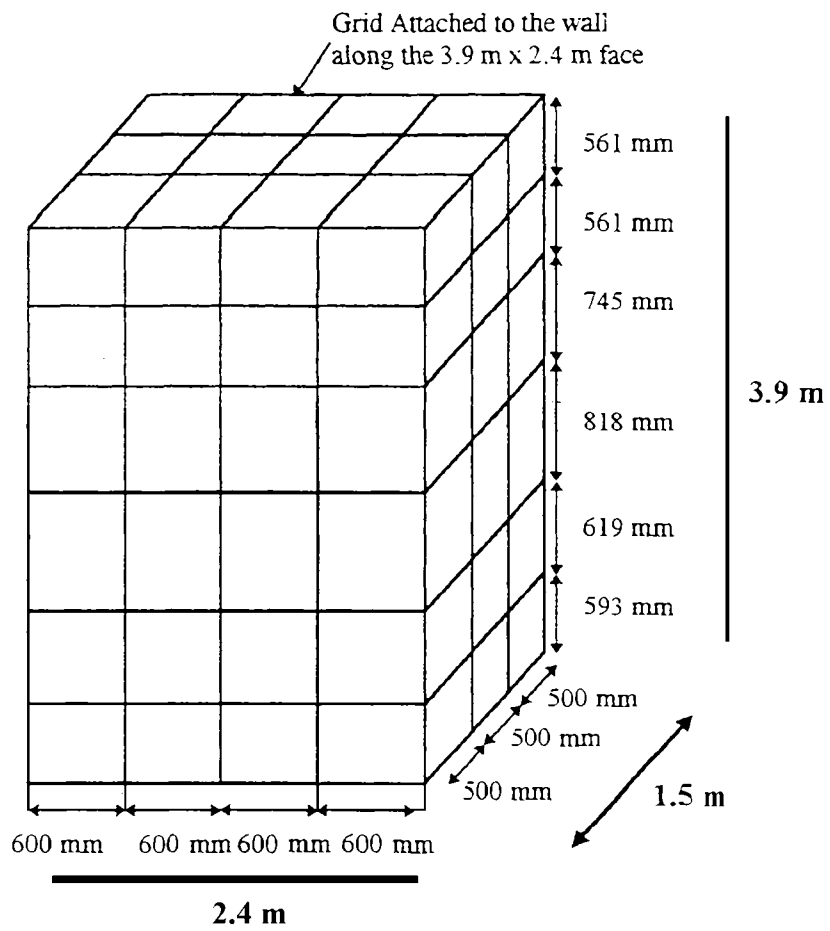

Figure 26: Instrumentation on the external facade (south side) of building



**Figure 27: Thermocouple grid on the south wall of building (note: thermocouples attached to each grid point intersection, 140 thermocouples in total)**

## 7. General Pictorial Guide to the Fire Tests

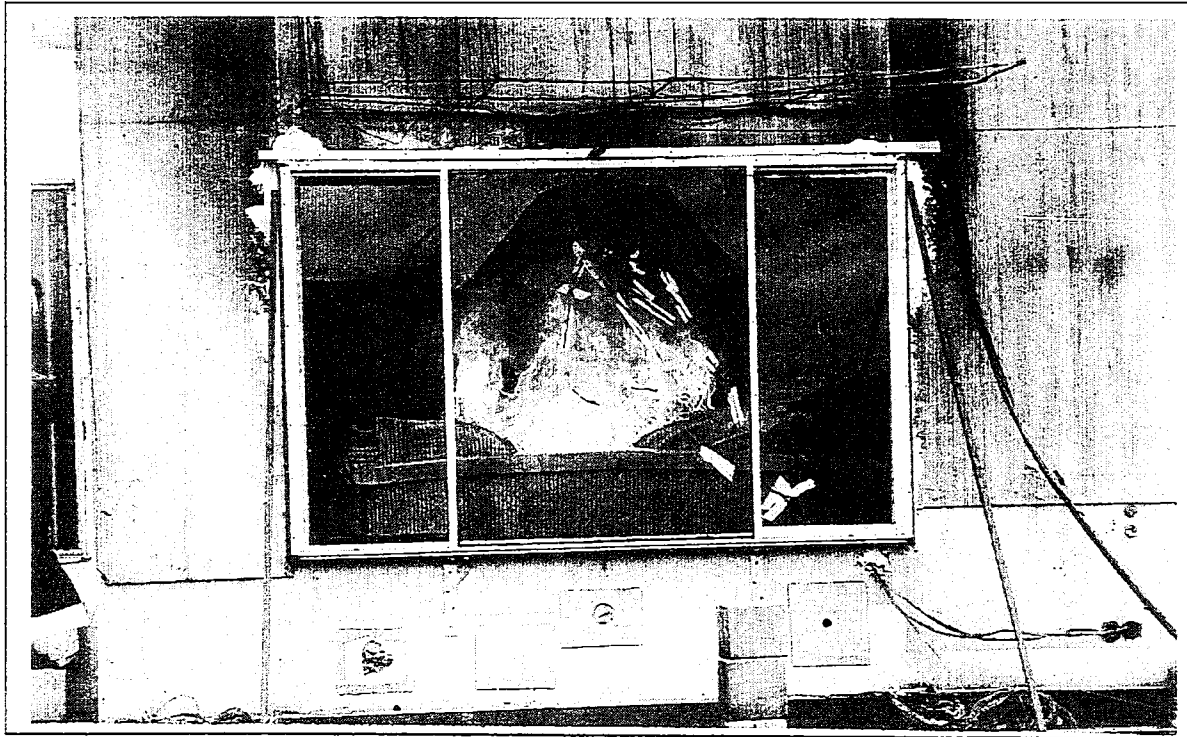

Figure 28: Initial stage of fire

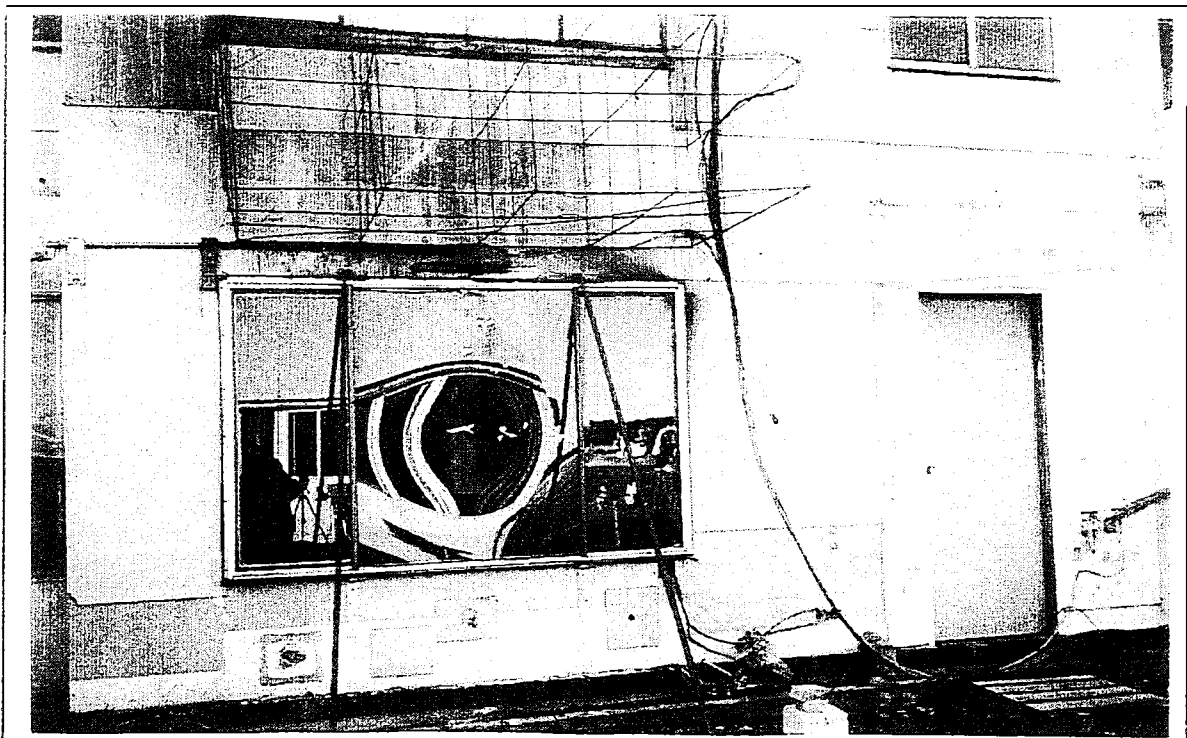
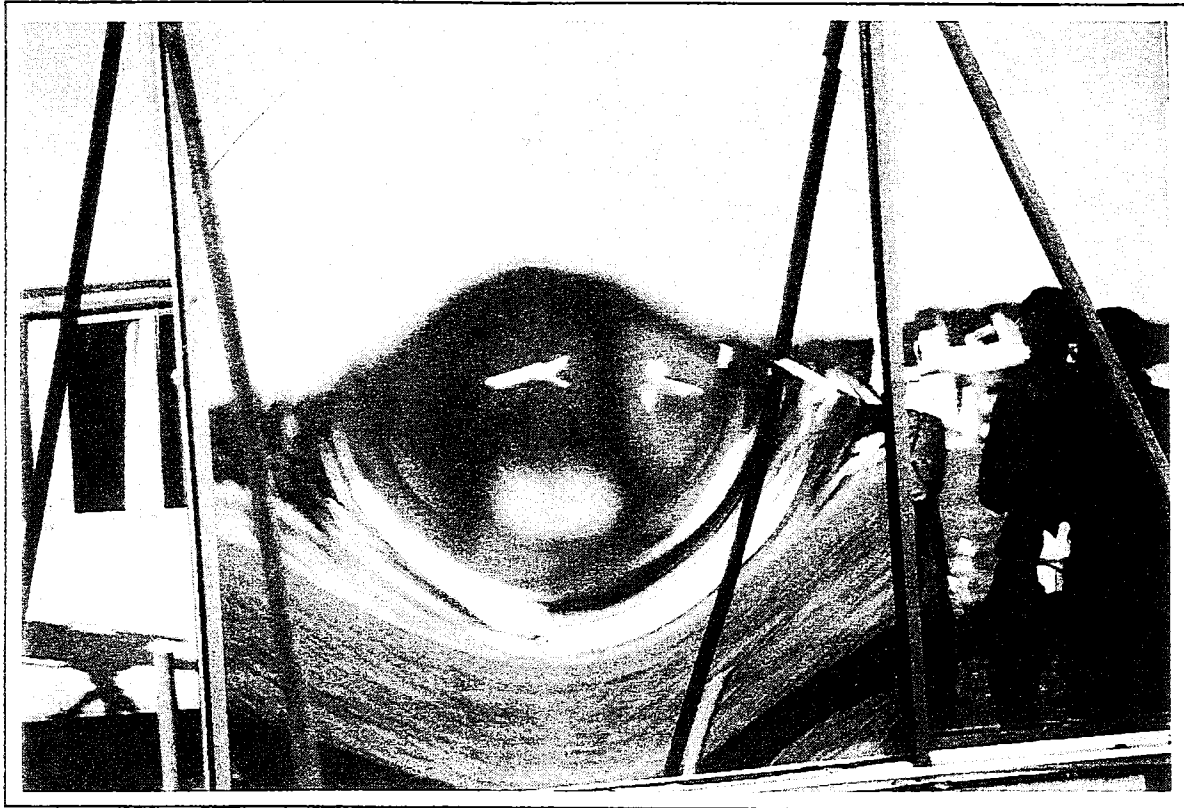
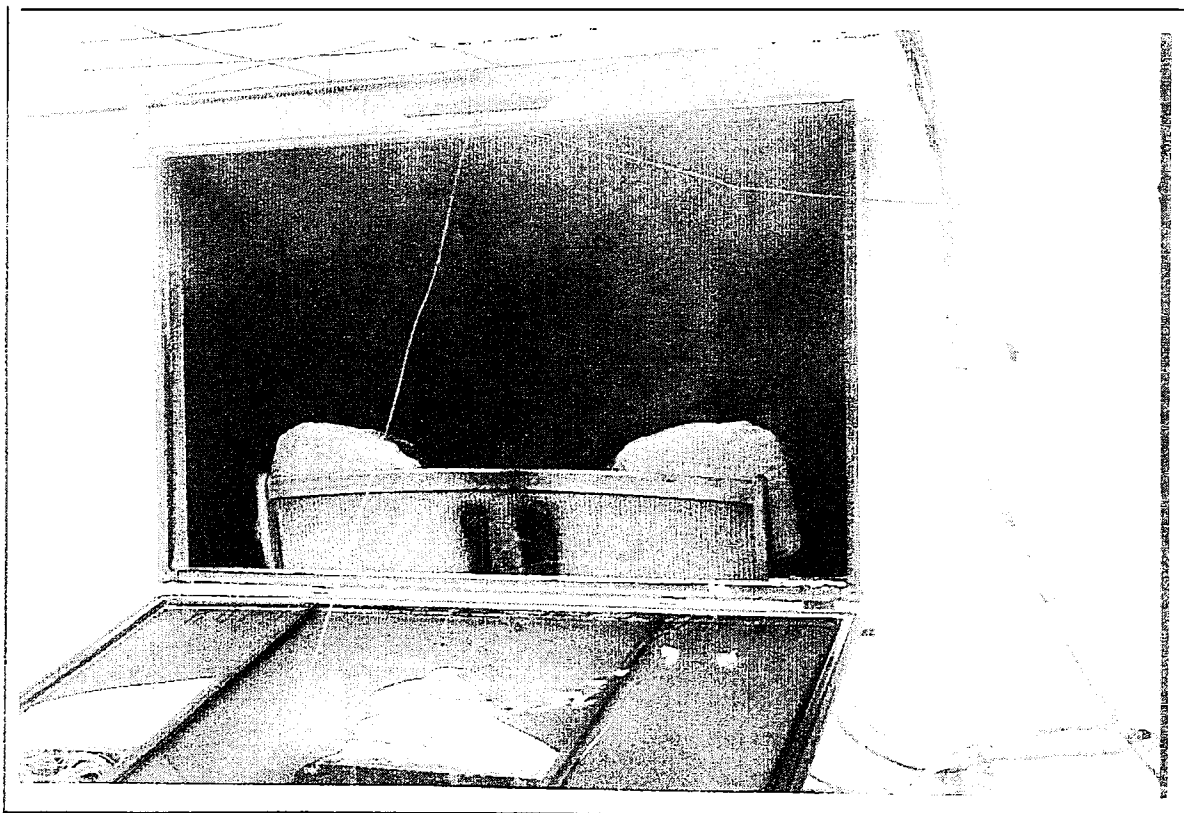

Figure 29: Initial bowing of the middle pane of the burn room window



**Figure 30: Severe bowing of the burn room window**



**Figure 31: Window is lowered**

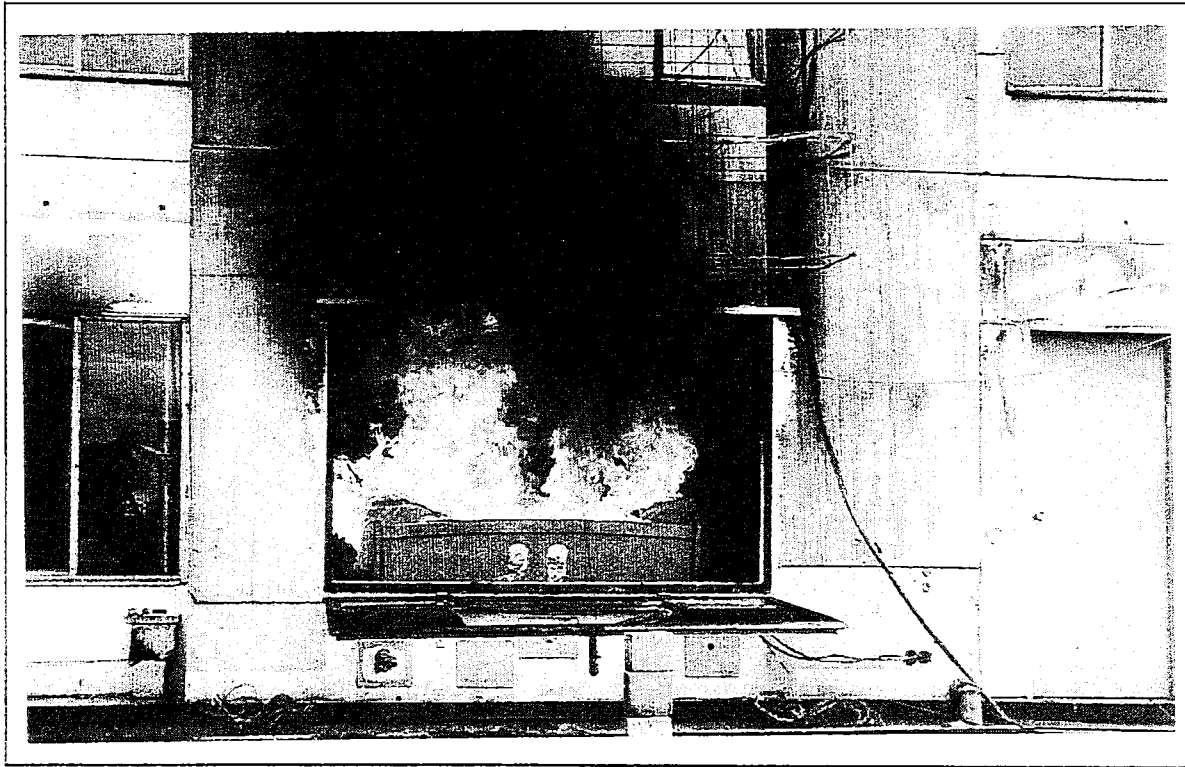

Figure 32: Approximately 2 minutes after barn room window lowered

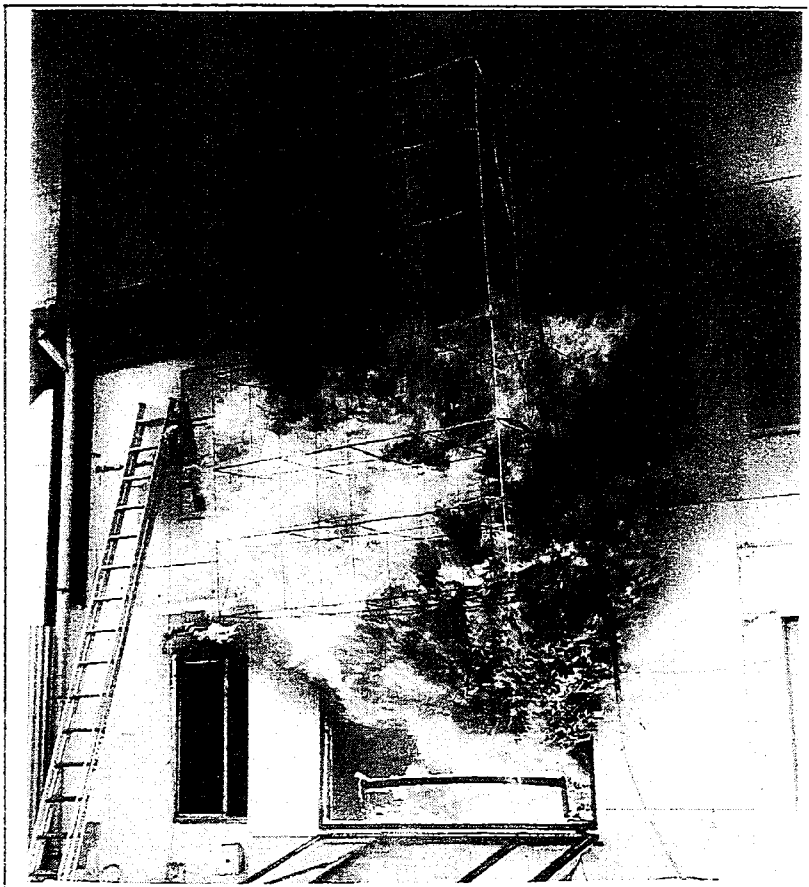

Figure 33: Flashover (View 1)

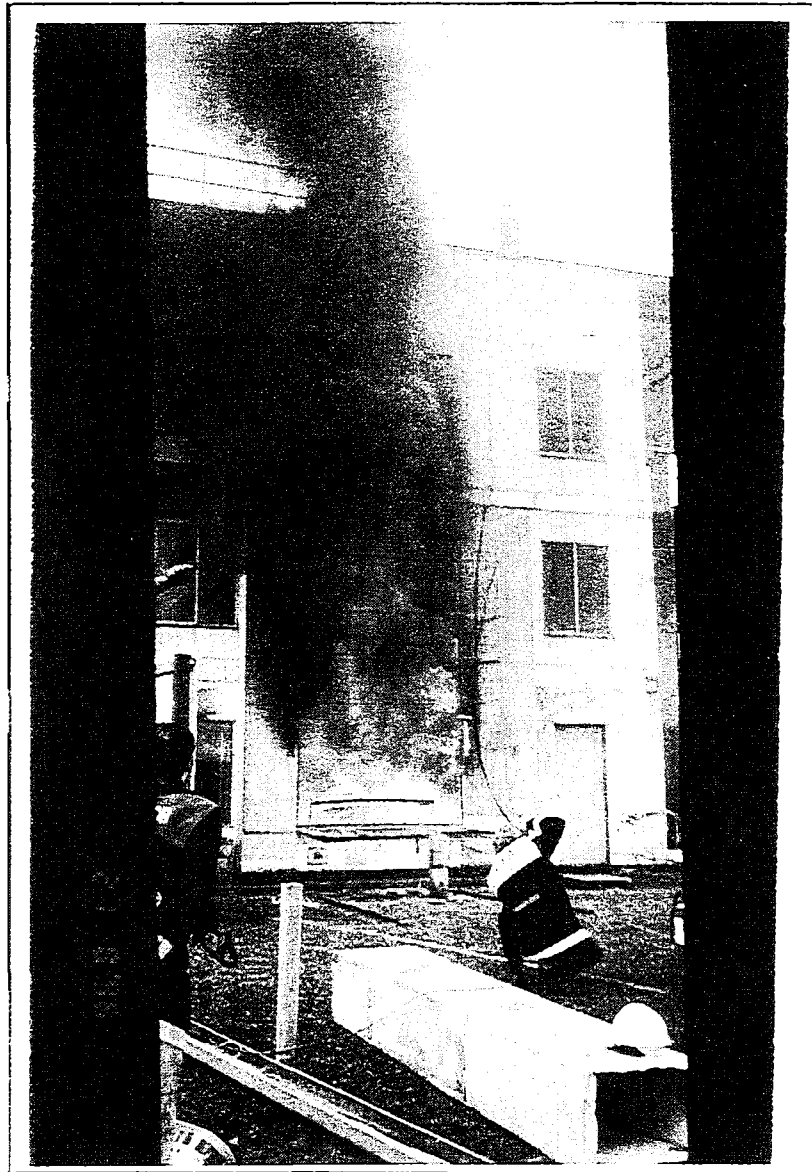

Figure 34: Flashover (View 2)



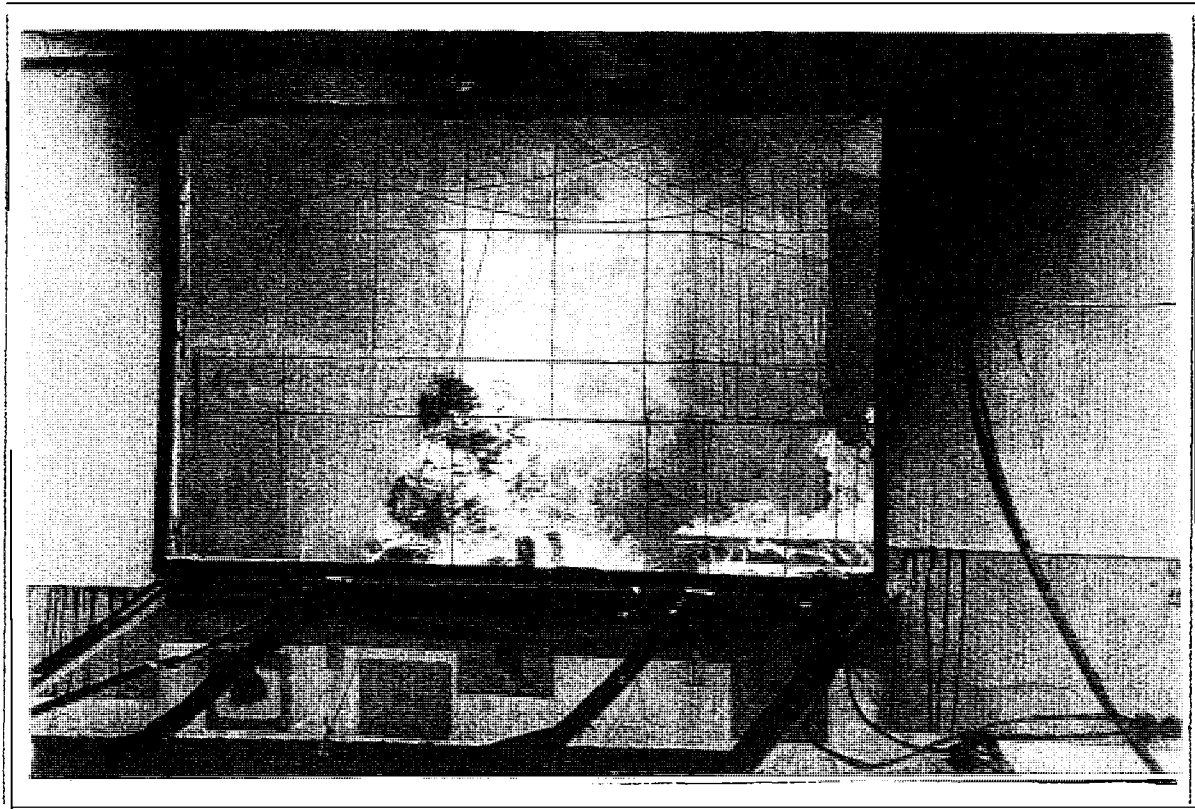

Figure 35: Decay (View 1)

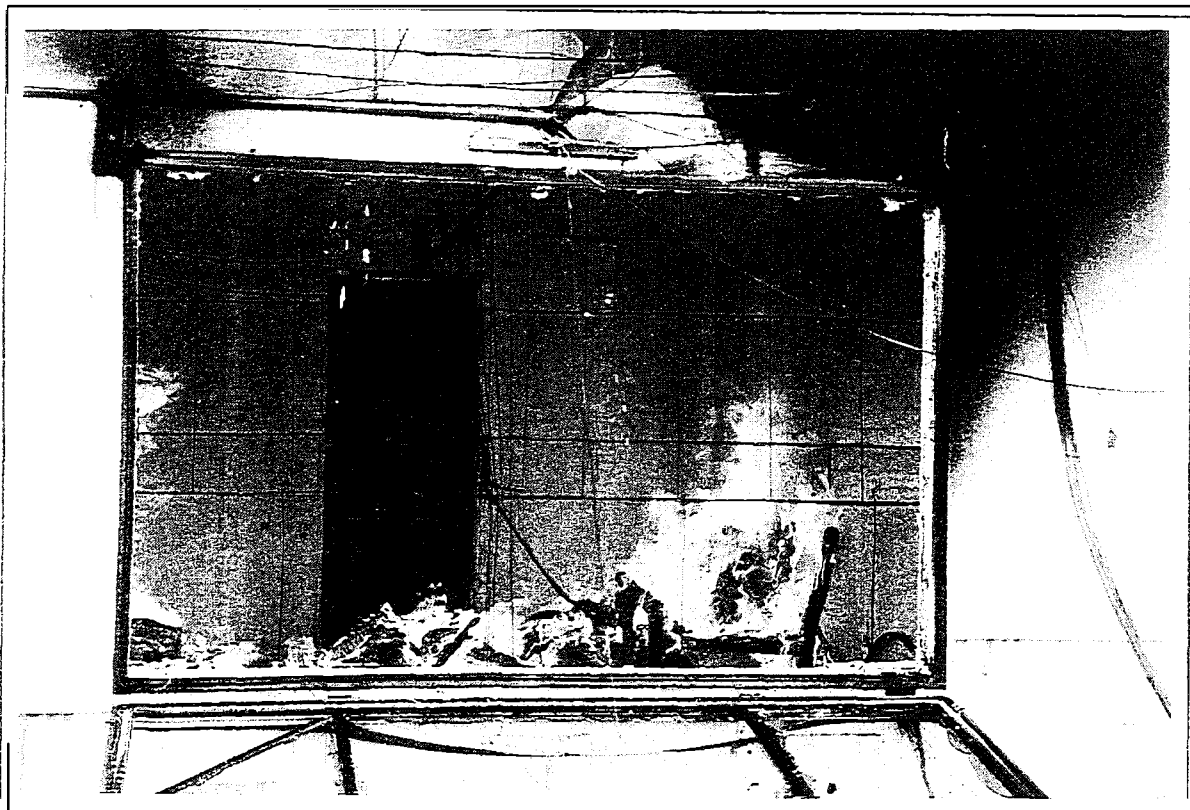

Figure 36: Decay (View 2)

## 8. GRAPH DESCRIPTIONS

### 8.1. General

For each experiment a number of graphs have been plotted; either as 3-D surface plots or 2-D line plots. The variable being measured is always located on the vertical axis. The software packages used for graphed were “Origin” for the 2D plots and “Excel” for the 3D plots. Where possible the same graphs have been represented for each fire test and the scales have been adjusted so direct comparisons can be made. There are three sets of scales for the y-axis (2-D) and z-axis (3-D); one for the bum room door closed scenario, one for the bum room door open scenario and one for the sprinkler test. The time axis (x-axis) is the same where possible.

Note: The x in Figure FOx-1 represents 1 to 8 as denoted by the fire test

### 8.2 Mass Loss

The mass loss recorded on each of the platforms was added to give a total mass loss (kg) in the bum room Figure FOx-1. This mass loss was then used to produce the rate of mass loss (kg/s) at any given time (by taking the derivative). The heat release rate in MW was then calculated by multiplying the effective heat of combustion by the mass loss rate (Figure FOx-2). The calculation for effective heat of combustion is shown in Appendix 5.

### 8.3 Average, Maximum and Minimum Burn Room Temperature

The average bum room temperature (°C) was obtained by taking the unweighted spatial average of all the thermocouples in the bum room.

The maximum room temperature trace shown in Figure FOx-3 was measured from a thermocouple in the bum room, which registered the *highest peak temperature*. A similar description applies to the minimum room temperature trace.

### 8.4 Heat Flux

The heat flux in the center of the bum room floor measures total heat flux in kW/m<sup>2</sup>. The heat flux transducer in the corridor next to the slab of polyurethane measures only radiative heat flux as it is covered by a sapphire window. The external heat flux transducers measure total heat flux unless specified otherwise.

The full range of the heat flux transducer in Figure FOx-5 is 227 kW/m<sup>2</sup>. The full range of heat flux transducers hf0 1, hf02, hf03, hf04, hf05 (Figure FOx-36) are 56 kW/m<sup>2</sup>, 113 kW/m<sup>2</sup>, 113 kW/m<sup>2</sup>, 113 kW/m<sup>2</sup> and 113 kW/m<sup>2</sup> respectively.

## 8.5 Gas Species Concentrations at various locations

The gas species measured were O<sub>2</sub>, CO<sub>2</sub> and CO. The time lag associated with the response of the gas analysis units (T<sub>50</sub> times) have been accounted for in the graphs. In some cases the species concentrations present exceeded the upper limit (maximum range) of the gas analysers, specified in Tables 5 and 6, and the instruments became saturated. This is indicated by the occurrence of a plateau in the line plot or surface plots of the species concentrations. In some cases the equipment has recorded values above the specified manufacturers calibrated range; this data is presented but should be viewed with this in mind. The gas species concentrations are measured in Vol (%), which is related to ppm by a ratio of 1 %=10,000 ppm.

**Table 5: Maximum Calibrated Range for Carbon Monoxide Analysers**

<b>Figure FOx-6 (CO)</b>	
Height above the floor (mm)	Maximum calibrated range Vol (%)
2000	5%
1750	5%
1500	5%
1250	2%
1000	2%
<b>Figure Fox-19 (CO)</b>	
Level 1 Stairwell door	2%
Level 1M Stairwell door	2%
Level 2 Stairwell door	2%
Level 3 Stairwell door	0.1%
Level 3 Corridor (center)	0.1%
Level 3 Corridor (east end)	0.1%

**Table 6: Maximum Calibrated Range for Carbon Dioxide Analysers**

<b>Figure FOx-7 (CO<sub>2</sub>)</b>	
Height above the floor (mm)	Maximum calibrated range Vol (%)
ALL	10%
<b>Figure FOx-18 (CO<sub>2</sub>)</b>	
Level 1 Stairwell door	10%
Level 1M Stairwell door	10%
Level 2 Stairwell door	10%
Level 3 Stairwell door	5%
Level 3 Corridor (center)	5%
Level 3 Corridor (east end)	5%

## 8.6 Flow Velocity

The flow velocity (m/s) was measured with McCaffrey cups. As the McCaffrey cups are calibrated at an ambient temperature, the velocities have been adjusted against recorded temperatures adjacent to the McCaffrey cups to give the correct flow measurements.

A positive velocity indicates movement towards the fire (ie- towards or into the bum room) and a negative velocity indicates flow is moving away from the bum room.

## 8.7 Differential Pressure

The difference in pressure was measured at each level in the stairwell. The high pressure side was located in the stairwell shaft and the low pressure side was located in the lift shaft, as the lift shaft was isolated the pressure within it did not vary over the duration of the test. The initial pressure in each level stairwell may have varied due to different ambient conditions.

The maximum calibrated range for the differential pressure transducers in the stairwell on Levels 1, 1M, 2 and 3 are  $\pm 62.5$  Pa,  $\pm 62.5$  Pa,  $\pm 125$  Pa, and  $\pm 62.5$  Pa respectively (Figure FOX-23).

## 8.8 Optical Density

Optical density (dB/m) was measured at six different locations. Due to the sensitivity and calibration of the densitometer the optical density presented in this report is only in the range of 0 dB/m to 25 dB/m (Figure FOx-22). This was done as optical density correlates directly with visibility, and an optical density above 25 dB/m is a visibility of less than 0.5 m and therefore larger values are irrelevant.

## 8.9 External Temperature

Only the temperature at the center plane of the grid shown in Figures 20 and 37 were graphed in this report.

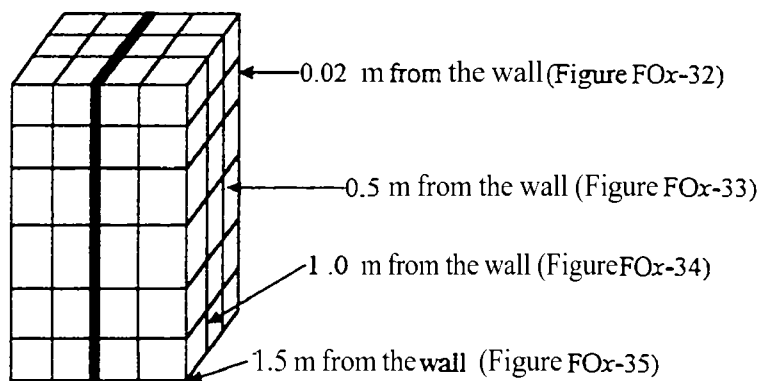

Figure 37: External thermocouple grid

## 9. Flashover Test FO1

**Test Conditions:**     **Burn Room Door Open**  
                               **Level 1 Stairwell Door Closed**

### Observations:

0:00 Ignition  
 2:15 Center cushion well alight  
       Thermal and photo-optical detectors activated  
 3:30 Smoke layer reaching the top of the window (0.4 m from ceiling)  
 4:10 Smoke layer to the top of the couch (1.45 m from ceiling)  
 4:25 Significant bowing of the window  
 4:30 Sprinkler above the small platform activated (detection only)  
 4:40 Initial cracking in the middle pane  
 5:00 Smoke to seat cushion of couch (1.95 m from ceiling)  
 5:20 Smoke layer to floor level  
 5:25 Window lowered-glass *temperature criteria reached*  
 5:42 Sprinkler above large platform activated (detection only)  
 5:54 Sprinkler in Level 1 corridor activated (detection only)  
 6:20 Flames reaching approximately 0.6 m above window opening  
 7:20 Flashover occurs  
 12:00 Flames reaching approximately 1.7 m above the window opening  
 16:10 Left hand panel of Level 1M window dislodged  
 17:30 Bum room door clearly visible through window opening  
 19:30 Very little flaming coming out the bum room window; mainly hot gases  
 28:00 First signs of visible smoke in Level 3 corridor  
 28:50 Smoke layer 0.7 m below the ceiling in Level 3 corridor  
 32:40 Smoke layer to floor level in level 3 corridor

At some stage during the fire the bookcase on the west side of the room partially collapsed onto the small platform; this was the only fire test that this occurred. The carpet just outside the bum room door was burnt on the front edge (closest to the fire), and had a few char marks on it. The P/U in the corridor was unaffected.

**Table 7: Summary of results for Test FO1**

<b>In the Burn Room</b>	
Maximum Heat Release Rate	7.1 Mw
Maximum Peak Temperature	1125 °C
Maximum Average Room Temperature	831 °C
Minimum Oxygen Concentration	0.7 Vol %
Maximum Total Heat Flux	na kW/m <sup>2</sup>
Time untenability reached (1 00°C)	318 s

<b>At the Burn Room Door</b>		
Maximum CO Concentration a		6.7 Vol %
Maximum CO <sub>2</sub> Concentration		10 Vol %
Maximum Temperature		793 °C
Minimum Oxygen Concentration		0.6 Vol %
<b>In Level 1 Corridor</b>		
Maximum Temperature 1.5 m above the floor		409 °C
Maximum Temperature in the center of the Corridor		408 °C
<b>Stairwell</b>		
Maximum Temperature	Level 1	17 °C
	Level 1M	15 °C
	Level 2	15 °C
	Level 3	16 °C
<b>Level 3 Corridor</b>		
Maximum Temperature		15 °C
<b>External</b>		
Maximum External Temperature		630 °C
Maximum Total Heat Flux		28 kW/m <sup>2</sup>

Note: A full list of detector and sprinkler activation times is shown in Tables 15 and 16. Only the time for the first detector activated is listed in the above observations.

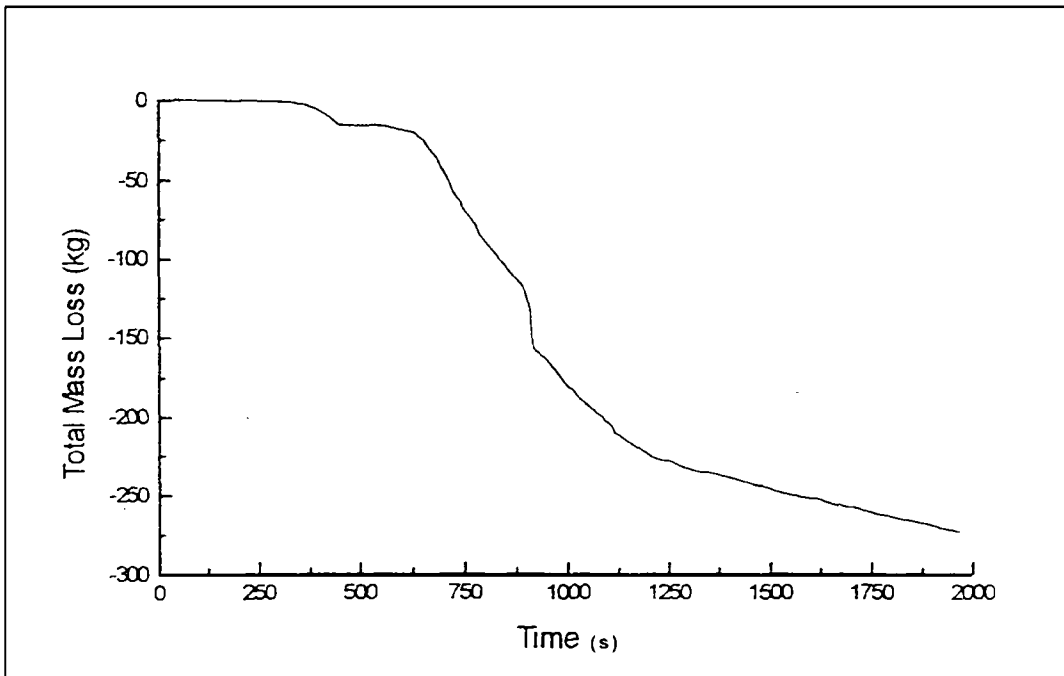

Figure FO 1- 1: Combined mass loss in the bum room

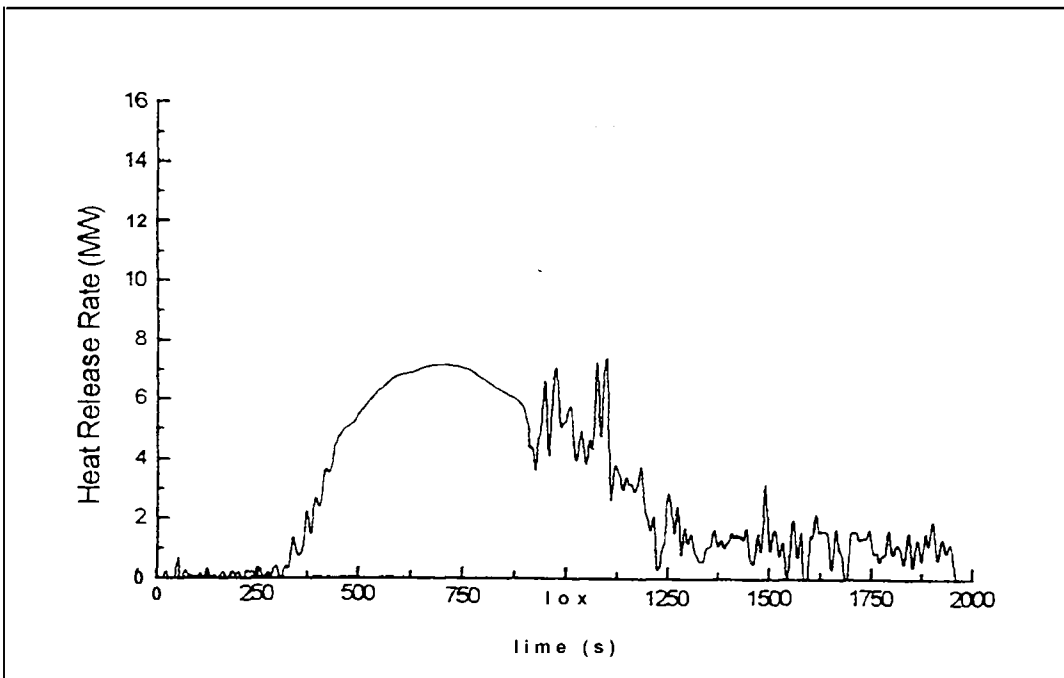

Figure FO 1-2: Total heat release rate in the bum room

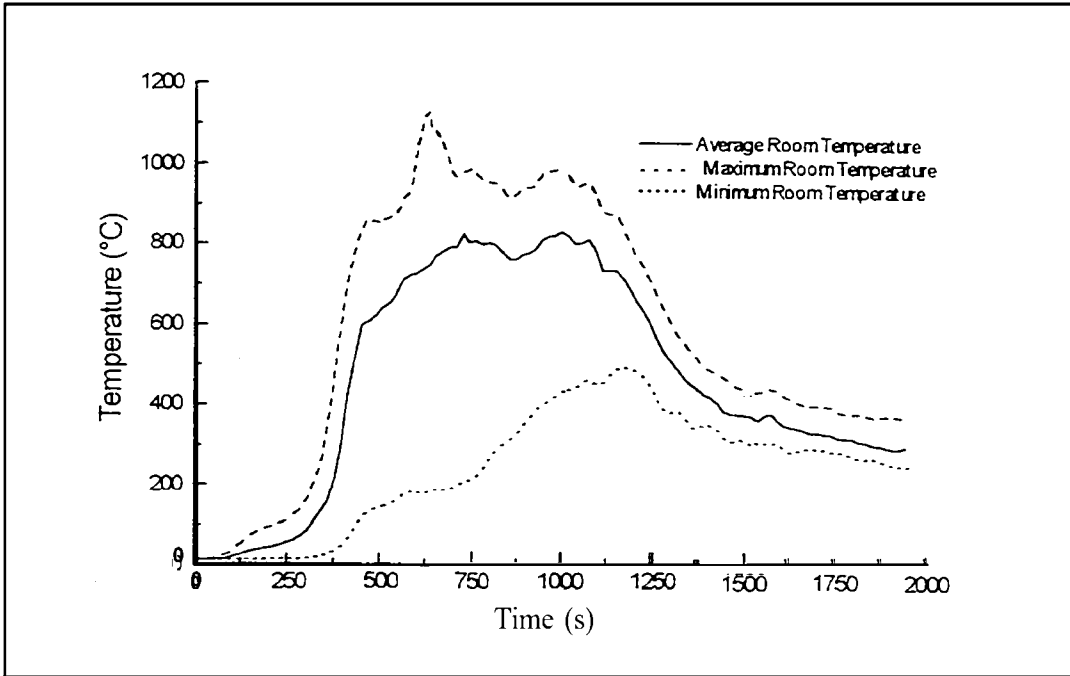

Figure FO1-3 : Average, maximum and minimum temperatures in the bum room

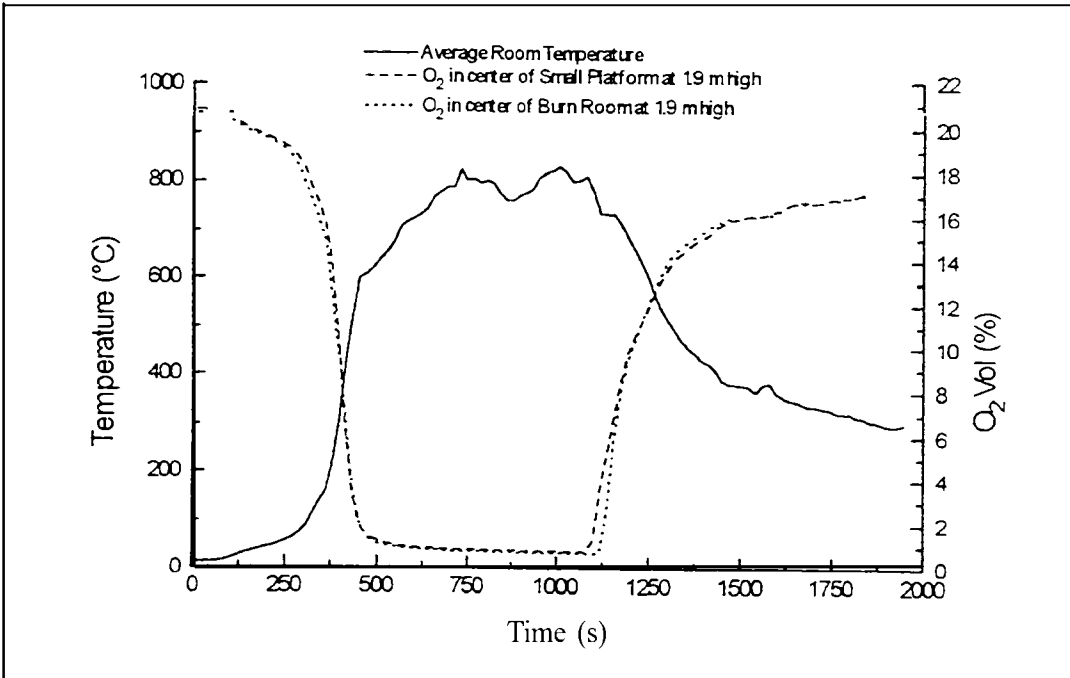

Figure FO 1-4: Oxygen concentration and average temperature in the bum room



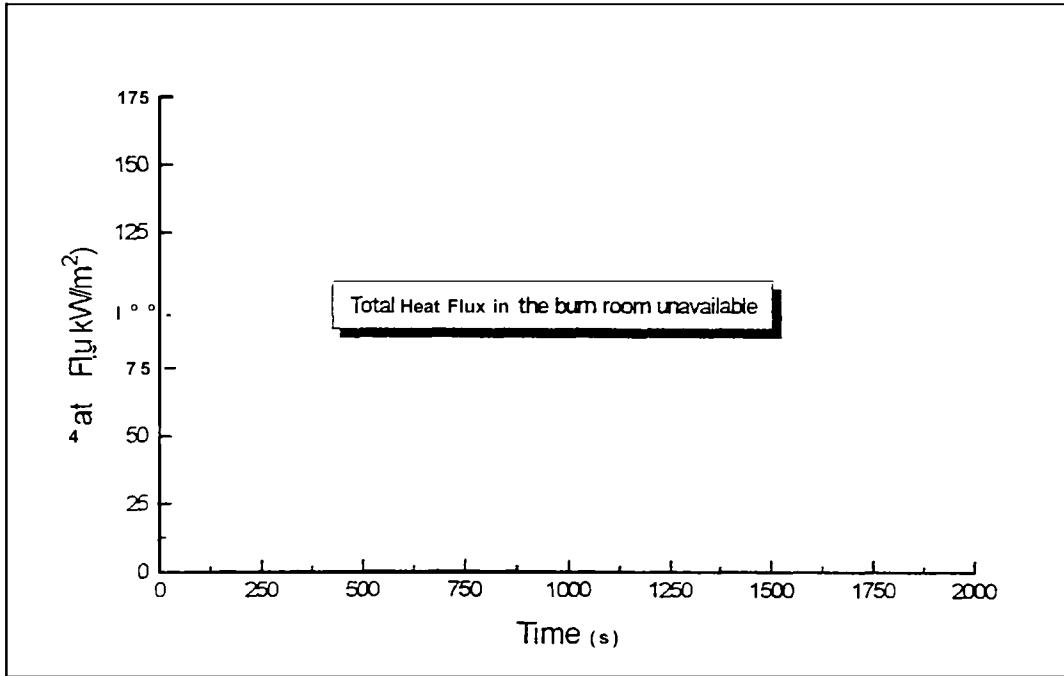

Figure FO 1-5: Total heat flux in the center of the bum room

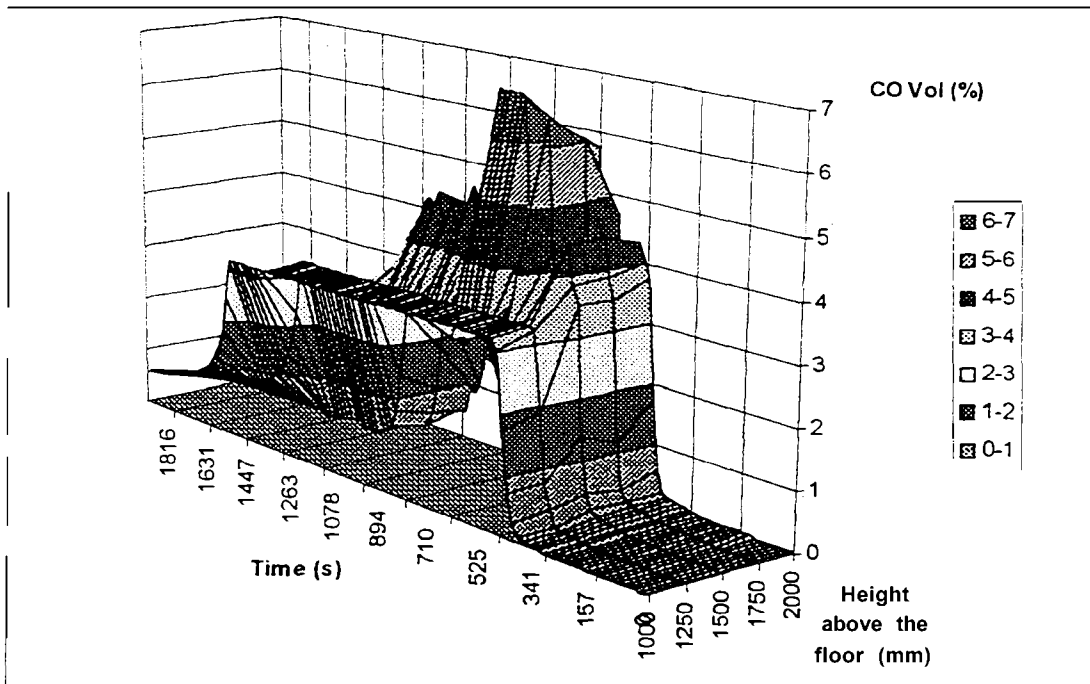

Figure FO1-6: Carbon monoxide concentration along the center line of the bum room door

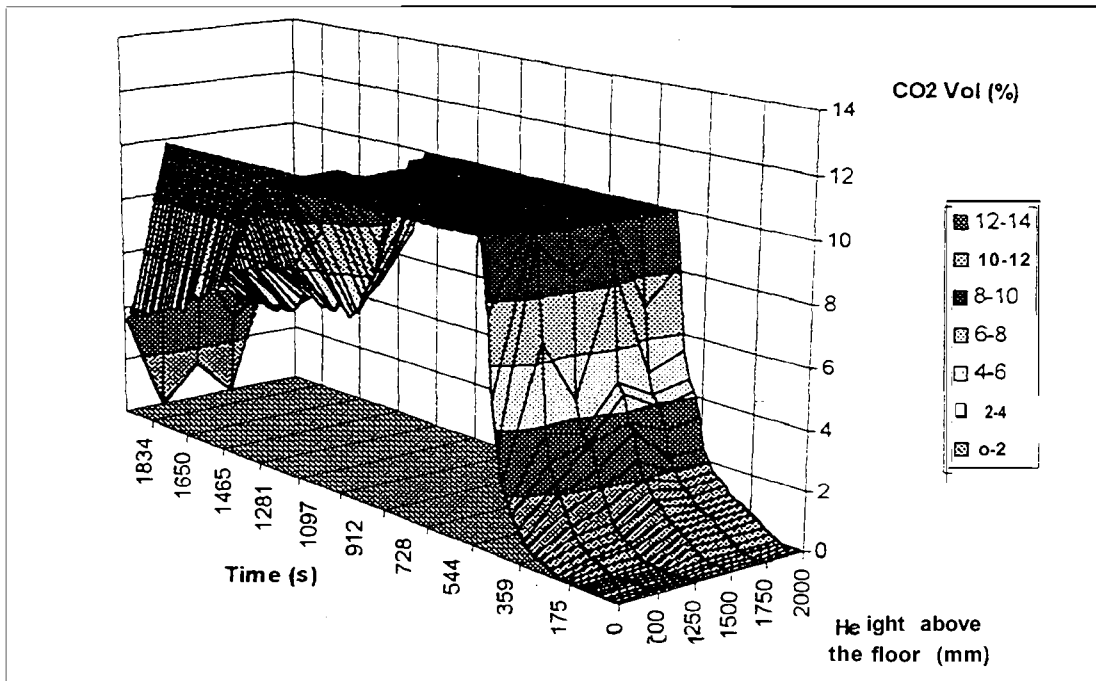

Figure FO1-7: Carbon dioxide concentrations along the center line of the bum room door

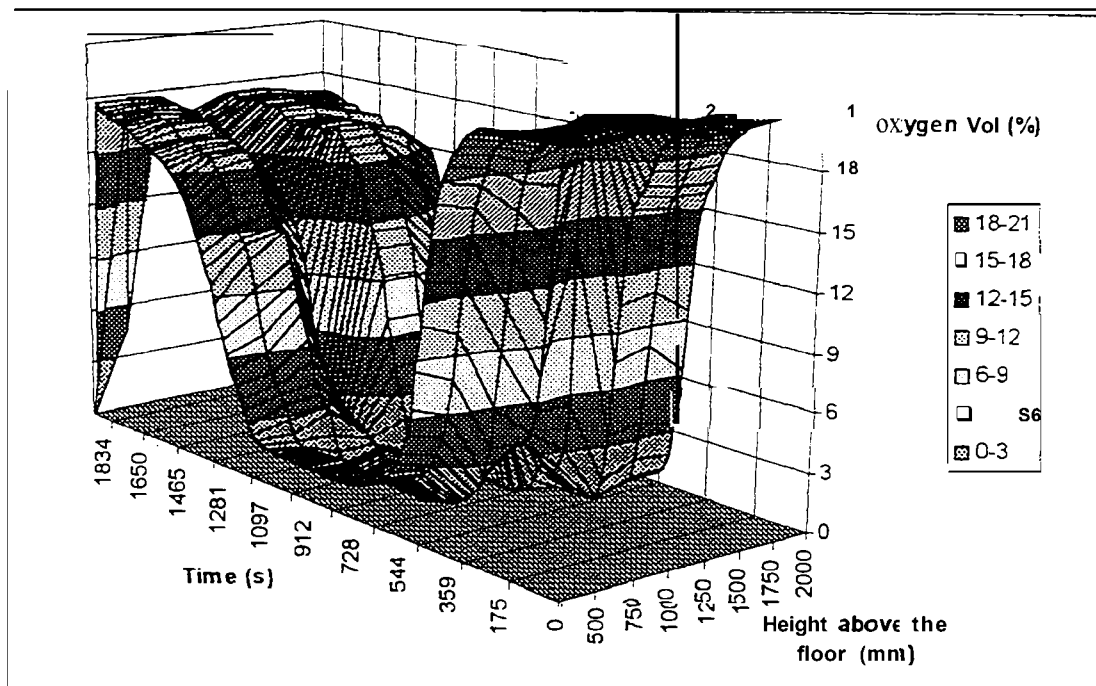

Figure FO1-8: Oxygen concentrations along the center line of the bum room door

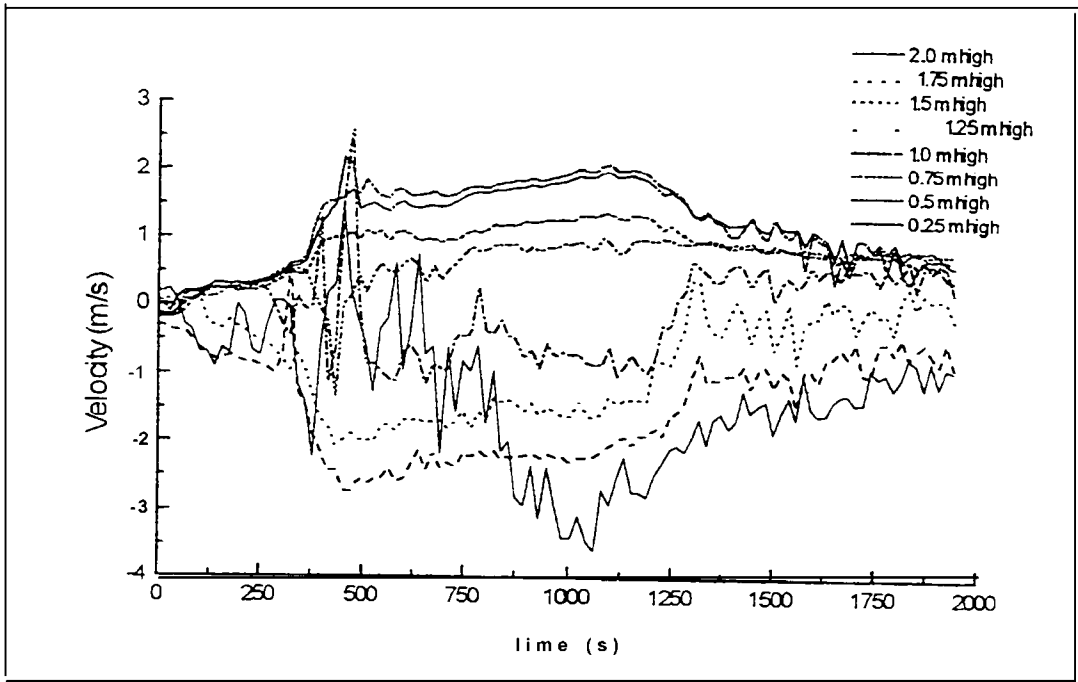

Figure FO I-9: Flow velocity distribution at the center line of the bum room door

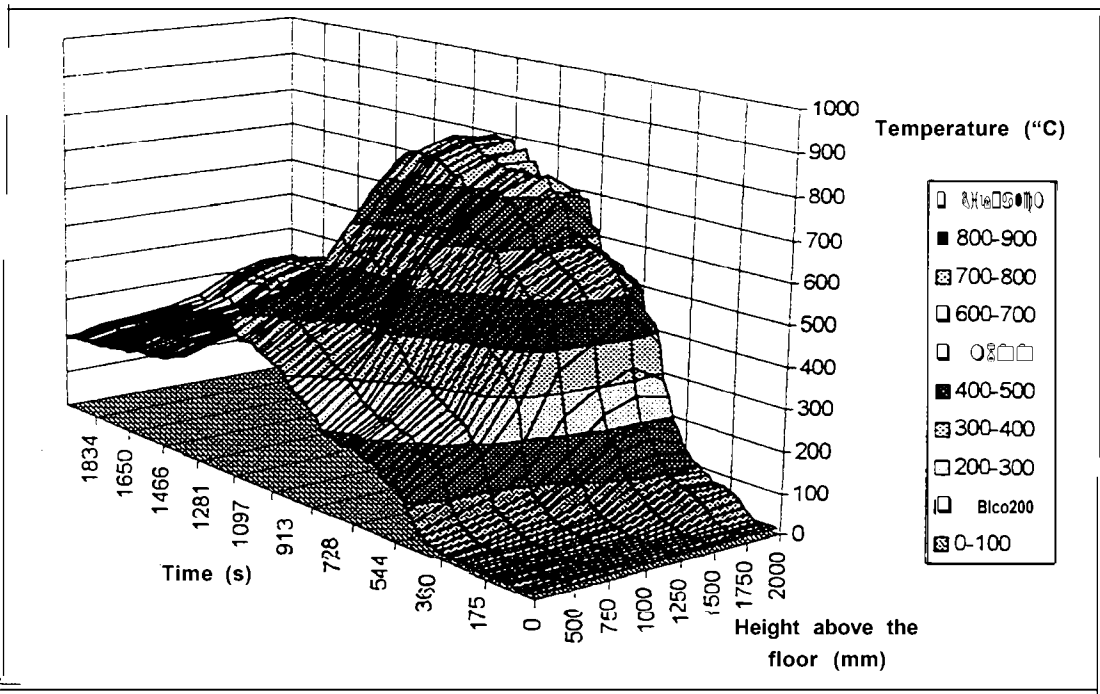

Figure FO I-10: Temperature distribution along the center line of the bum room door

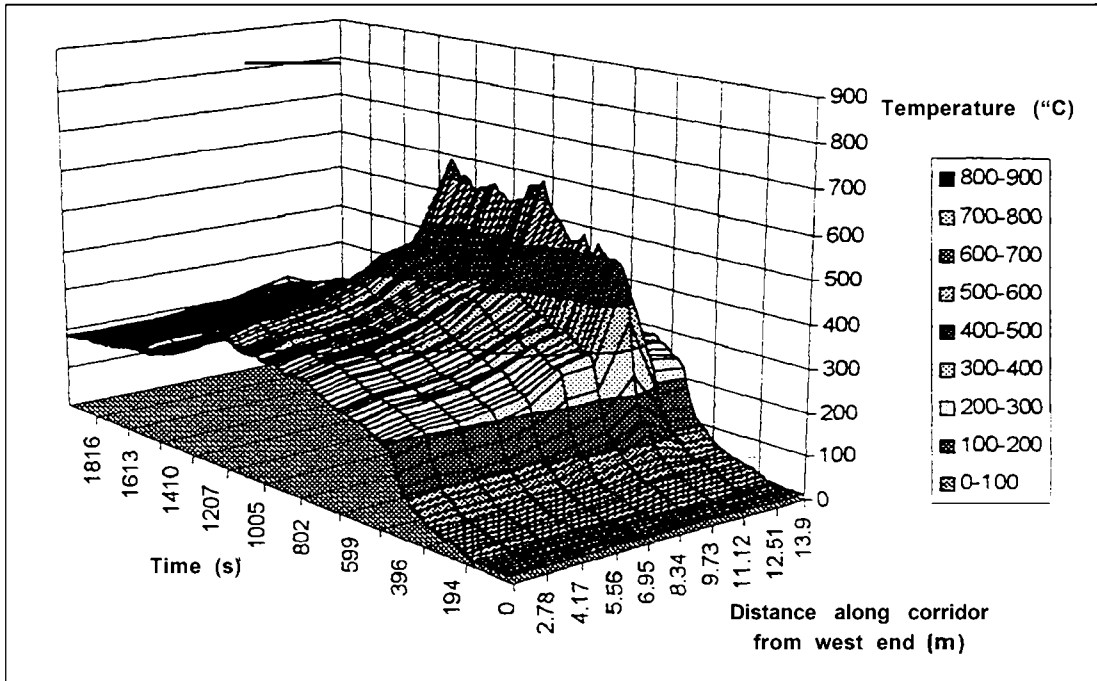

Figure FO1-11: Temperature along Level 1 corridor (2.0 m above the floor)

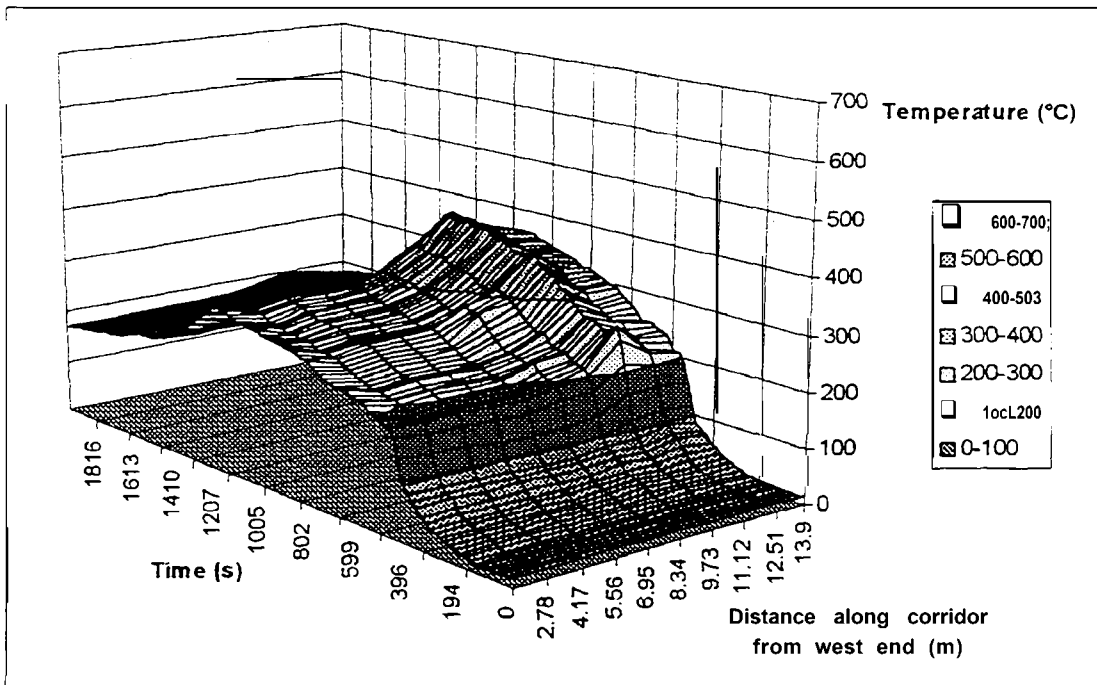

Figure FO1-12: Temperature along Level 1 corridor (1.5 m above the floor)

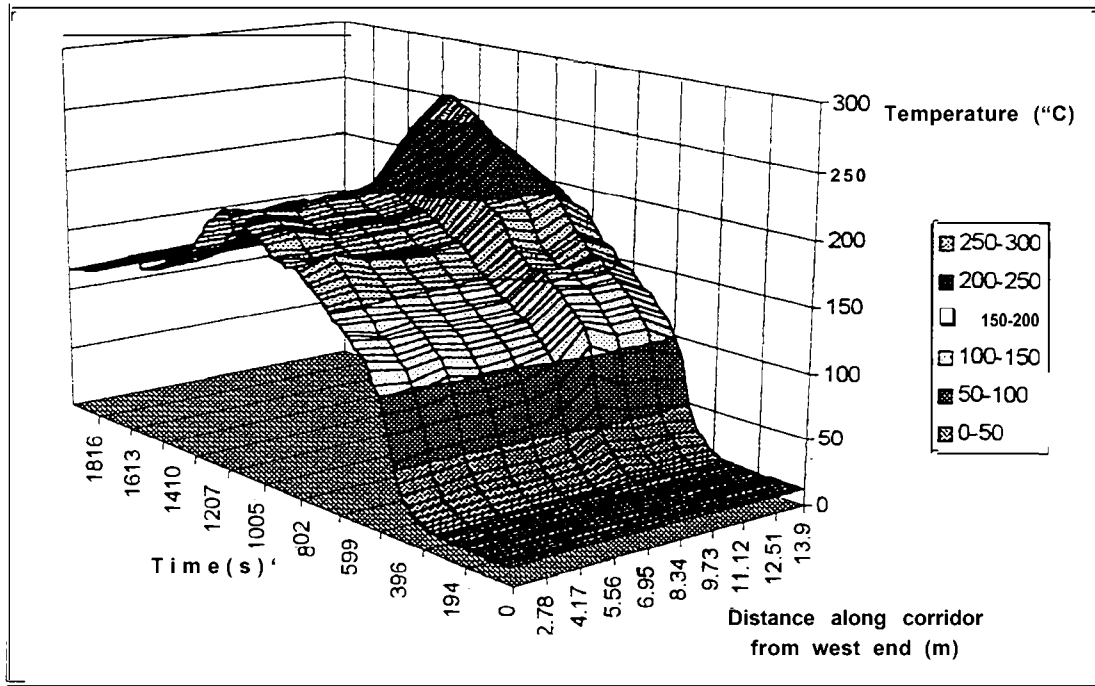

Figure FO 1- 13 : Temperature along Level 1 corridor (0.5 m above the floor)

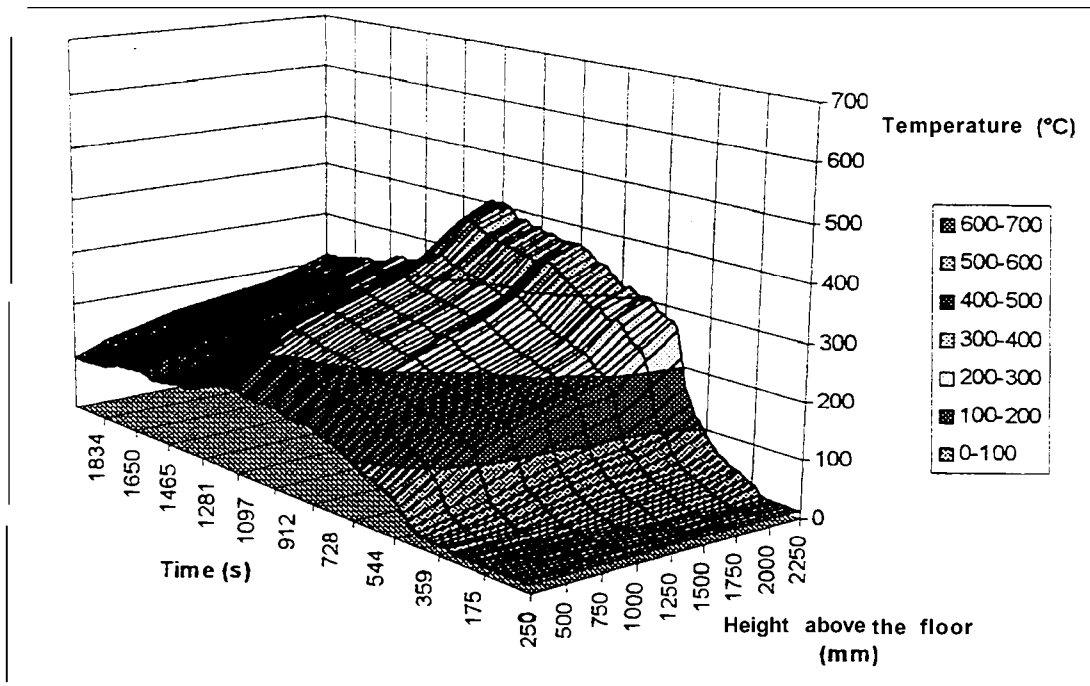

Figure FO1-14: Vertical temperature distribution in the center of Level 1 corridor

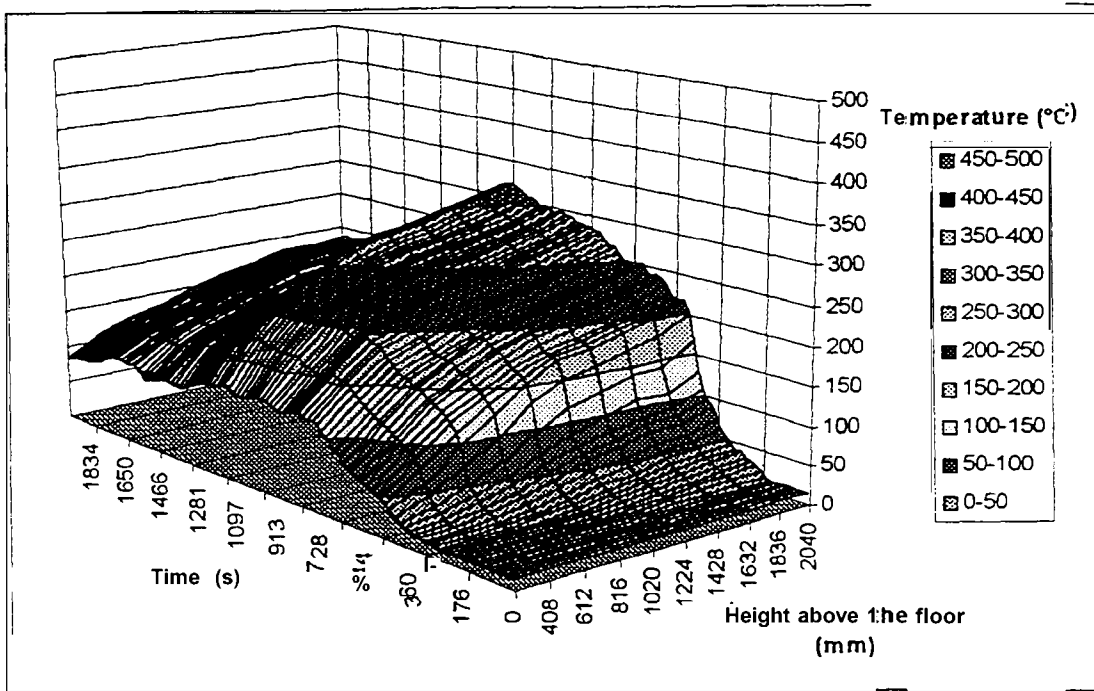

Figure FO1-15: Temperature distribution along the center line of Level 1 stairwell door

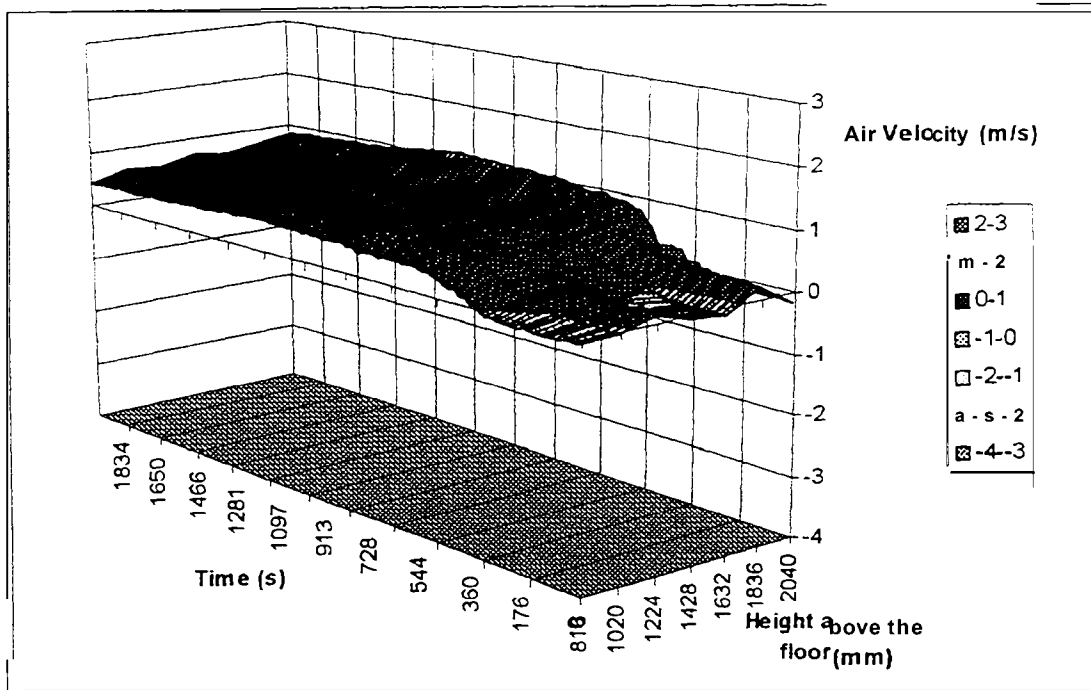

Figure FO1-16: Flow velocity distribution at the center line of Level 1 stairwell door

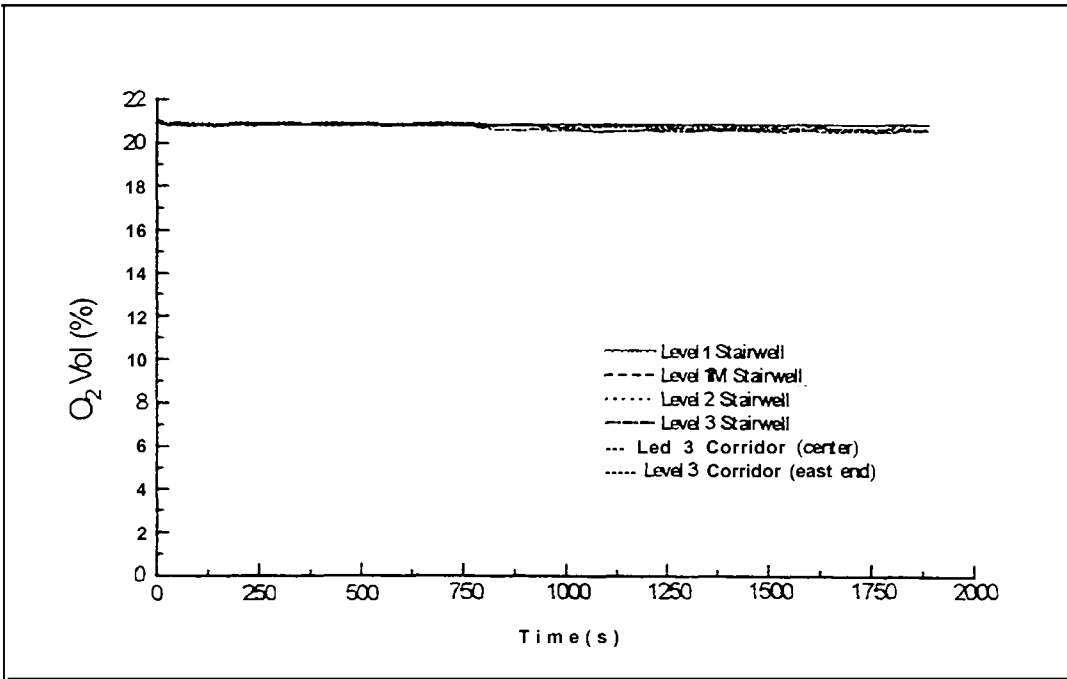

Figure FO 1- 17: Oxygen concentration at the stairwell doors (1.7 m above the floor)

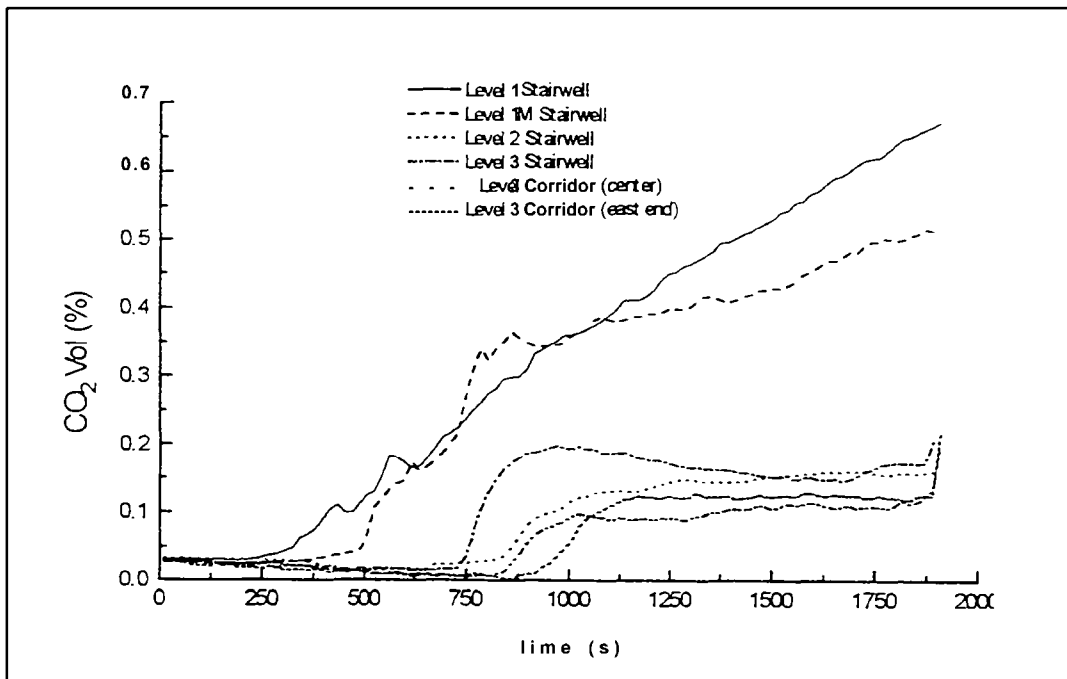

Figure FO 1- 18: Carbon dioxide concentration at the stairwell doors (1.7 m above the floor)

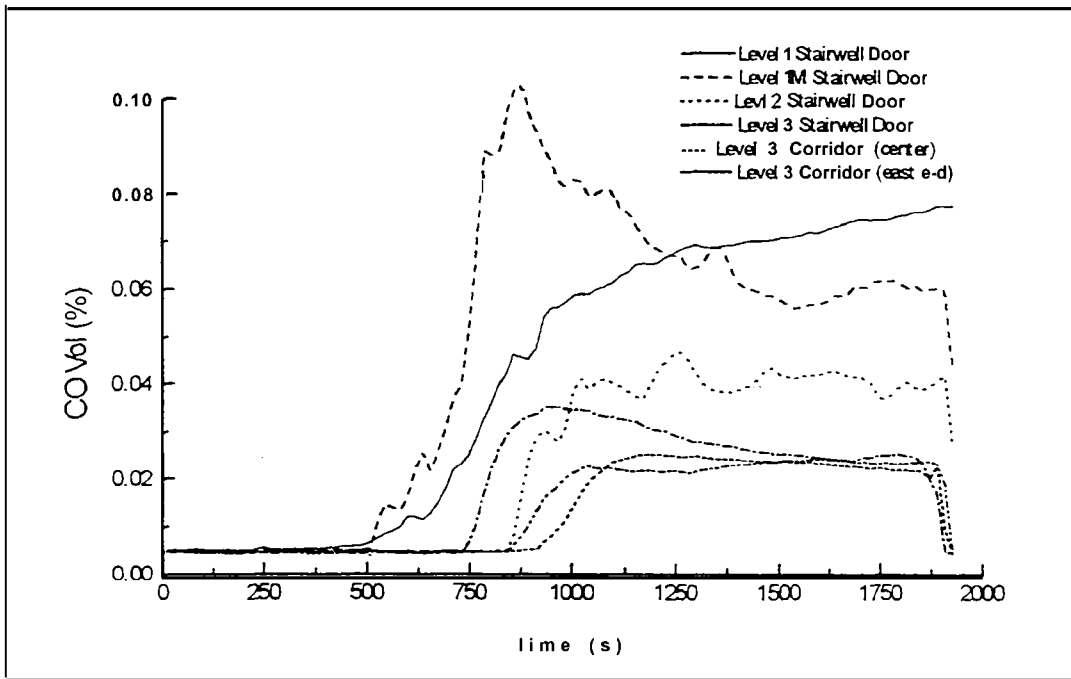

Figure FO1-19: Carbon monoxide concentration at the stairwell doors (1.7 m above the floor)

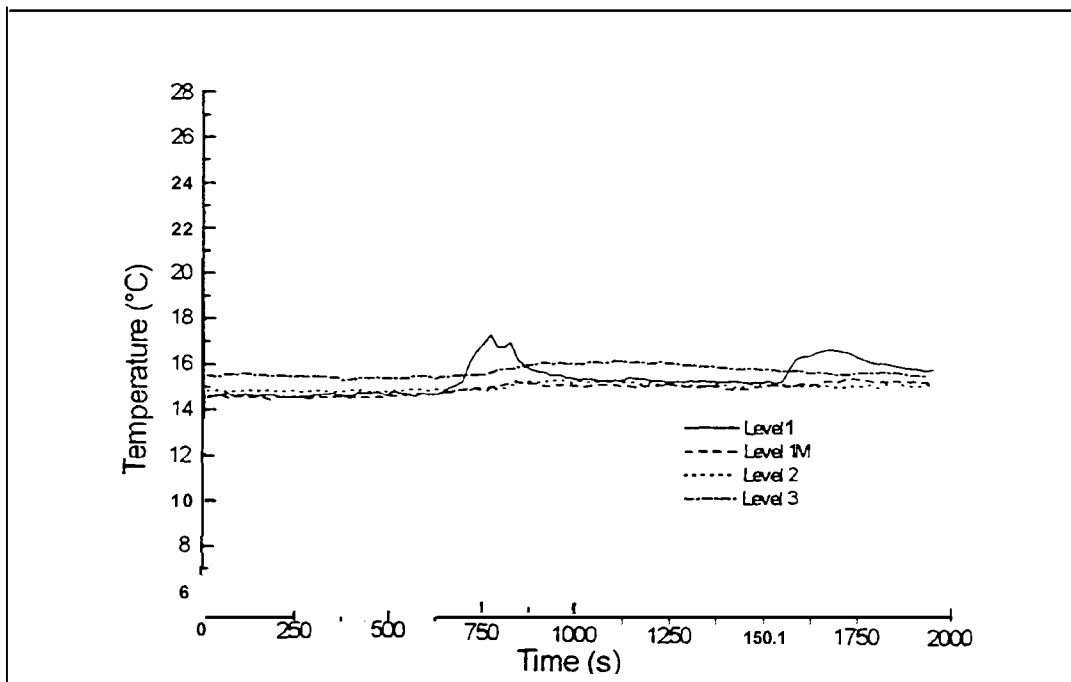

Figure FO 1-20: Temperature in the stairwell at each level -North side (1.7 m above the floor)



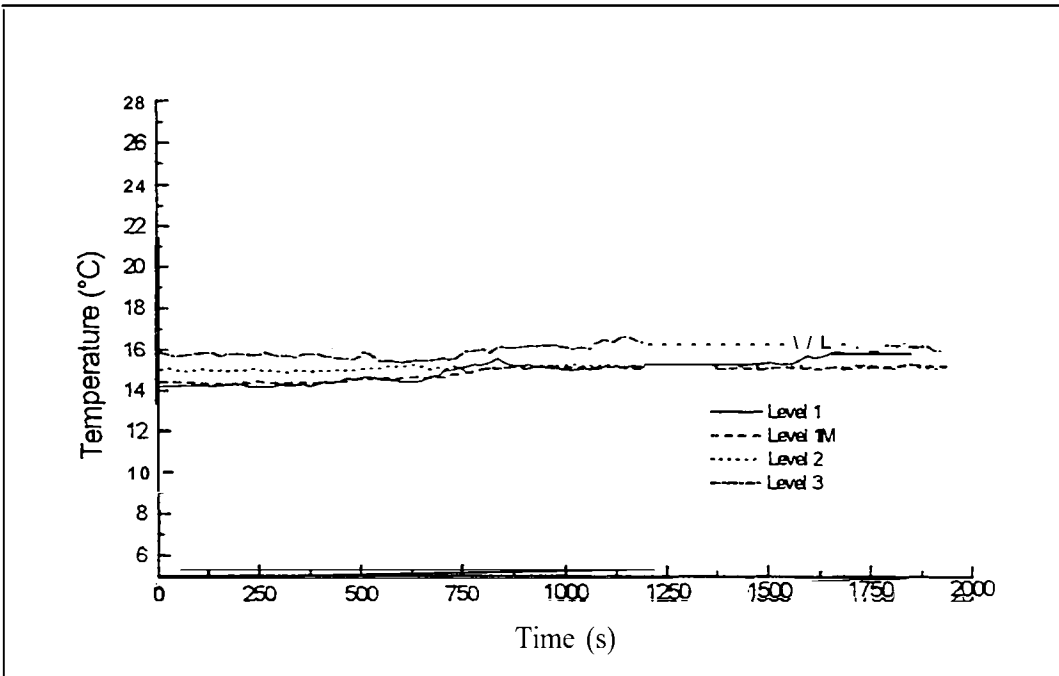

Figure FO1-21: Temperature in the stairwell at each level-South side( 1.7 m above the floor)

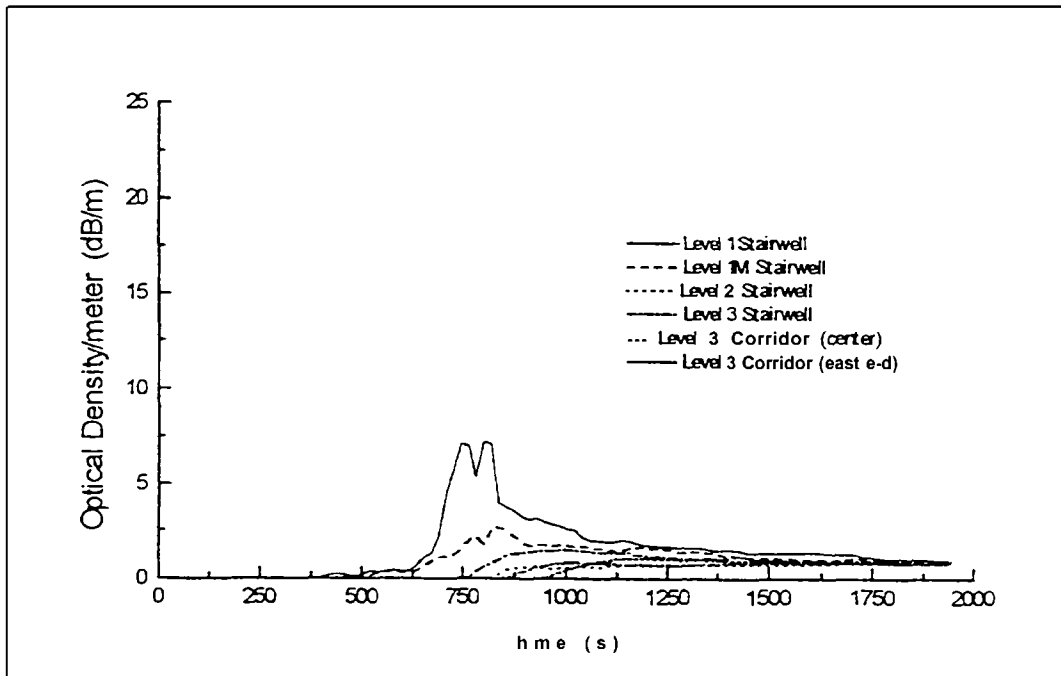

Figure FO1-22: Optical density/m at six locations (1.7 m above the floor)

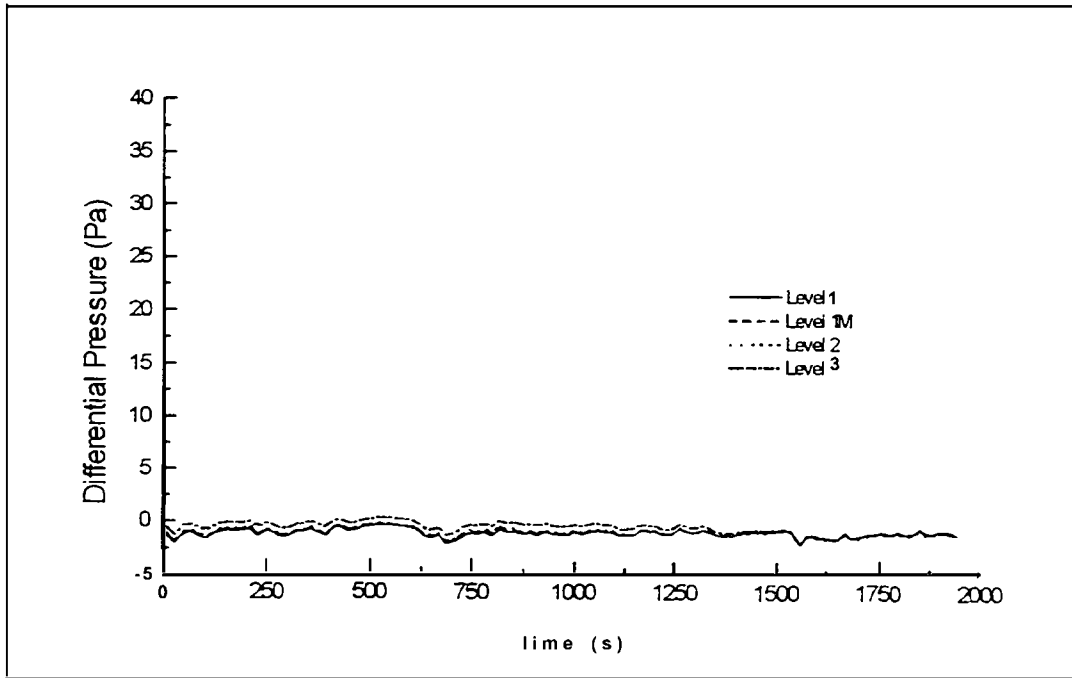

Figure FO I-23 : Pressure differences between outside and the stairwell at each level (1.7 m above the floor)

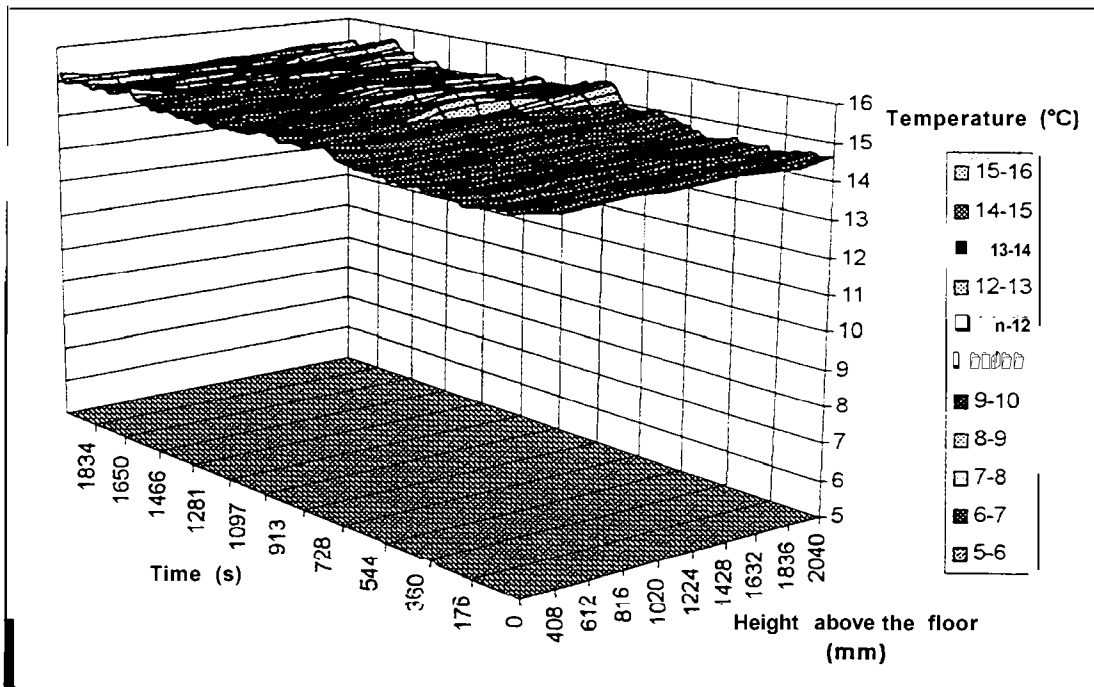

Figure FO1-24: Temperature distribution along the center line of Level 1M stairwell door

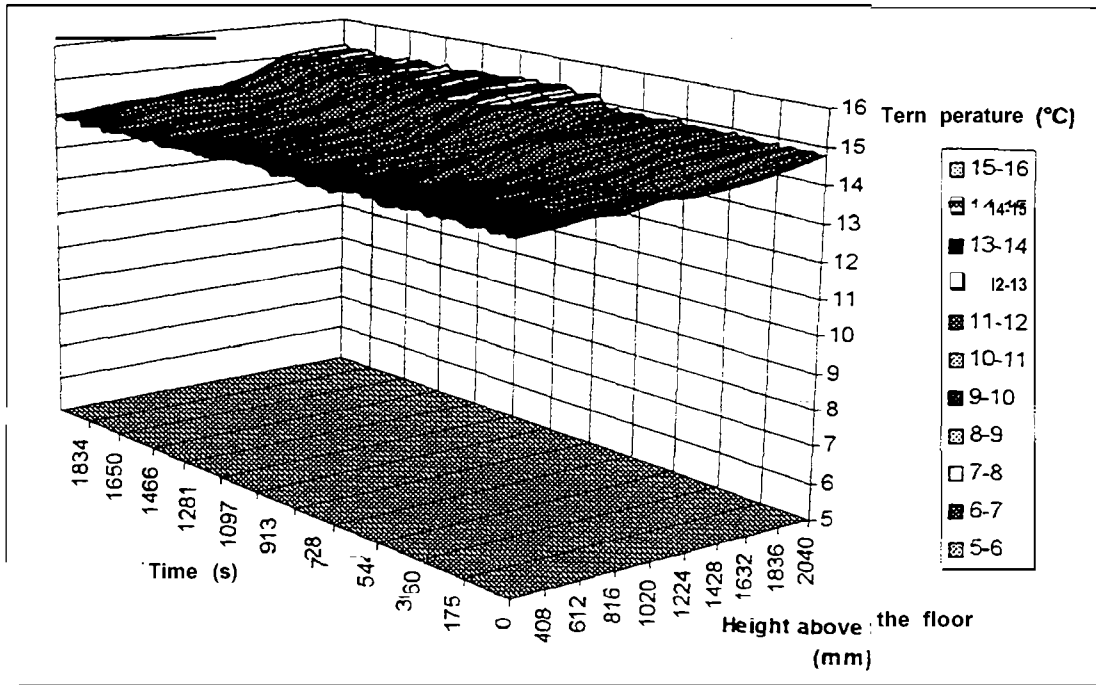

Figure FO1-25: Temperature distribution along the center line of Level 2 stairwell door

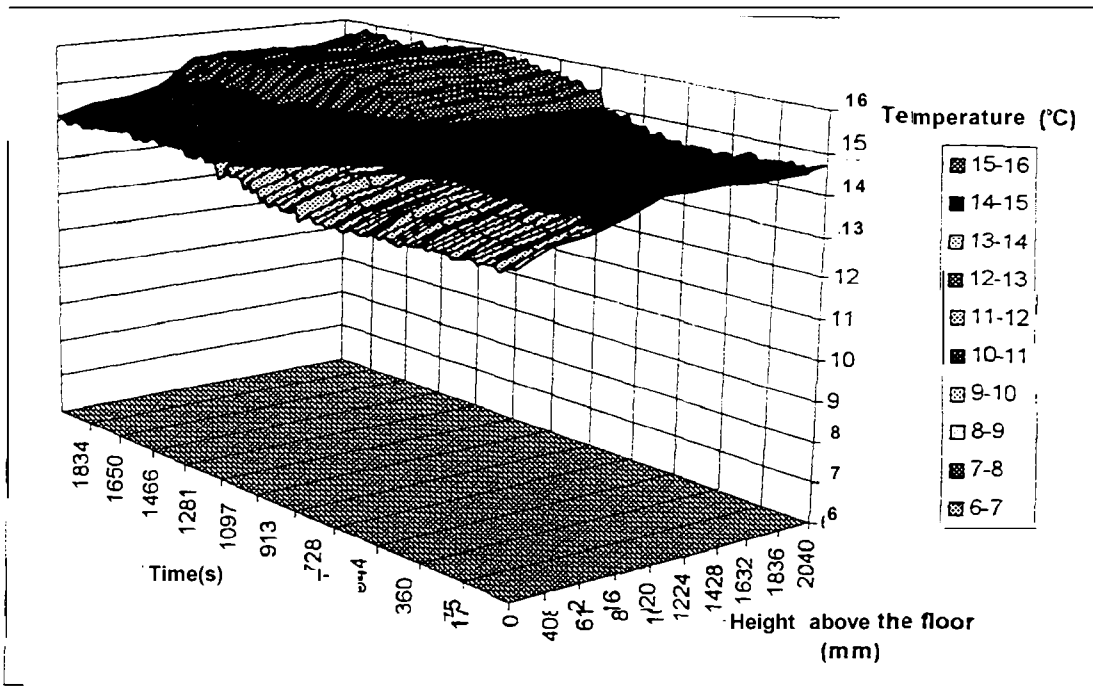

Figure FO1-26: Temperature distribution along the center line of Level 3 stairwell door

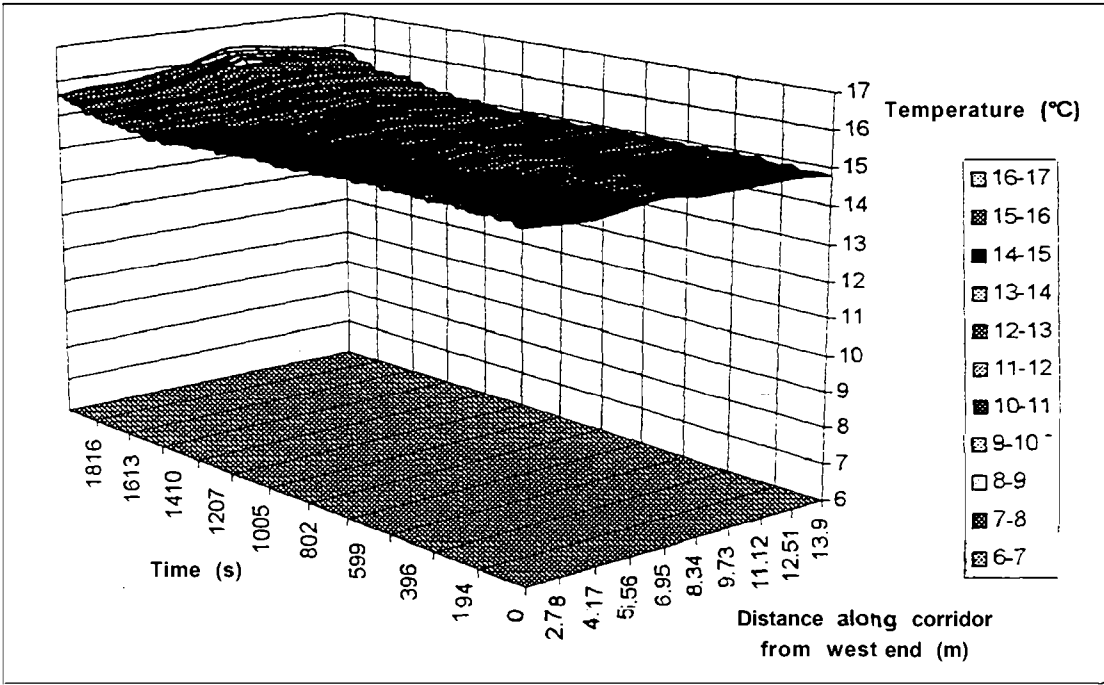

Figure FOI-27: Temperature distribution along Level IM corridor (1.7 m above the floor)

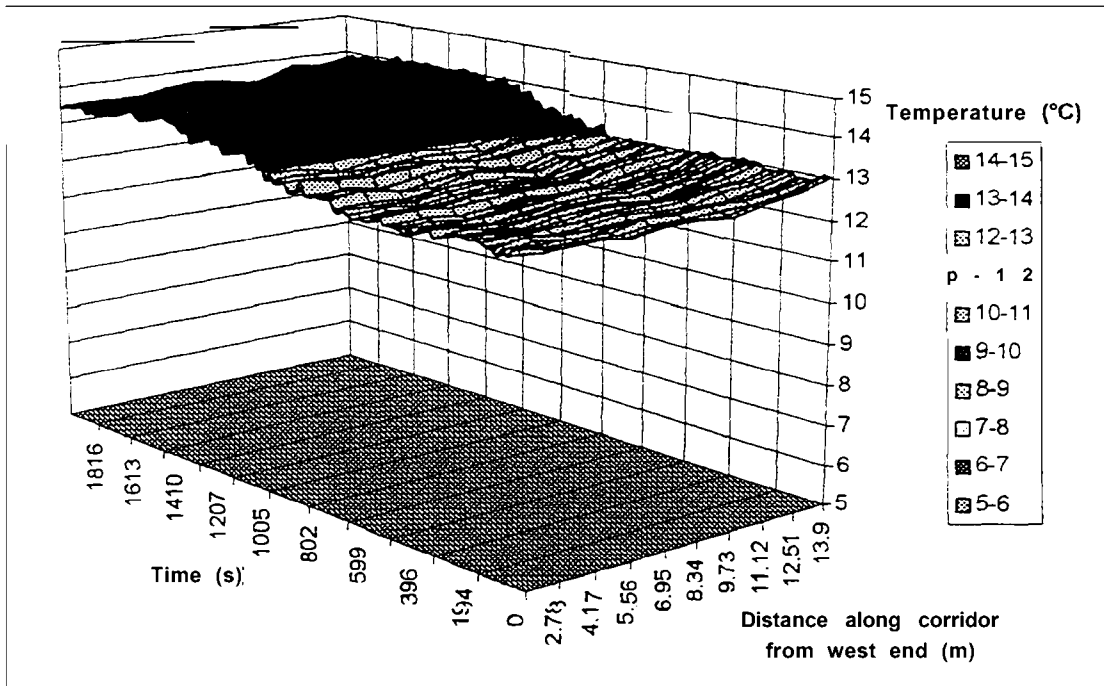

Figure FO I-28: Temperature distribution along Level 2 corridor (1.7 m above the floor)

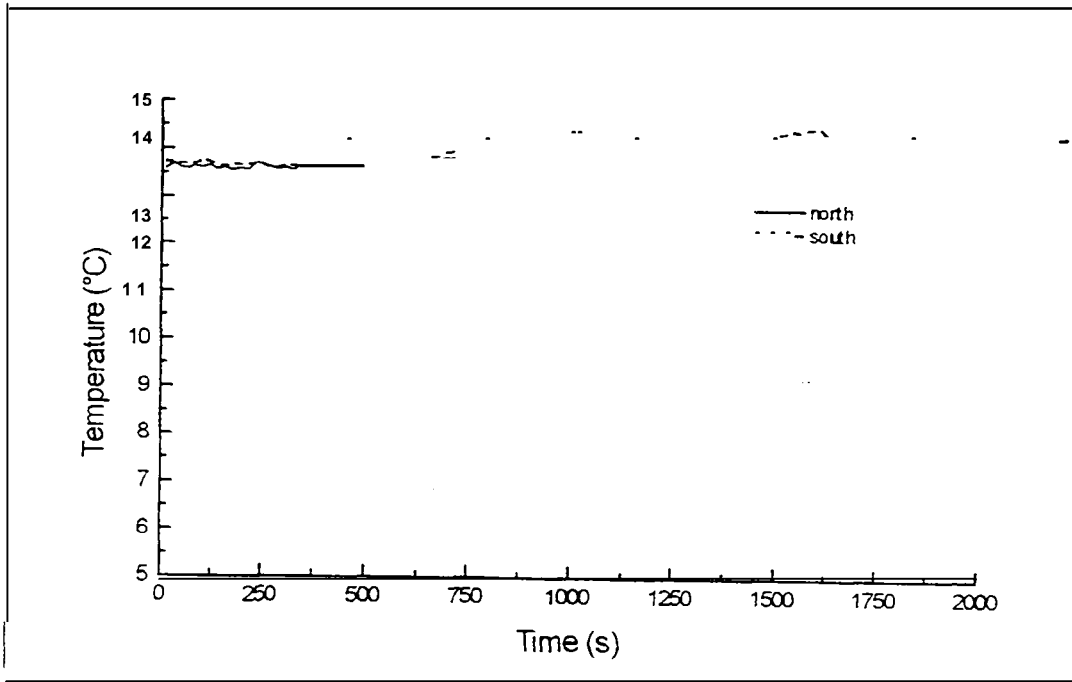

Figure FO I-29: Temperatures in Room 20 1 (1.7 m high)

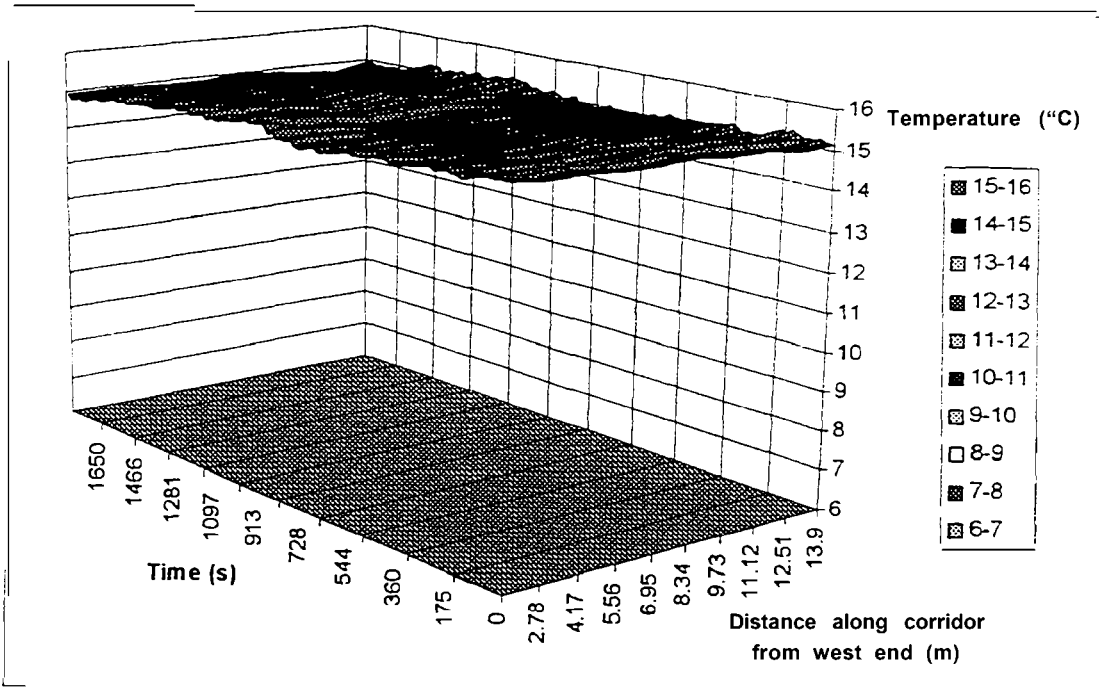

Figure FO1-30: Temperature distribution along Level 3 corridor (1.7 m above the floor)

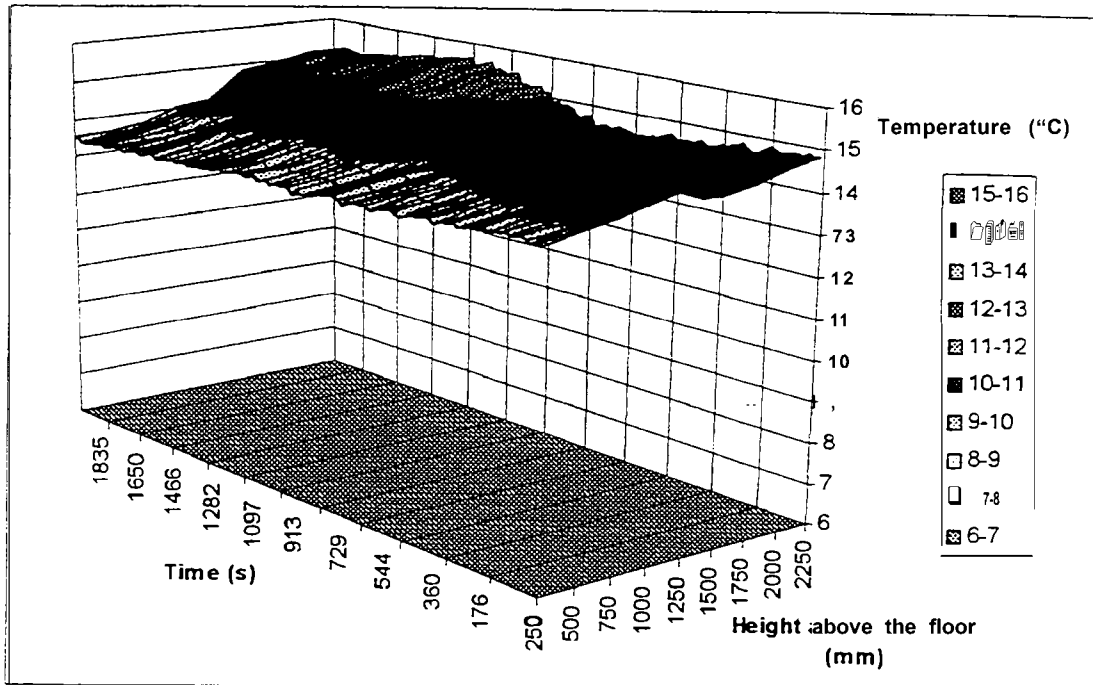

Figure FO 1-3 1: Vertical temperature distribution in the center of Level 3 corridor

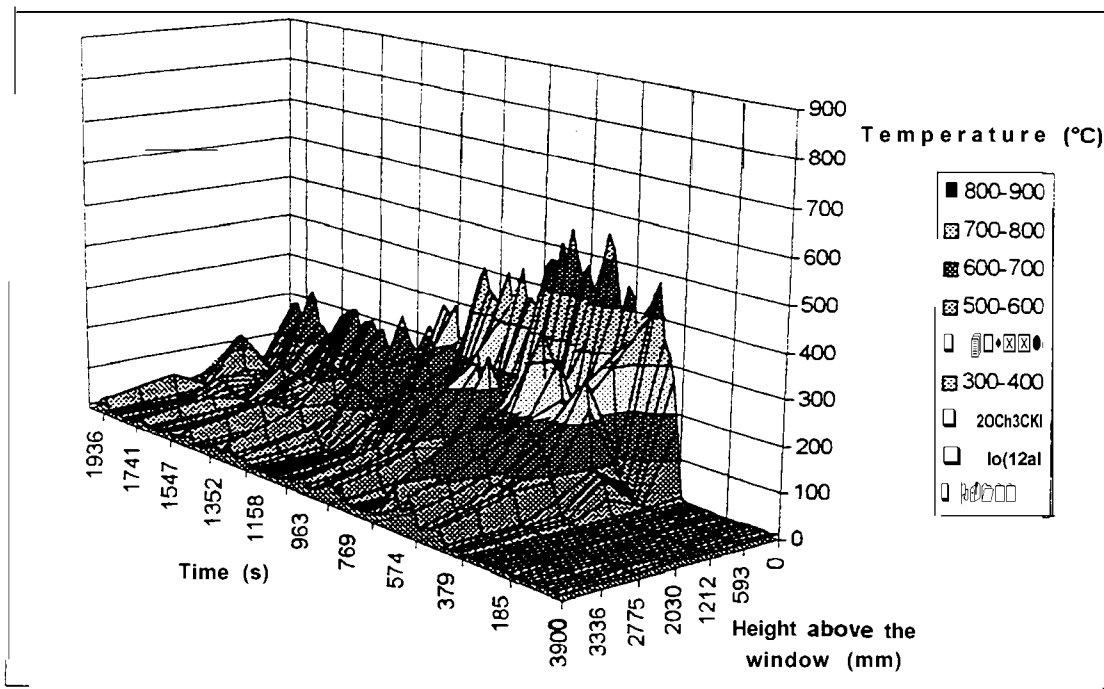

Figure FO1-32: External temperature along the center line of the bum room window (0.02 m from the wall)

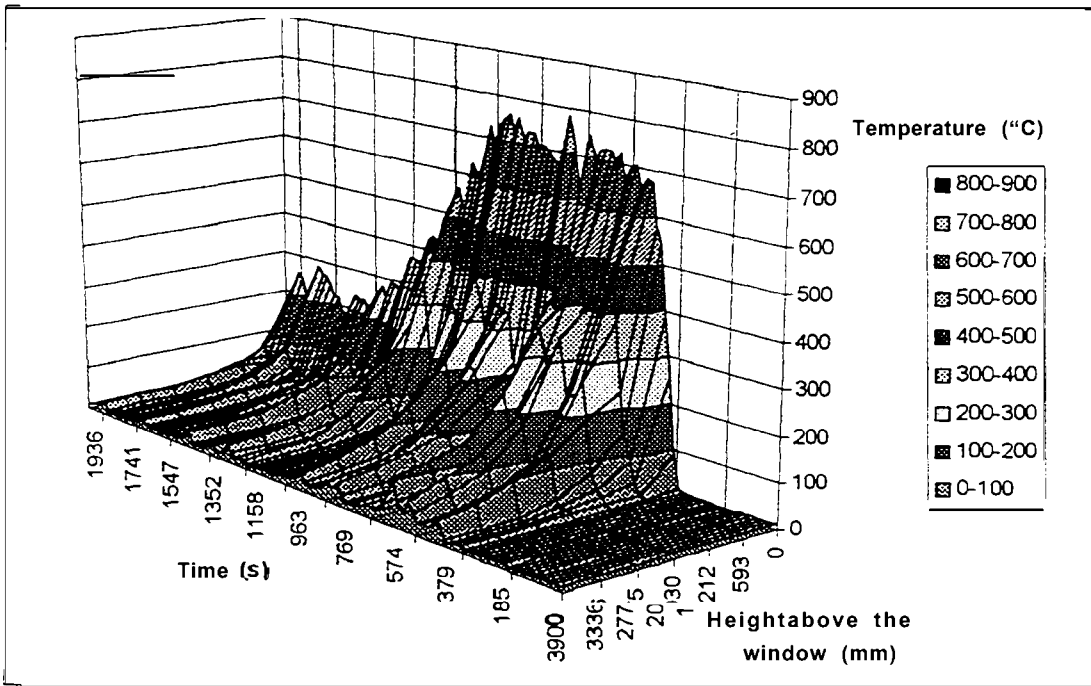

Figure FOI-33 : External temperature along the center line of the bum room window (0.5 m from the wall)

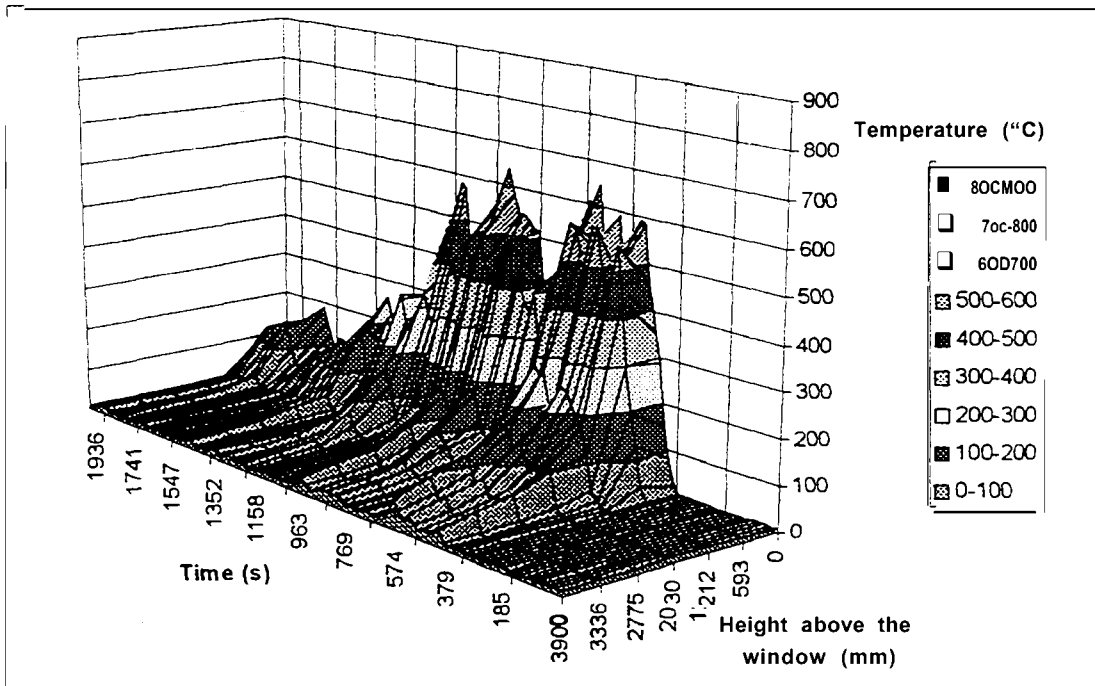

Figure FOI-34: External temperature along the center line of the bum room window (1.0 m from the wall)

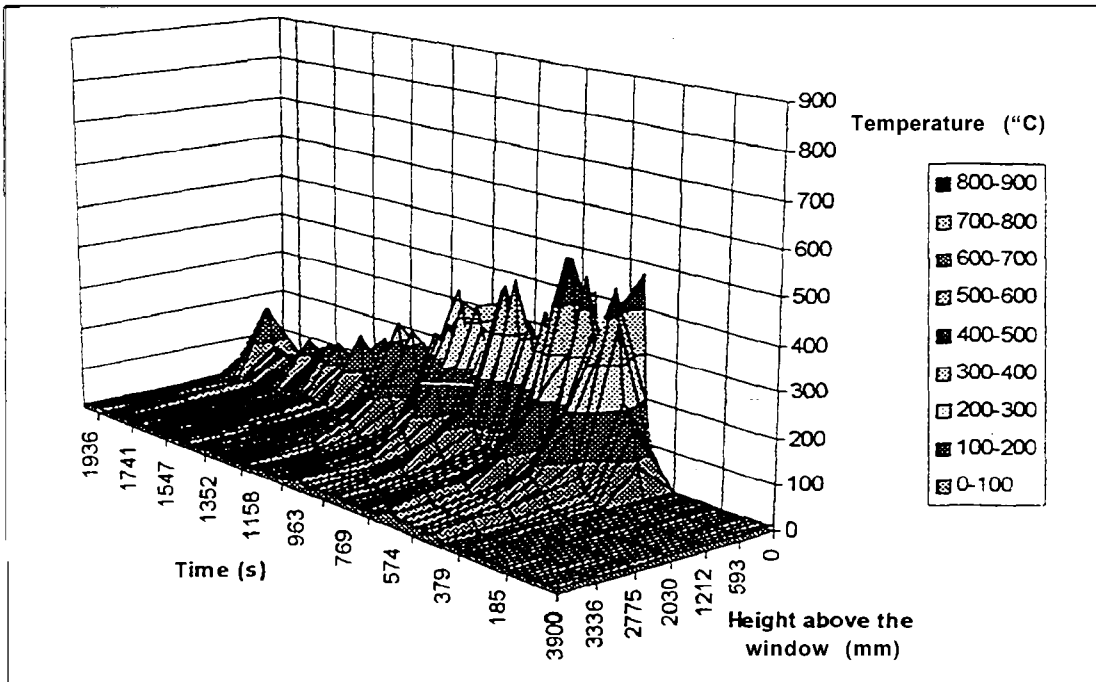

Figure FO 1-35: External temperature along the center line of the bum room window (1.5 m from the wall)

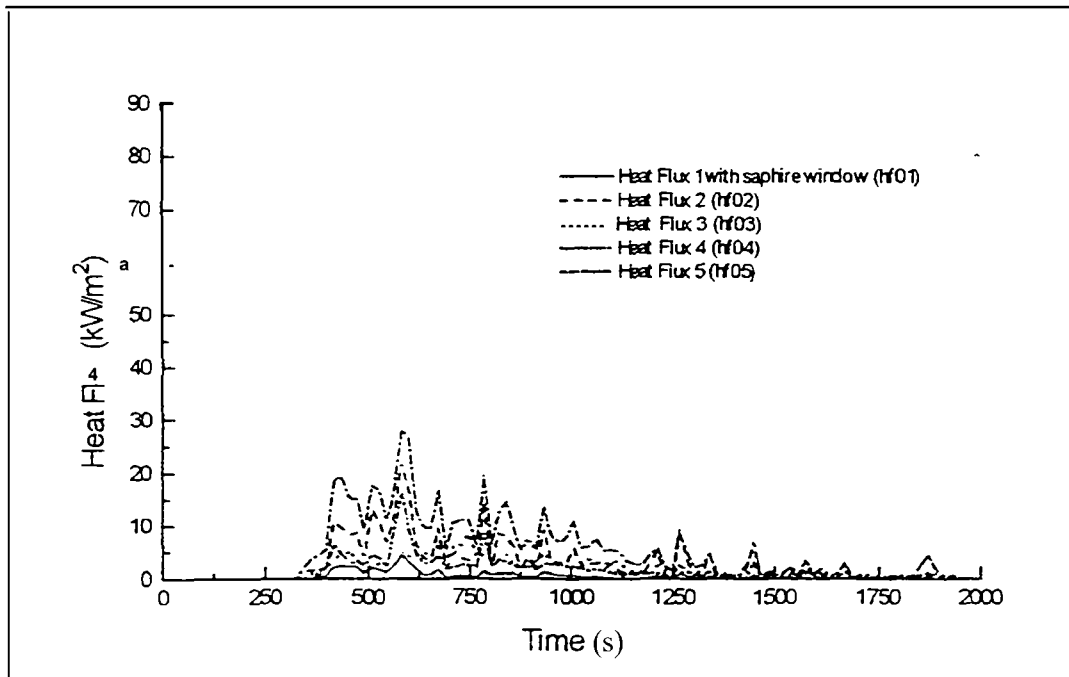

Figure FO1-36: External heat flux measurements (Refer to Figure 25 for locations)



## 10. Flashover Test FO2

**Test Conditions:**     **Bum Room Door Closed**  
                               **Level 1 Stairwell Door Closed**

### Observations:

0:00 Ignition  
 0:50 Ionisation detector activated  
 3:20 Smoke layer to floor level  
       Sprinkler above the small platform activated (detection only)  
 3:50 Significant bowing of the window  
 4:40 Initial crack in the middle pane  
       Sprinkler above the large platform activates (detection only)  
 6:30 Flaming no longer visible through the window-(fire dying out)  
 7:20 More cracking down center of middle pane  
 9:50 ***Initial part of test declared finished***  
       Window lowered  
 10:50 No flames coming out the window  
 13:50 Flames 0.5 m high above the window opening  
 14:20 Flashover occurs  
 18:05 Initial dislodgment of Level 1M window  
       Flames 2.0 m above bum room window opening  
 18:25 More dislodgment of left and middle pane (1M window)  
 18:55 Remaining glass in left pane dislodged (1M window)  
 20:50 Remaining glass in center pane dislodged (1M window)  
 25:30 Bum room door clearly visible through window opening

Although the first half of this fire test died out as it was ventilation limited the second half was quite severe due to the initial build up of hot gases and the pre heat of the fuel load. Despite this, the sprinkler in Level 1 corridor did not activate and the P/U and the carpet in Level 1 corridor were unaffected by fire.

**Table 8: Summary of results for Test F02**

<b>In the Burn Room</b>	
Maximum Heat Release Rate	10.8 MW
Maximum Peak Temperature	1066 °C
Maximum Average Room Temperature	984 °C
Minimum Oxygen Concentration	na Vol %
Maximum Total Heat Flux	146 kW/m <sup>2</sup>
Time untenability reached (100°C)	249 s

<b>At the Burn Room Door</b>		
Maximum CO Concentration a		na Vol %
Maximum CO <sub>2</sub> Concentration		na Vol %
Maximum Temperature		850 °C
Minimum Oxygen Concentration		na Vol %
<b>In Level 1 Corridor</b>		
Maximum Temperature 1.5 m above the floor		32 °C
Maximum Temperature in the <b>center</b> of the Corridor		42 °C
<b>Stairwell</b>		
Maximum Temperature	Level 1	12 °C
	Level 1M	12 °C
	Level 2	13 °C
	Level 3	15 °C
<b>Level 3 Corridor</b>		
Maximum Temperature		15 °C
<b>External</b>		
Maximum External Temperature		890 °C
Maximum Total Heat Flux		60 kW/m <sup>2</sup>

Note: A full list of detector and sprinkler activation times is shown in Table 15 & 16. Only the time for the first detector activated is listed in the above observations.

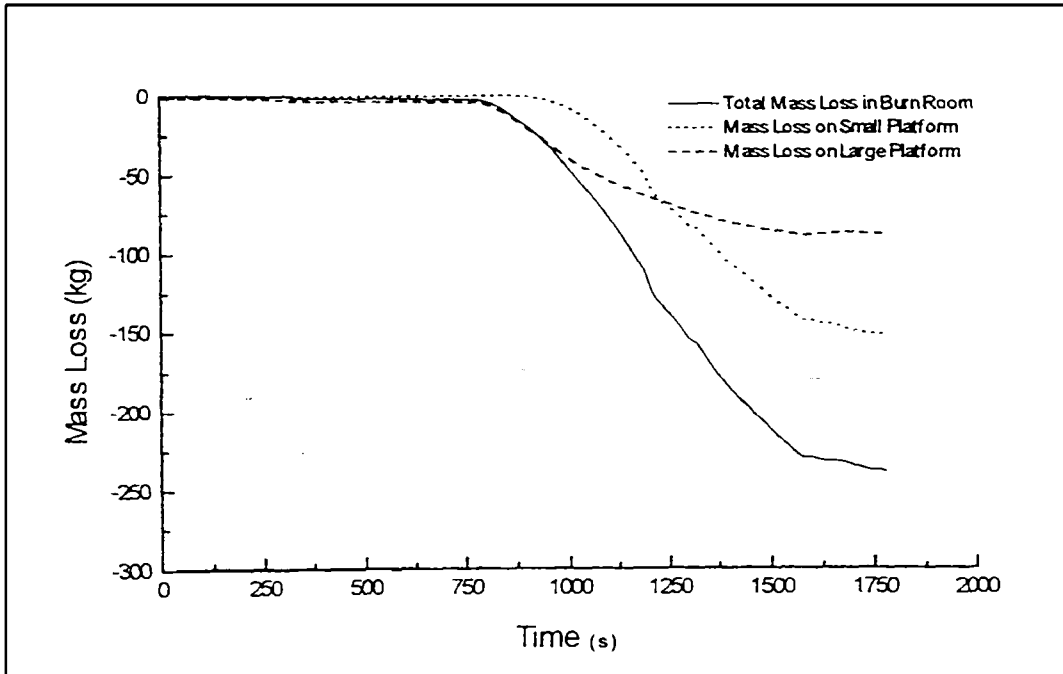

Figure FO2-1: Combined mass loss in the bum room

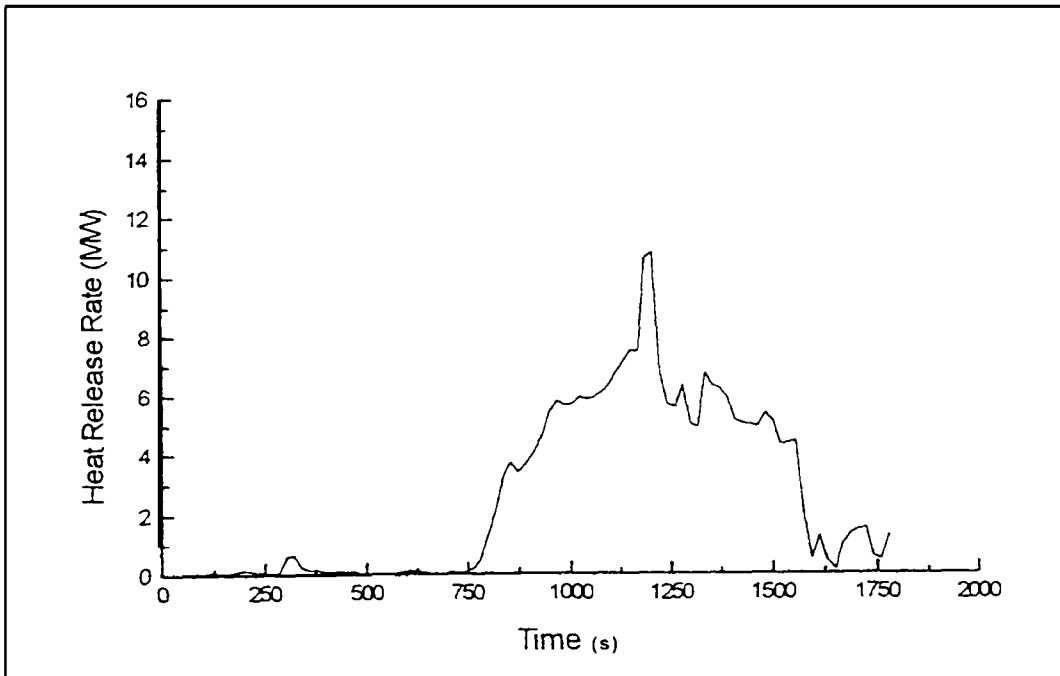

Figure FO2-2: Total heat release rate in the bum room

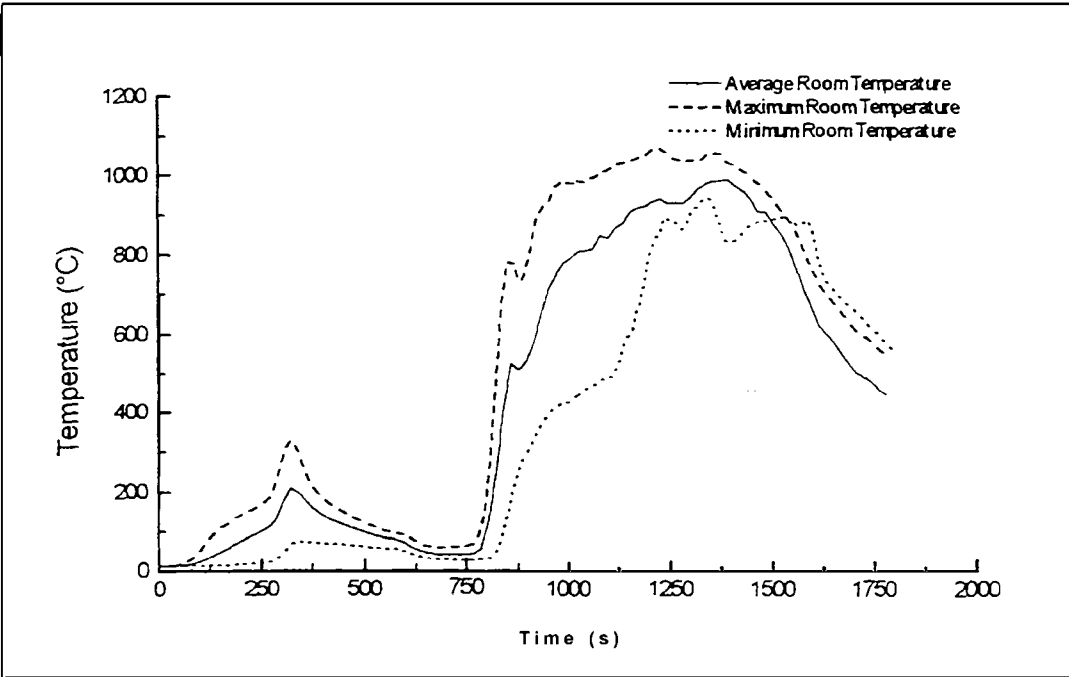

Figure FO2-3 : Average, maximum and minimum temperatures in the bum room

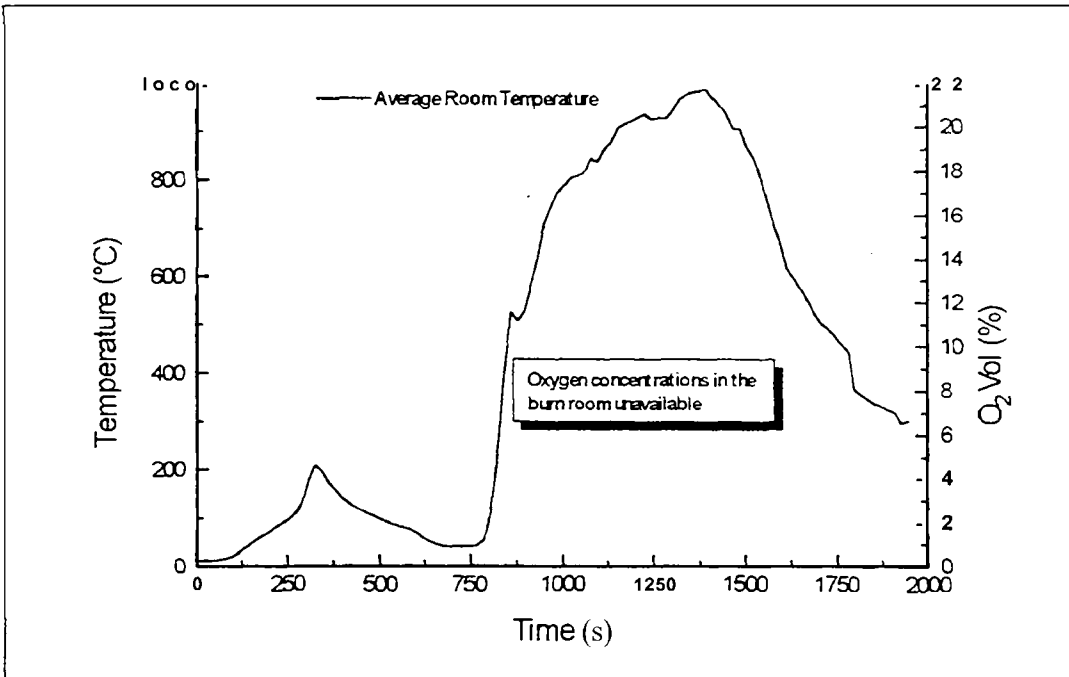

Figure F02-4: Oxygen concentration and average temperature in the bum room

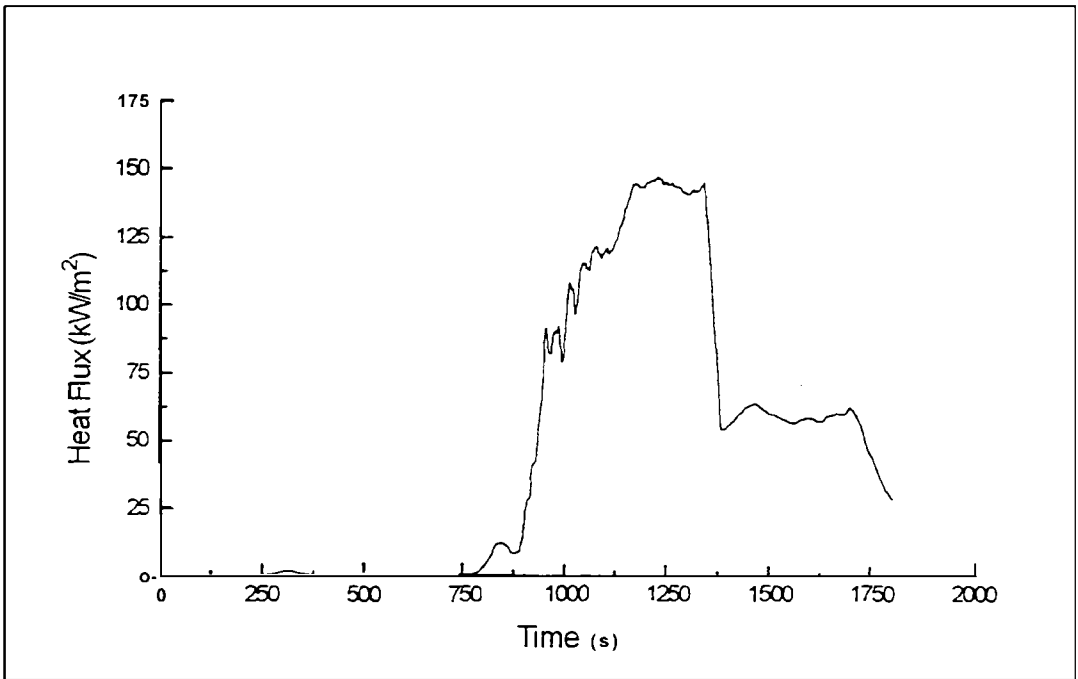

Figure FO2-5: Total heat flux in the center of the bum room

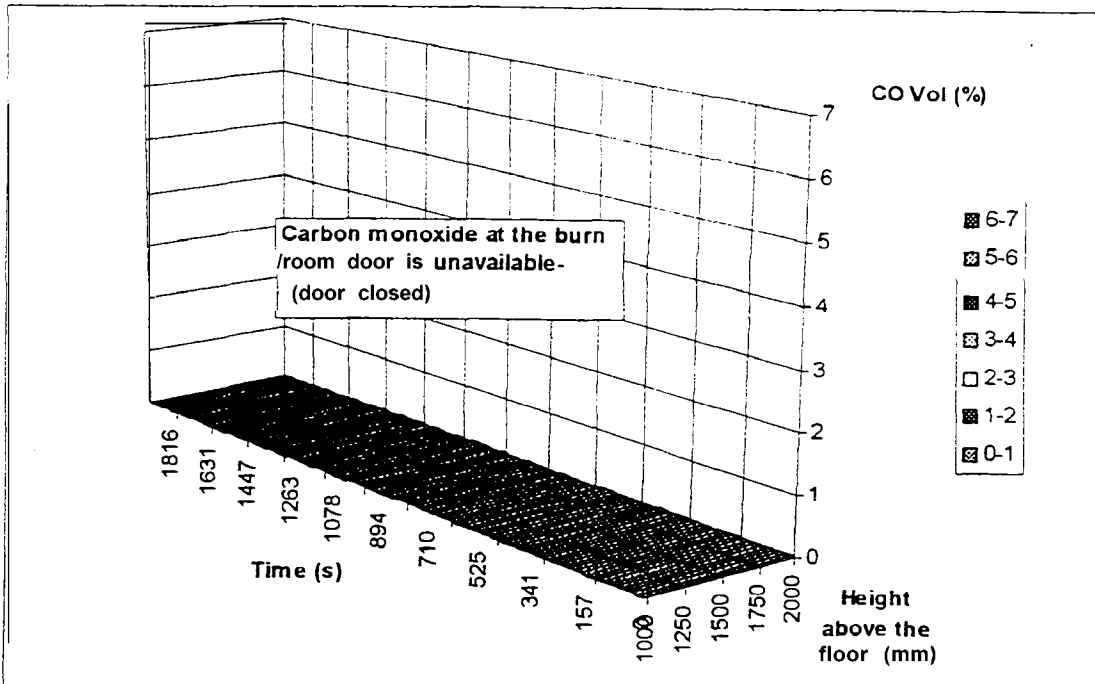

Figure FO2-6: Carbon monoxide concentration along the center line of the bum room door

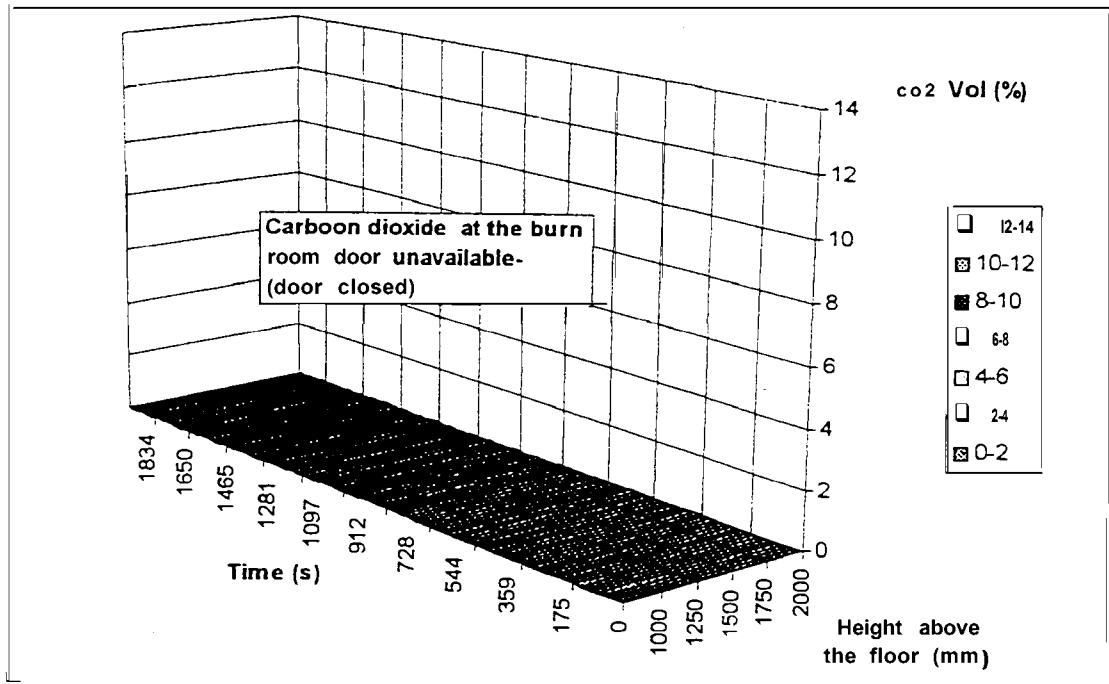

Figure FO2-7: Carbon dioxide concentrations along the center line of the burn room door

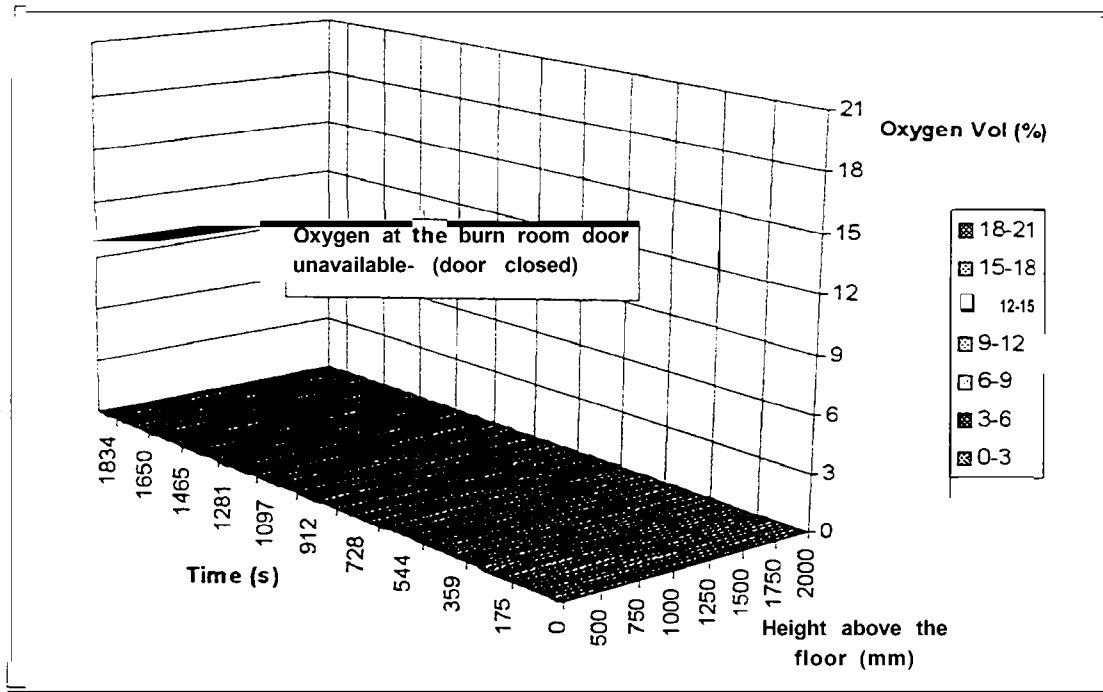

Figure FO2-8: Oxygen concentrations along the center line of the burn room door

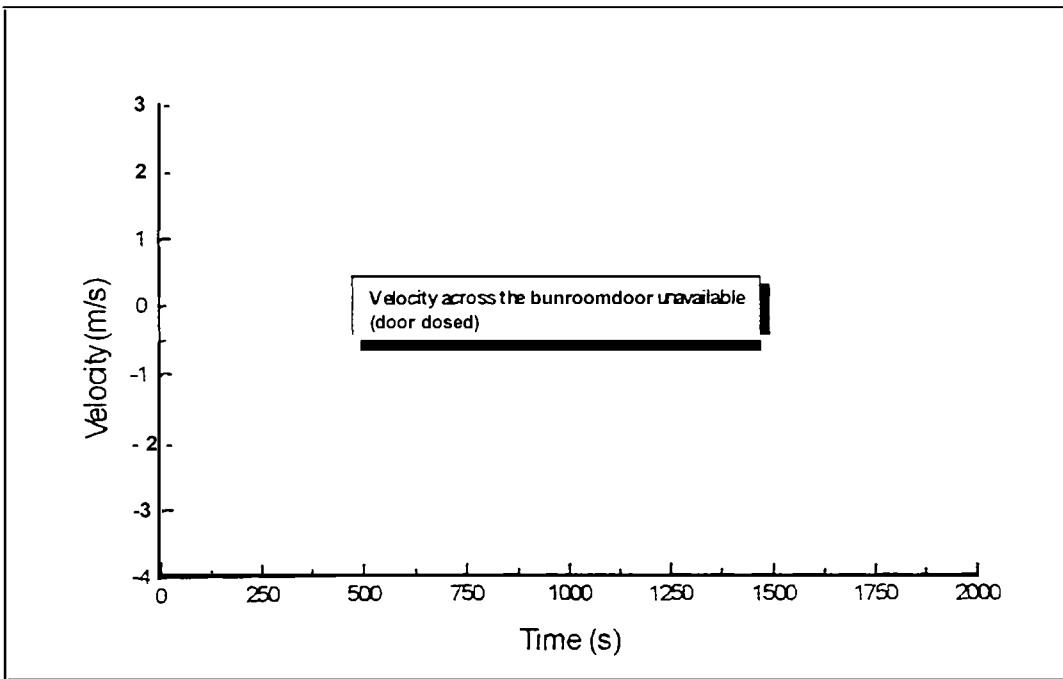

Figure FO2-9: Flow velocity distribution at the center line of the bum room door

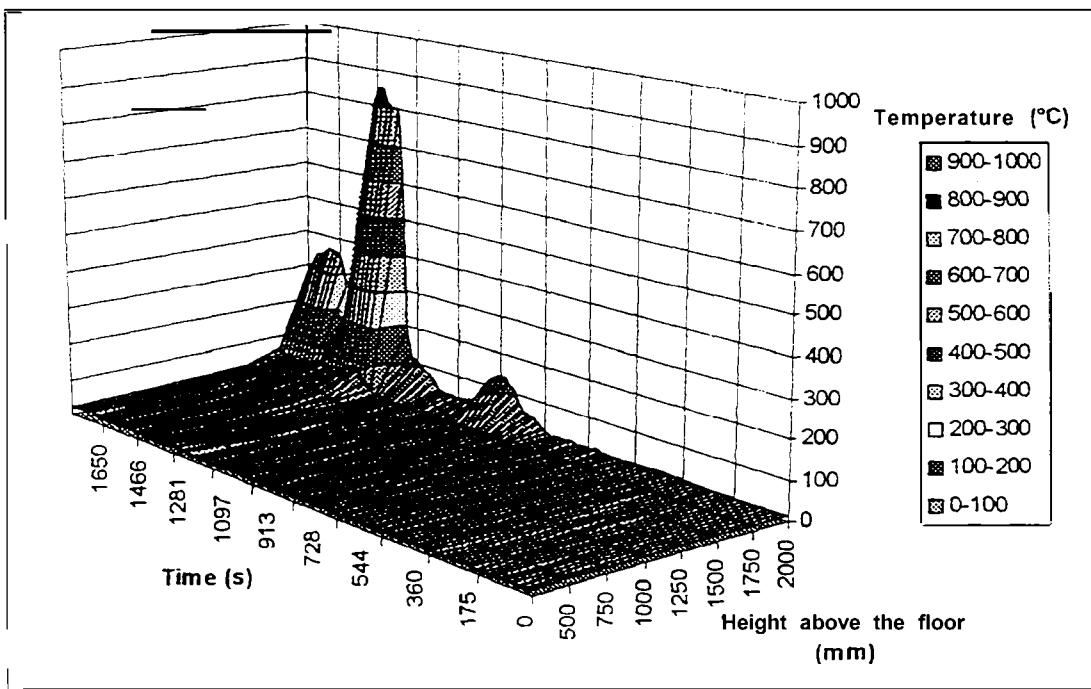

Figure FO2-10: Temperature distribution along the center line of the bum room door

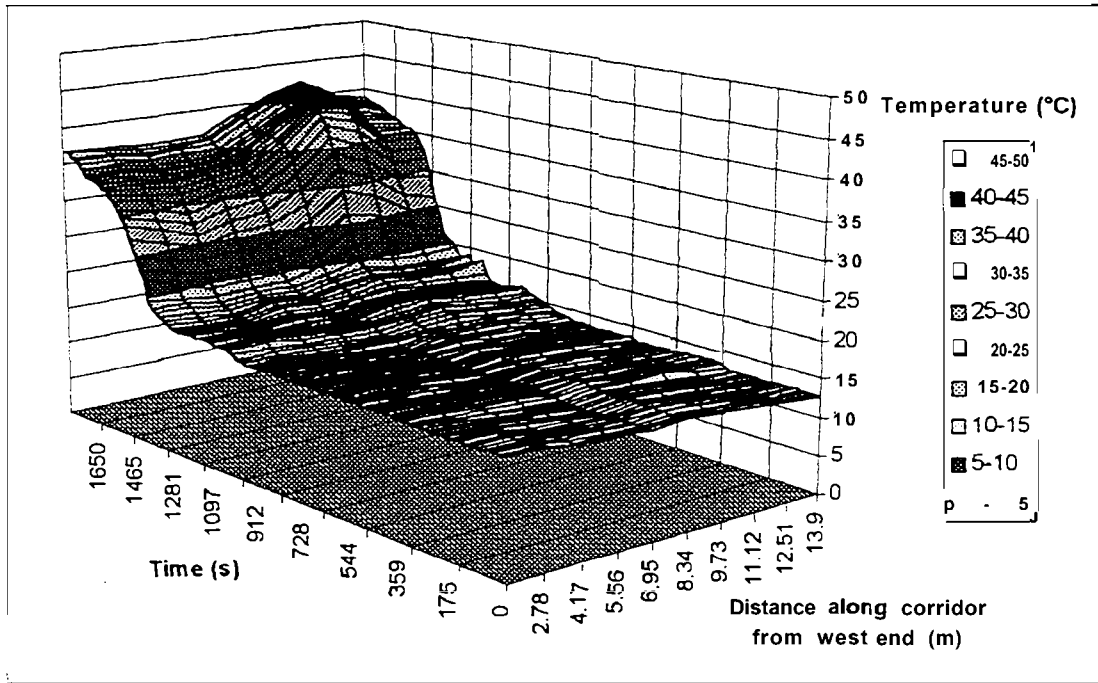

Figure FO2- 11: Temperature along Level 1 corridor (2.0 m above the floor)

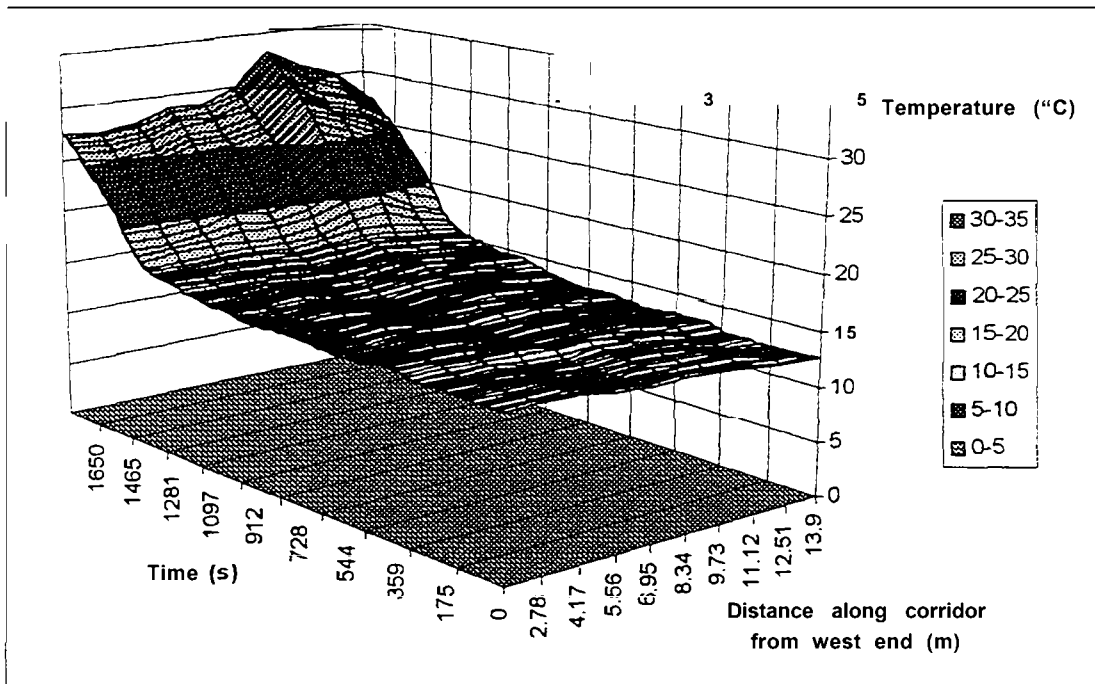

Figure FO2-12: Temperature along Level 1 corridor (1.5 m above the floor)



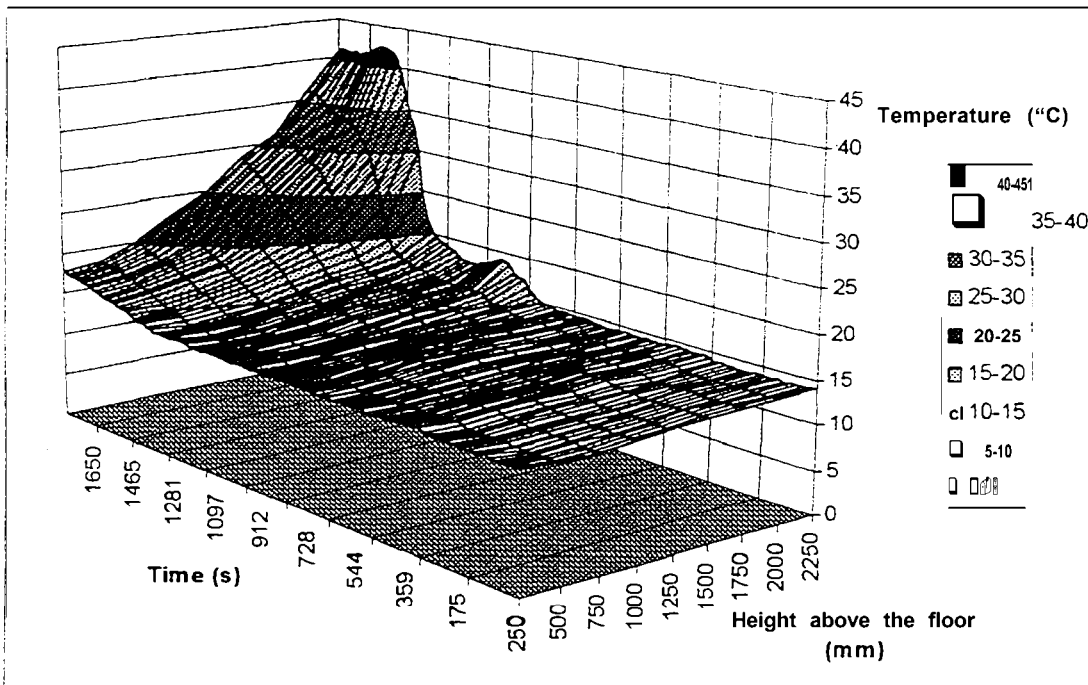
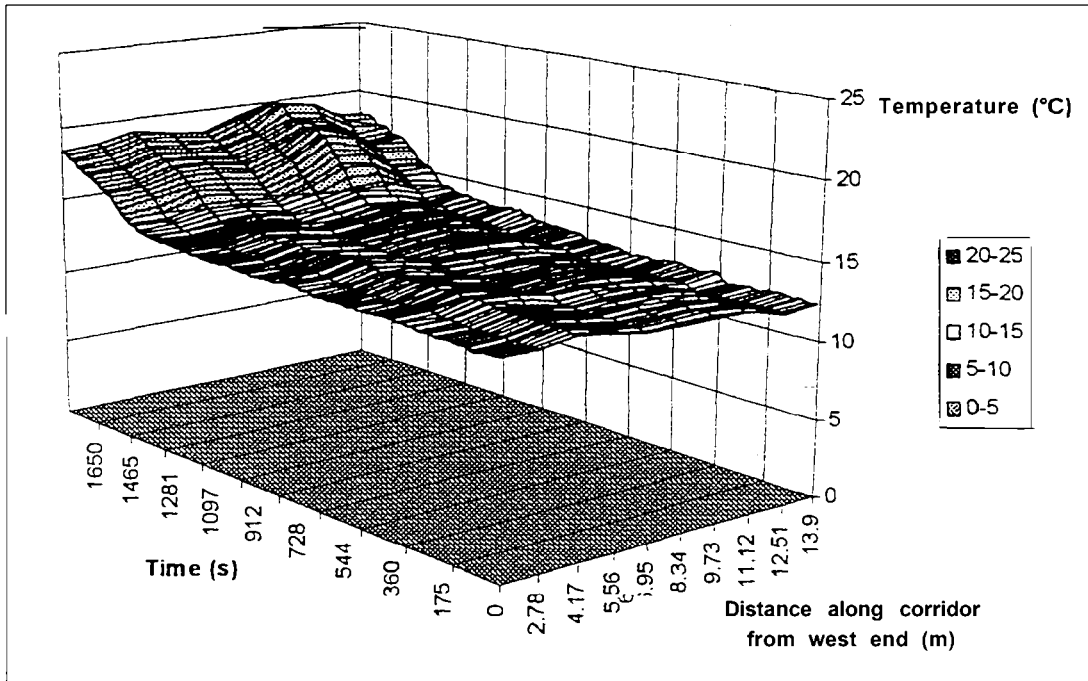

Figure FO2- 14: Vertical temperature distribution in the center of Level 1 corridor

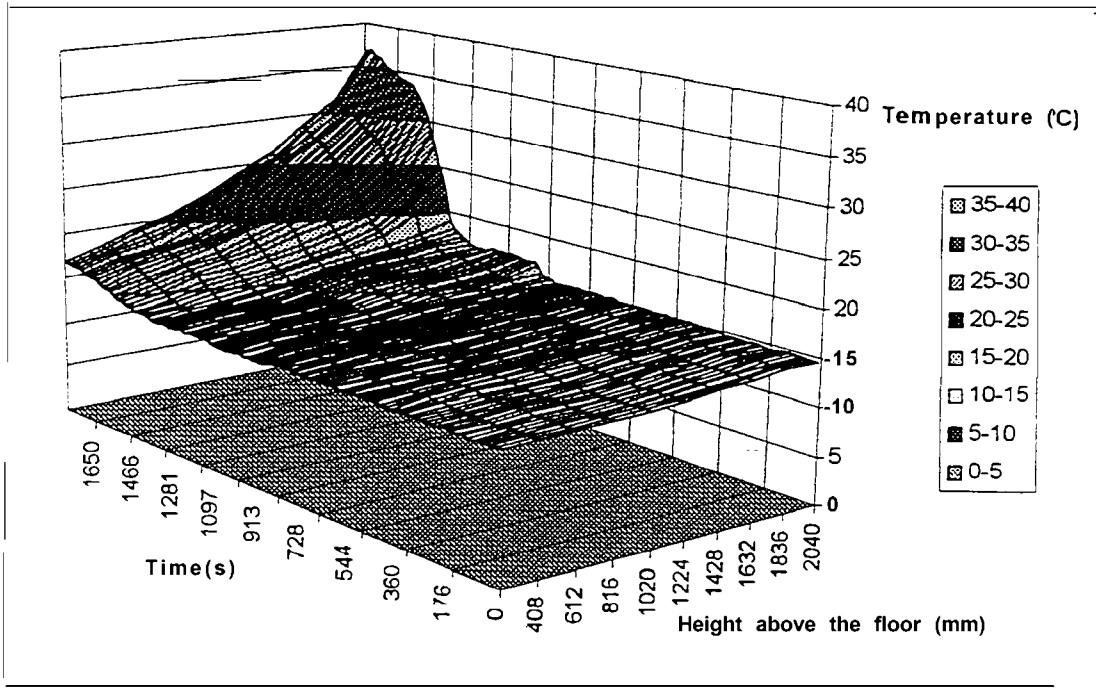

Figure FO2-15: Temperature distribution along the center line of Level 1 stairwell door

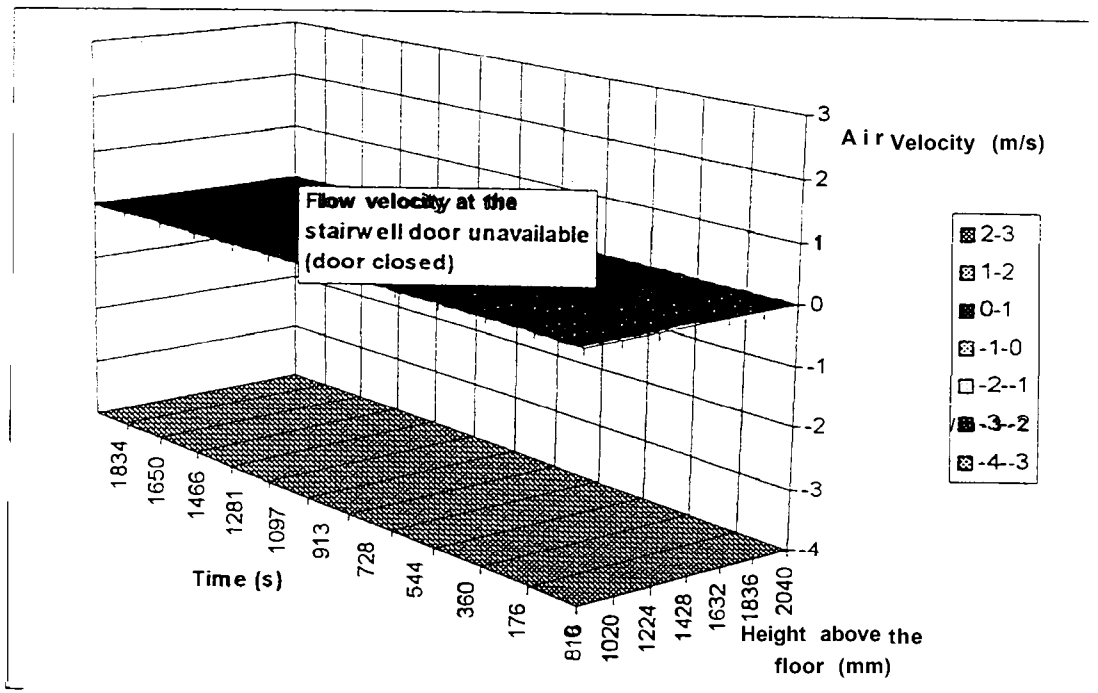

Figure FO2-16: Flow velocity distribution at the center line of Level 1 stairwell door

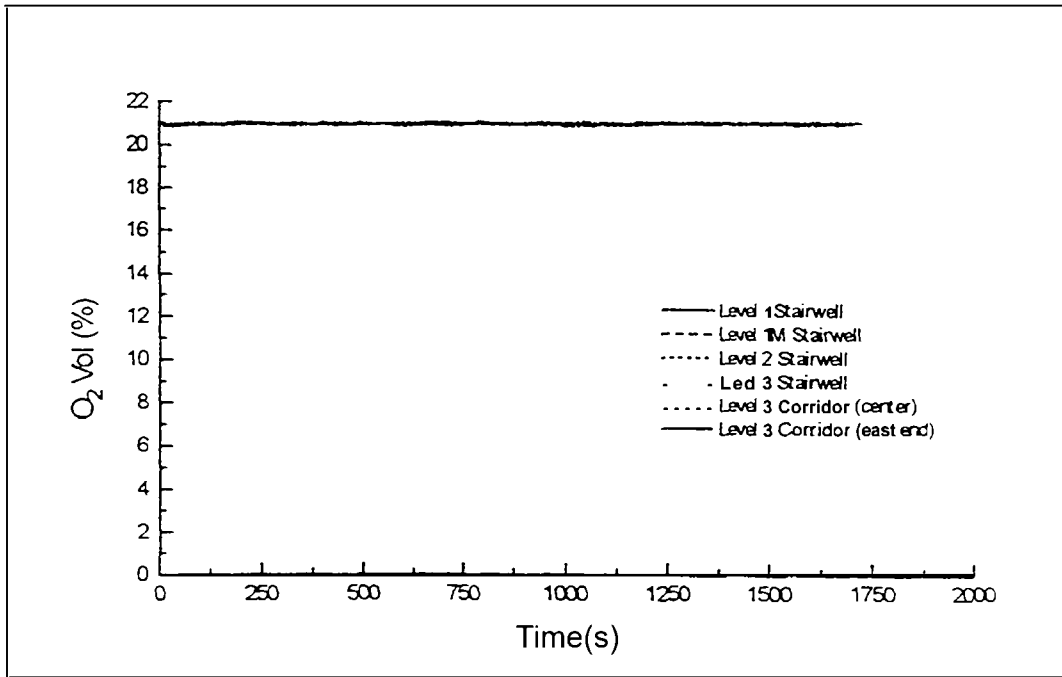

Figure FO2- 17: Oxygen concentration at the stairwell doors (1.7 m above the floor)

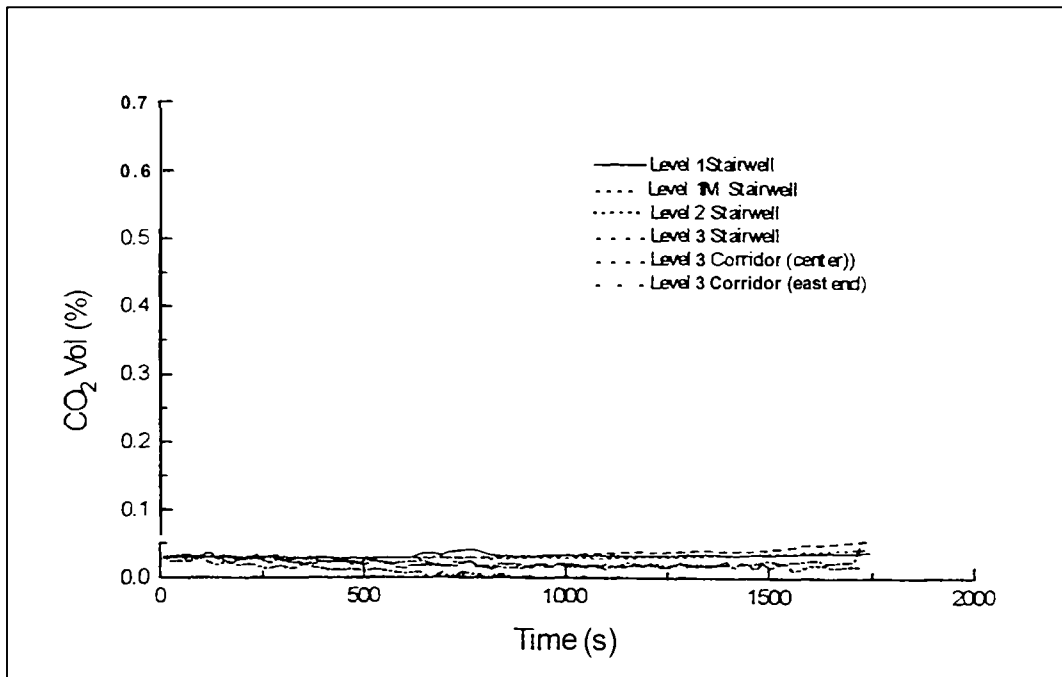

Figure FO2-18: Carbon dioxide concentration at the stairwell doors (1.7 m above the floor)

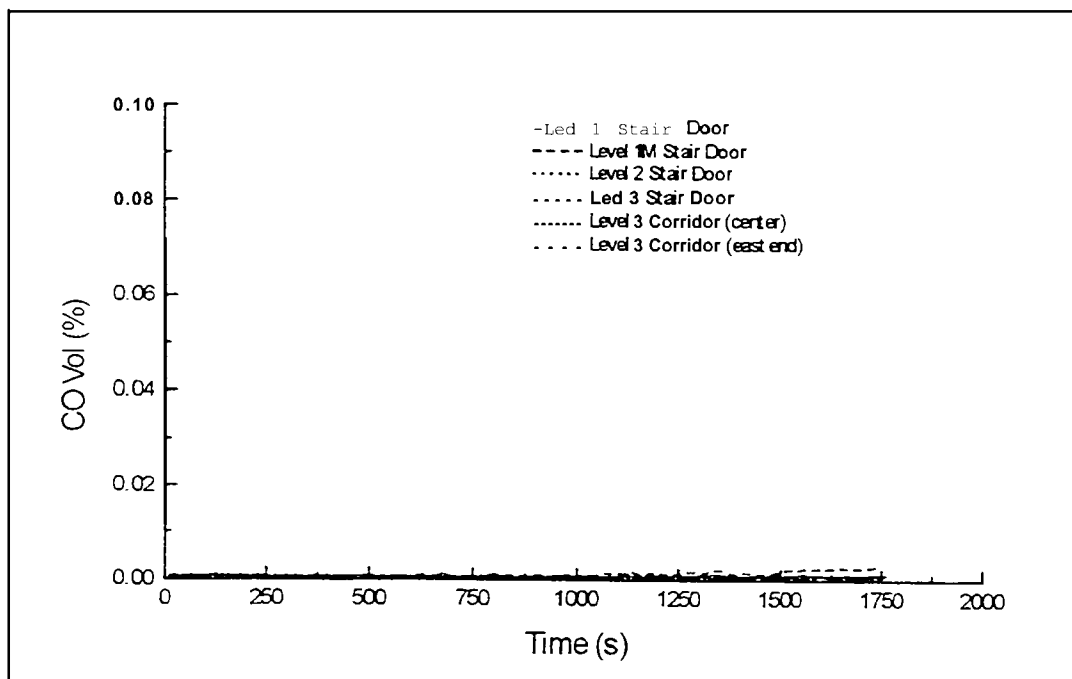

Figure FO2-19: Carbon monoxide concentration at the stairwell doors (1.7 m above the floor)

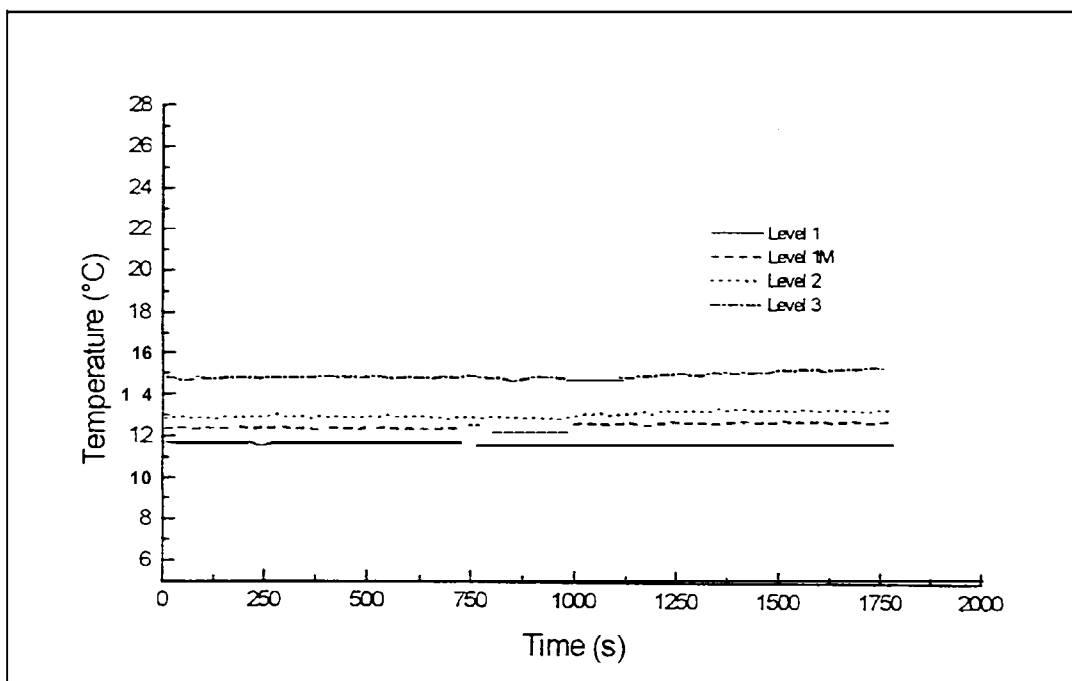

Figure FO2-20: Temperature in the stairwell at each level -North side (1.7 m above the floor)

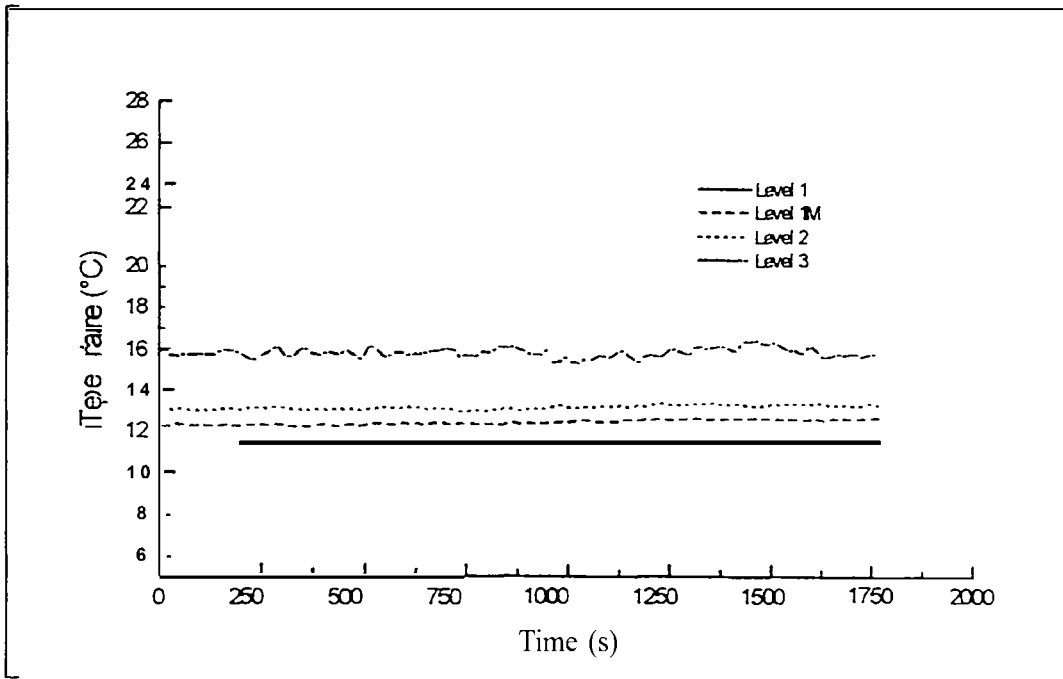

Figure FO2-21: Temperature in the stairwell at each level-South side (1.7 m above the floor)

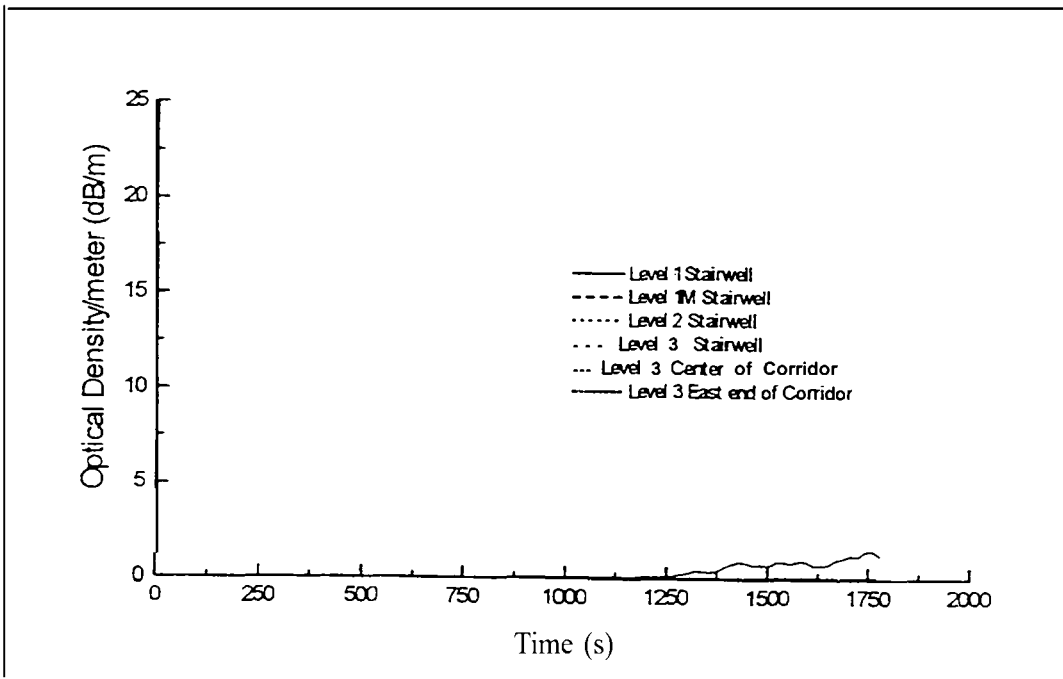

Figure FO2-22: Optical density/m at six locations (1.7 m above the floor)

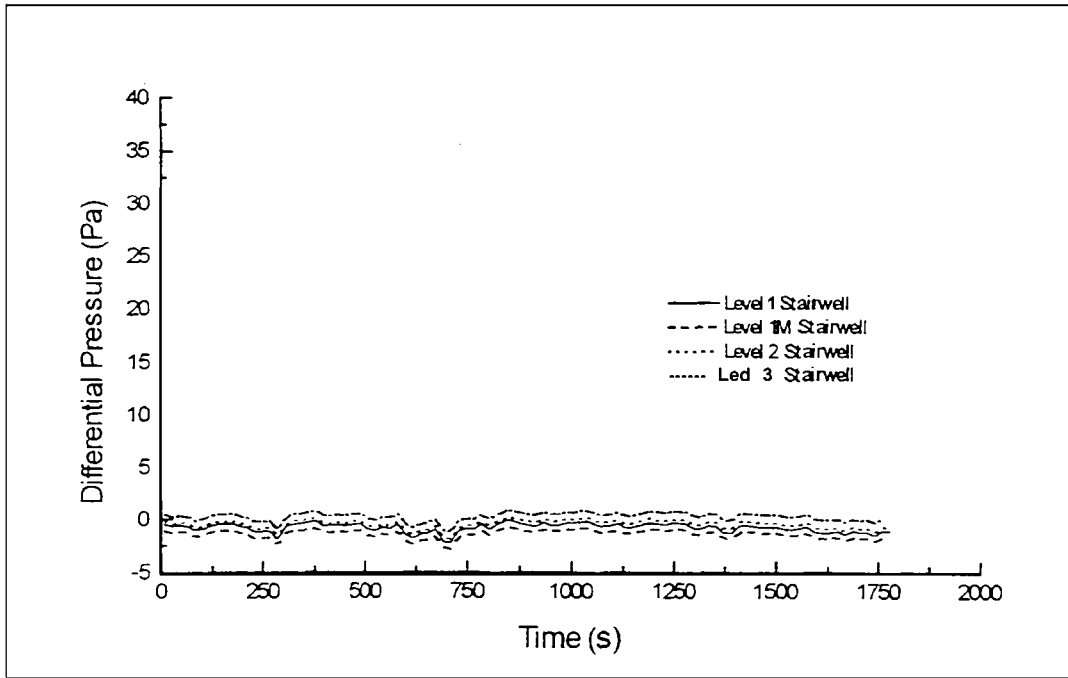

Figure FO2-23: Pressure differences between outside and the stairwell at each level (1.7 m above the floor)

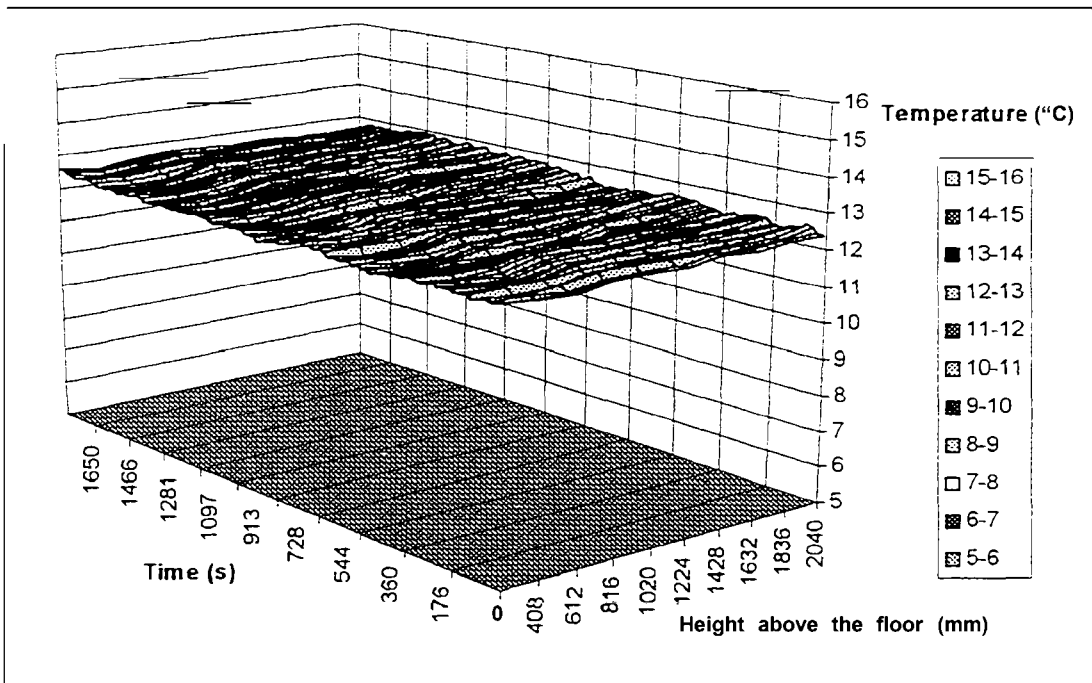

Figure FO2-24: Temperature distribution along the center line of Level 1M stairwell door

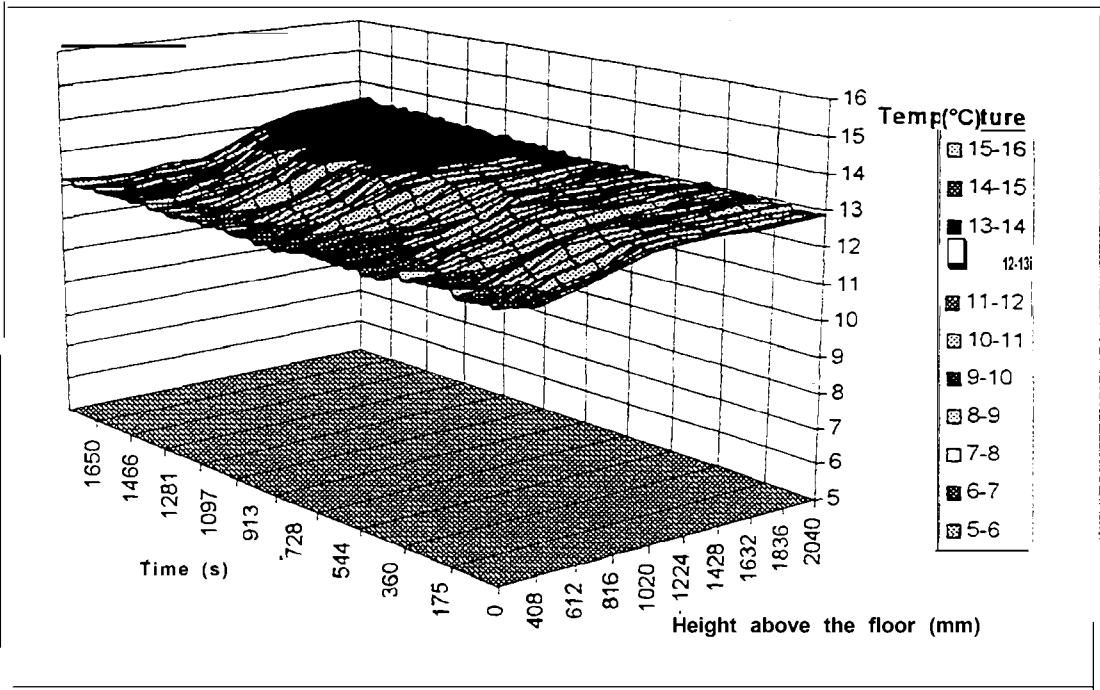

Figure FO2-25: Temperature distribution along the center line of Level 2 stairwell door

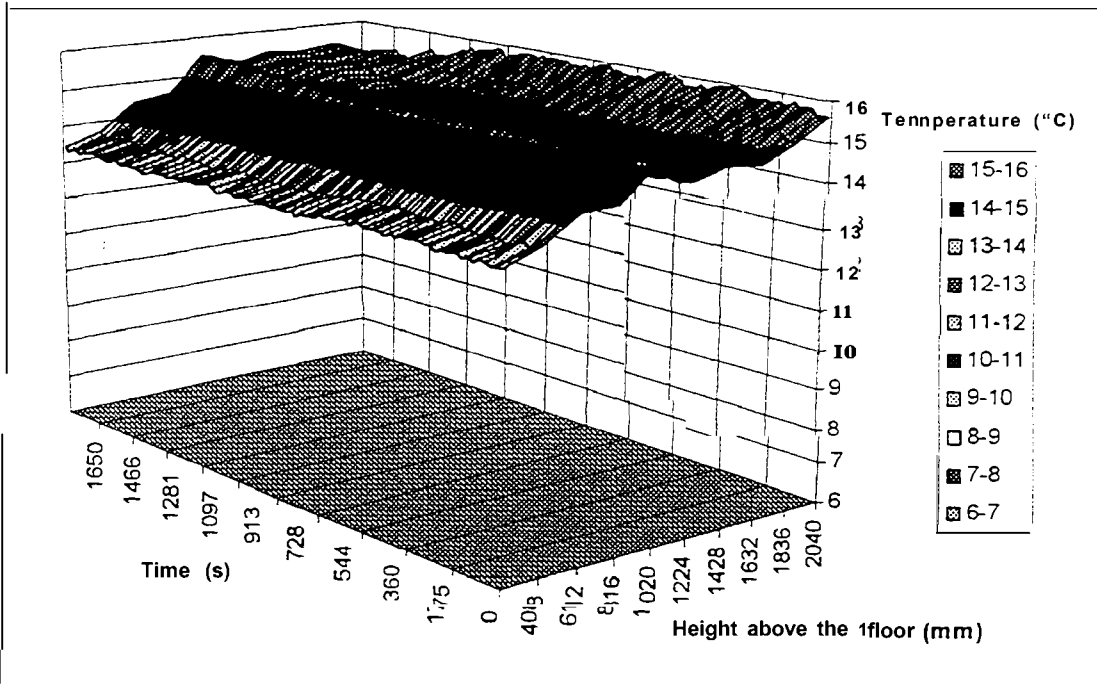

Figure FO2-26: Temperature distribution along the center line of Level 3 stairwell door

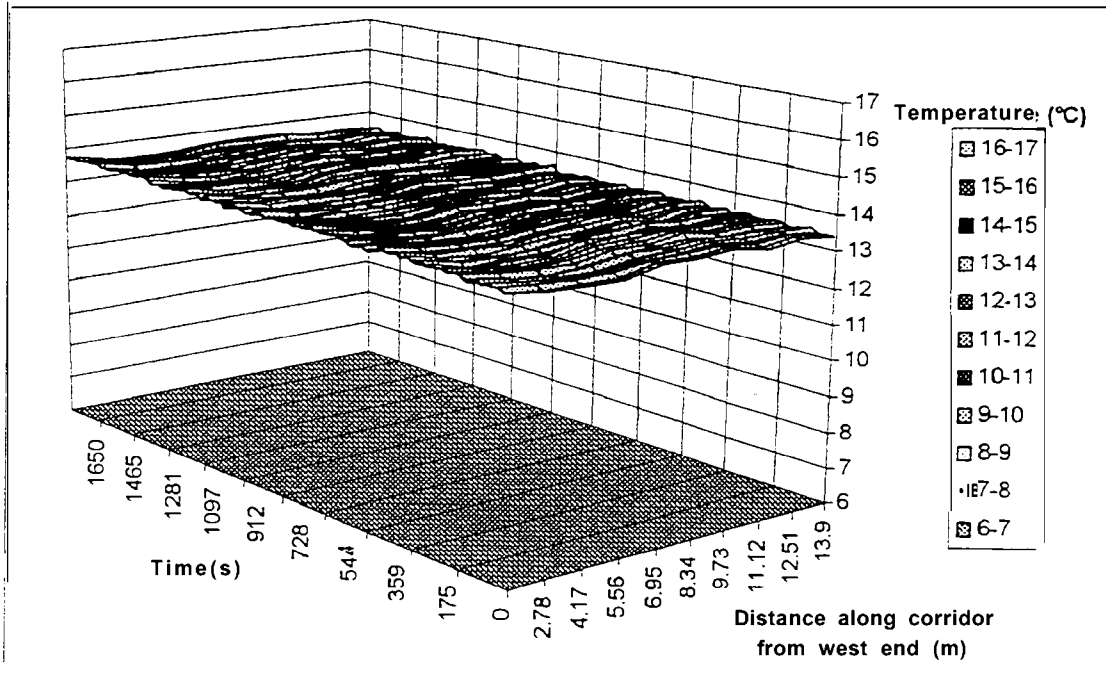

Figure FO2-27: Temperature distribution along Level 1M corridor (1.7 m above the floor)

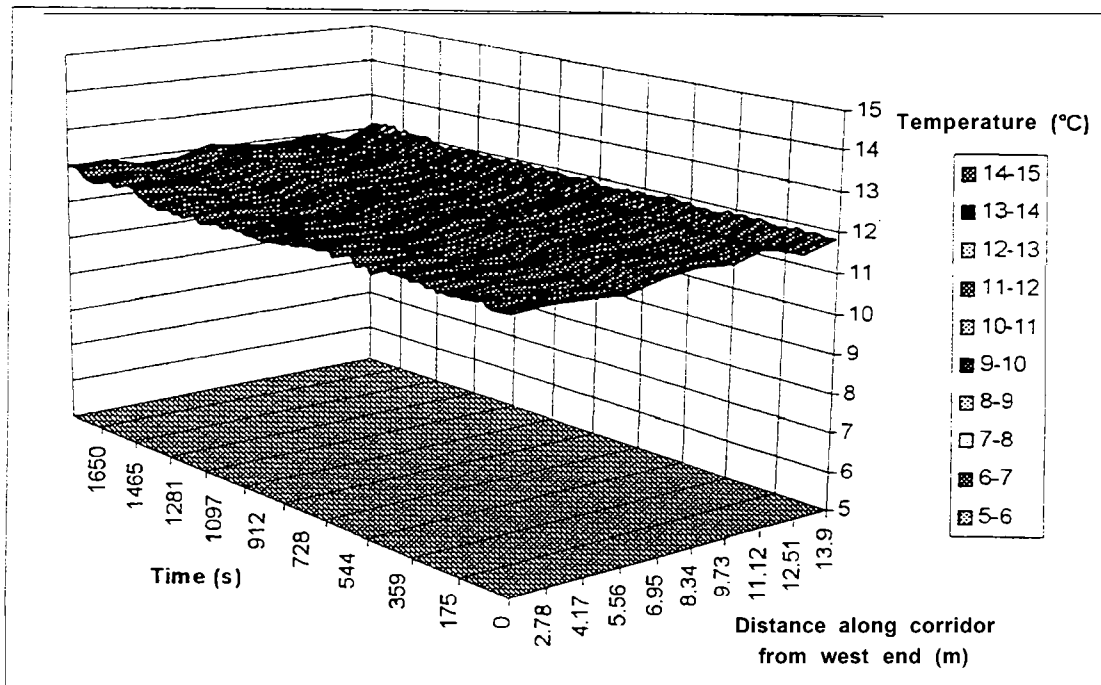

Figure FO2-28: Temperature distribution along Level 2 corridor (1.7 m above the floor)



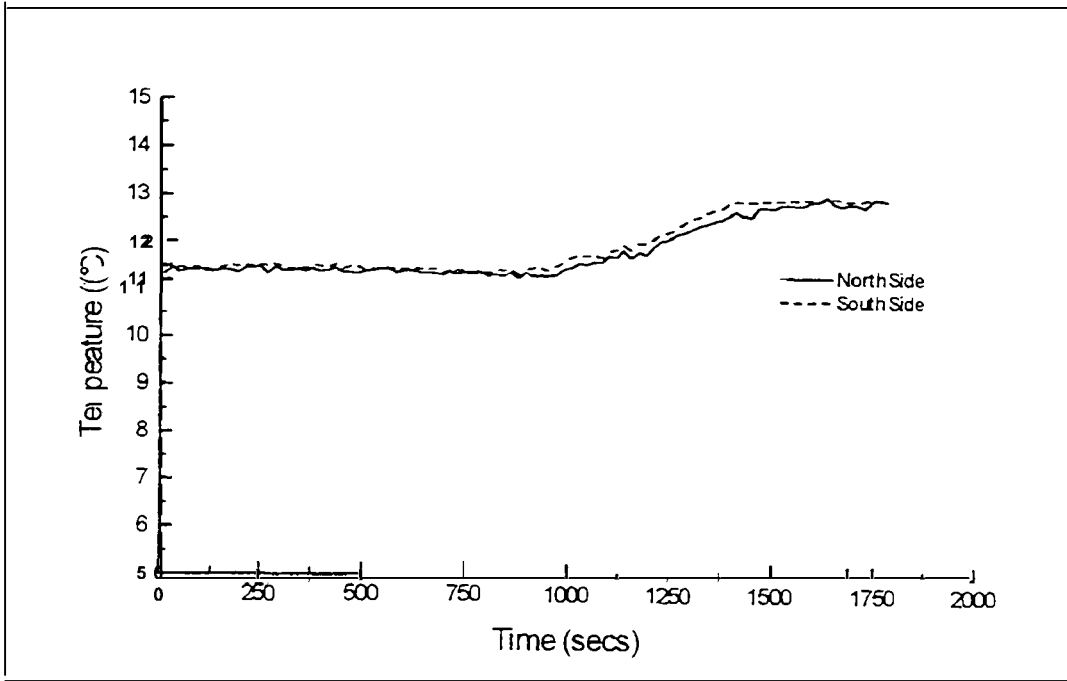

Figure FO2-29: Temperatures in Room 20 1 (1.7 m high)

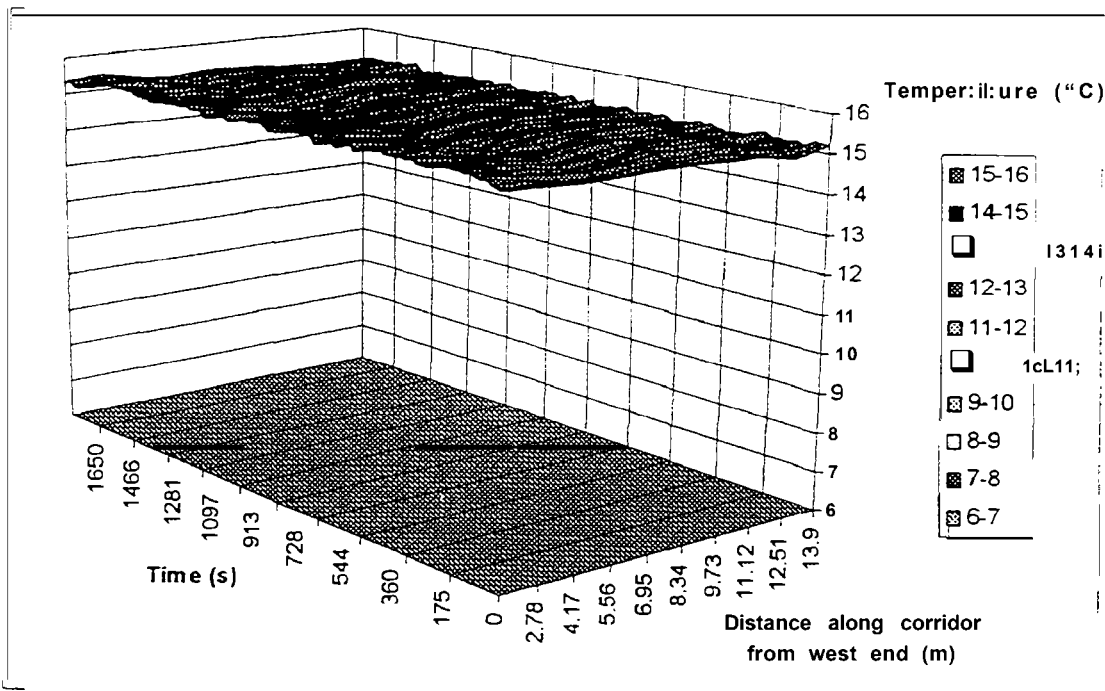

Figure FO2-30: Temperature distribution along Level 3 corridor (1.7 m above the floor)

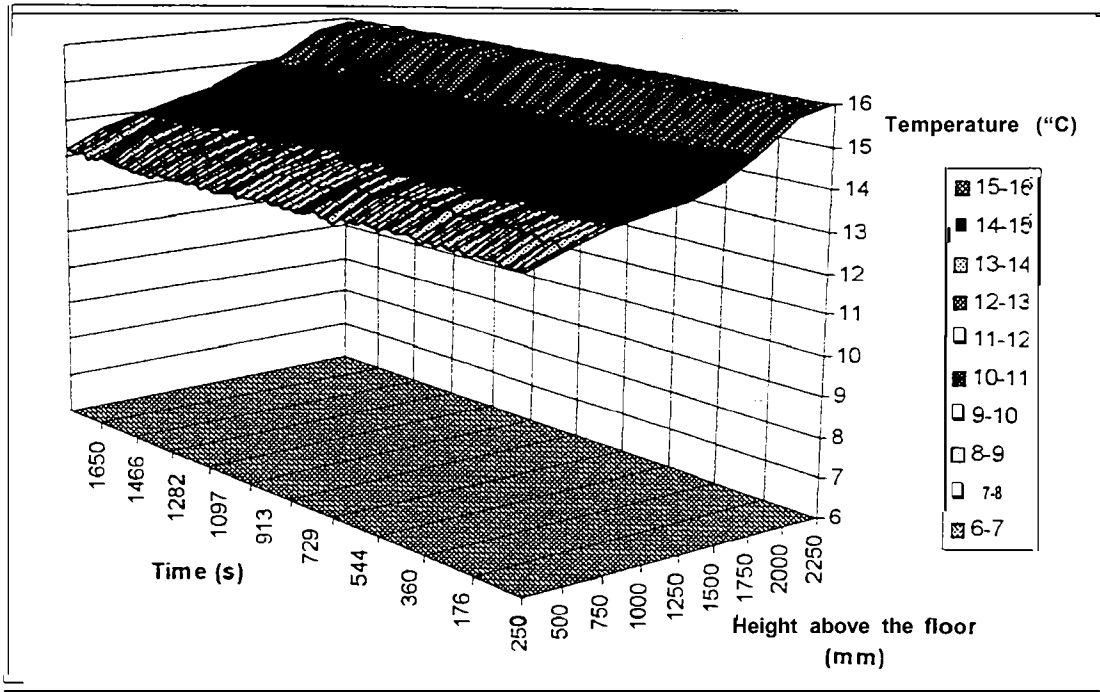

Figure FO2-31: Vertical temperature distribution in the center of Level 3 corridor

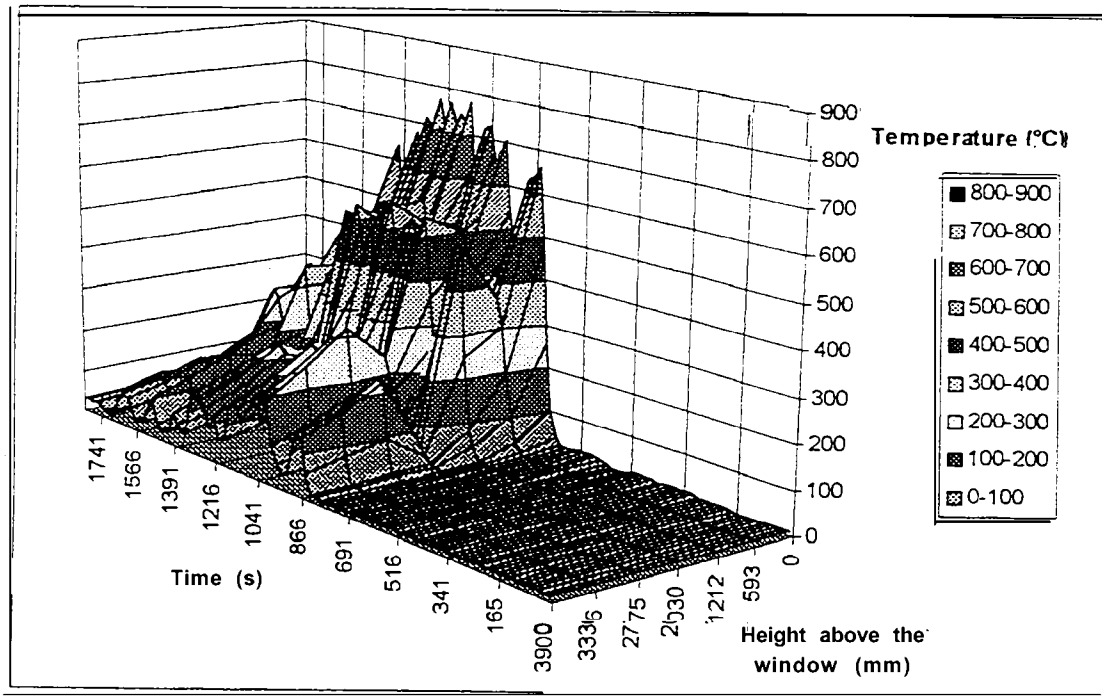

Figure FO2-32: External temperature along the center line of the bum room window (0.02 m from the wall)

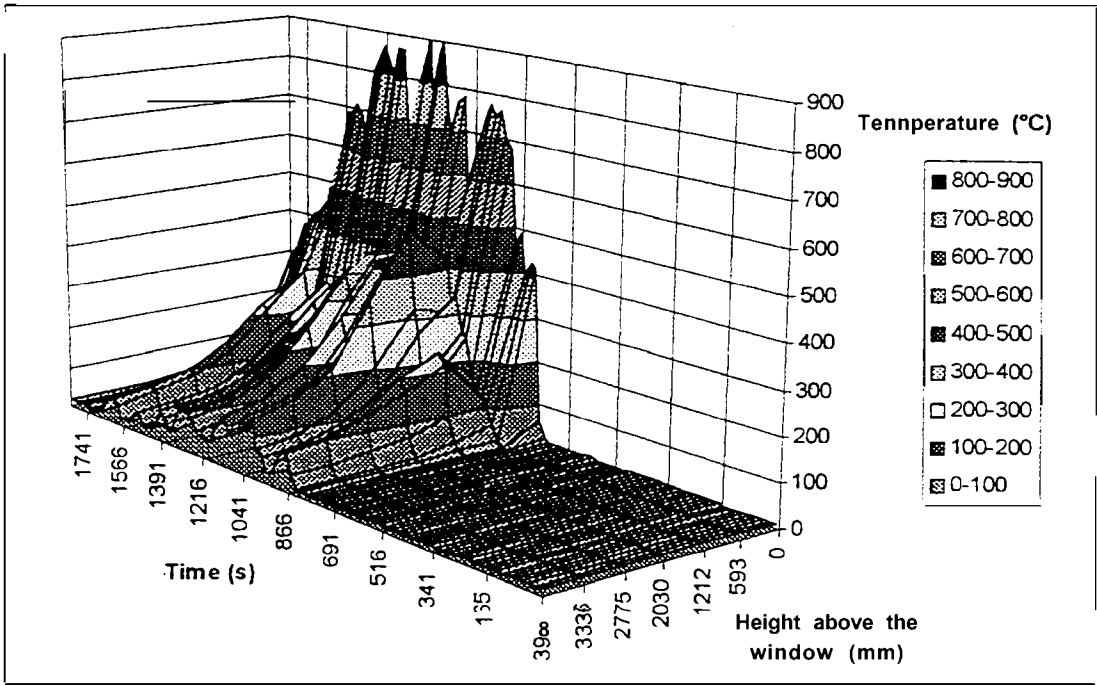

Figure FO2-33: External temperature along the center line of the bum room window (0.5 m from the wall)

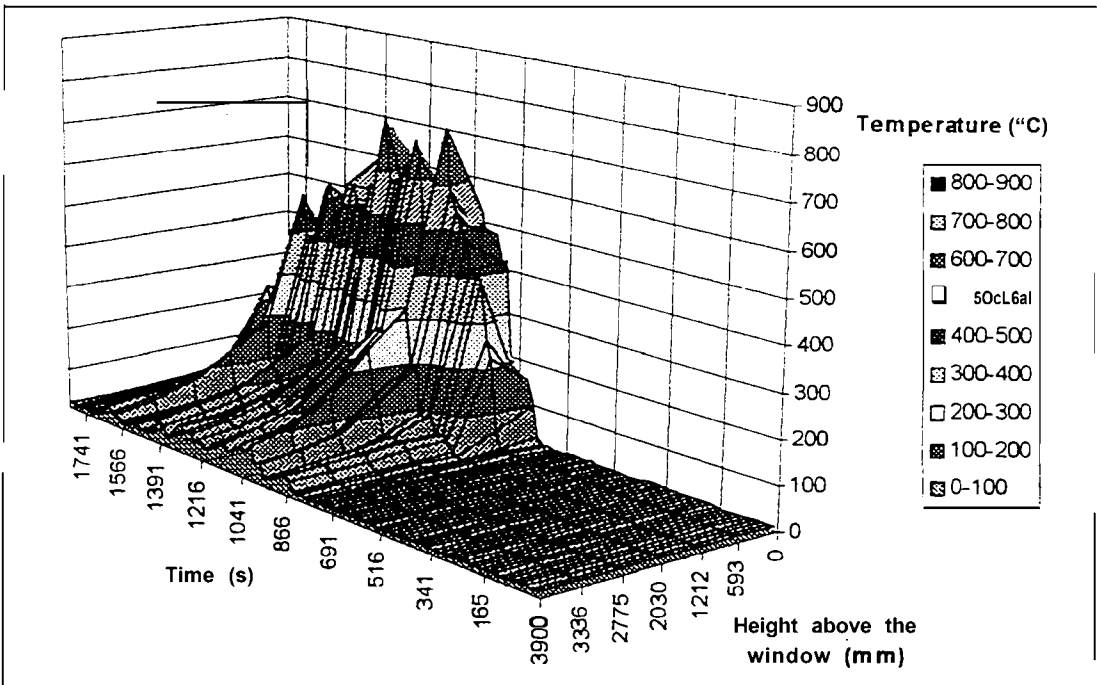

Figure FO2-34: External temperature along the center line of the bum room window (1.0 m from the wall)

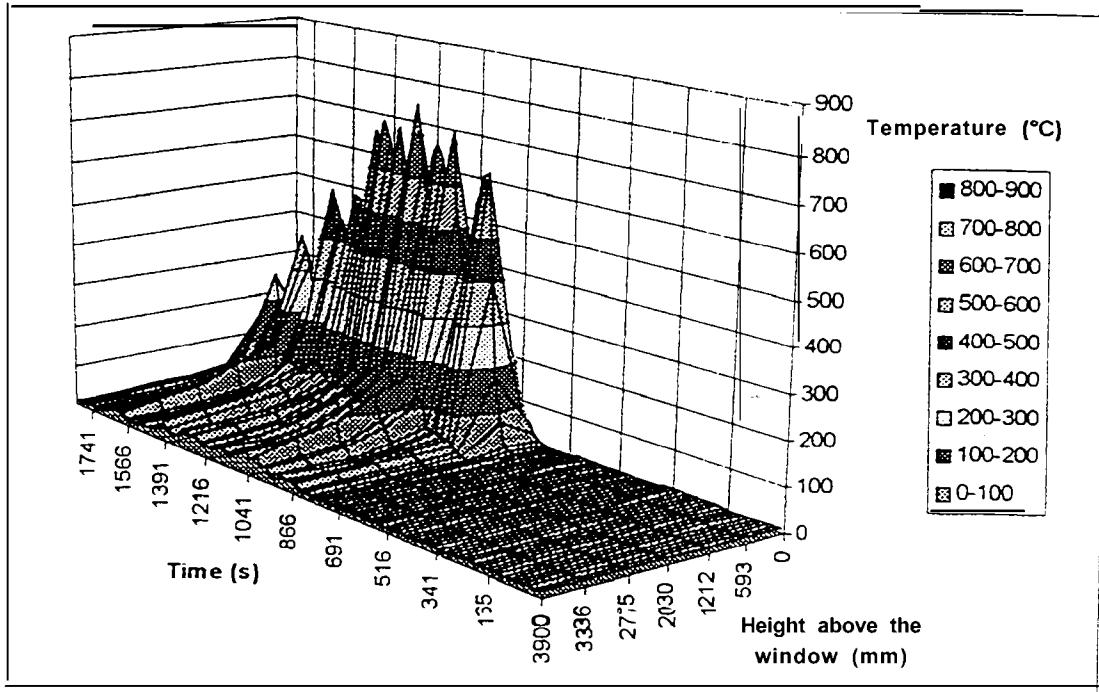

Figure FO2-35: External temperature along the center line of the bum room window (1.5 m from the wall)

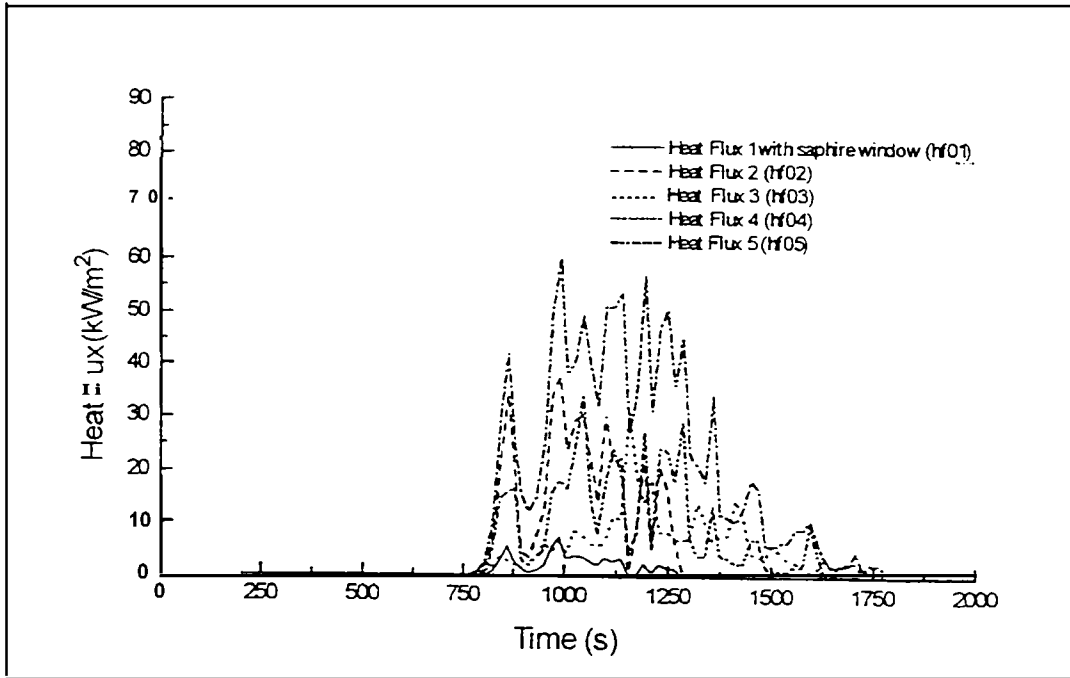

Figure FO2-36: External heat flux measurements (Refer to Figure 25 for locations)

## 11. Flashover Test FO3 (Repeat of FO2)

**Test Conditions:**     **Bum Room Door Closed**  
                               **Level 1 Stairwell Door Closed**

### Observations:

0:00 Ignition  
 0:55 Ionisation detector activated  
 3:50 Sprinkler above the small platform activated (detection only)  
 4:20 Sprinkler above the large platform activated (detection only)  
 4:30 Smoke layer to floor level  
 4:55 Initial crack in middle pane  
 9:35 ***Initial part of test declared finished***  
       Window lowered  
 10:35 Flames 0.5 m high above the window opening  
 12:50 Level 1M window cracked  
 13 :00 Flashover occurs  
 13:20 Initial dislodgment of Level 1M window  
 14:30 Flames 2.0 m high above the window opening  
 15.20 Remaining glass in middle pane of Level 1M window dislodged  
 17: 15 Remaining glass in 1M window dislodged  
 24:50 Bum room door clearly visible through window opening  
 25 : 10 Top left hand comer of Level 2 window dislodged

As this test was a repeat of fire test F02, the window was lowered at approximately the same time. In this test Level 2 window (W201) also had glass dislodgment. As in F02 the sprinkler in Level 1 corridor did not activate. The P/U and the carpet in Level 1 corridor were unaffected. The results of F02 and F03 for the bum room are compared in Section 17.1.1.

**Table 9: Summary of results for Test F03**

<b>In the Burn Room</b>	
Maximum Heat Release Rate	11.29 MW
Maximum Peak Temperature	1082 °C
Maximum Average Room Temperature	956 °C
Minimum Oxygen Concentration	0.6 Vol %
Maximum Total Heat Flux	111 kW/m <sup>2</sup>
Time untenability reached (100°C)	250 s
<b>At the Burn Room Door</b>	
Maximum CO Concentration a	na Vol %
Maximum CO <sub>2</sub> Concentration	na Vol %
Maximum Temperature	116 °C

Minimum Oxygen Concentration	na Vol %
<b>In Level 1 Corridor</b>	
Maximum Temperature 1.5 m above the floor	35 °C
Maximum Temperature in the center of the Corridor	42 °C
<b>Stairwell</b>	
Maximum Temperature	Level 1 13 °C
	Level 1M 14 °C
	Level 2 14 °C
	Level 3 15 °C
<b>Level 3 Corridor</b>	
Maximum Temperature	14 °C
<b>External</b>	
Maximum External Temperature	850 °C
Maximum Total Heat Flux	87.6 kW/m <sup>2</sup>

Note: A full list of detector and sprinkler activation times is shown in Table 15 & 16. Only the time for the first detector activated is listed in the above observations.

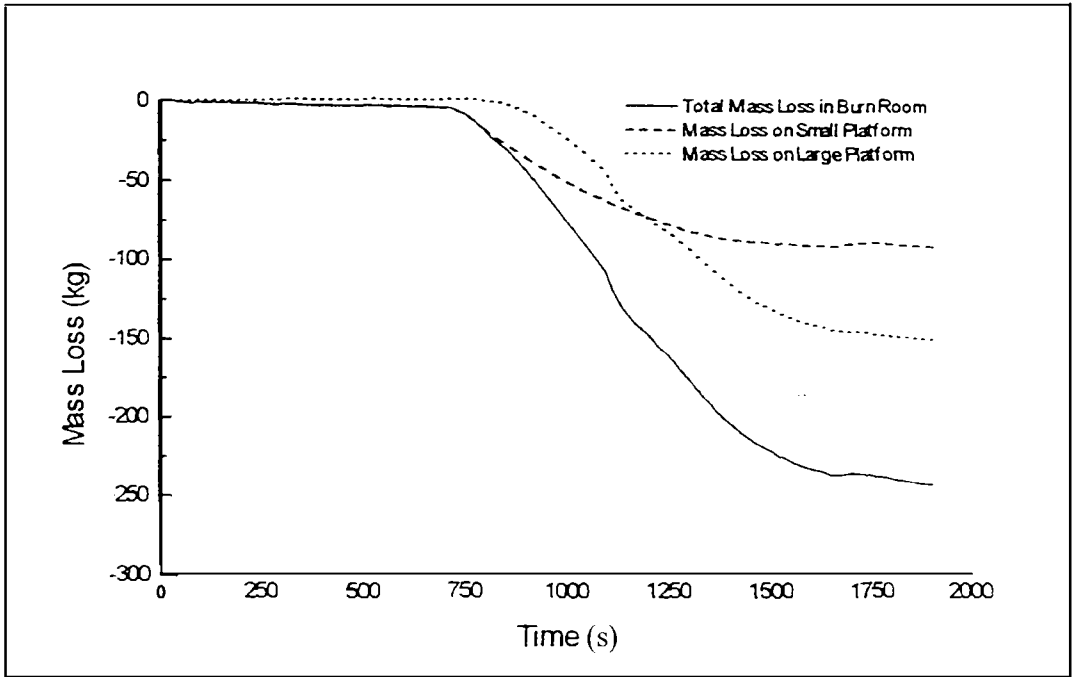

Figure FO3- : Combined mass loss in the bum room

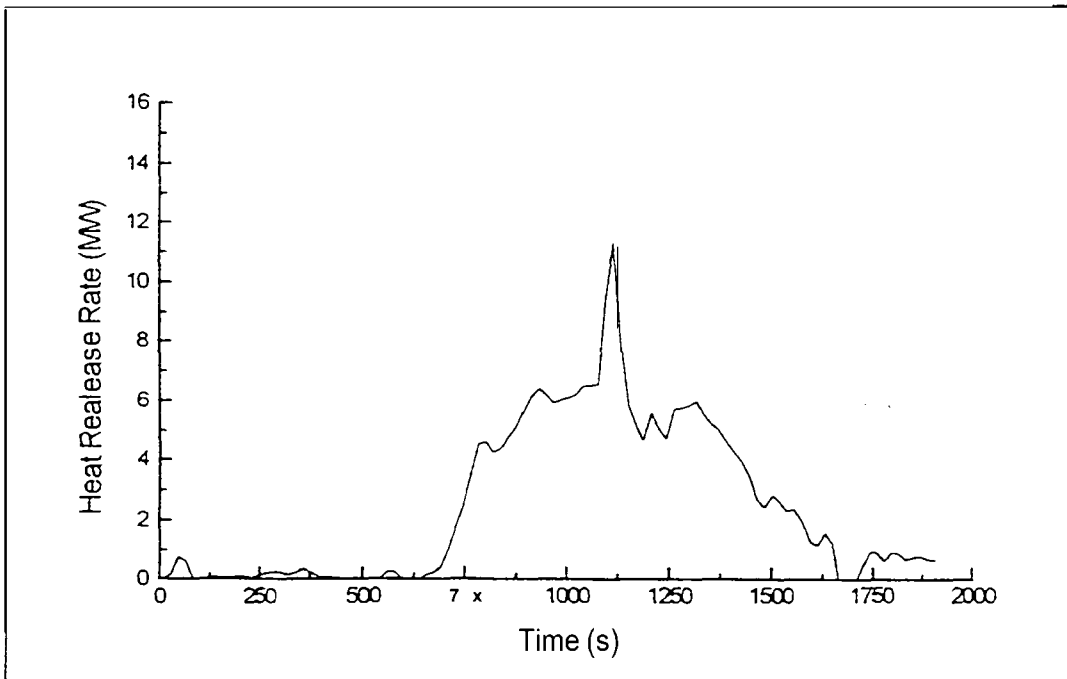

Figure FO3-2: Total heat release rate in the bum room

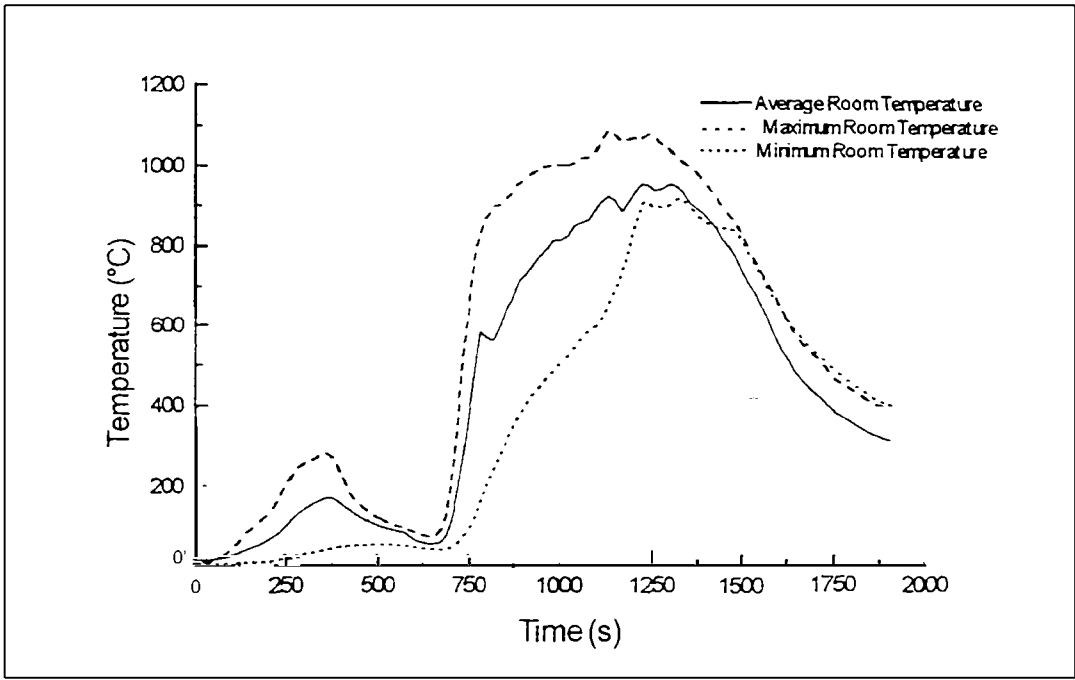

Figure FO3-3: Average, maximum and minimum temperatures in the bum room

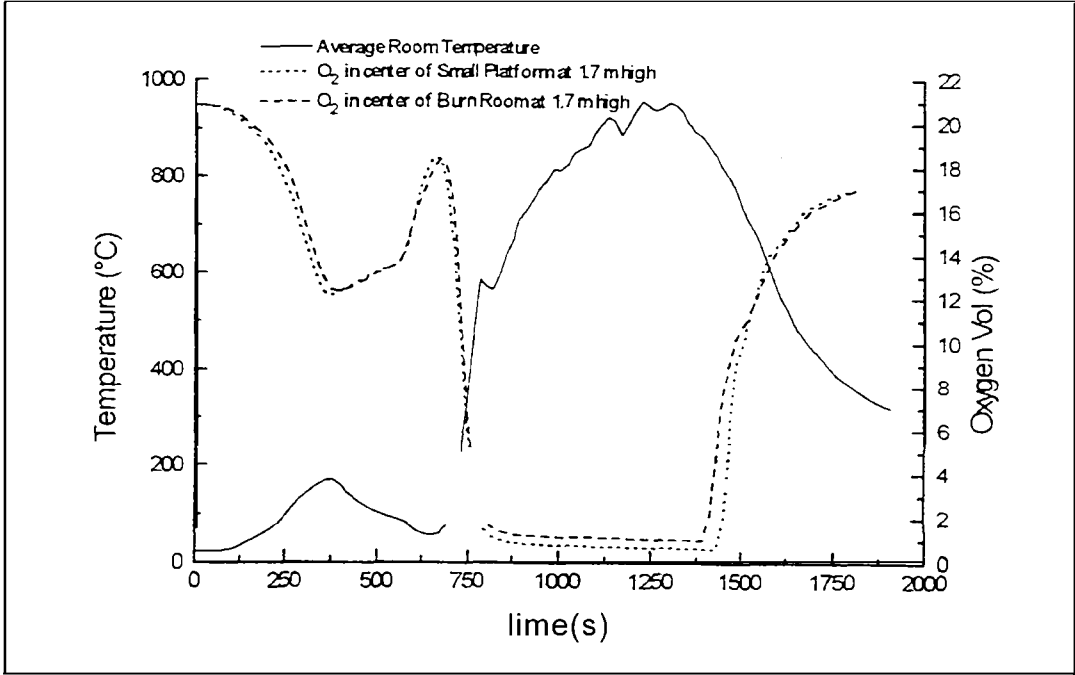

Figure FO3-4: Oxygen concentration and average temperature in the bum room



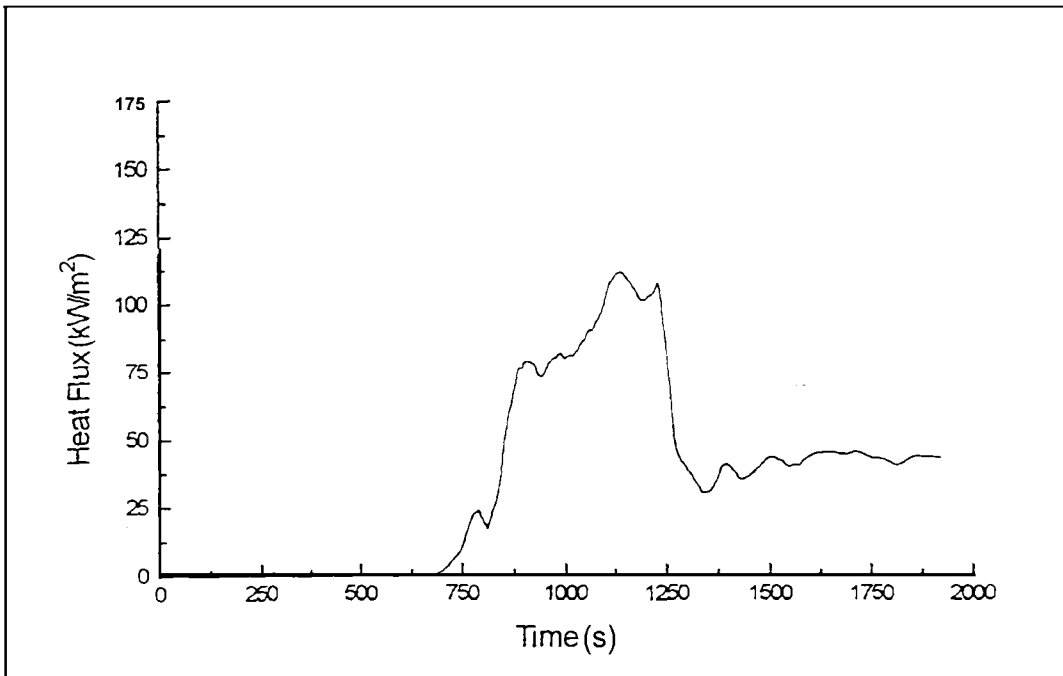

Figure FO3-5: Total heat flux in the center of the bum room

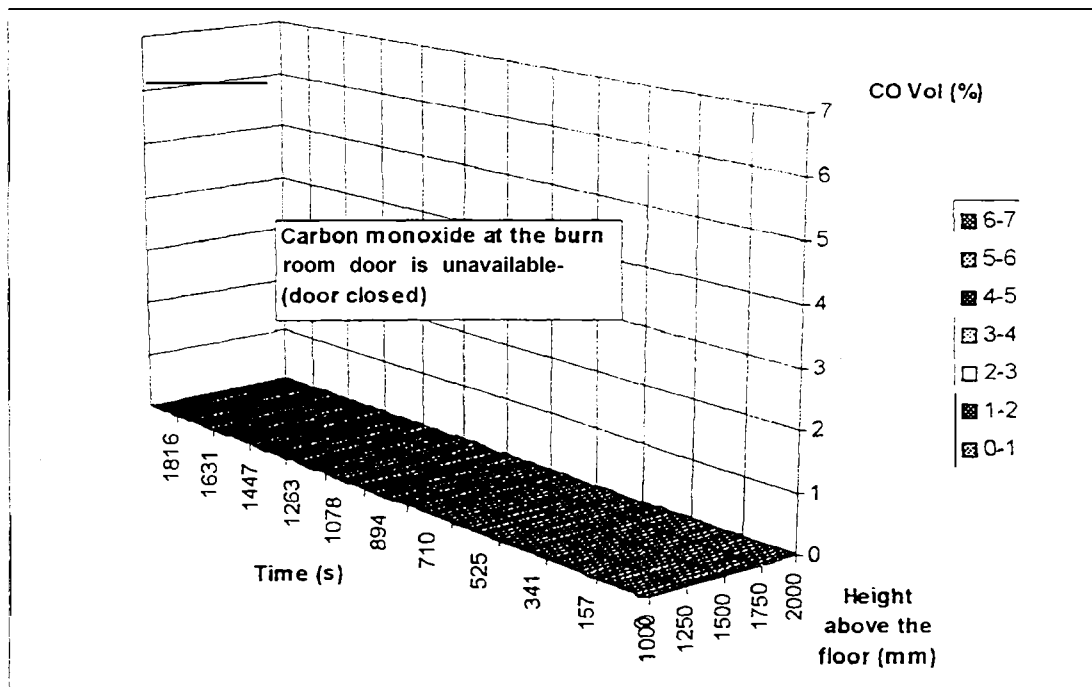

Figure FO3-6: Carbon monoxide concentration along the center line of the bum room door

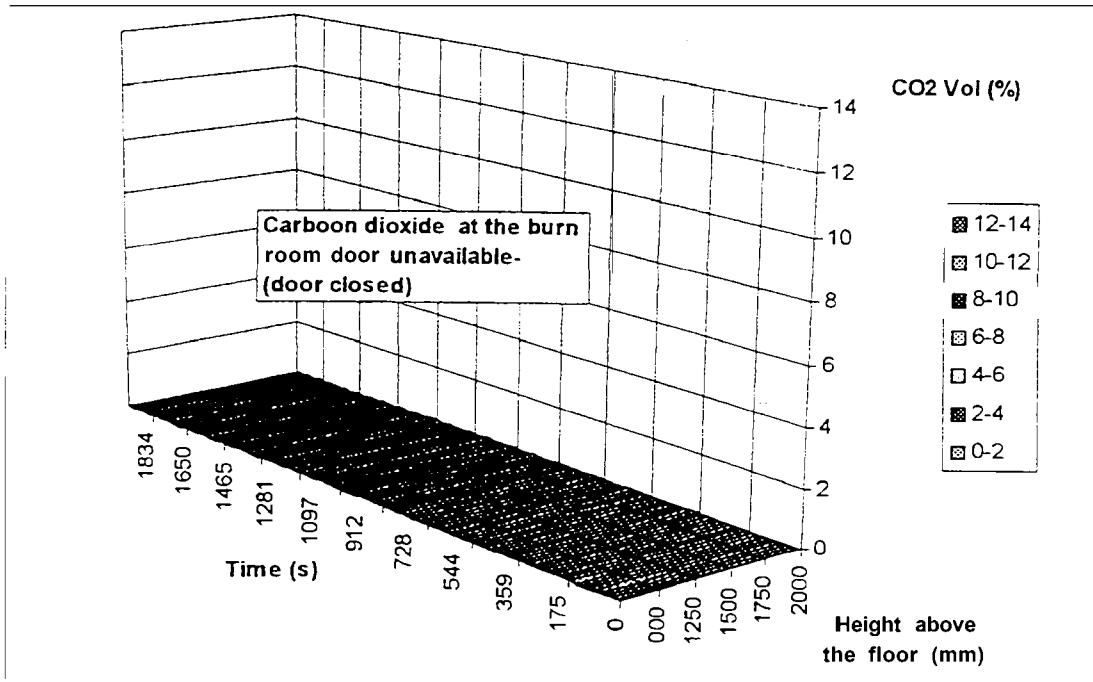

Figure FO3-7: Carbon dioxide concentrations along the center line of the burn room door

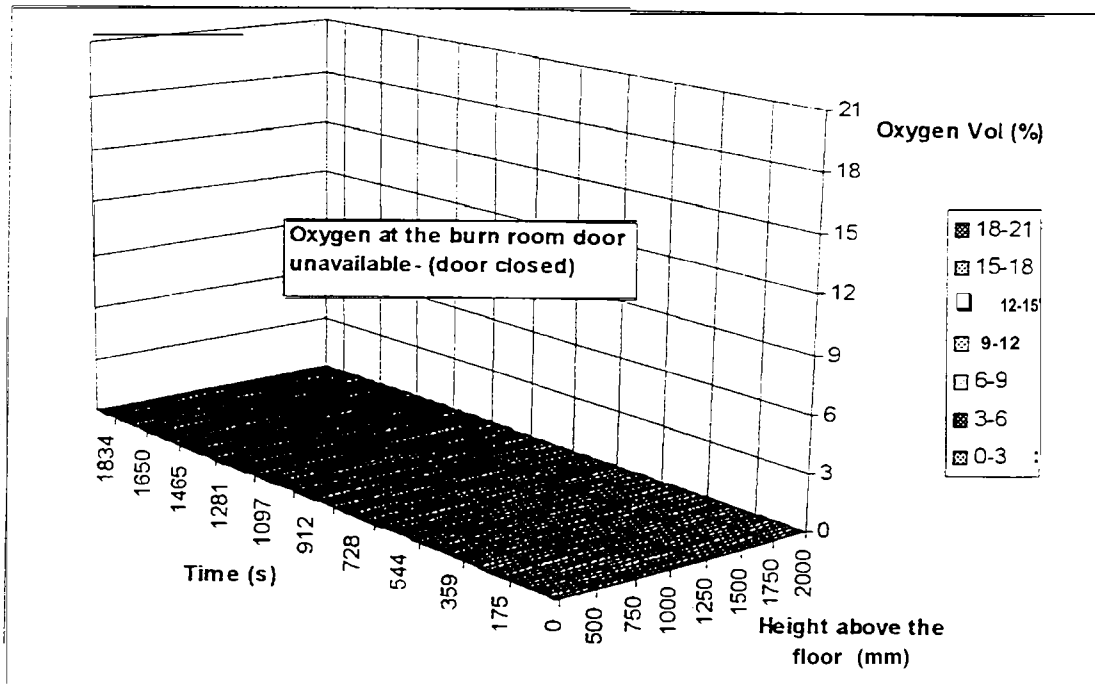

Figure FO3-8: Oxygen concentrations along the center line of the burn room door

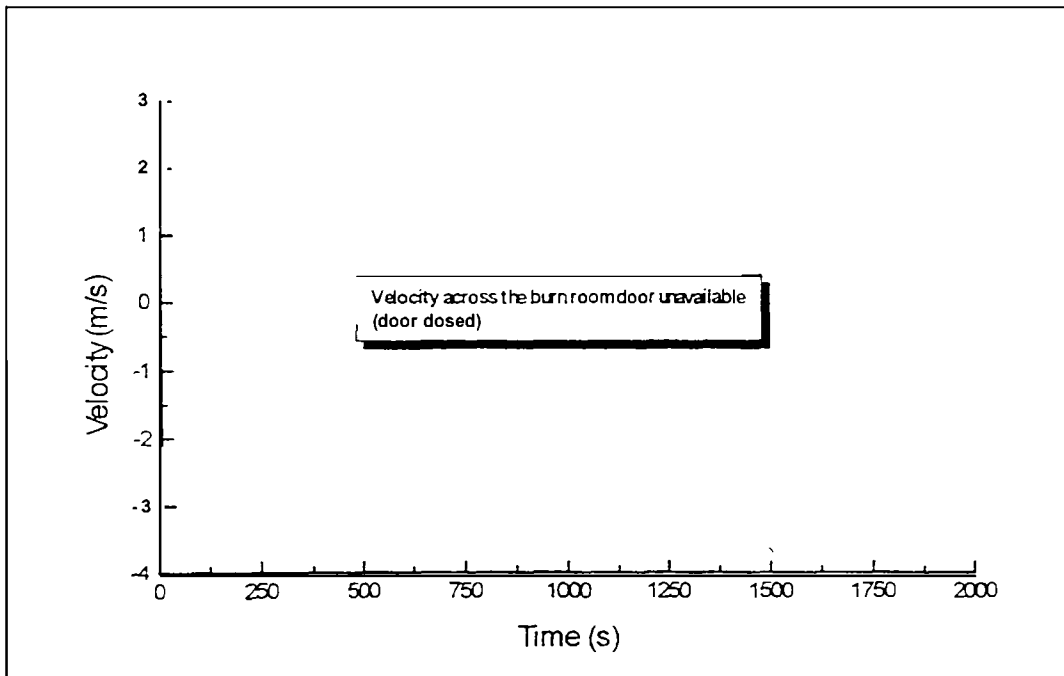

Figure FO3-9: Flow velocity distribution at the center line of the bum room door

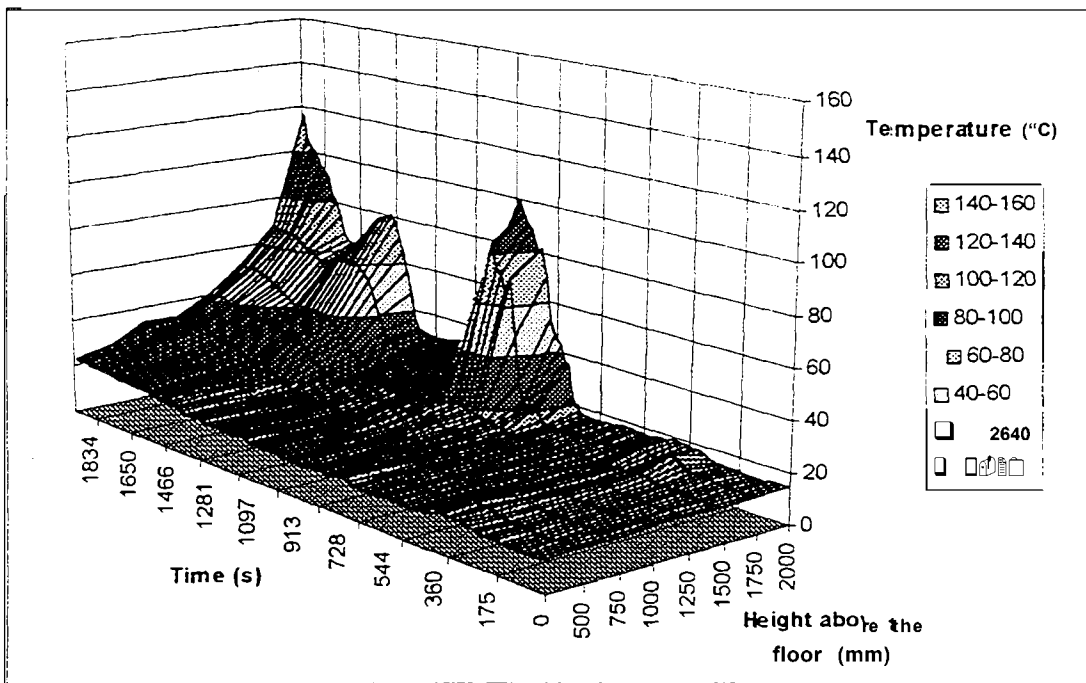

Figure FO3-10: Temperature distribution along the center line of the bum room door

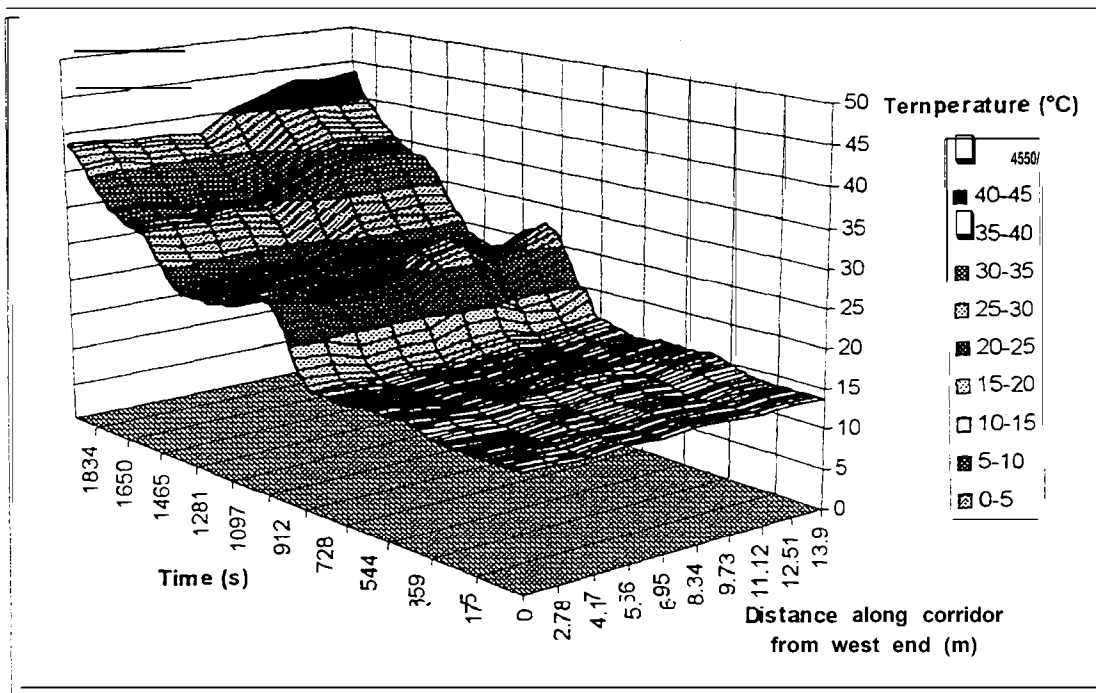

Figure FO3- 11: Temperature along Level 1 corridor (2.0 m above the floor)

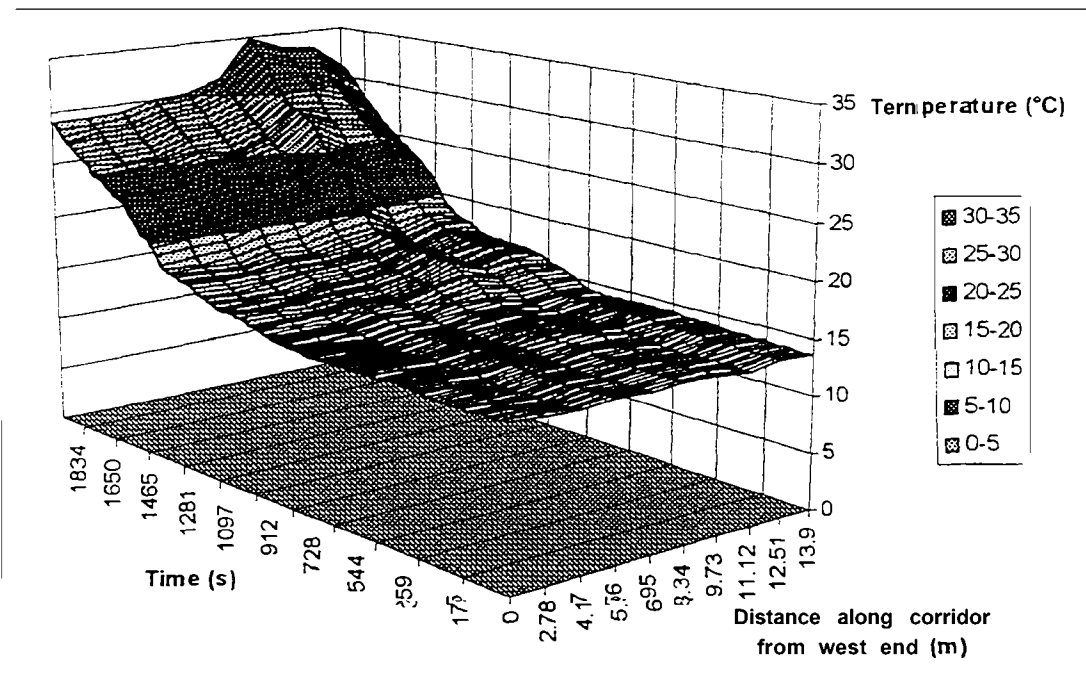

Figure FO3-12: Temperature along Level 1 corridor (1.5 m above the floor)

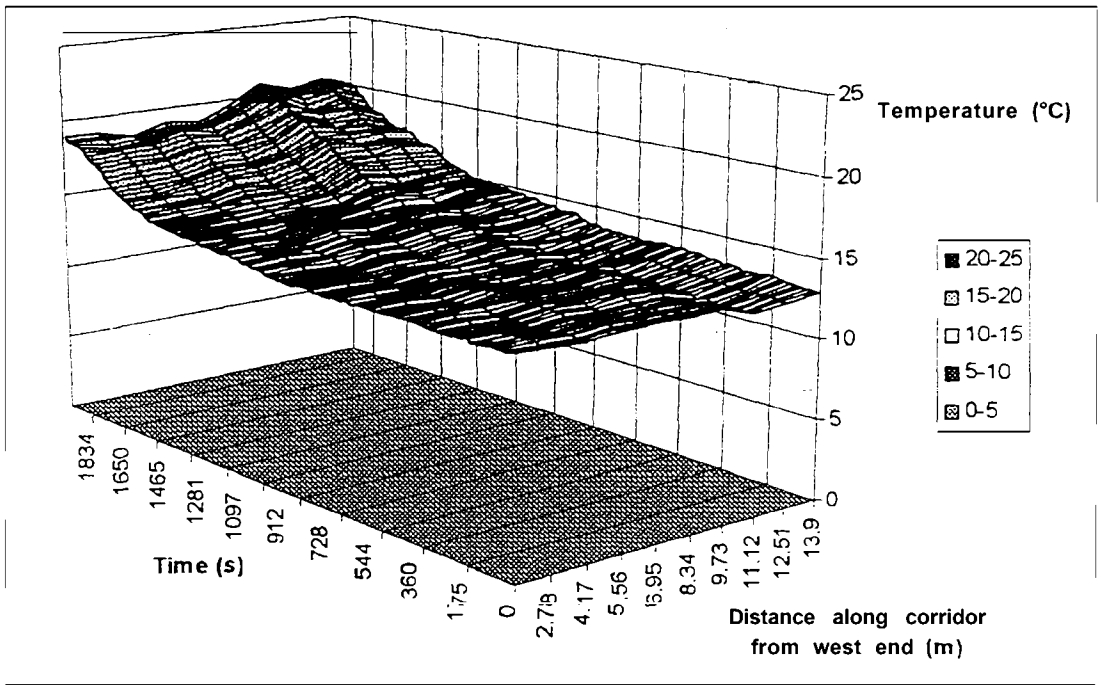

Figure FO3-13 : Temperature along Level 1 corridor (0.5 m above the floor)

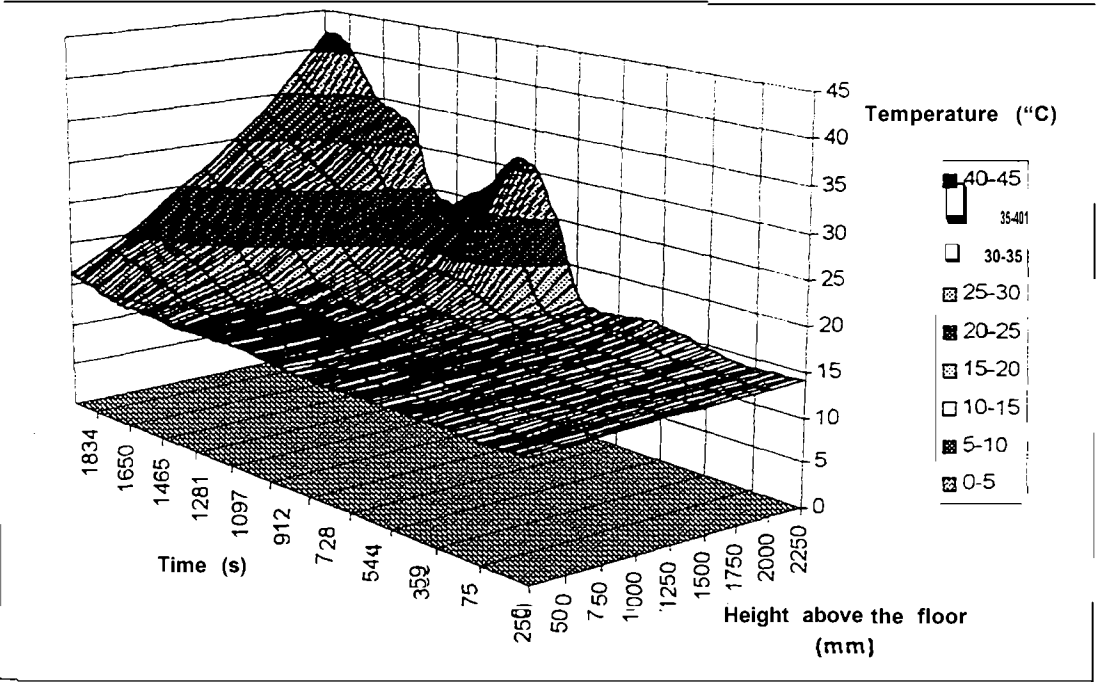

Figure FO3- 14: Vertical temperature distribution in the center of Level 1 corridor

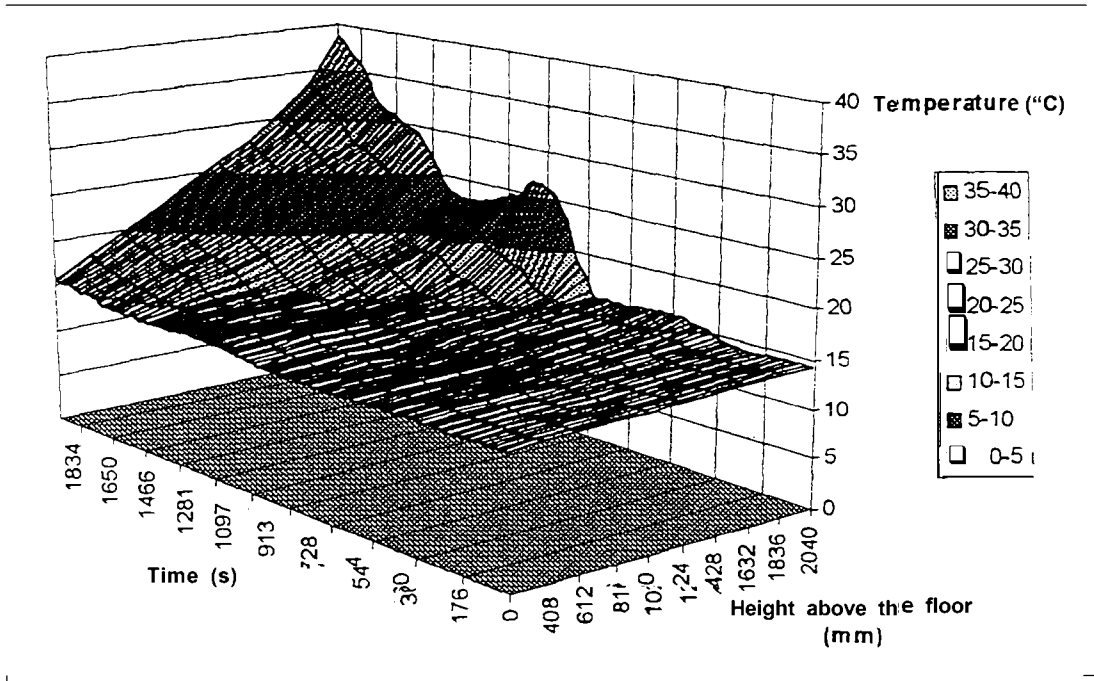

Figure FO3-15: Temperature distribution along the center line of Level 1 stairwell door

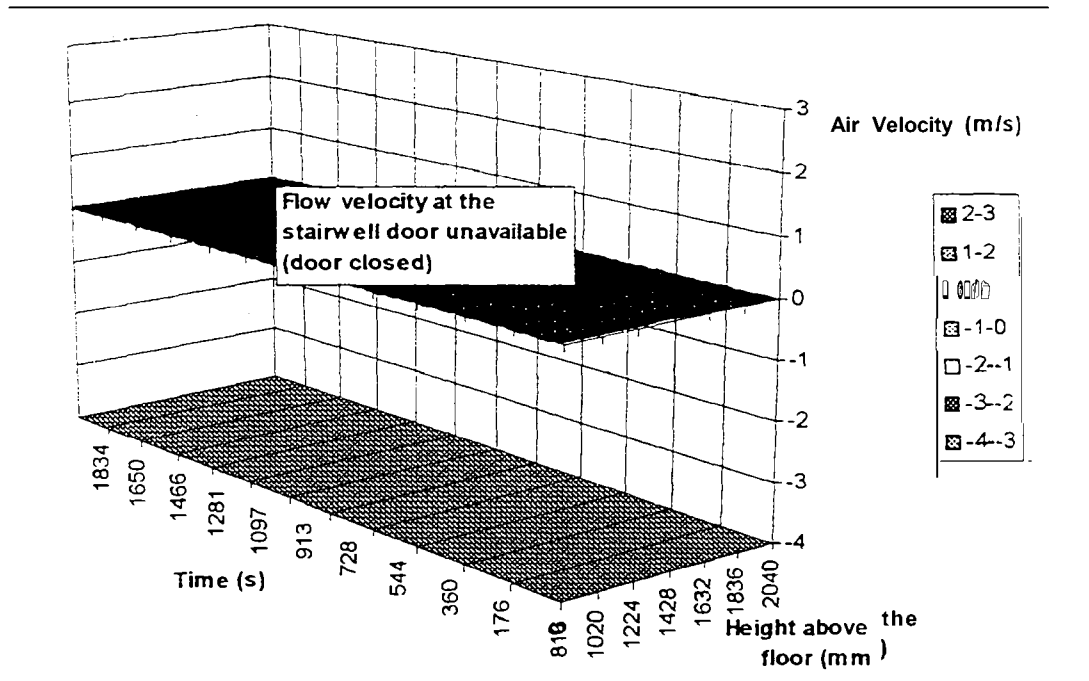

Figure FO3-16: Flow velocity distribution at the center line of Level 1 stairwell door

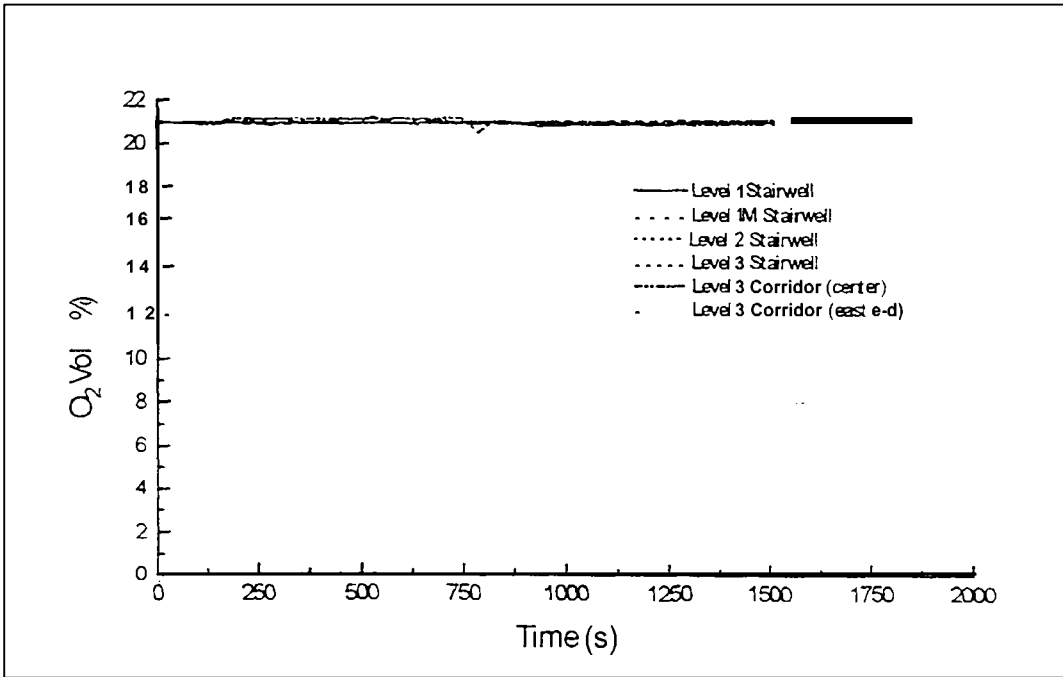

Figure FO3-17: Oxygen concentration at the stairwell doors (1.7 m above the floor)

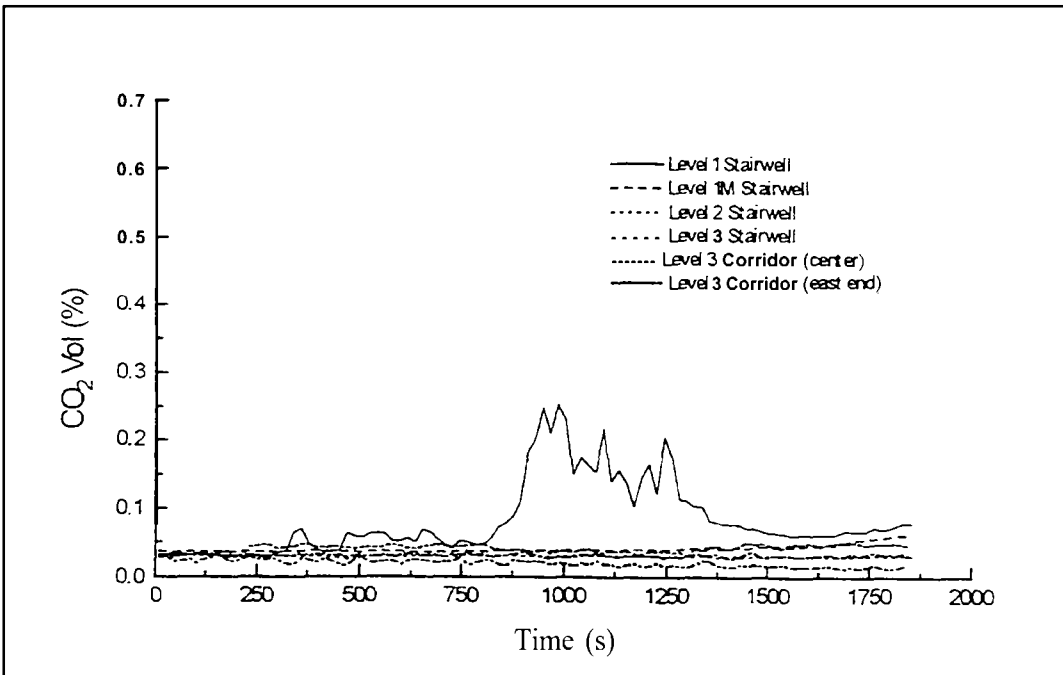

Figure FO3-18: Carbon dioxide concentration at the stairwell doors (1.7 m above the floor)

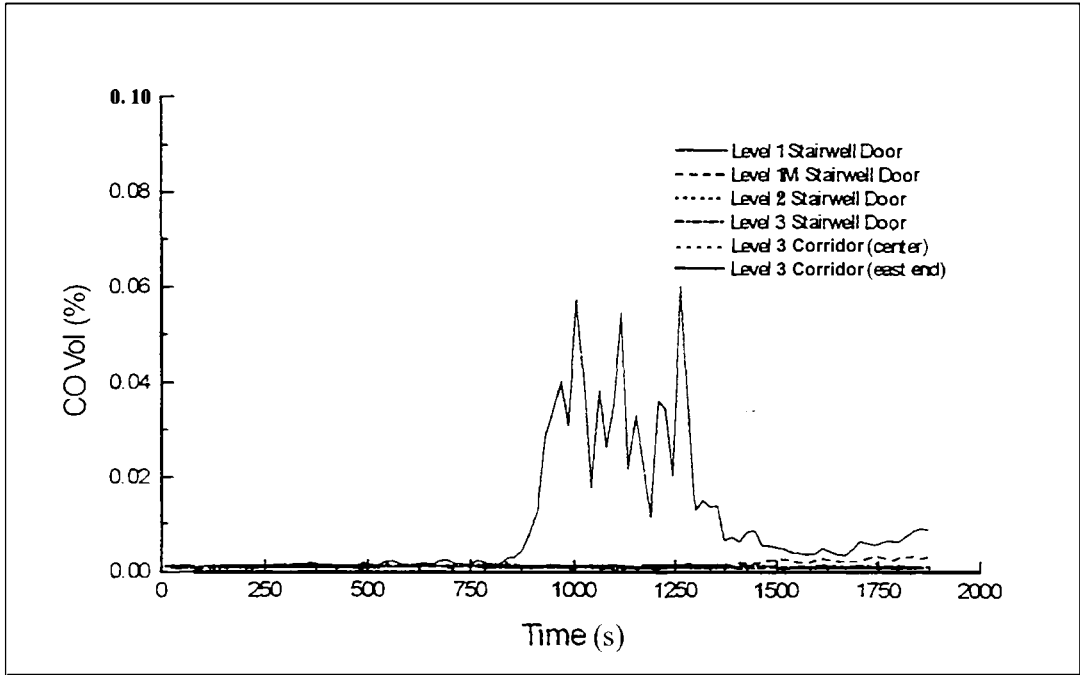

Figure FO3- 19: Carbon monoxide concentration at the stairwell doors (1.7 m above the floor)

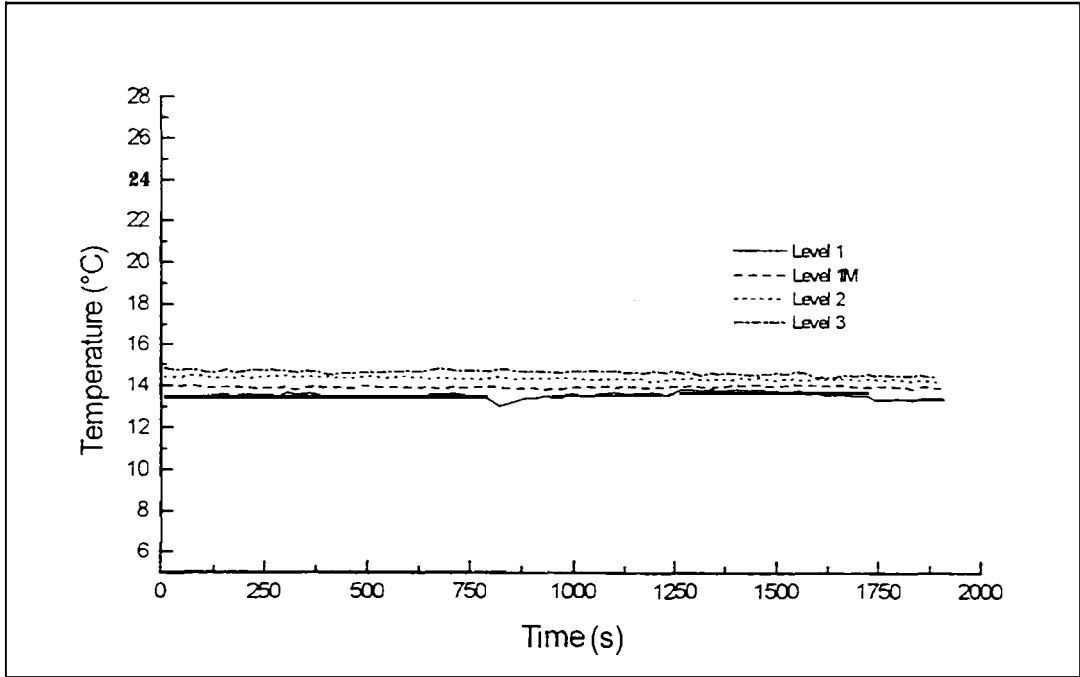

Figure FO3-20: Temperature in the stairwell at each level -North side (1.7 m above the floor)



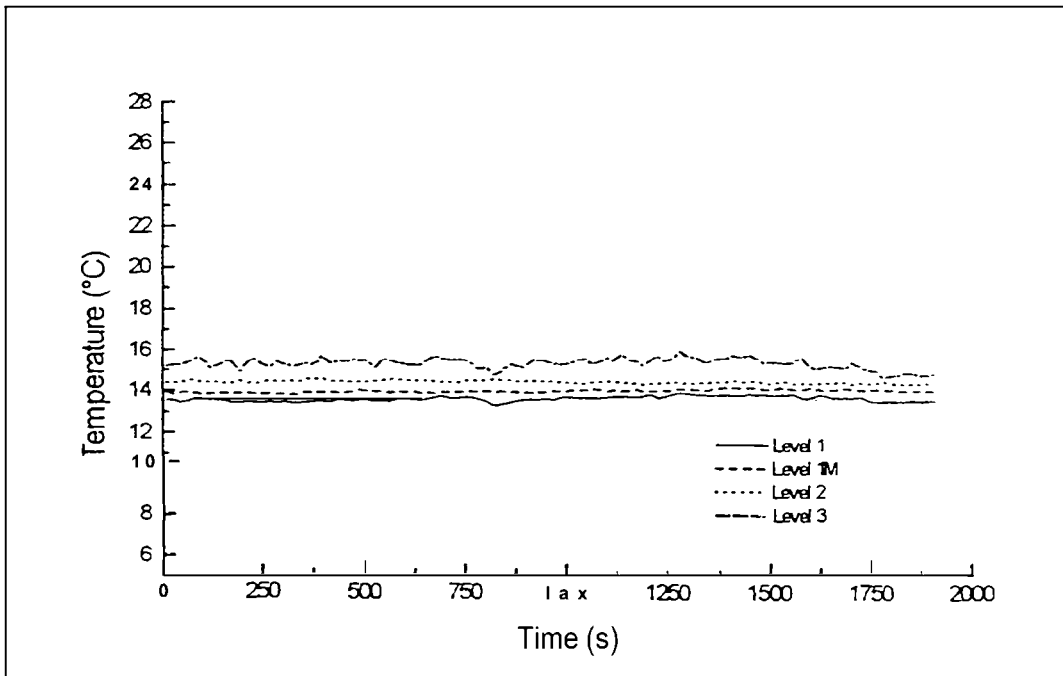

Figure FO3-2 1: Temperature in the stairwell at each level-South side( 1.7 m above the floor)

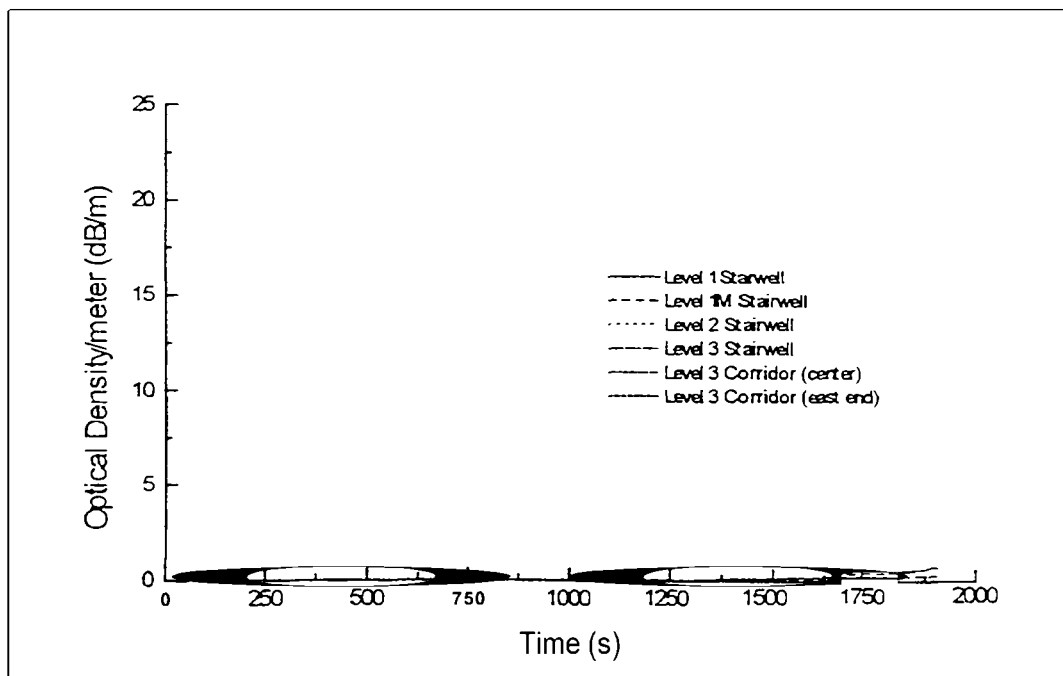

Figure FO3-22: Optical density/m at six locations (1.7 m above the floor)

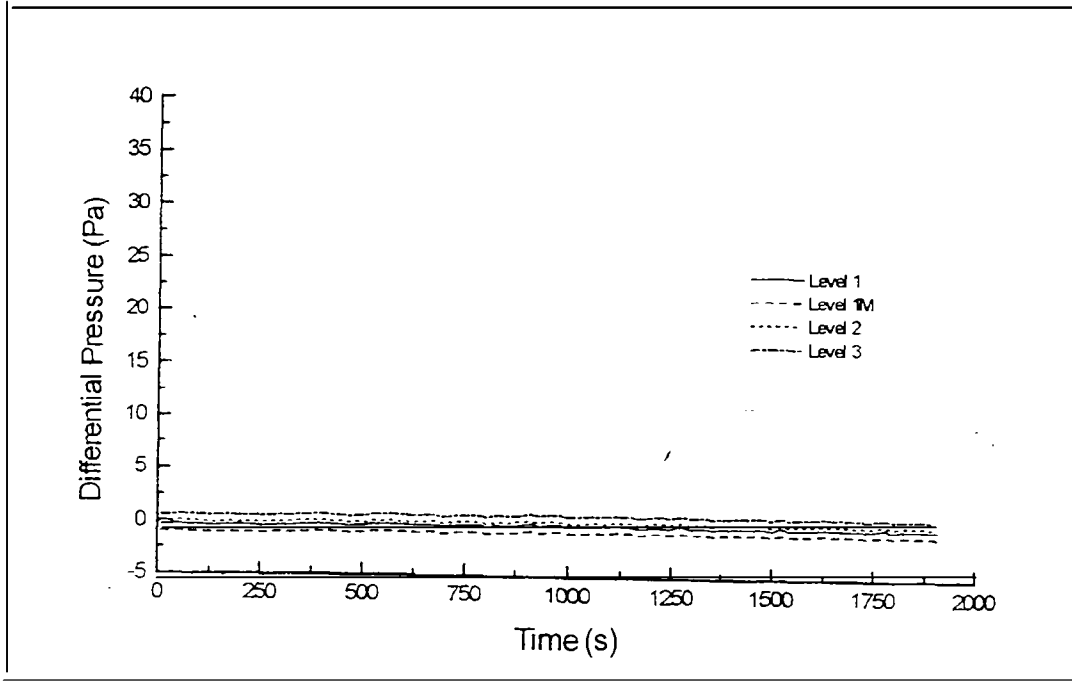

Figure FO3-23: Pressure differences between outside and the stairwell at each level (1.7 m above the floor)

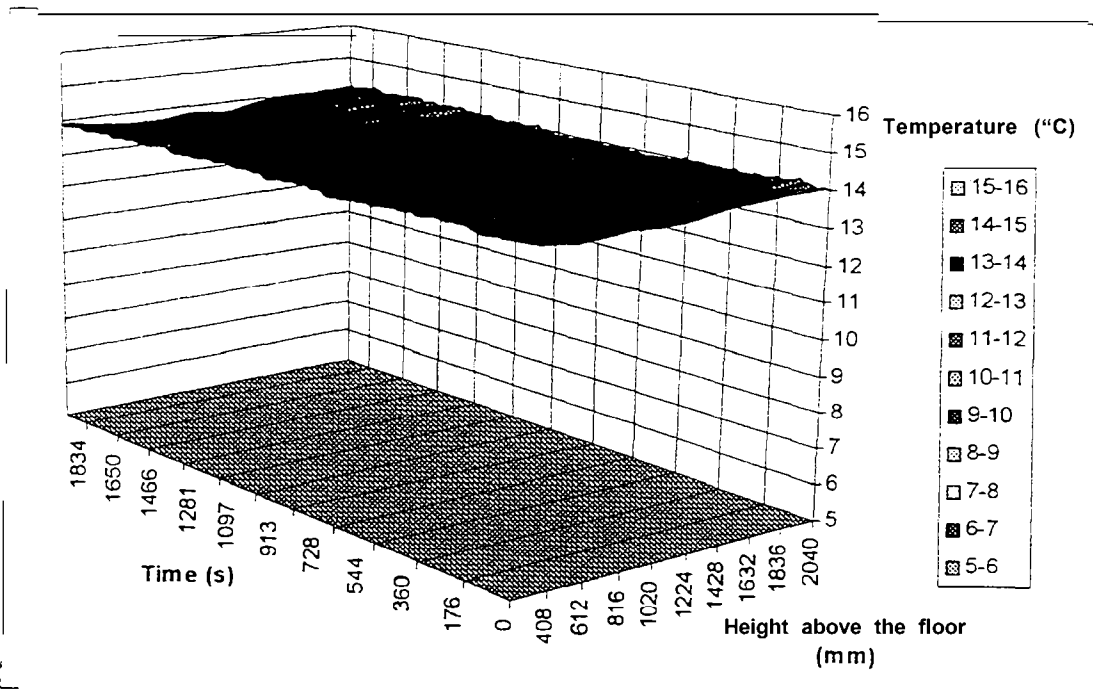

Figure FO3-24: Temperature distribution along the center line of Level 1M stairwell door

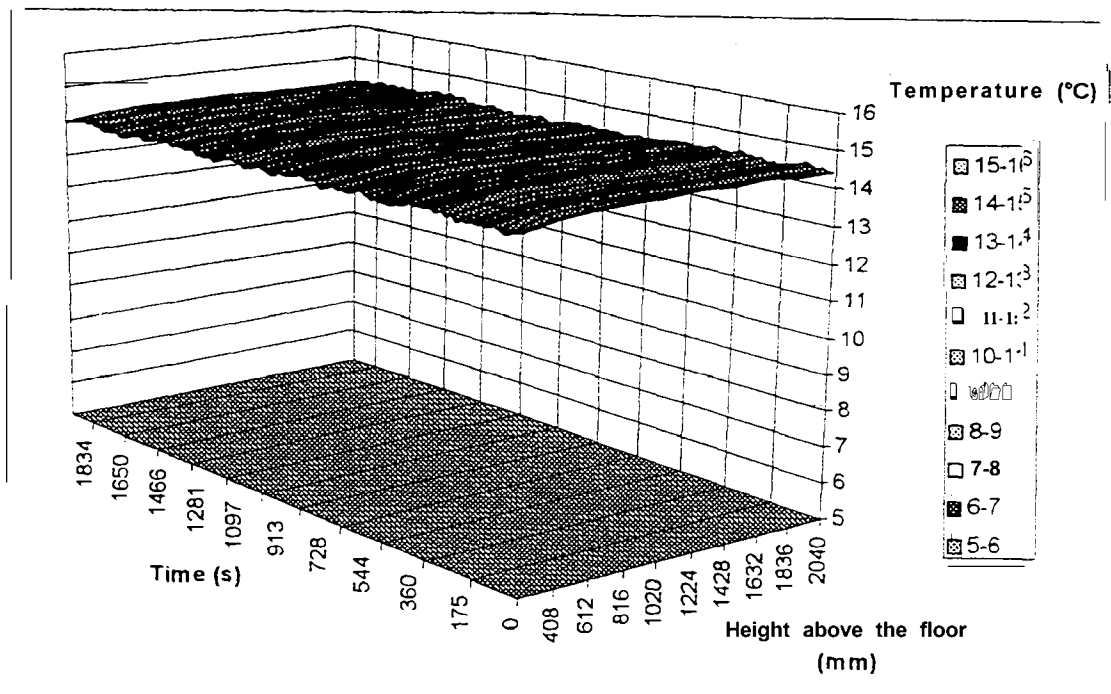

Figure FO3-25: Temperature distribution along the center line of Level 2 stairwell door

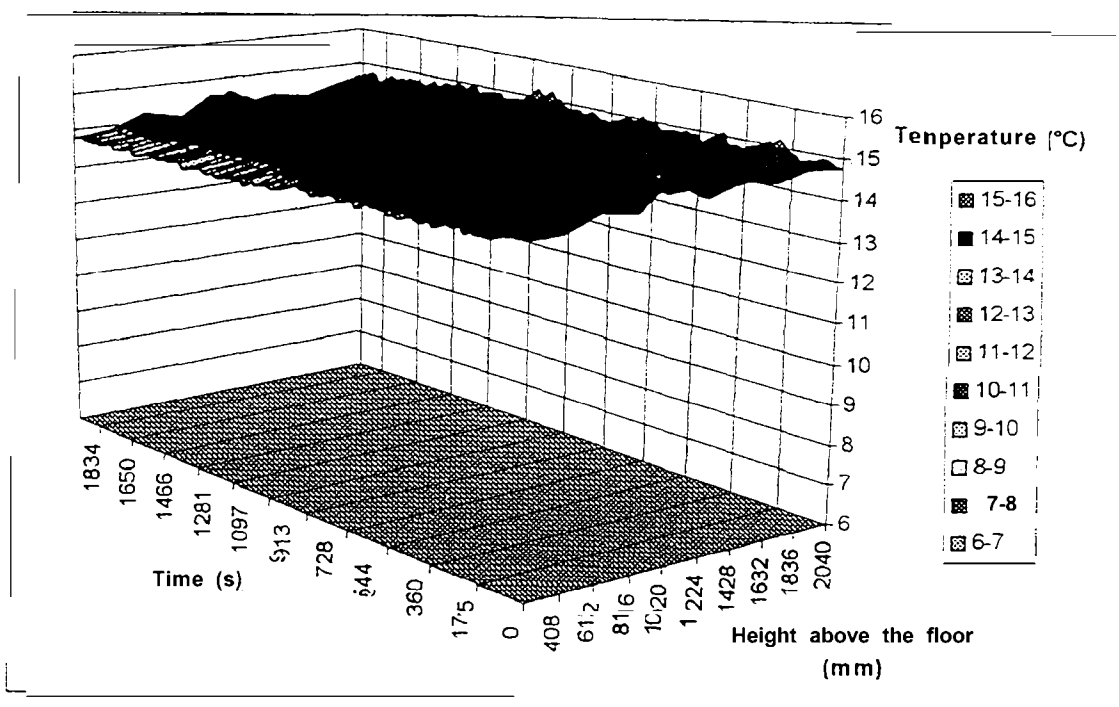

Figure FO3-26: Temperature distribution along the center line of Level 3 stairwell door

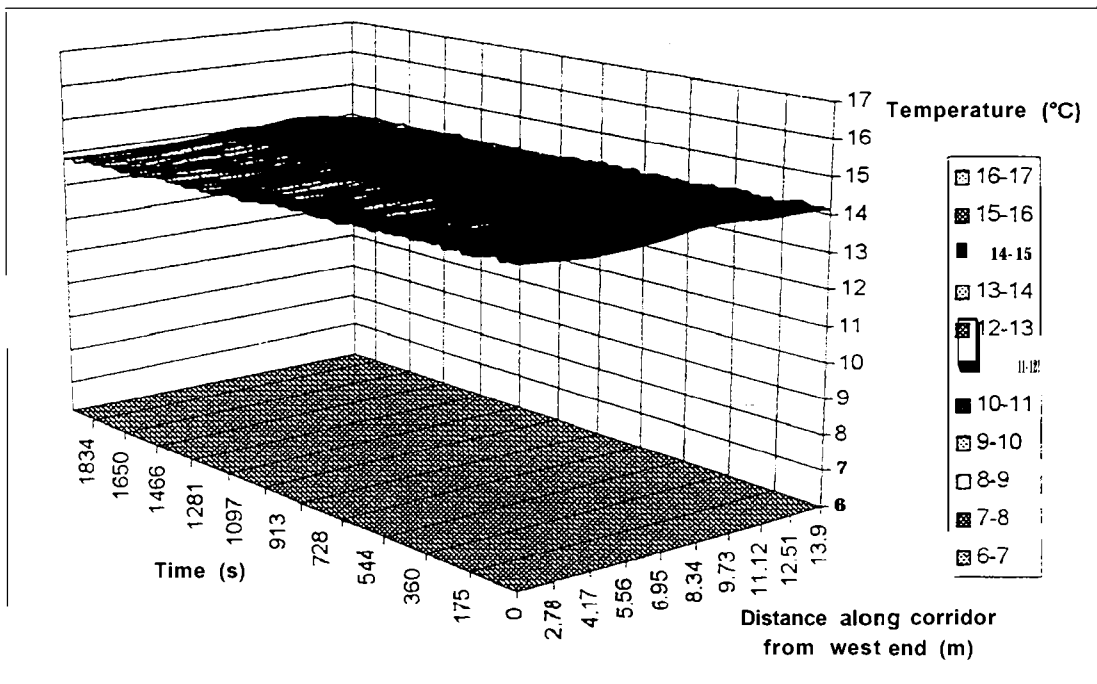

Figure FO3-27: Temperature distribution along Level 1M corridor (1.7 m above the floor)

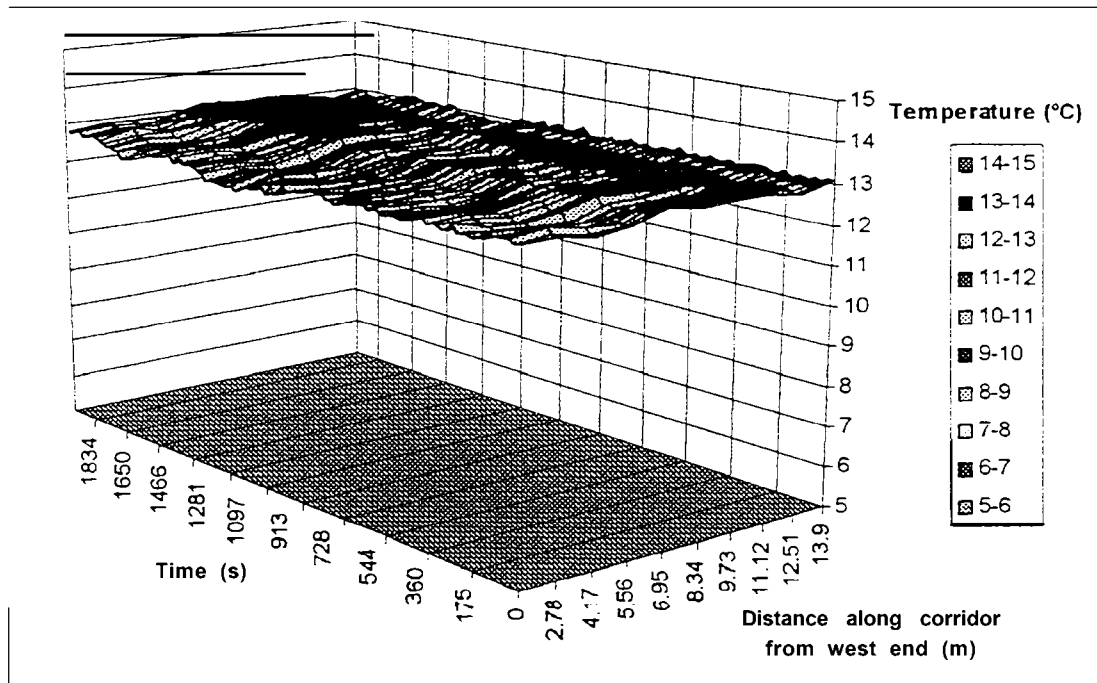

Figure FO3-28: Temperature distribution along Level 2 corridor (1.7 m above the floor)

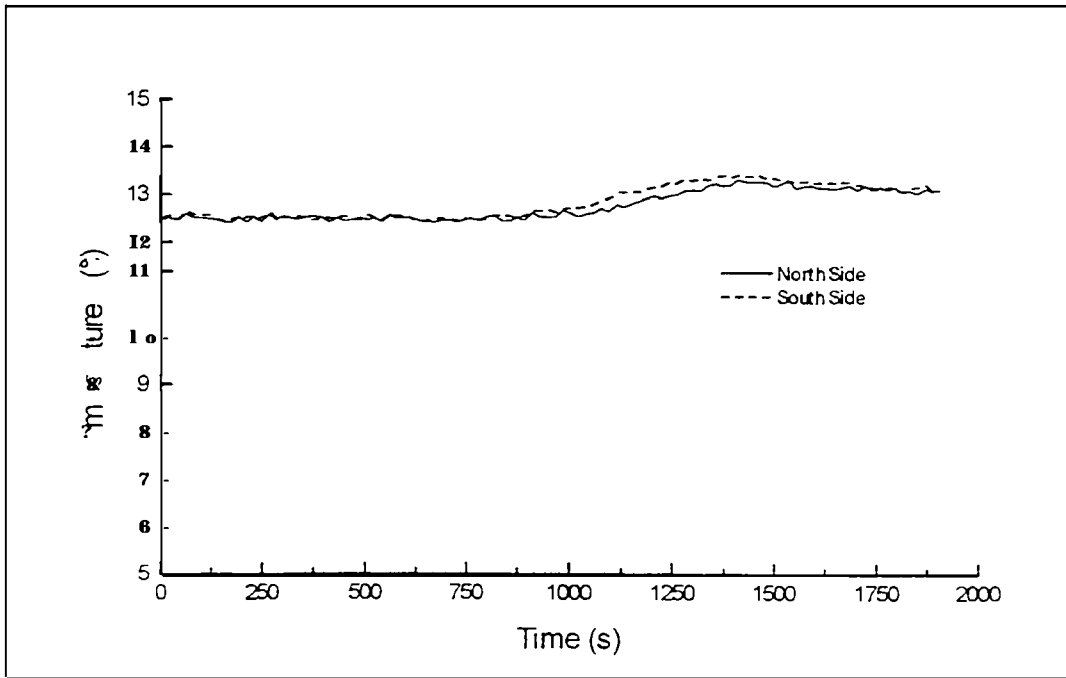

Figure FO3-29: Temperatures in Room 20 1 (1.7 m high)

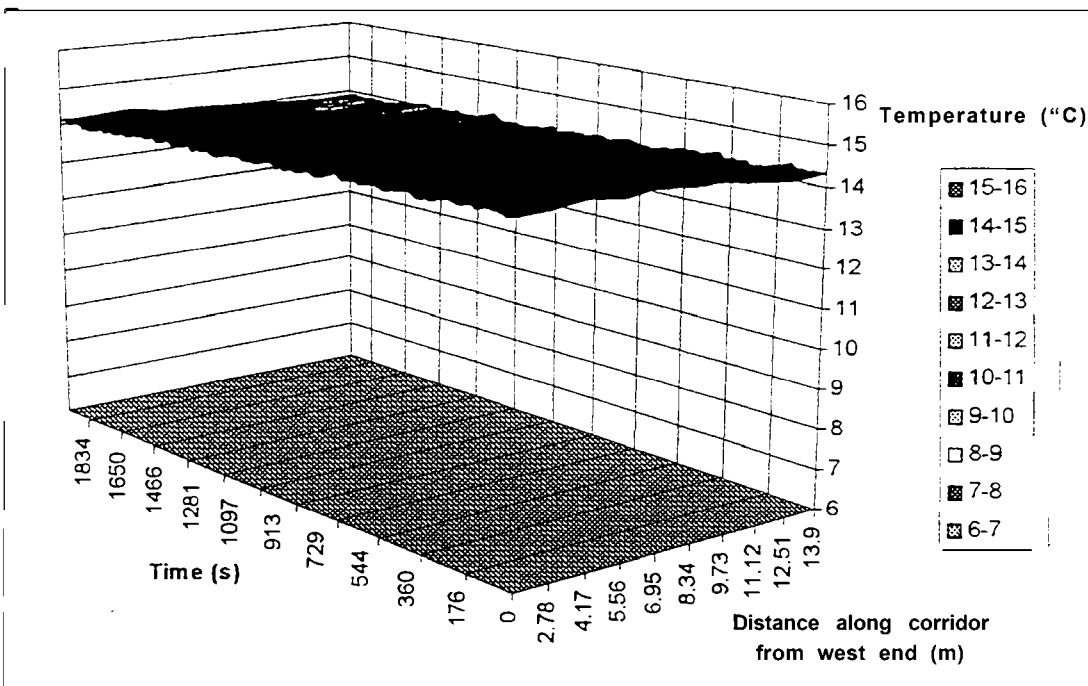

Figure FO3-30: Temperature distribution along Level 3 corridor (1.7 m above the floor)

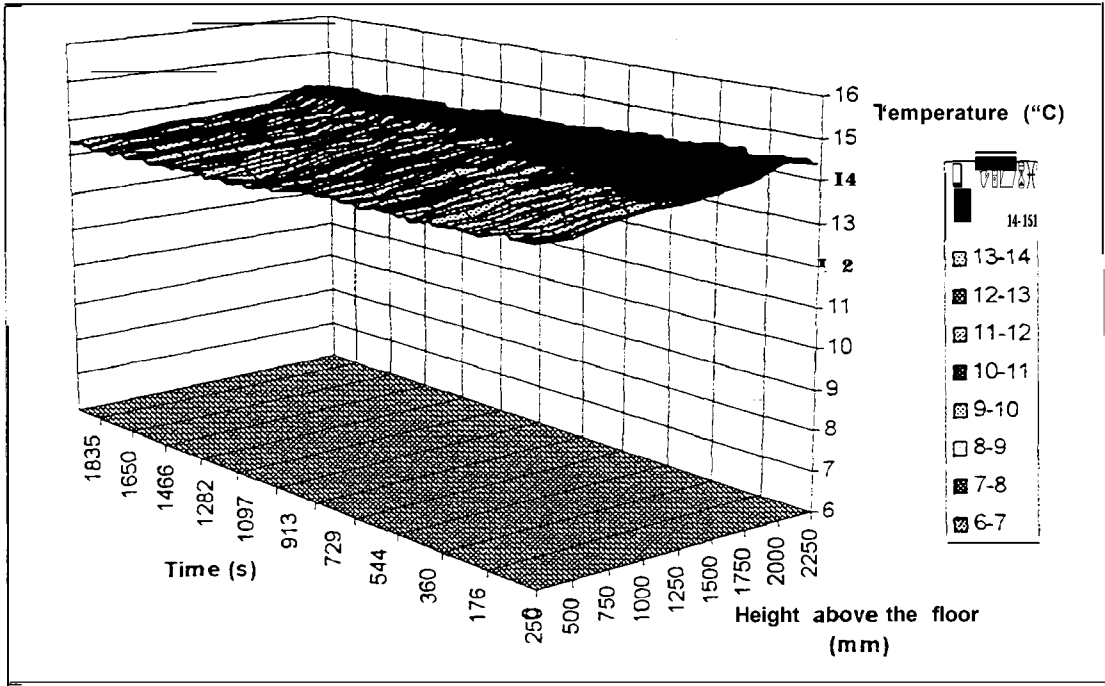

Figure FO3-31: Vertical temperature distribution in the center of Level 3 corridor

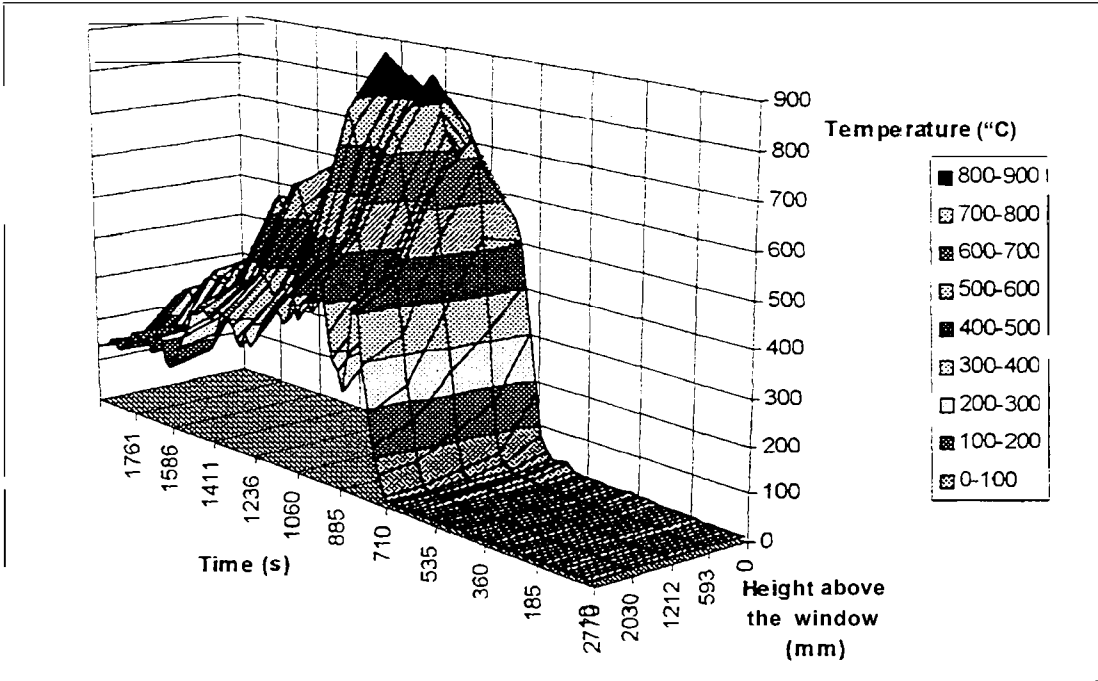

Figure FO3-32: External temperature along the center line of the bum room window (0.02 m from the wall)

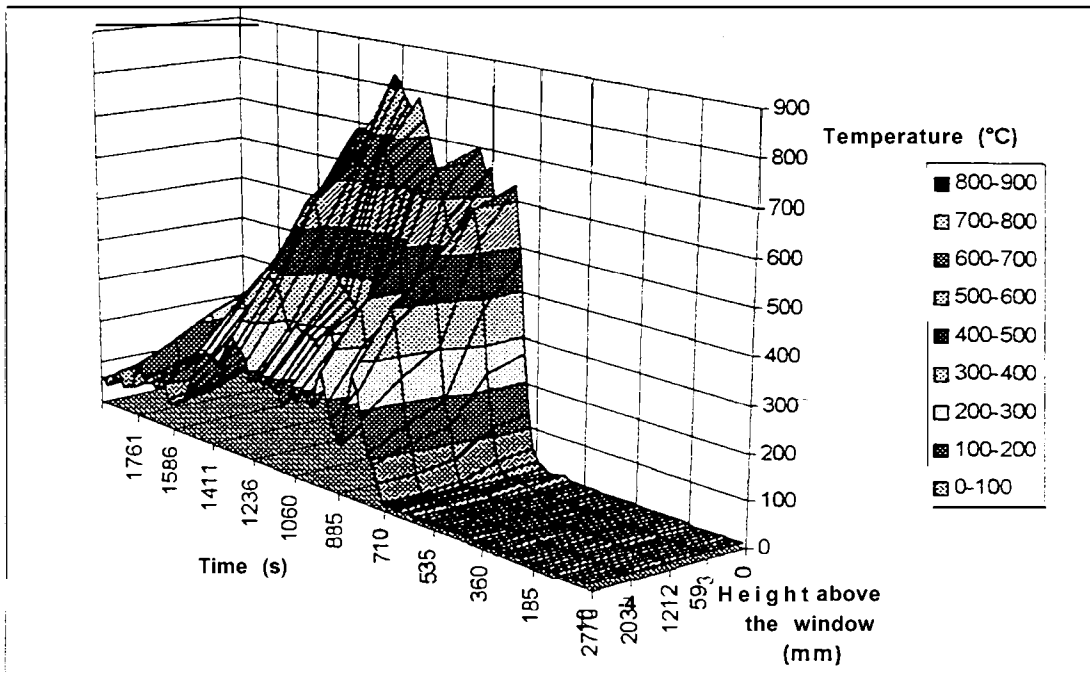

Figure FO3-33 : External temperature along the center line of the bum room window (0.5 m from the wall)

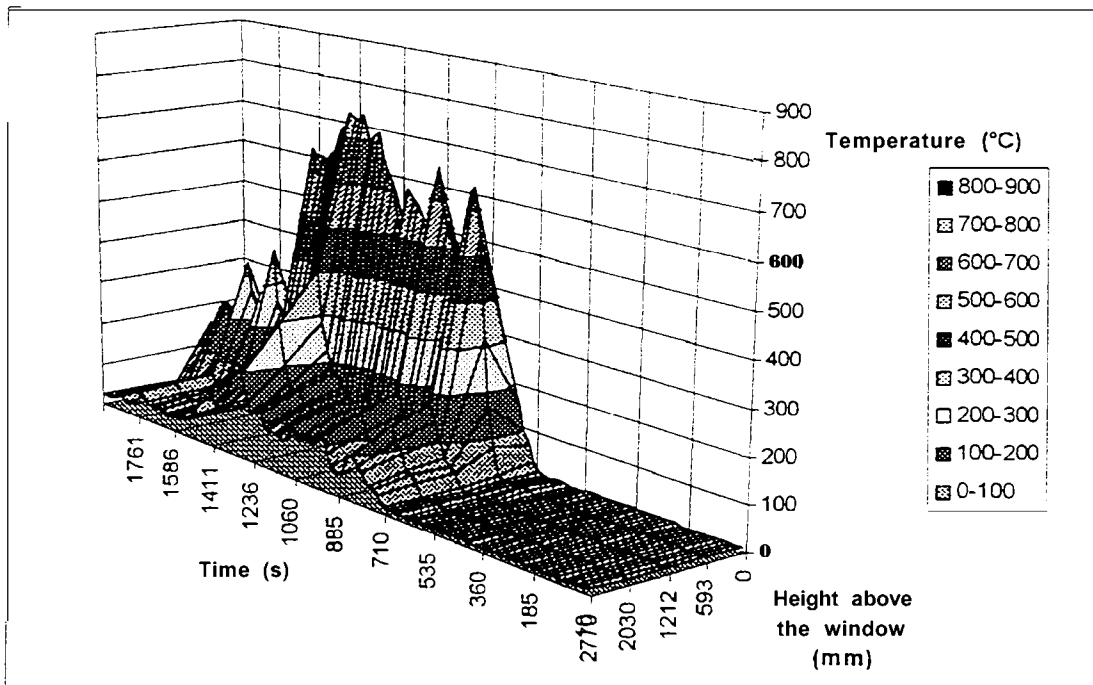

Figure FO3-34: External temperature along the center line of the bum room window (1.0 m from the wall)

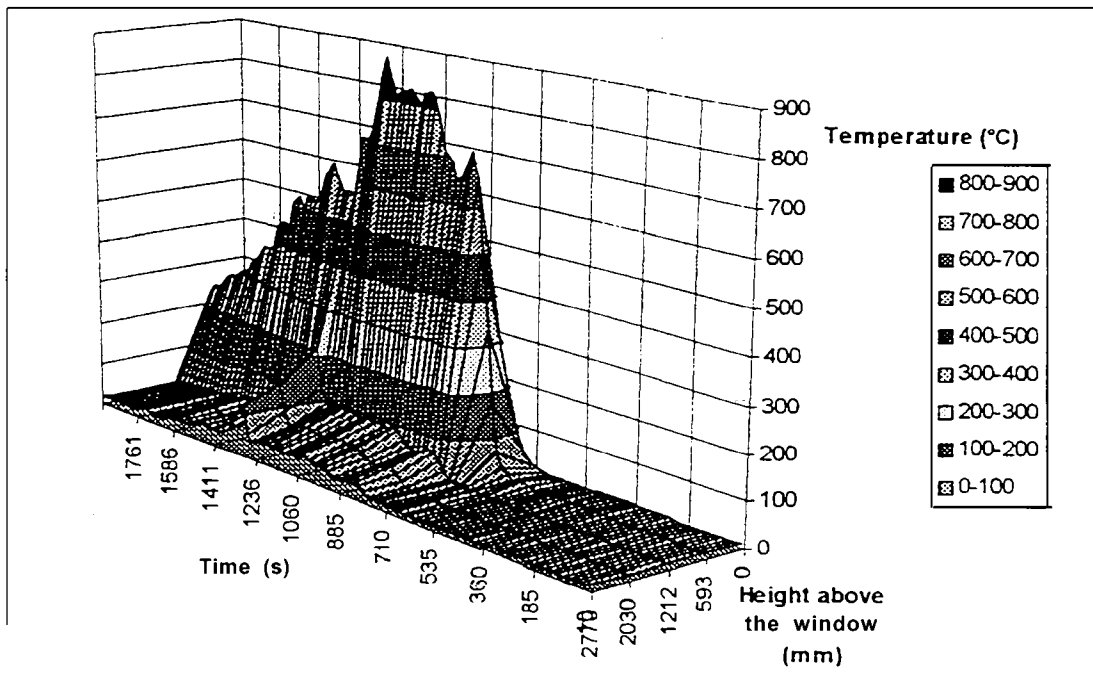

Figure FO3-35: External temperature along the center line of the bum room window (1.5 m from the wall)

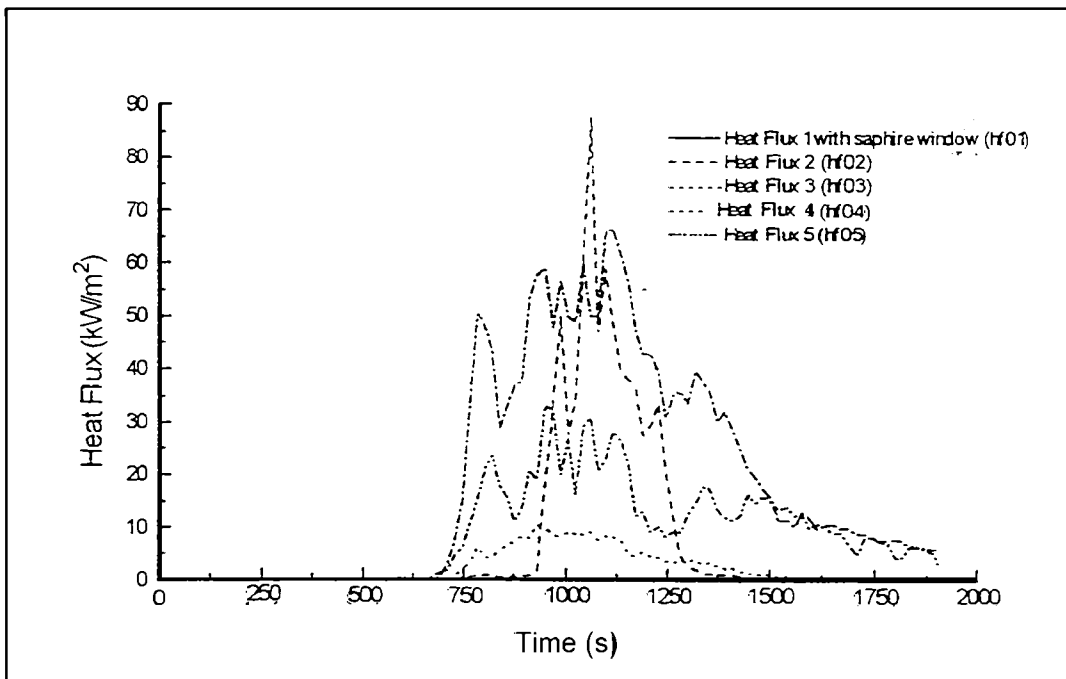

Figure FO3-36: External heat flux measurements (Refer to Figure 25 for locations)



## 12. Flashover Test FO4

**Test Conditions:**     **Bum Room Door Open**  
                               **Level 1 Stairwell Door Open**

### Observations:

- 0:00 Ignition
- 0:55 Photo-optical detector activated
- 2:50 Smoke layer reaching to the top of the window (0.4 m from the ceiling)
- 3:00 Sprinkler above the small platform activated (detection only)
- 3:35 Smoke layer filling half of the room (1.2 m from the ceiling)
- 5:10 Smoke to the top of the couch (1.45 m from the ceiling)
- 5:15 Initial crack in middle pane
- 5:25 Sprinkler above the large platform activated (detection only)
- 5:47 More cracking of bum room window  
*(glass thermocouples fell off before criteria was reached, so fire was allowed to progress without intervention)*
- 5:55 Sprinkler in Level 1 corridor activated (detection only)
- 6:10 Smoke layer to floor level
- 6:35 Dislodgment of middle pane
- 7:35 More dislodgment of glass in bum room window (middle and left panes)
- 7:55 Remaining glass in middle pane dislodged
- 9:00 Flashover occurs
- 10:15 Right pane dislodgment  
           Flames 1.2 m high above the window opening
- 11:05 Some dislodgment of 1M window
- 12:40 More dislodgment of 1M window  
           Flames 2.0 m high above the window opening
- 18: 50 Bum room door clearly visible through window opening
- 20:30 Very little flaming coming out of bum room window; mainly hot gases

Although the window was not lowered in this test most of the window dislodged in approximately 2 minutes. This was the first test that smoke was seen to be coming out of gaps in the stairwell shaft as it was also the first test the with Level I stairwell door open. The P/U in Level 1 corridor was unaffected by the fire. The carpet was also undamaged except for a few char marks on the pieces close to the bum room door.

**Table 10: Summary of results for Test F04**

<b>In the Bum Room</b>	
Maximum Heat Release Rate	9.47 MW
Maximum Peak Temperature	1110 °C
Maximum Average Room Temperature	896 °C
Minimum Oxygen Concentration	0.68 Vol %
Maximum Total Heat Flux	122 kW/m <sup>2</sup>

Time untenability reached (1 00°C)	323 s
<b>At the Bum Room Door</b>	
Maximum CO Concentration a	6.2 Vol %
Maximum CO <sub>2</sub> Concentration	13 Vol %
Maximum Temperature	907 °C
Minimum Oxygen Concentration	0.6 Vol %
<b>In Level 1 Corridor</b>	
Maximum Temperature 1.5 m above the floor	517 °C
Maximum Temperature in the center of the Corridor	550°C
<b>Stairwell</b>	
Maximum Temperature Level 1	151 °C
Level 1M	105 °C
Level 2	58 °C
Level 3	48 °C
<b>Level 3 Corridor</b>	
Maximum Temperature	58 °C
<b>External</b>	
Maximum External Temperature	830 °C
Maximum Total Heat Flux	80 kW/m <sup>2</sup>

Note: A full list of detector and sprinkler activation times is shown in Table 15 & 16. Only the time for the first detector activated is listed in the above observations.

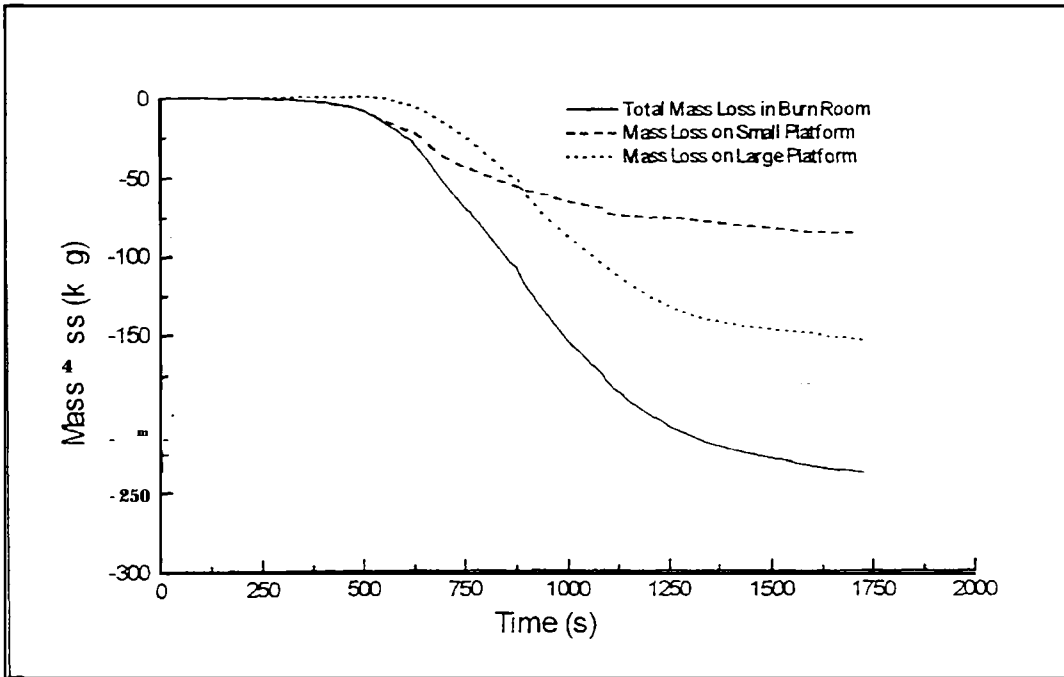

Figure FO4-1: Combined mass loss in the burn room

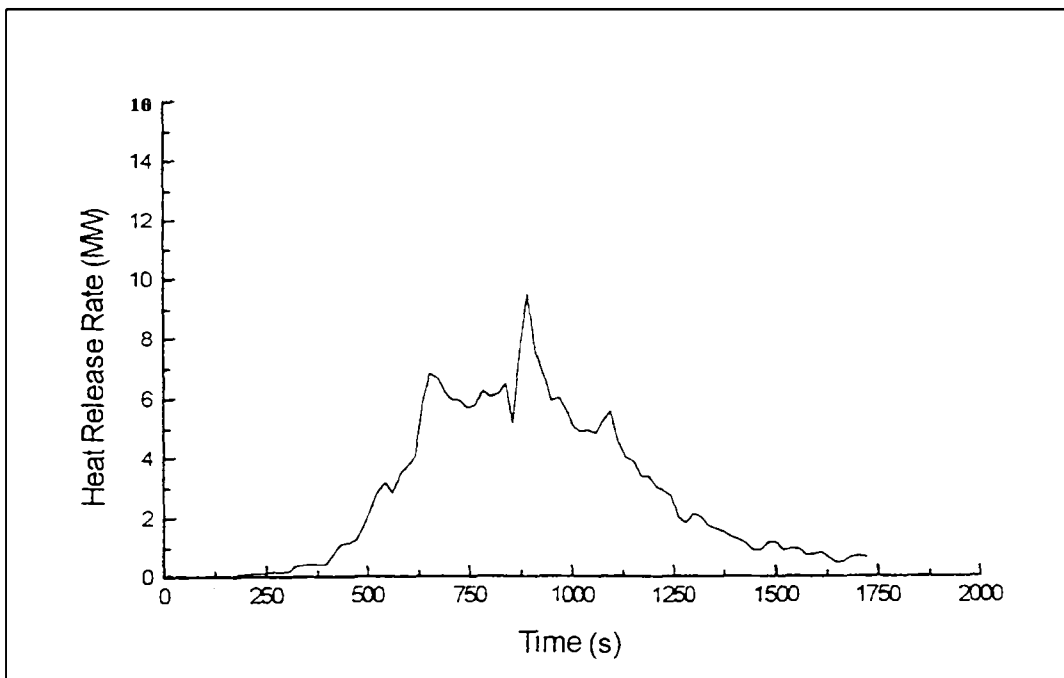

Figure FO4-2: Total heat release rate in the burn room

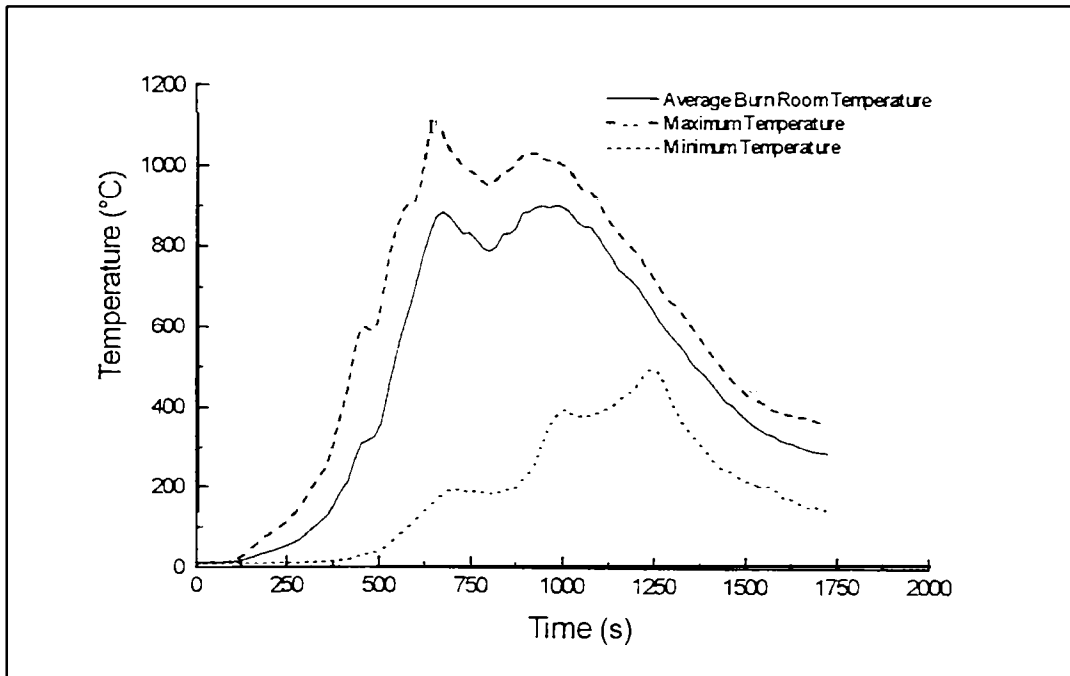

Figure FO4-3: Average, maximum and minimum temperatures in the burn room

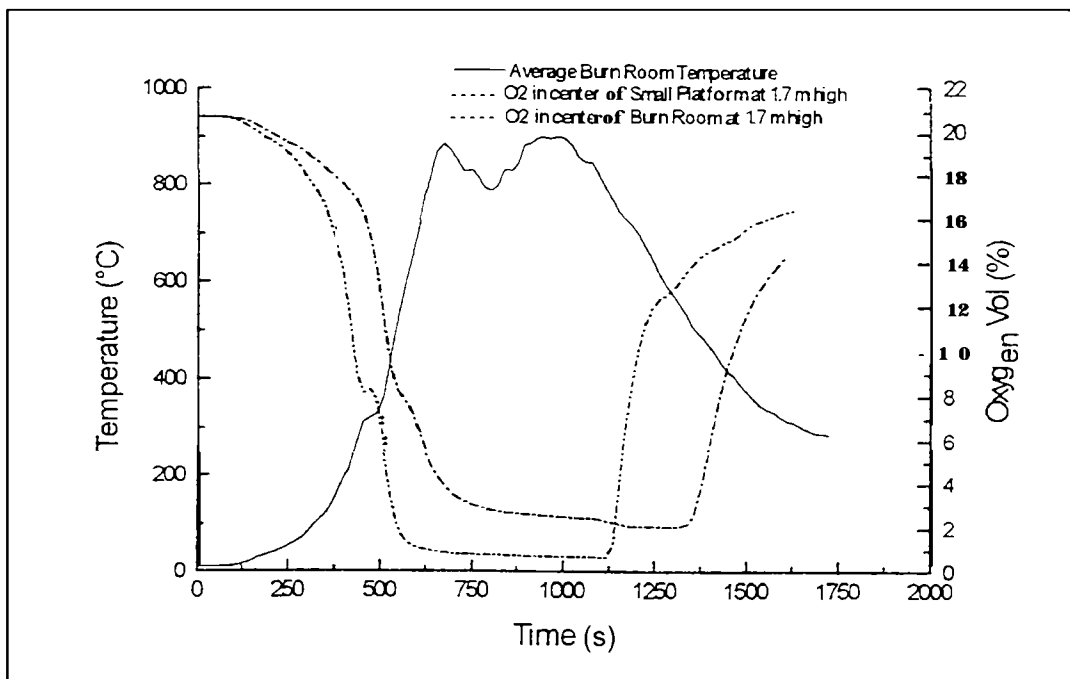

Figure F04-4: Oxygen concentration and average temperature in the bum room

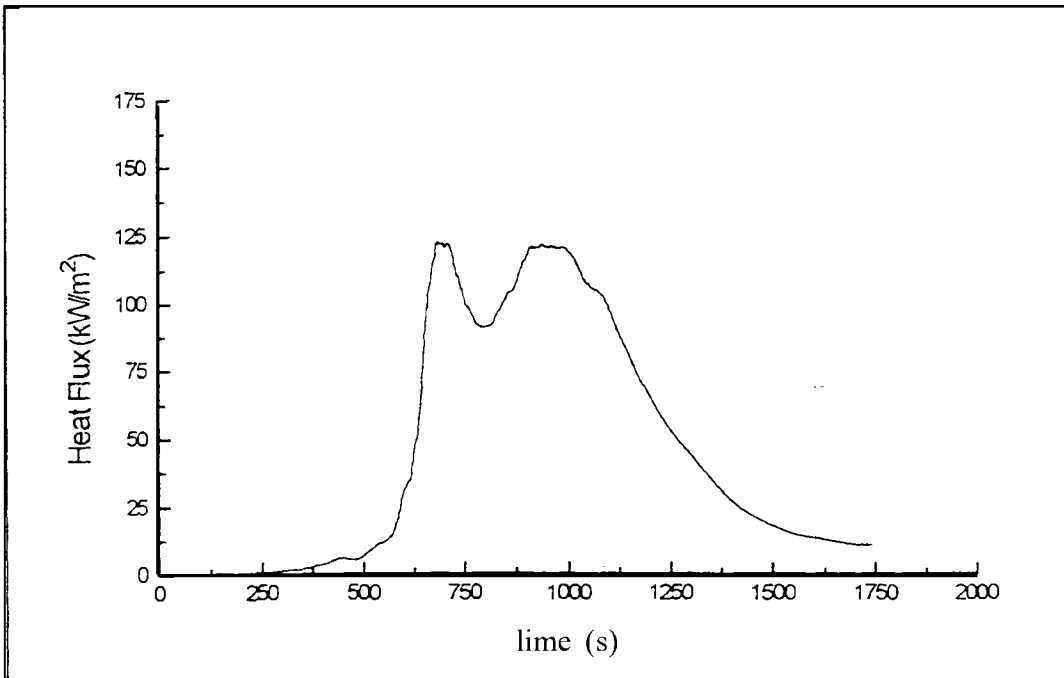

Figure FO4-5: Total heat flux in the center of the bum room

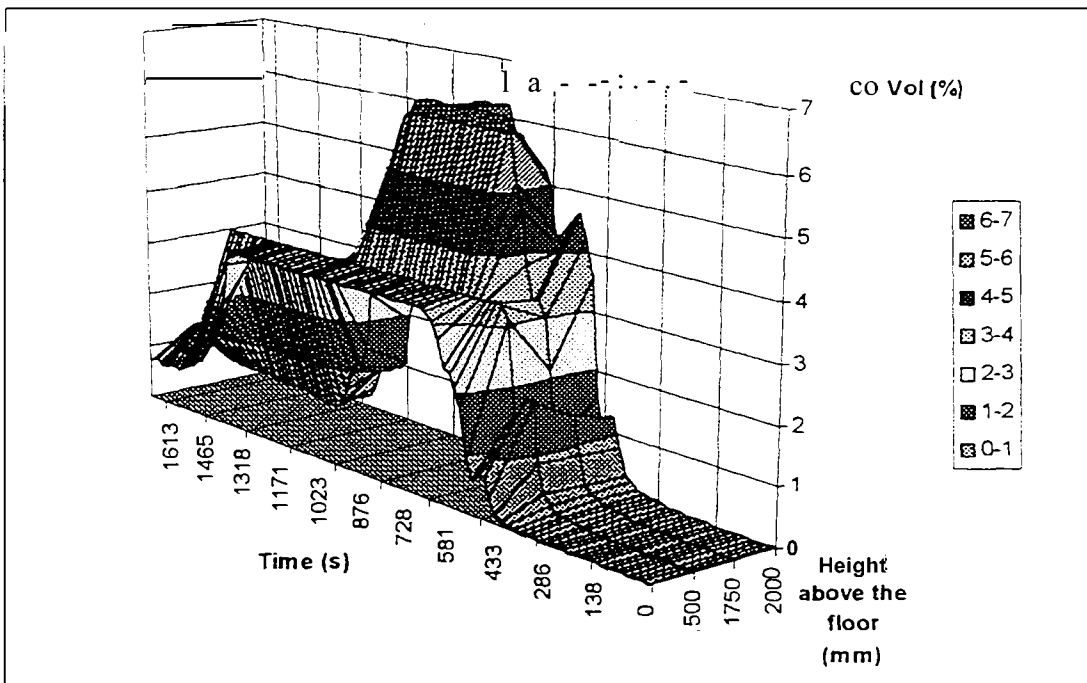

Figure FO4-6: Carbon monoxide concentration along the center line of the bum room door

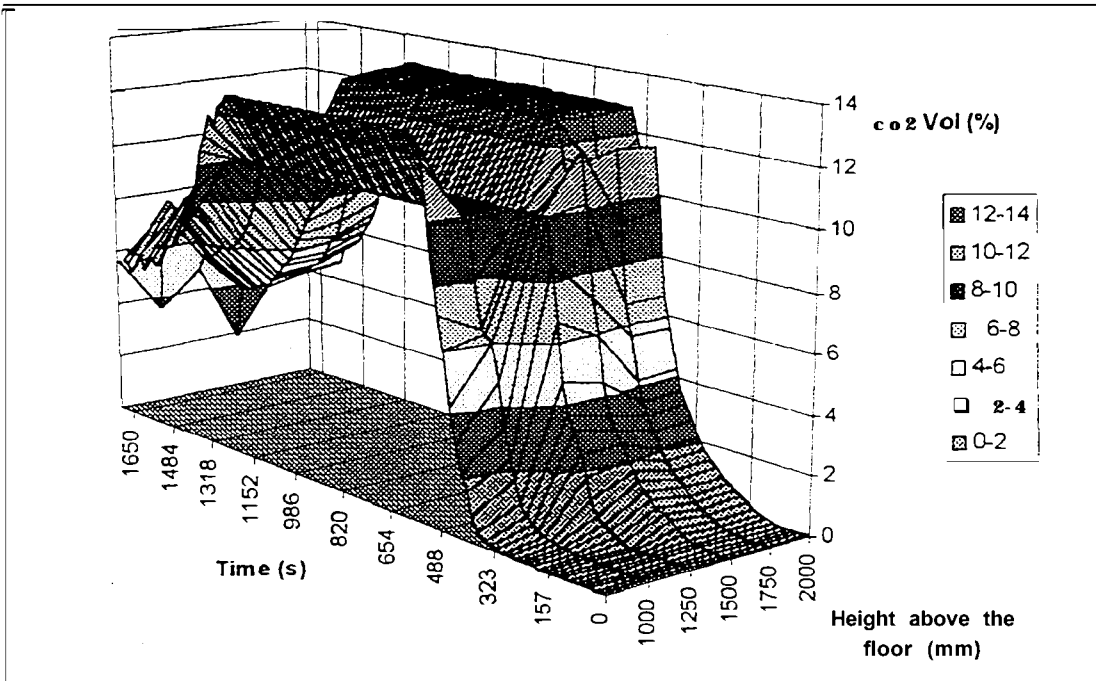

Figure FO4-7: Carbon dioxide concentrations along the center line of the bum room door

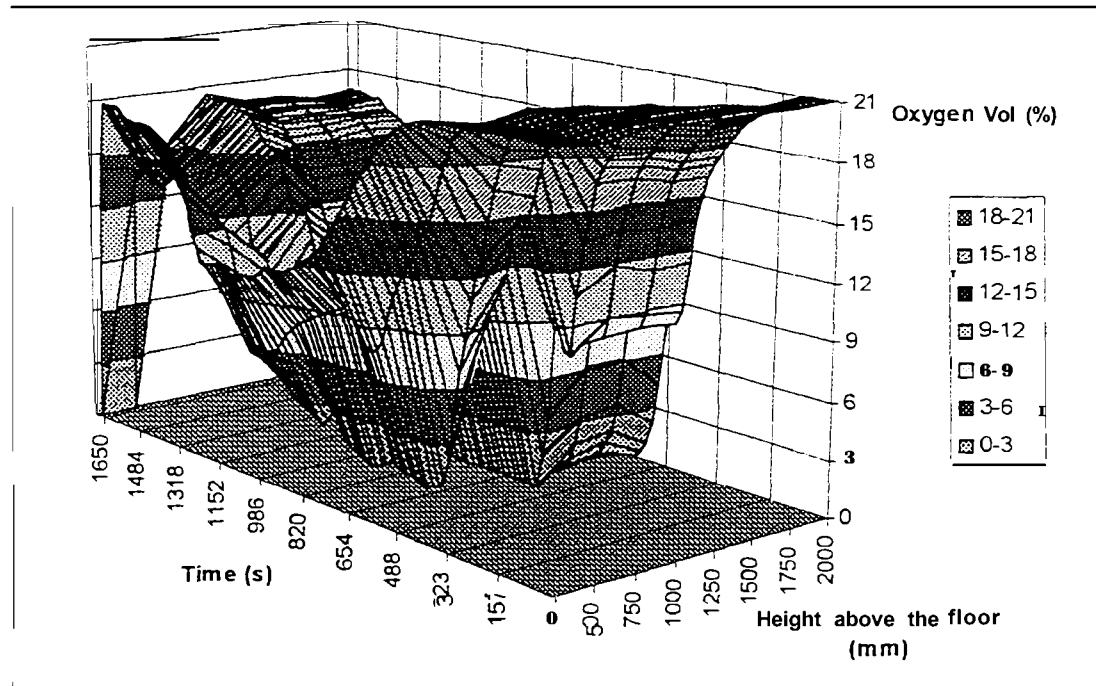

Figure FO4-8: Oxygen concentrations along the center line of the bum room door

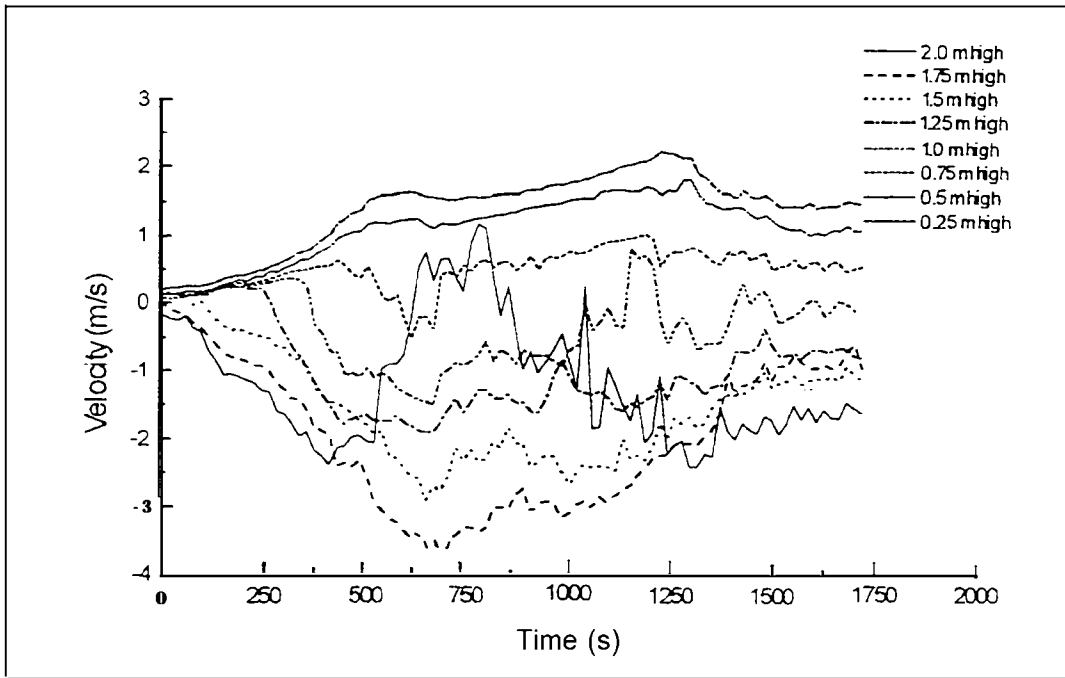

Figure FO4-9: Flow velocity distribution at the center line of the bum room door

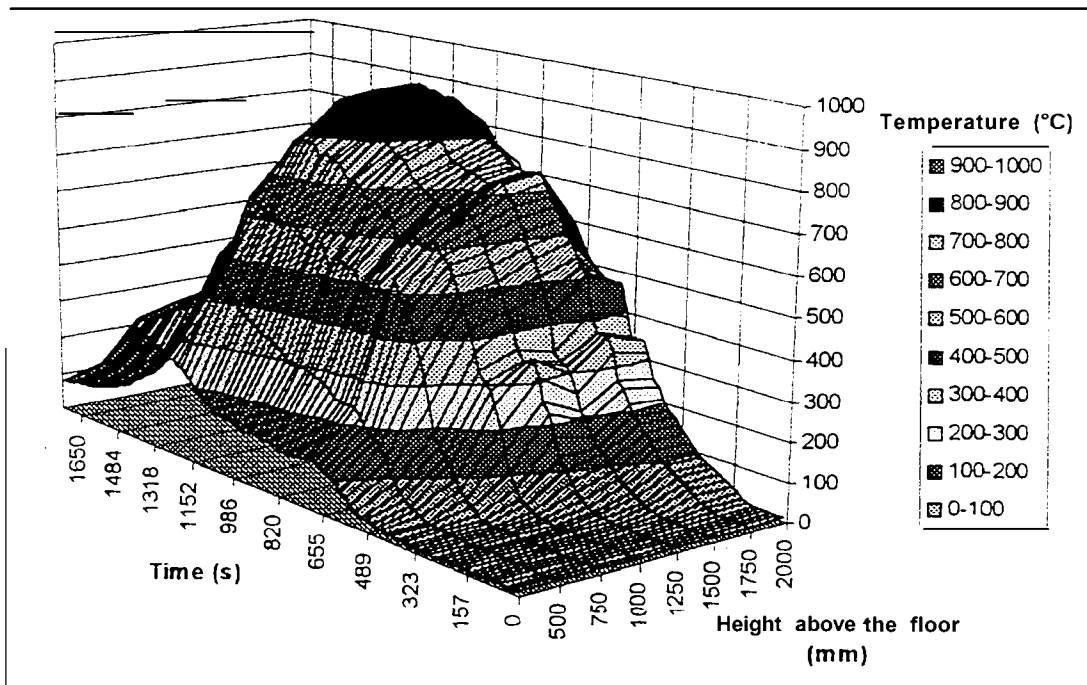

Figure FO4-10: Temperature distribution along the center line of the bum room door

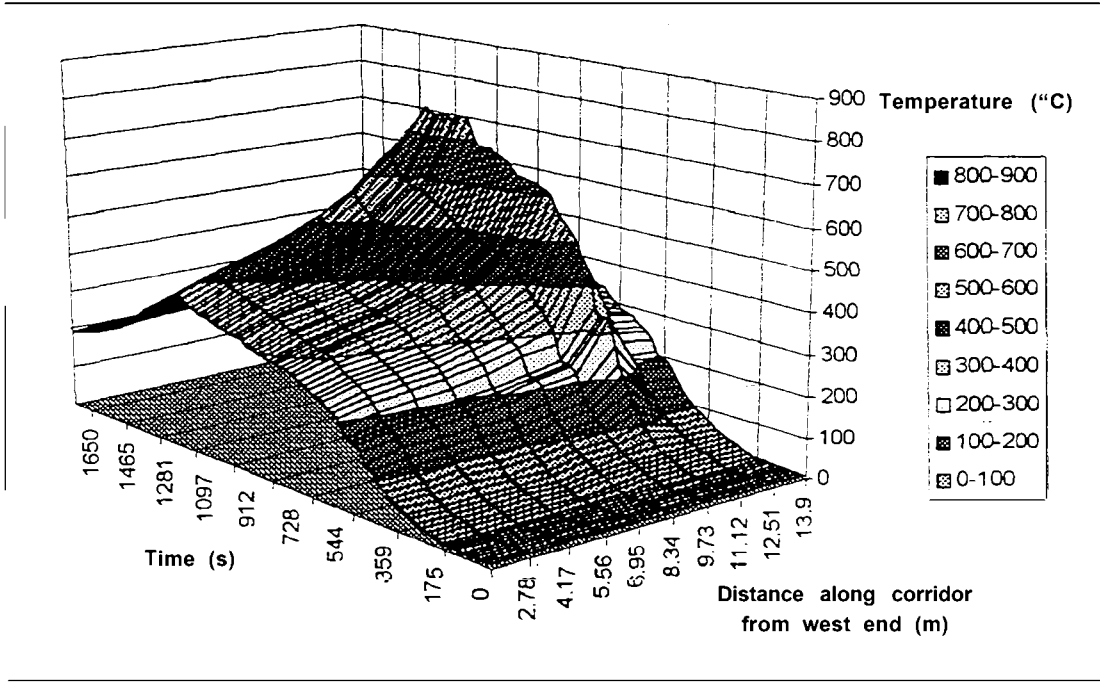

Figure FO4-11: Temperature along Level 1 corridor (2.0 m above the floor)

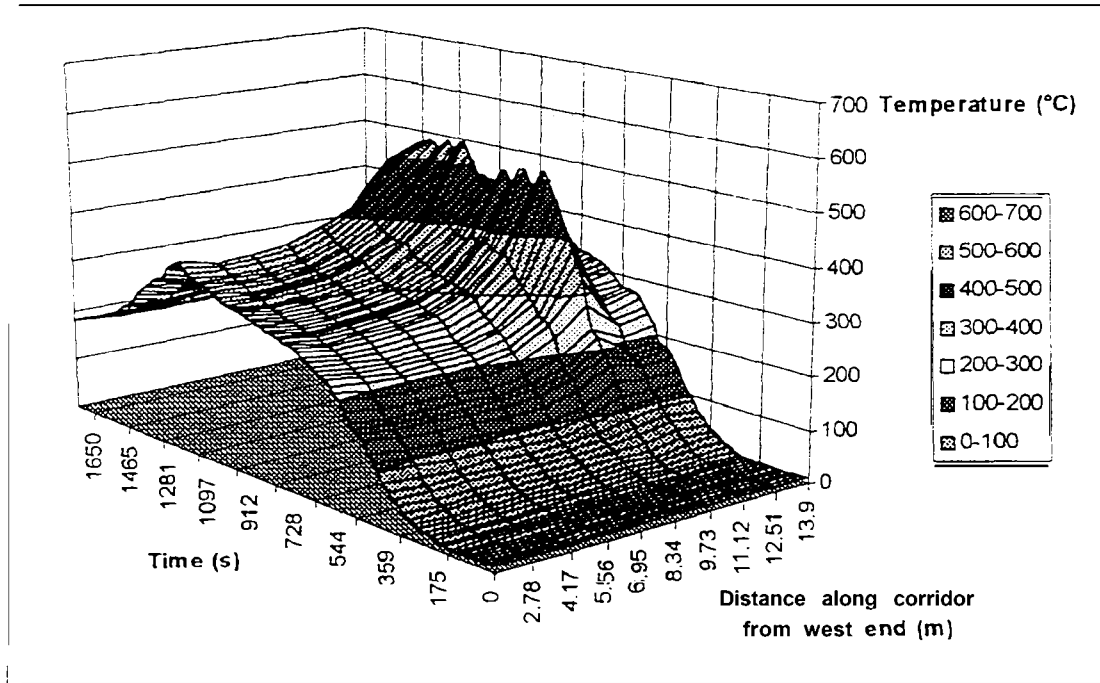

Figure FO4-12: Temperature along Level 1 corridor (1.5 m above the floor)



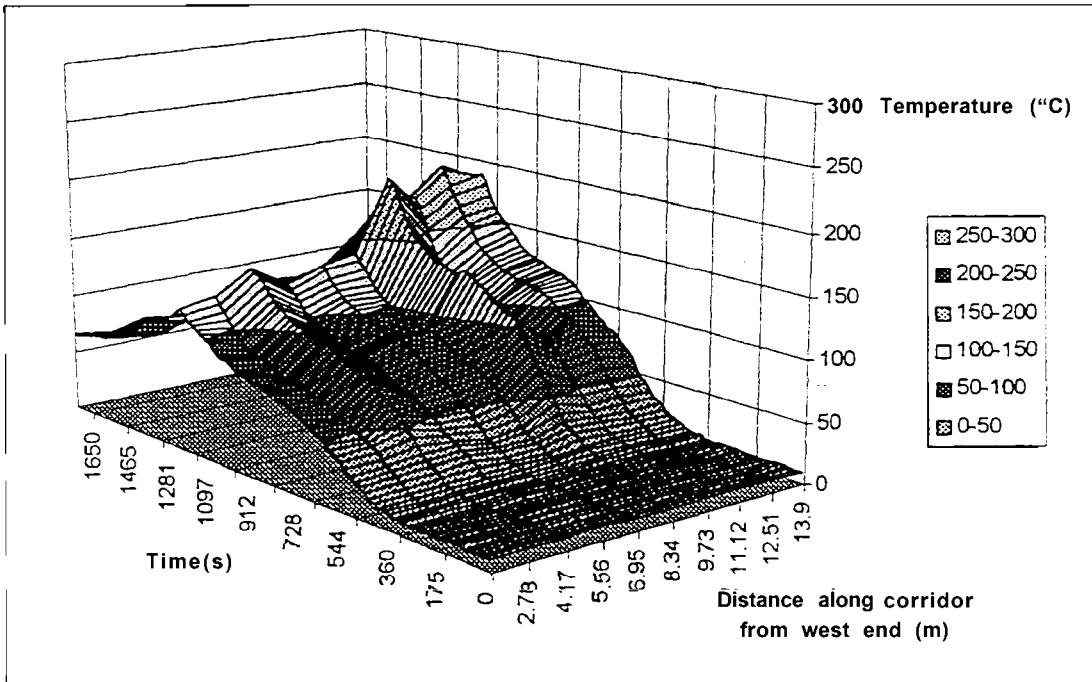

Figure FO4-13 : Temperature along Level 1 corridor (0.5 m above the floor)

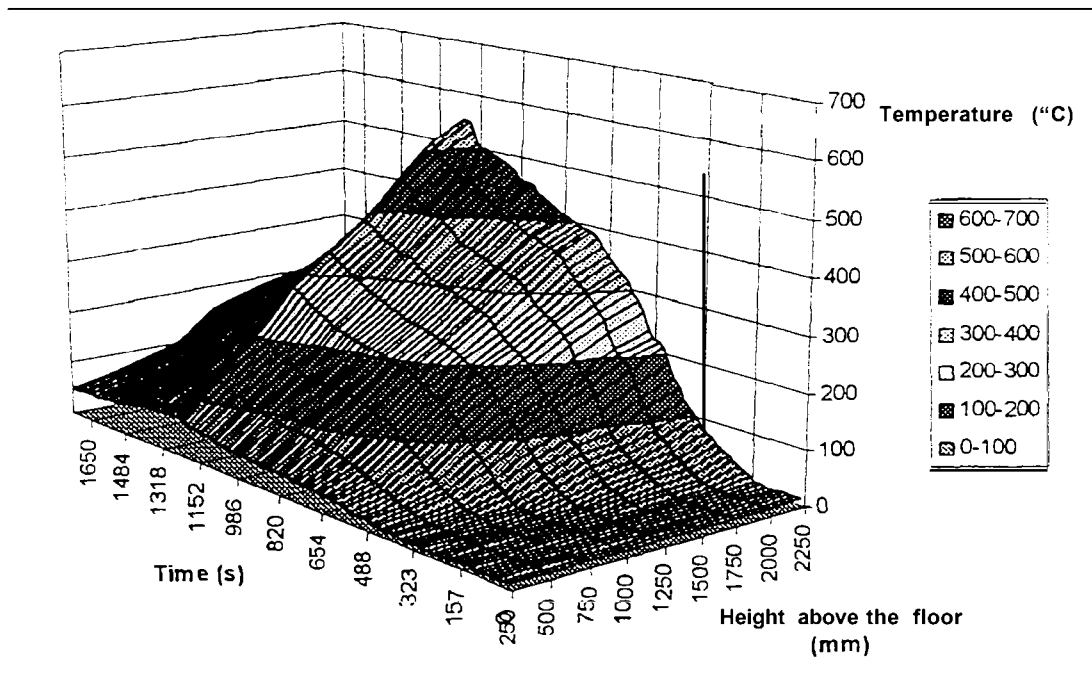

Figure FO4-14: Vertical temperature distribution in the center of Level 1 corridor

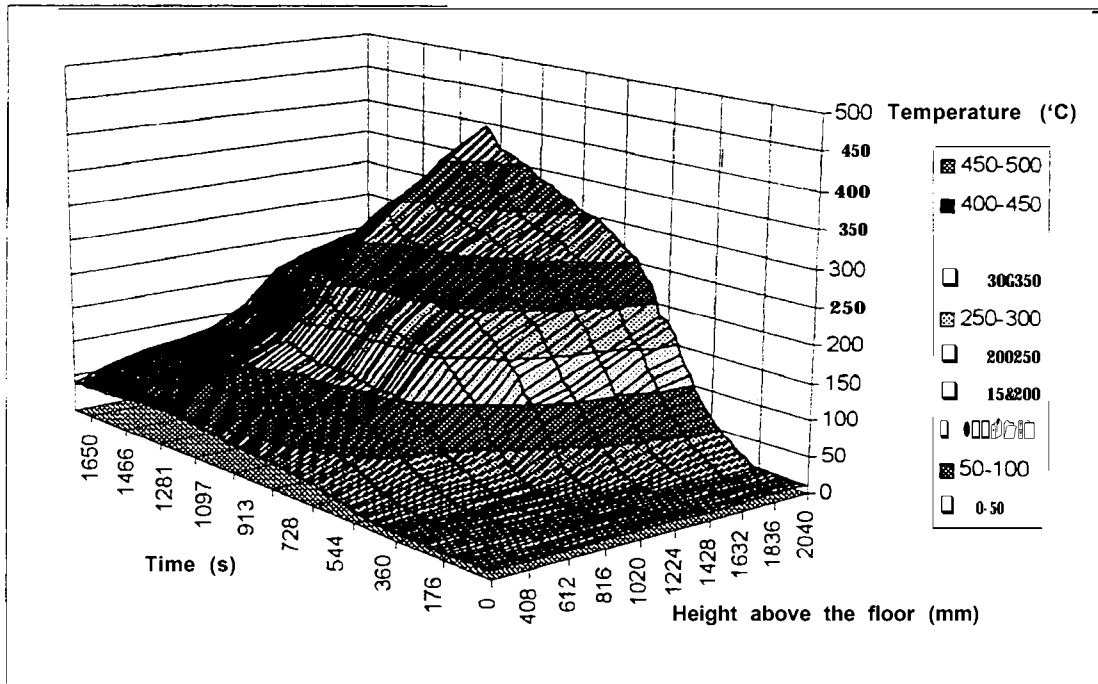

Figure FO4- 15 : Temperature distribution along the center line of Level I stairwell door

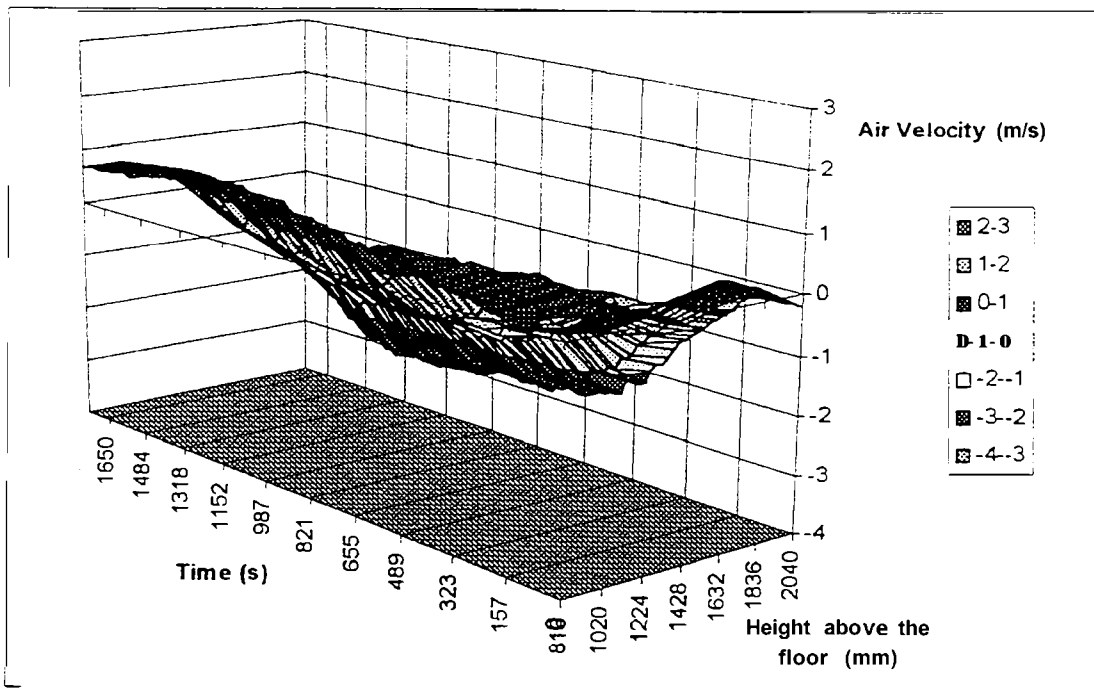

Figure FO4-16: Flow velocity distribution at the center line of Level I stairwell door

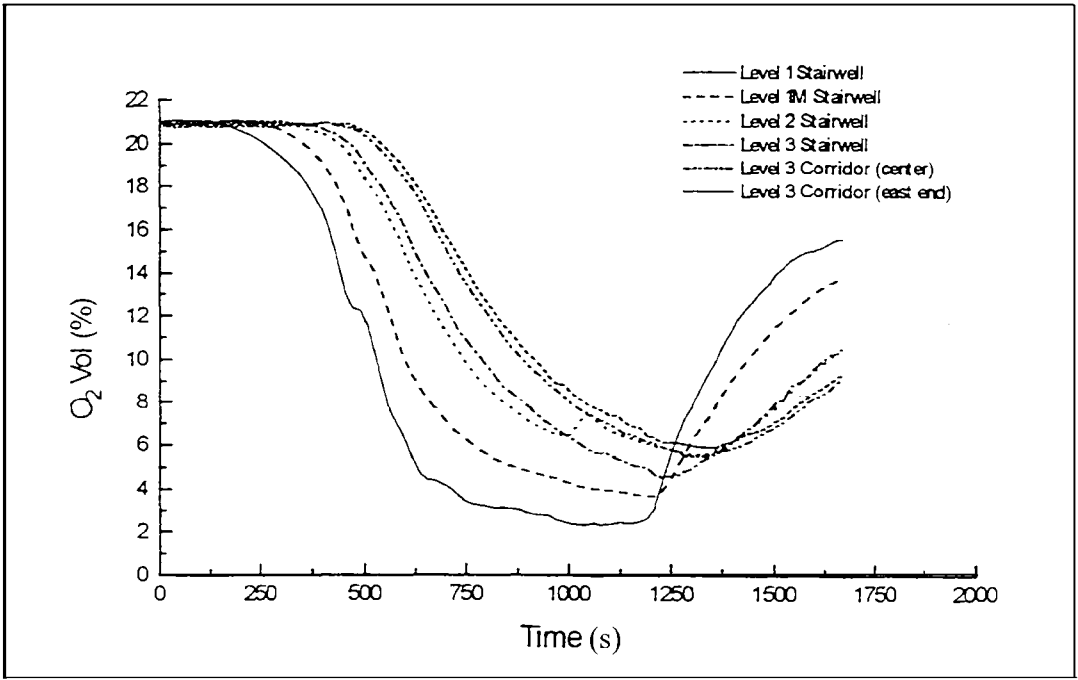

Figure FO4- 17: Oxygen concentration at the stairwell doors (1.7 m above the floor)

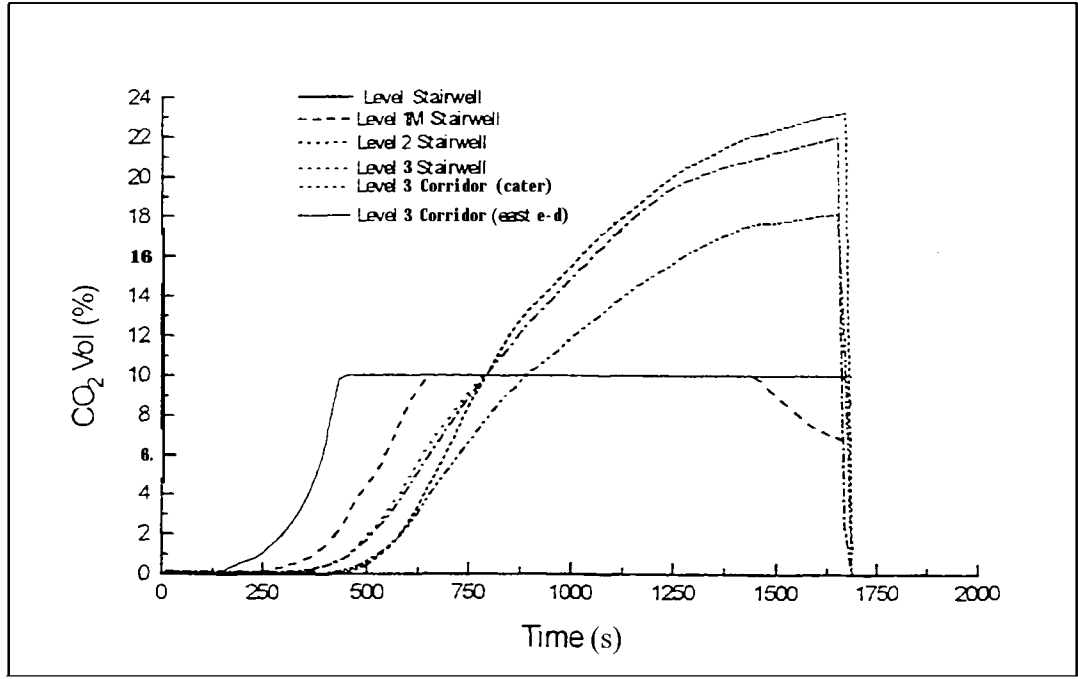

Figure FO4-18: Carbon dioxide concentration at the stairwell doors (1.7 m above the floor)

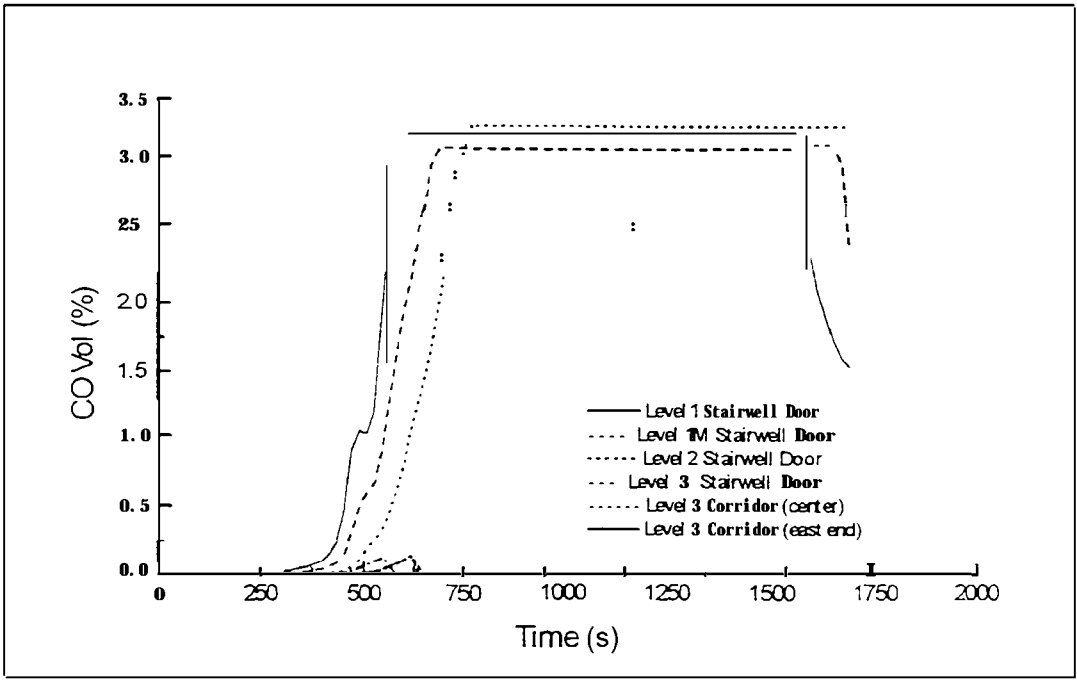

Figure FO4- 19: Carbon monoxide concentration at the stairwell doors (1.7 m above the floor)

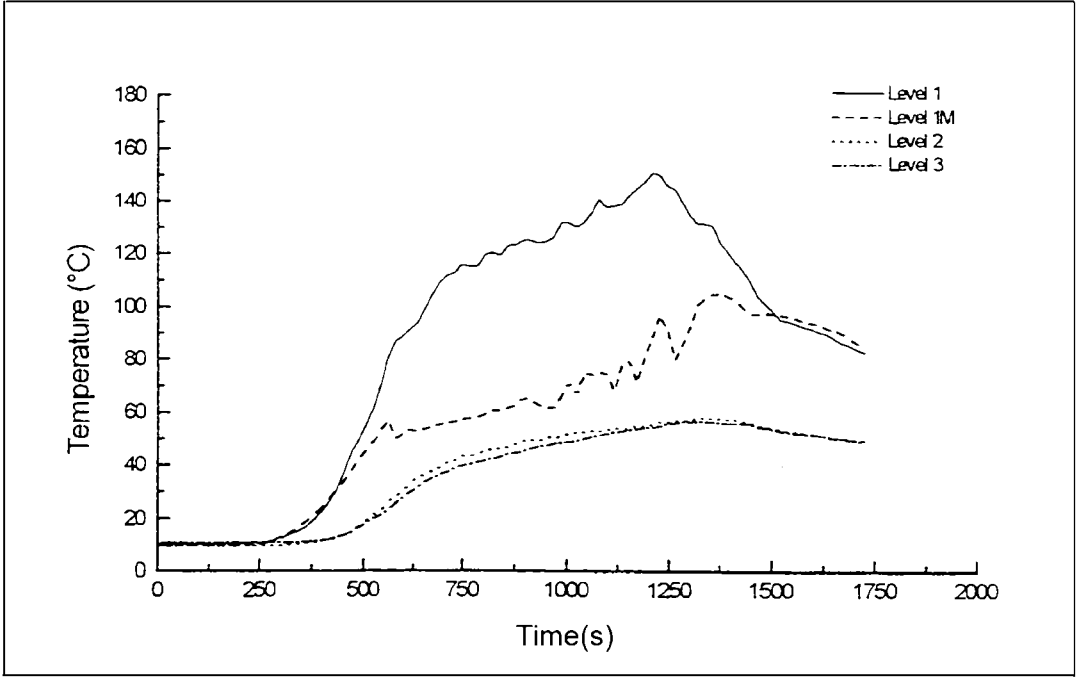

Figure FO4-20: Temperature in the stairwell at each level -North side (1.7 m above the floor)

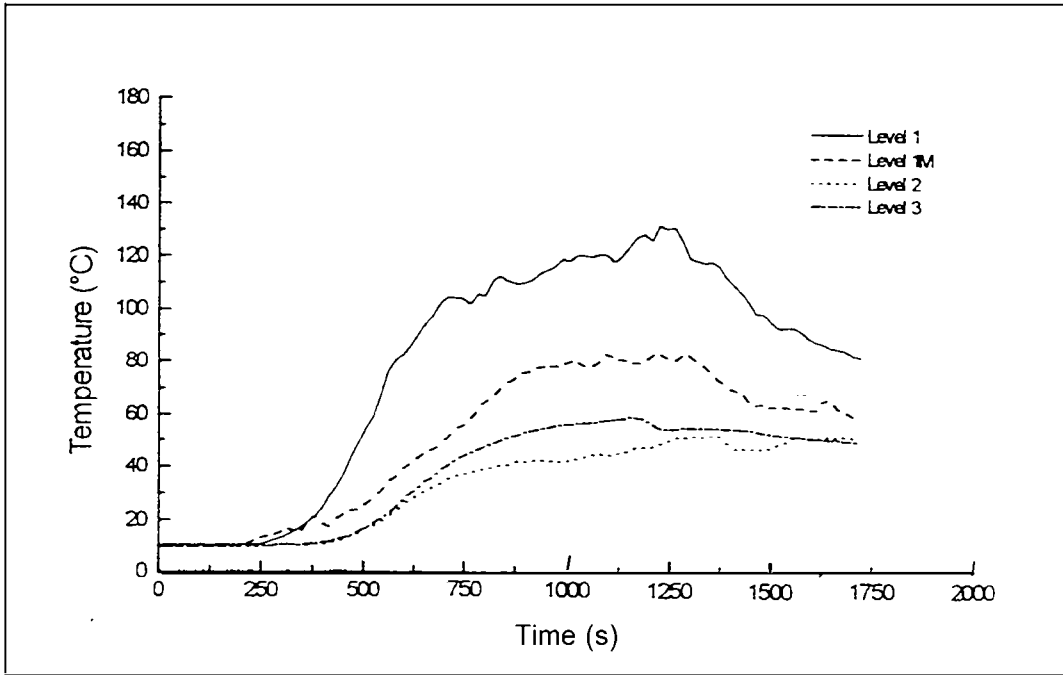

Figure FO4-21: Temperature in the stairwell at each level-South side (1.7 m above the floor)

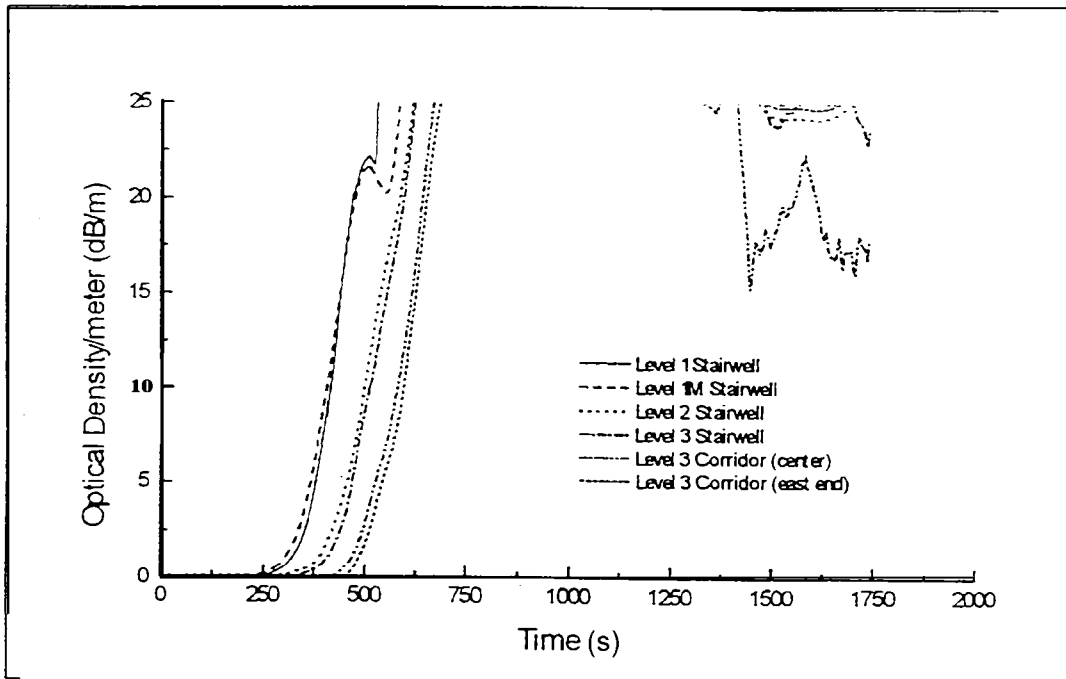

Figure FO4-22: Optical density/m at six locations (1.7 m above the floor)

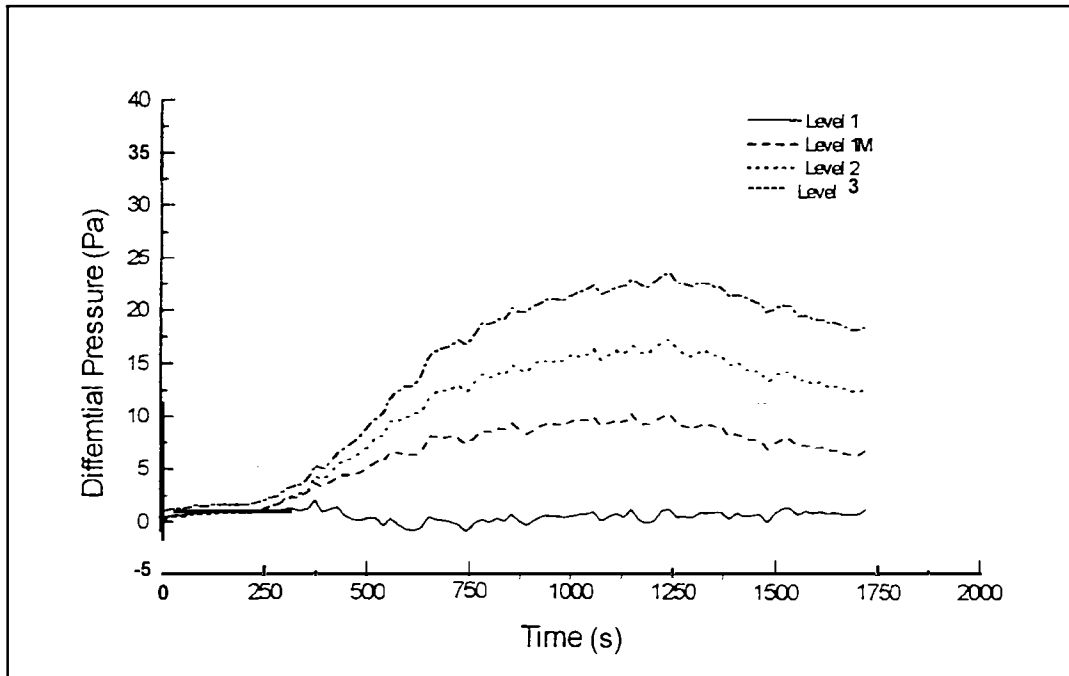

Figure FO4-23: Pressure differences between outside and the stairwell at each level (1.7 m above the floor)

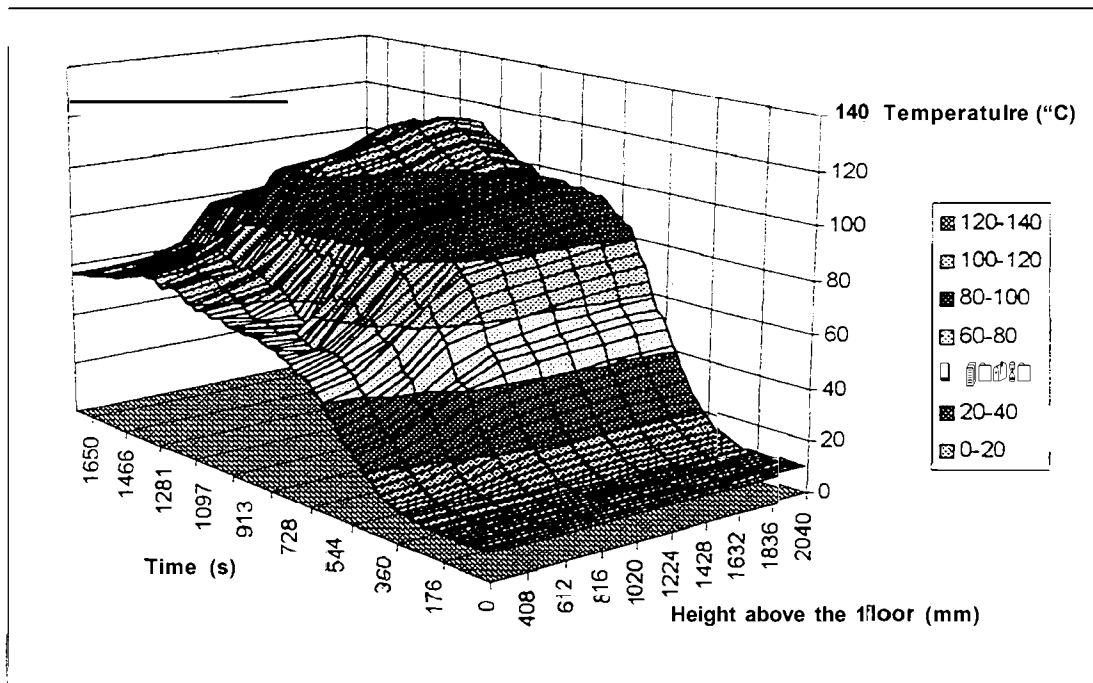

Figure FO4-24: Temperature distribution along the center line of Level 1M stairwell door

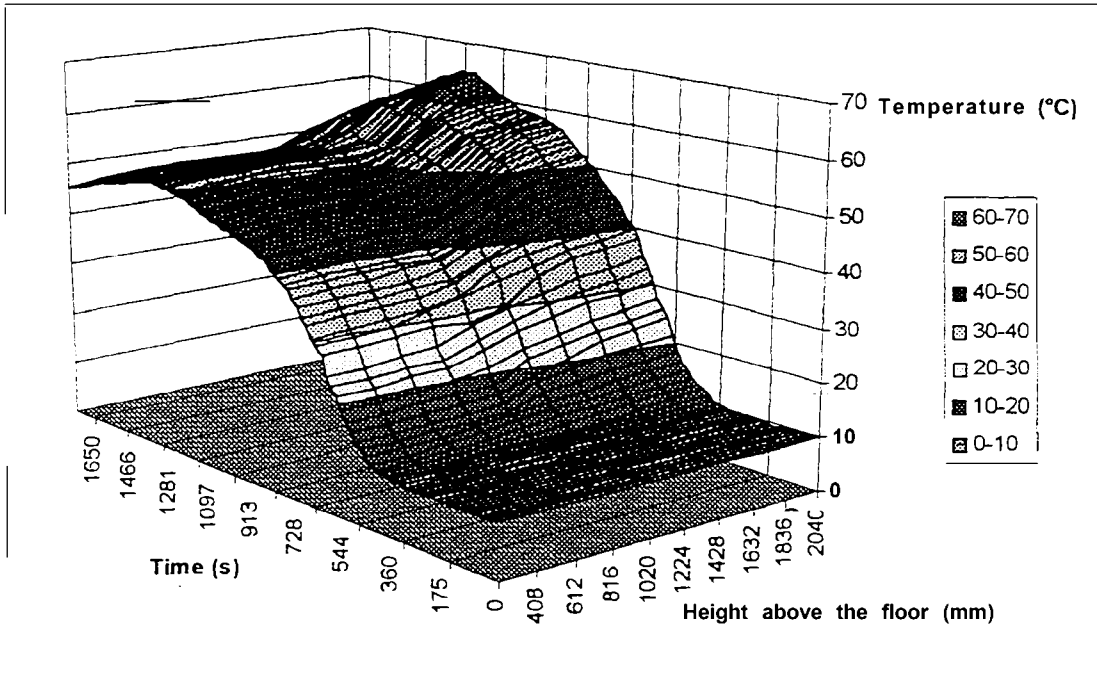

Figure FO4-25: Temperature distribution along the center line of Level 2 stairwell door

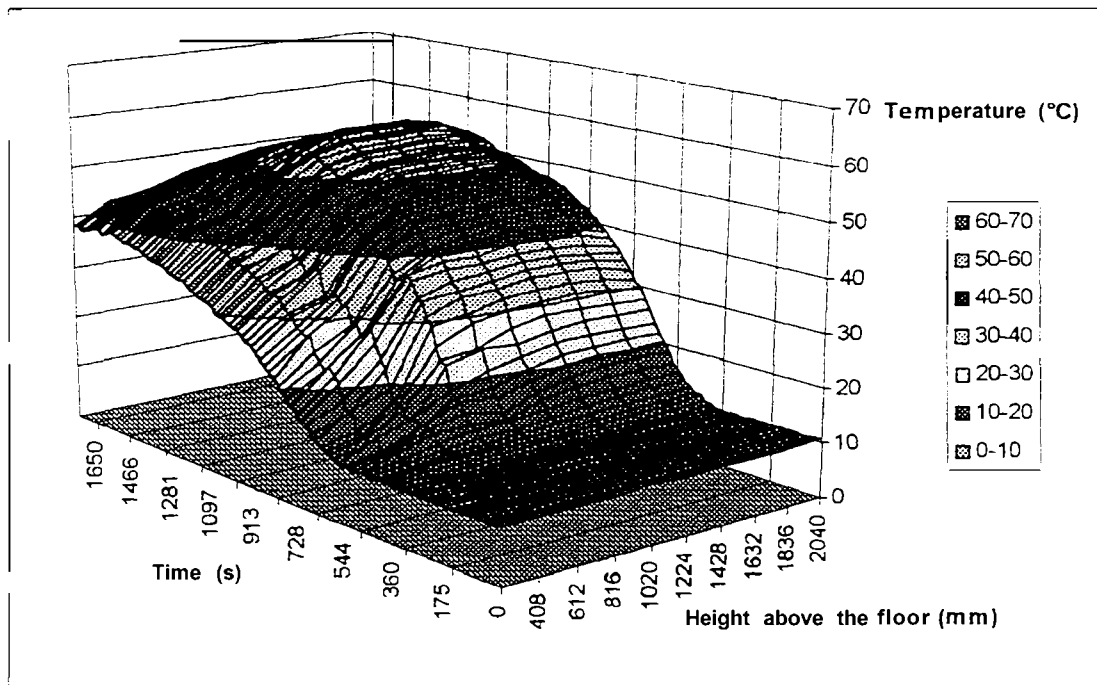

Figure FO4-26: Temperature distribution along the center line of Level 3 stairwell door

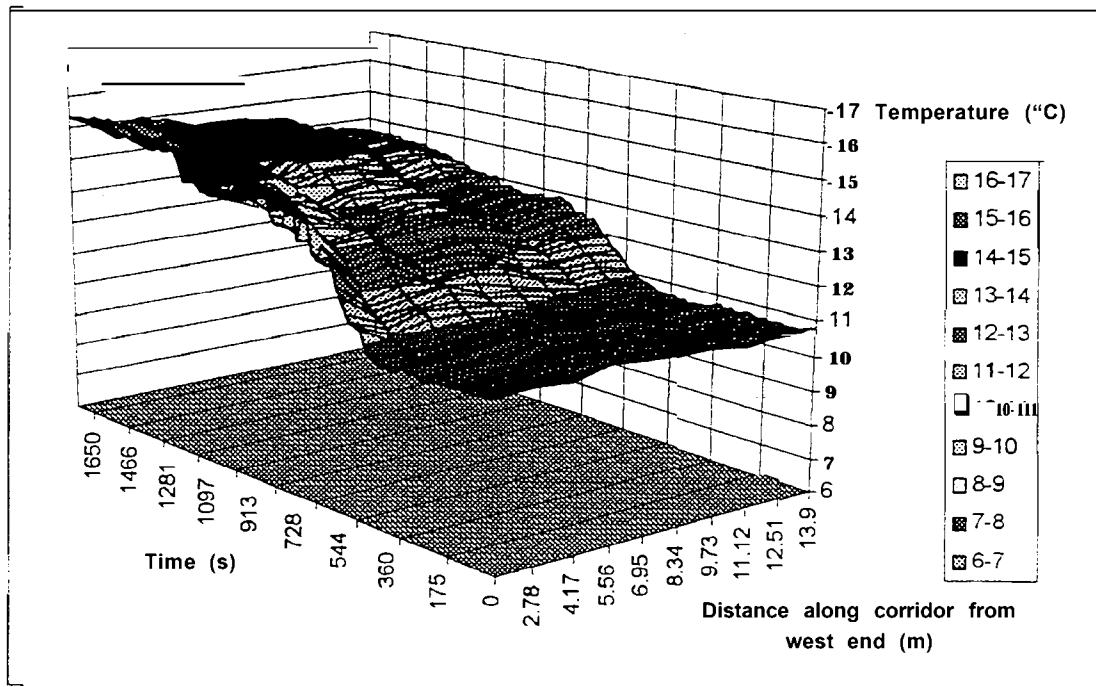

Figure FO4-27: Temperature distribution along Level 1M corridor (1.7 m above the floor)

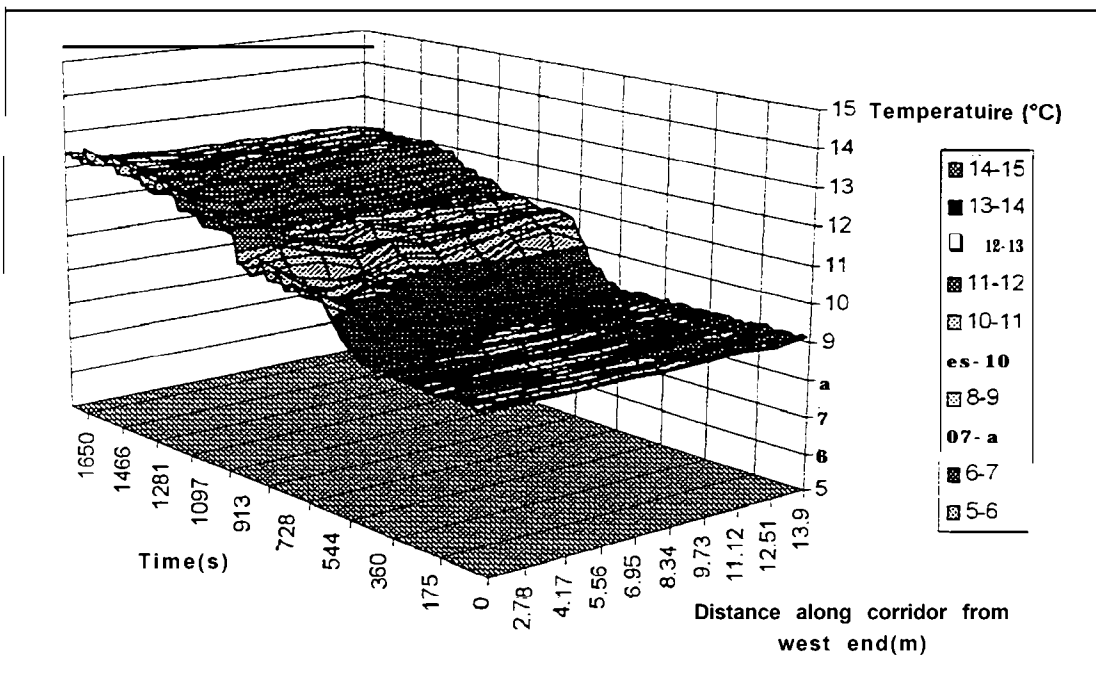

Figure FO4-28: Temperature distribution along Level 2 corridor (1.7 m above the floor)



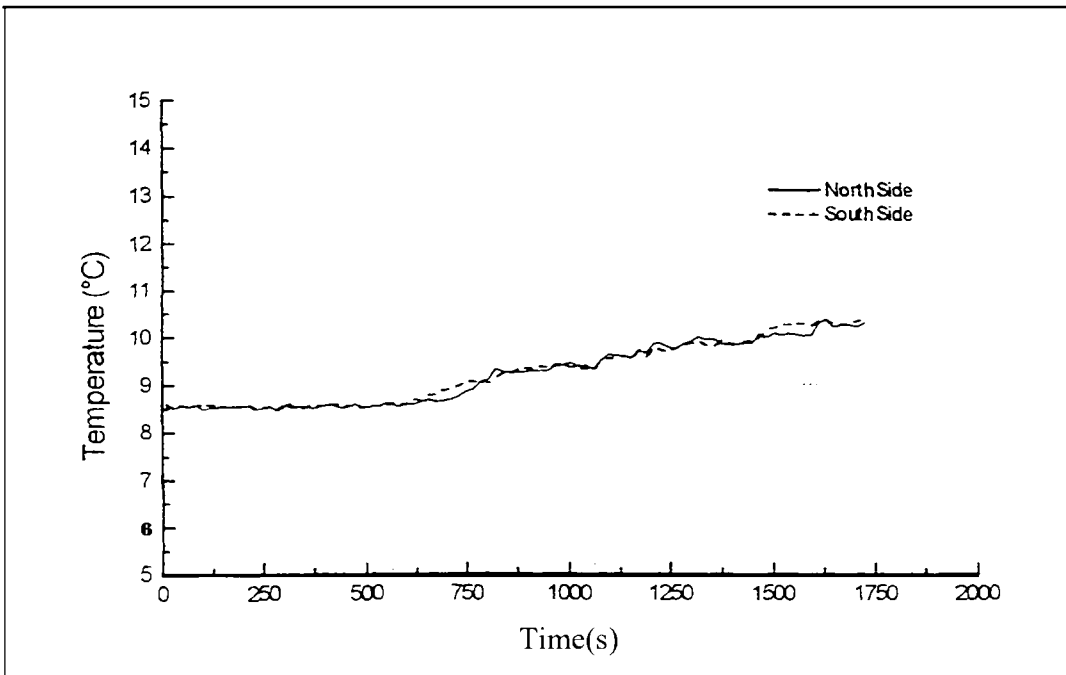

Figure FO4-29: Temperatures in Room 20 1 (1.7 m high)

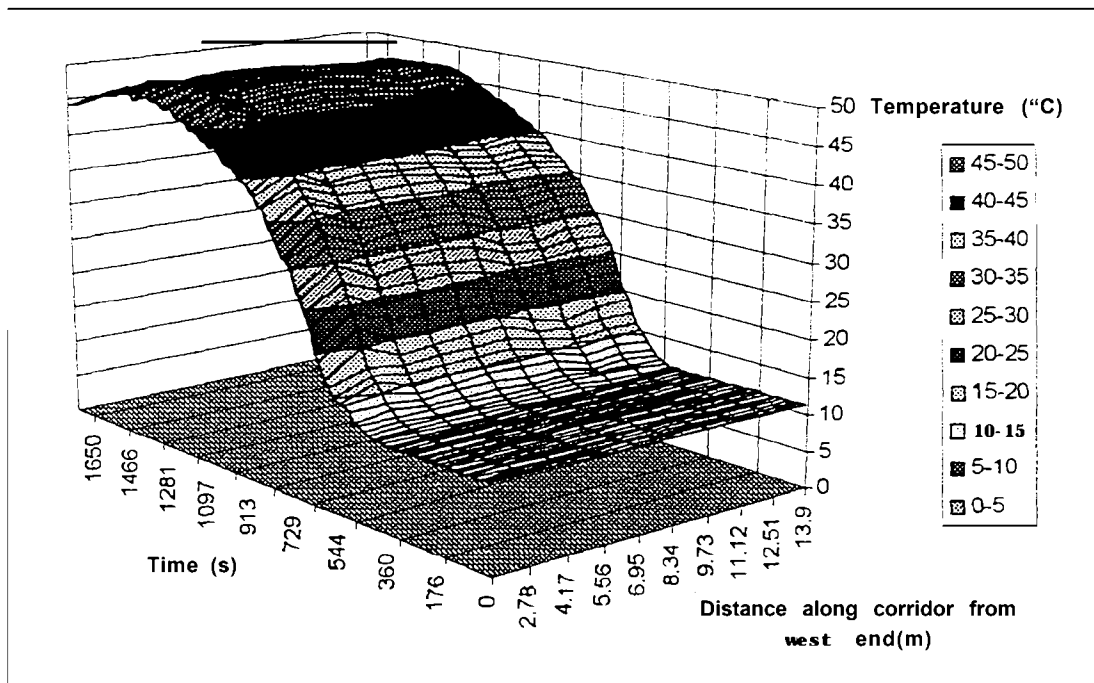

Figure FO4-30: Temperature distribution along Level 3 corridor (1.7 m above the floor)

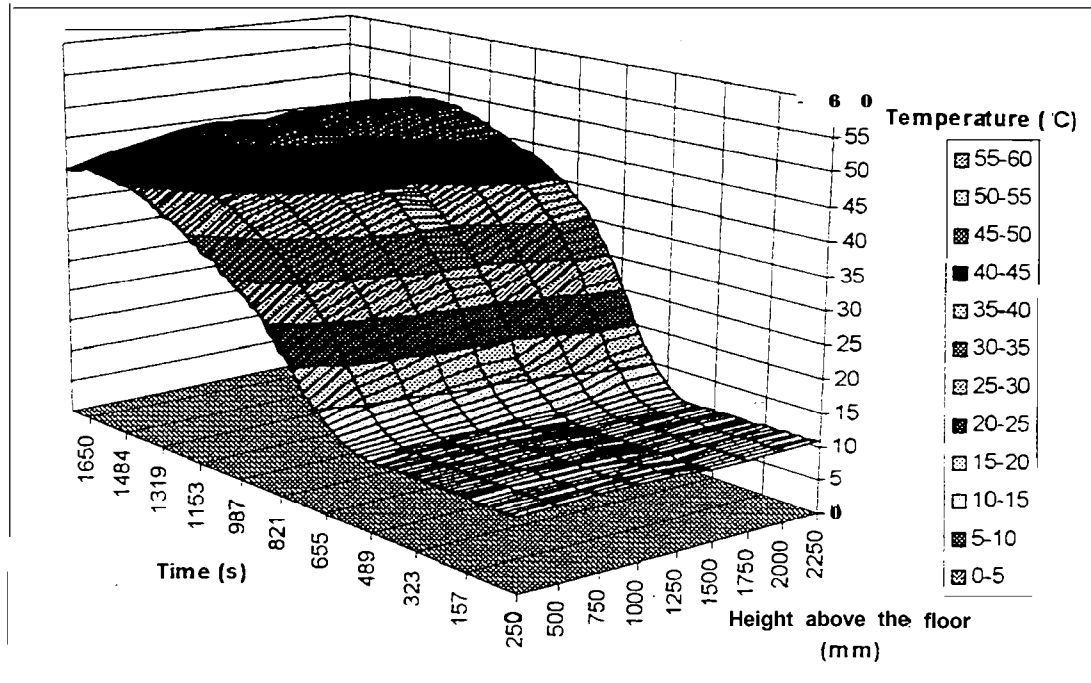

Figure FO4-31: Vertical temperature distribution in the center of Level 3 corridor

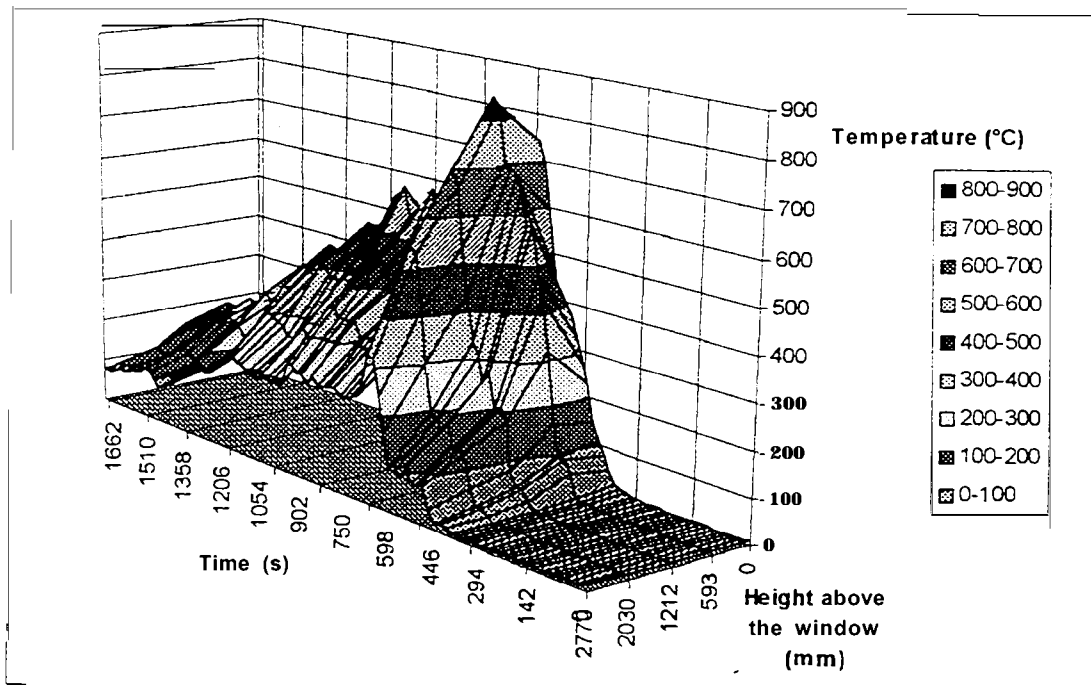

Figure FO4-32: External temperature along the center line of the bum room window (0.02 m from the wall)

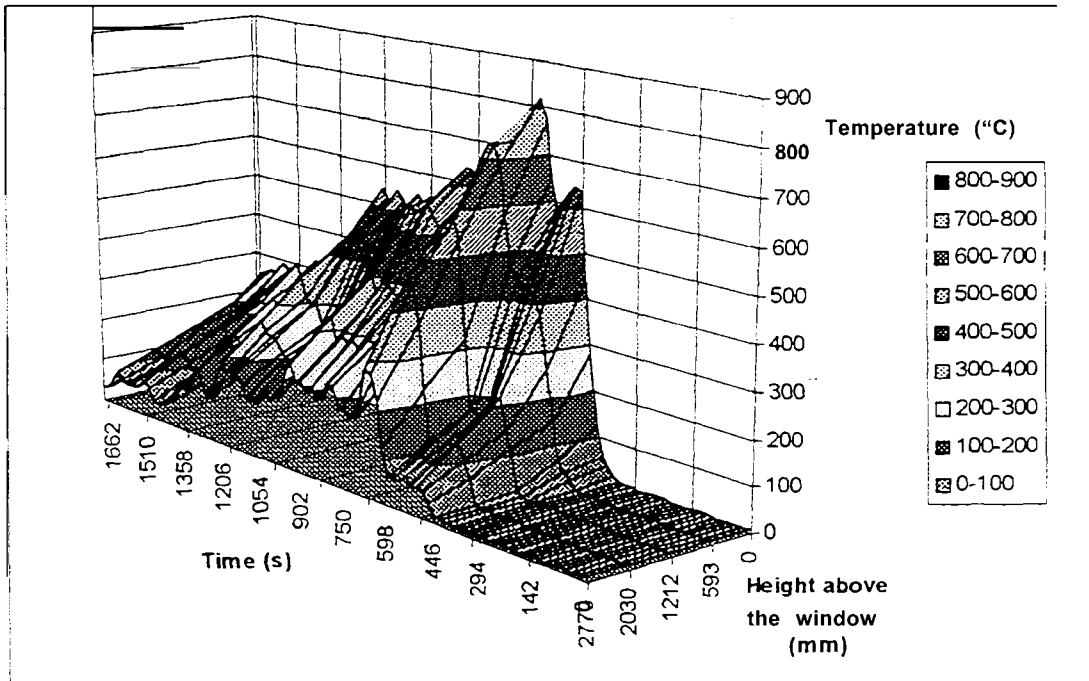

Figure FO4-33: External temperature along the center line of the bum room window (0.5 m from the wall)

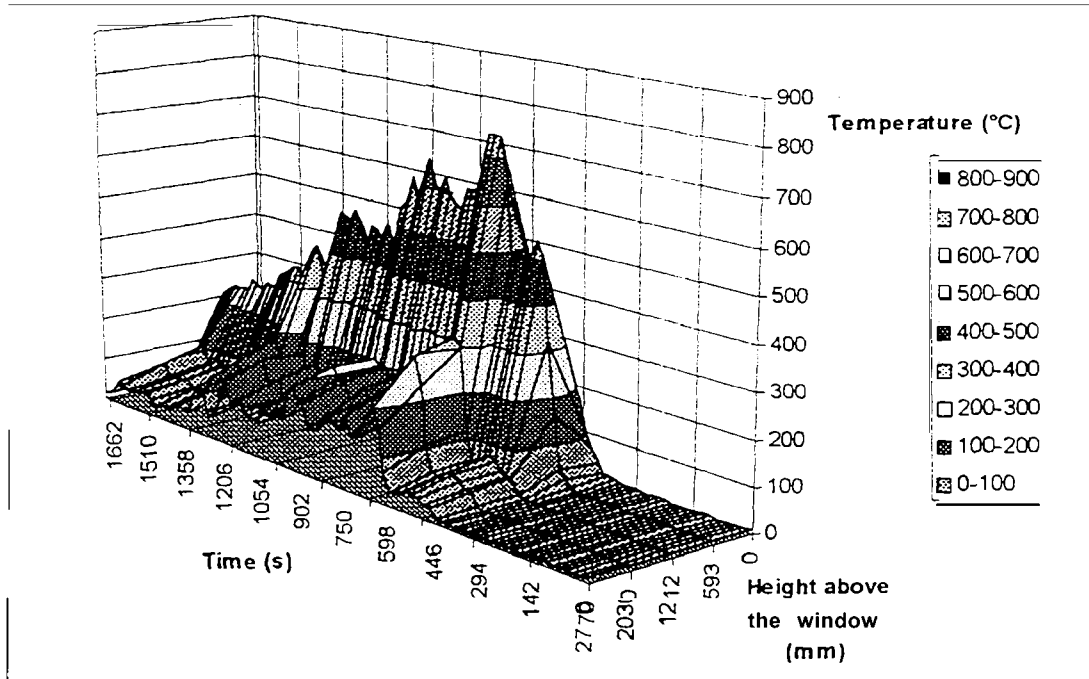

Figure FO4-34: External temperature along the center line of the bum room window (1.0 m from the wall)

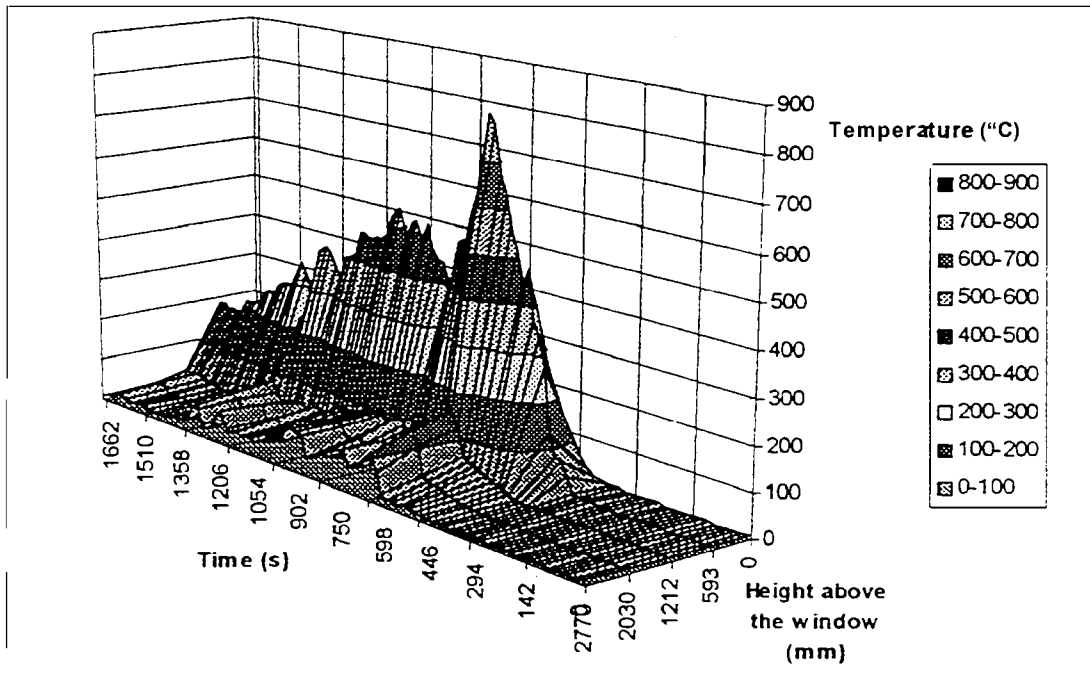

Figure FO4-35: External temperature along the center line of the bum room window (1.5 m from the wall)

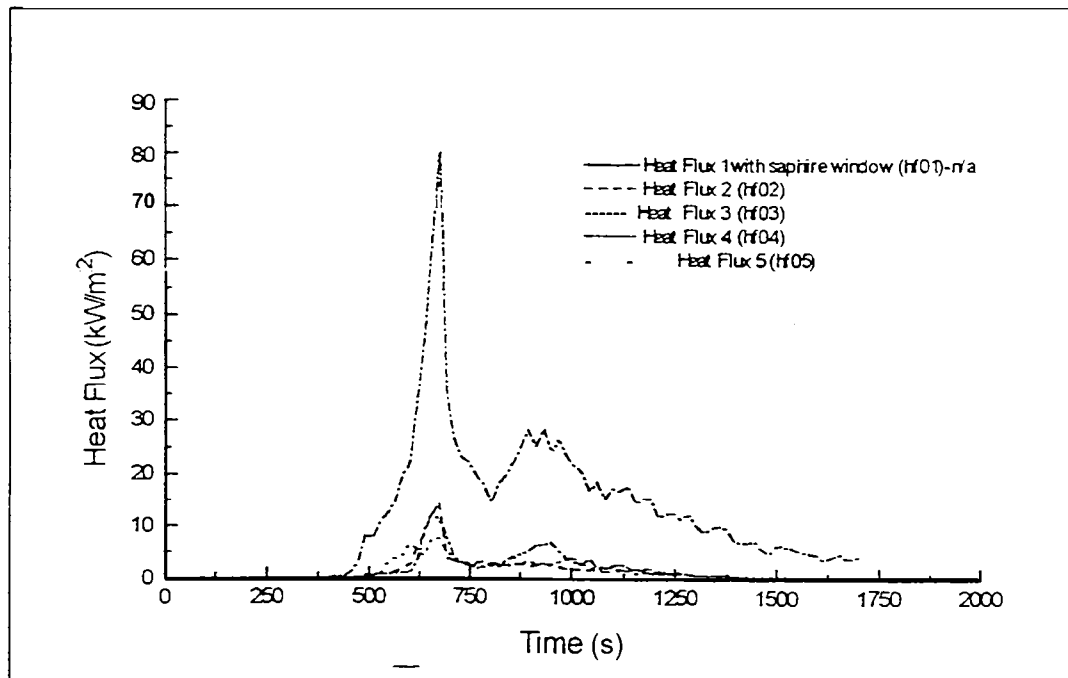

Figure FO4-36: External heat flux measurements (Refer to Figure 25 for locations)

### 13. Flashover Test F05

**Test Conditions:**     **Burn Room Door Open**  
                               **Level 1 Stairwell Door Open**  
                               **Smoke Management and Stair Pressurisation ON**

**Observations:**

- 0:00 Ignition
- 0:55 Ionisation detector (no cap) activated
- 2:40 Photo-optical detector in return air duct activated  
Smoke management and stair pressurisation systems activated
- 3:50 Significant bowing of the window
- 4:35 Initial crack in middle pane
- 5:00 Sprinkler (quick response) above the small platform activated (detection only)
- 5:15 Smoke layer reaching the top of the window (0.4 m from the ceiling)
- 5:40 Sprinkler above the large platform activated (detection only)
- 5:48 Dislodgment of left and middle pane  
*(glass thermocouples fell off before criteria was reached, so fire was allowed to progress without intervention)*
- 7:00 Flames are coming out the window in almost a horizontal manner up to 0.5 m high above the window opening
- 7:40 Right pane dislodgment- 90% of bum room window dislodged by this stage  
Fire is still contained to the couch and the surrounding carpet
- 10:30 Fire is starting to die out; although there is still a lot of smoke coming out of the window, there are no flames
- 12:30 Very little smoke coming out of window

Although there was dislodgment early in the fire test, F05 did not proceed to flashover due to the combined effect of the smoke management and stair pressurisation sub systems and only the couch and surrounding carpet were consumed by the fire. No breakage of upper windows occurred and the sprinkler in Level 1 corridor did not activate. The P/U and the carpet in Level 1 corridor were unaffected by the fire.

**Table 11: Summary of results for Test F05**

<b>In the Bum Room</b>	
Maximum Heat Release Rate	3.0 MW
Maximum Peak Temperature	336 °C
Maximum Average Room Temperature	168°C
Minimum Oxygen Concentration	18 Vol %
Maximum Total Heat Flux	11 kW/m <sup>2</sup>
Time untenability reached (1 00°C)	341 s

<b>At the Burn Room Door</b>		
Maximum CO Concentration a		0.03 Vol %
Maximum CO <sub>2</sub> Concentration		1.0 Vol %
Maximum Temperature		147 °C
Minimum Oxygen Concentration		<b>20</b> Vol %
<b>In Level 1 Corridor</b>		
Maximum Temperature 1.5 m above the floor		18 °C
Maximum Temperature in the center of the Corridor		<b>37</b> °C
<b>Stairwell</b>		
Maximum Temperature	Level 1	7 °C
	Level 1M	<b>6</b> °C
	Level 2	6 °C
	Level 3	7 °C
<b>Level 3 Corridor</b>		
Maximum Temperature		7 °C
<b>External</b>		
Maximum External Temperature		na °C
Maximum Total Heat Flux		8 kW/m <sup>2</sup>

Note: A full list of detector and sprinkler activation times is shown in Table 1.5 & 16  
Only the time for the first detector activated is listed in the above observations.

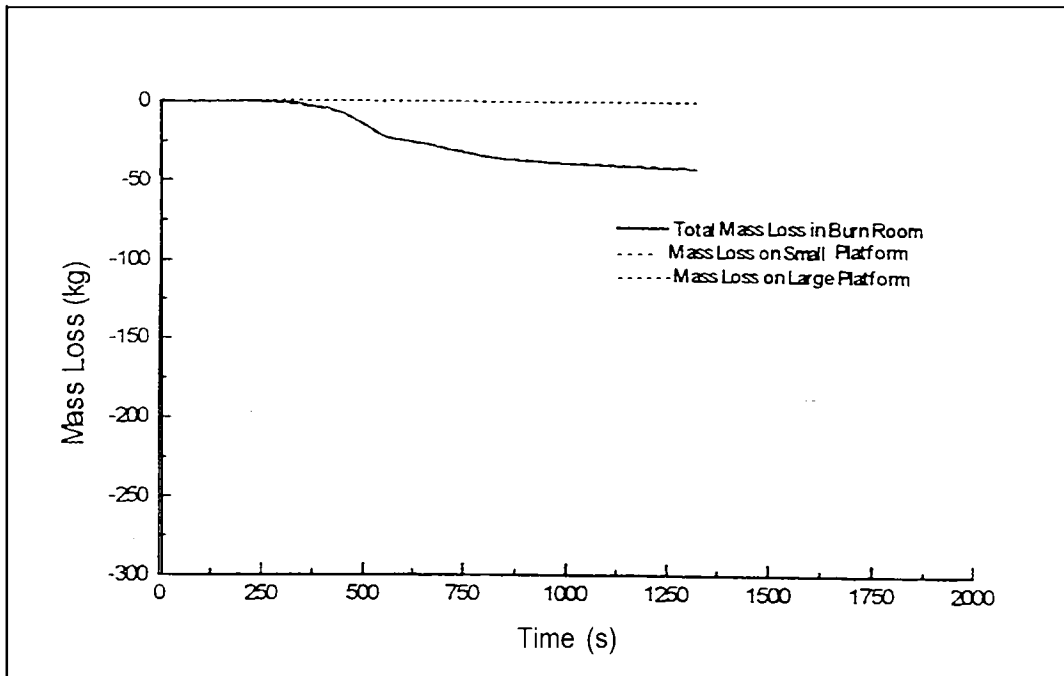

Figure FOS- 1: Combined mass loss in the bum room

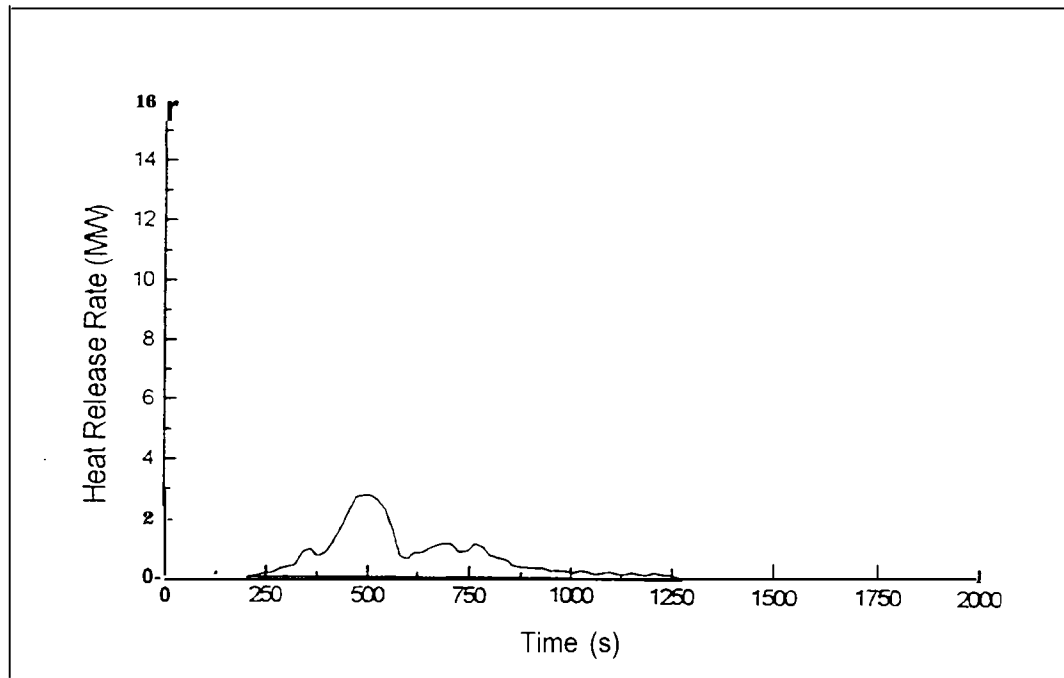

Figure FOS-2: Total heat release rate in the bum room

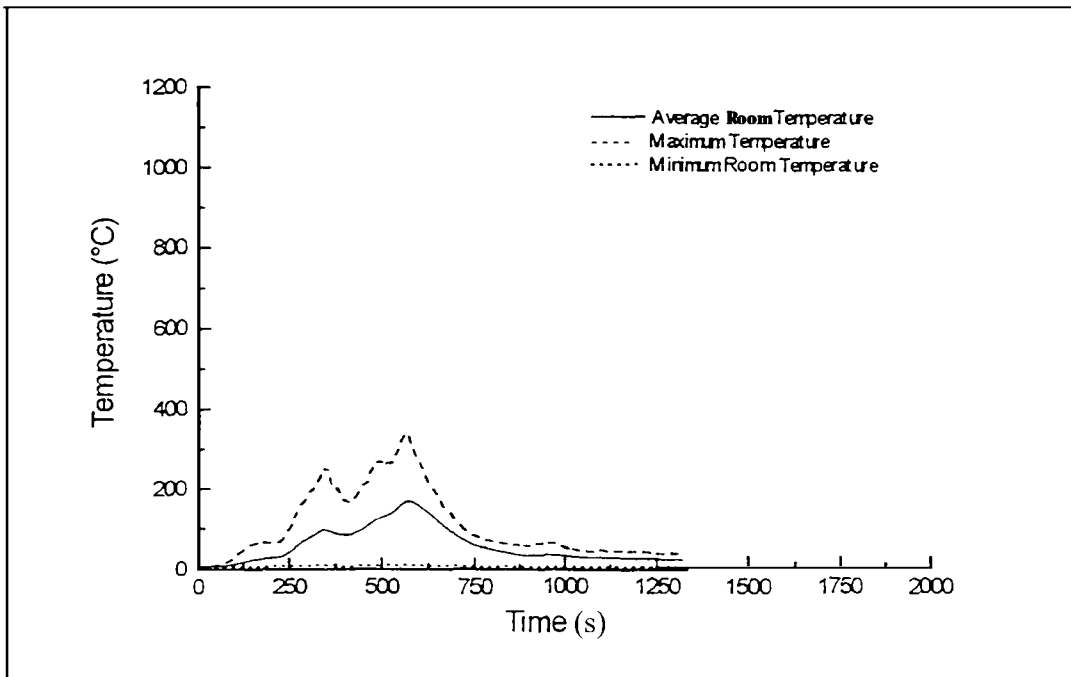

Figure FO5-3: Average, maximum and minimum temperatures in the bum room

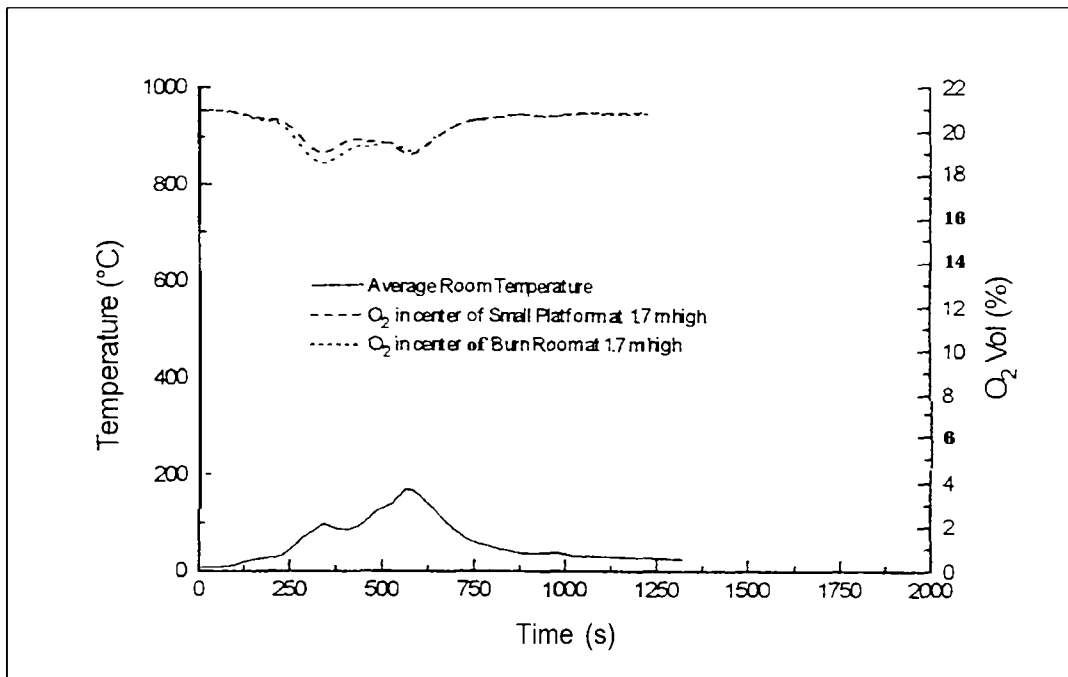

Figure FO5-4: Oxygen concentration and average temperature in the bum room



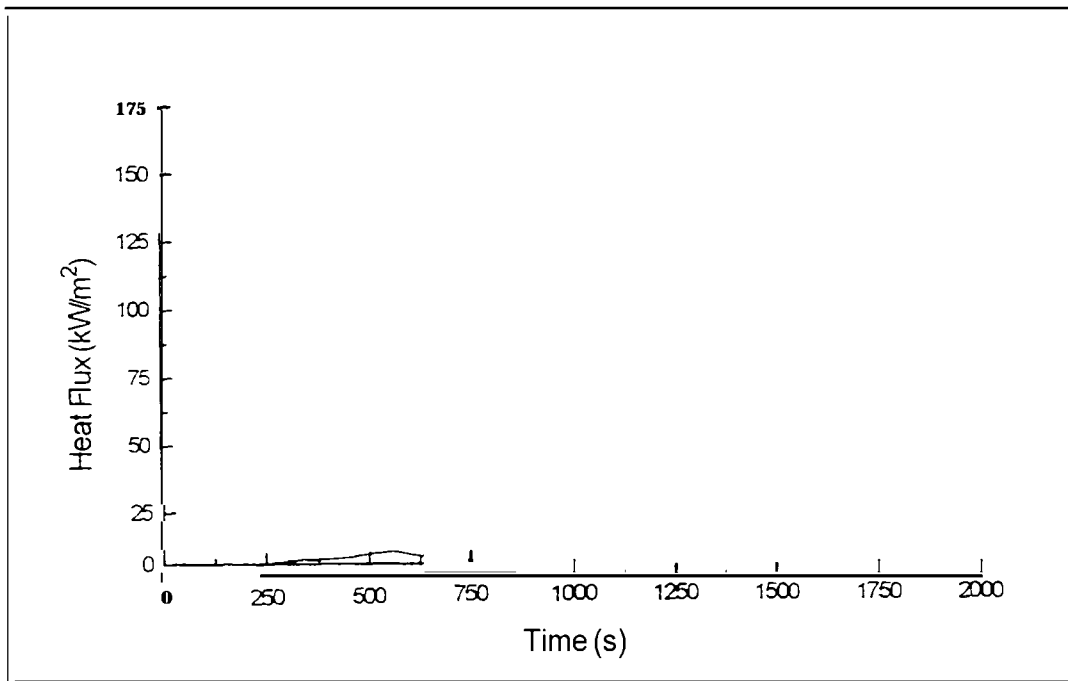

Figure FO5-5: Total heat flux in the center of the bum room

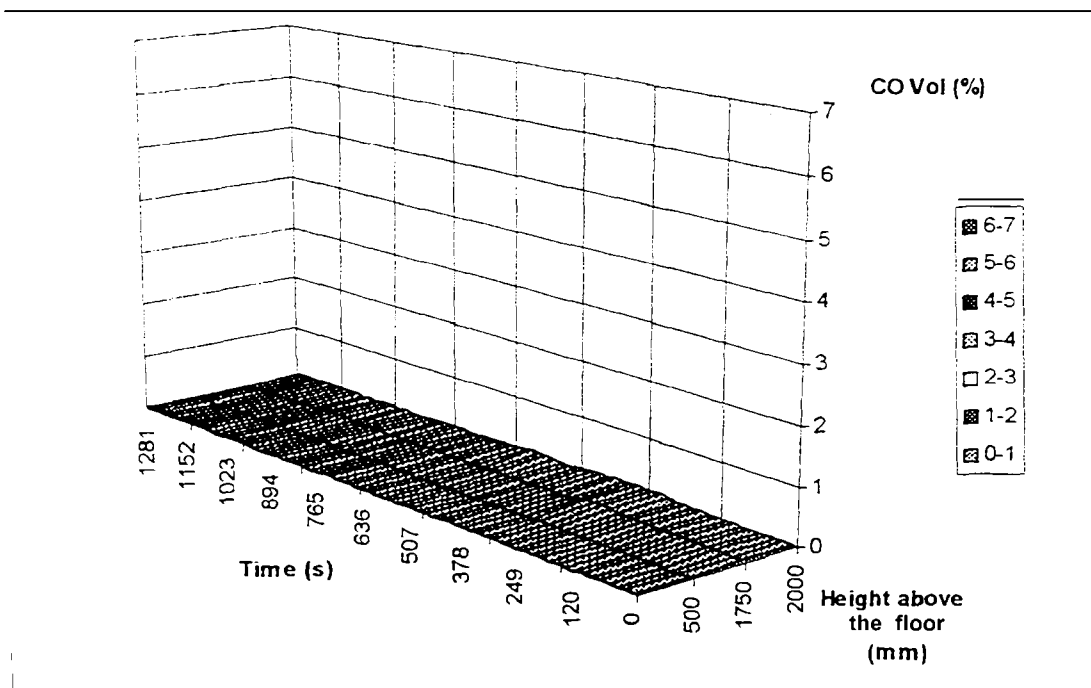

Figure FO5-6: Carbon monoxide concentration along the center line of the bum room door

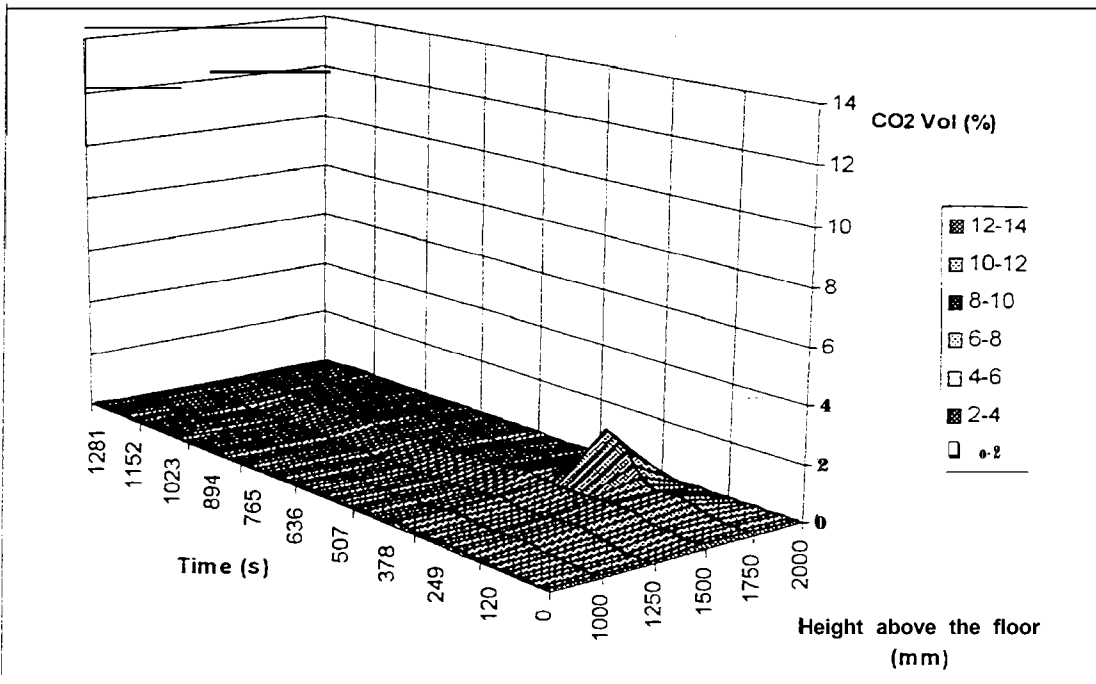

Figure FO5-7: Carbon dioxide concentrations along the center line of the bum room door

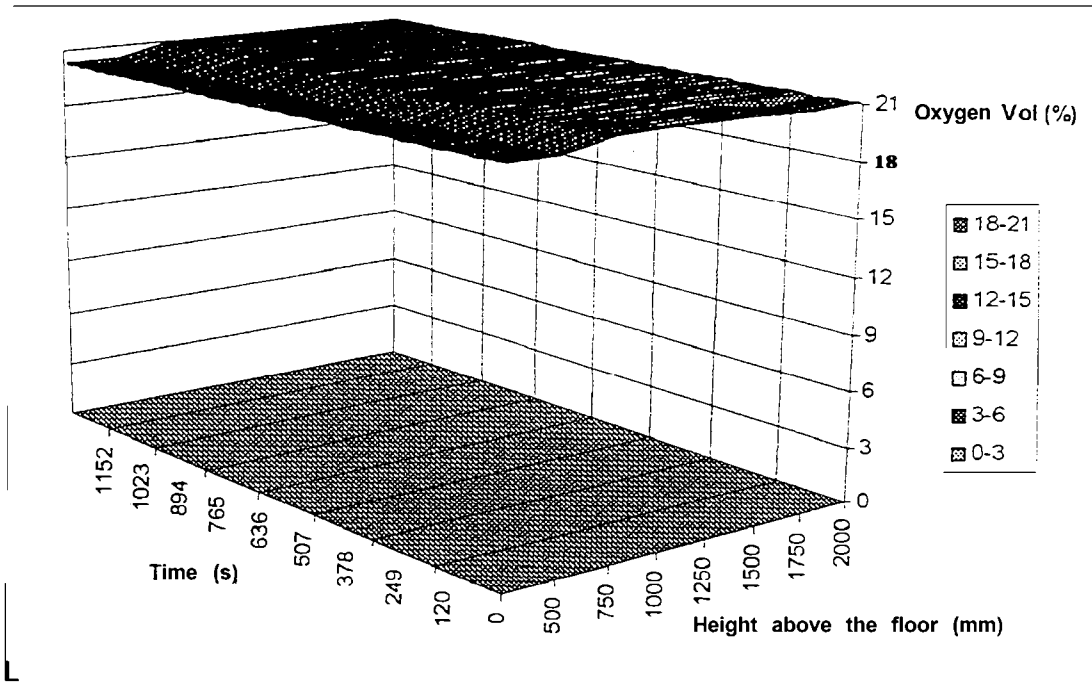

Figure FO5-8: Oxygen concentrations along the center line of the bum room door

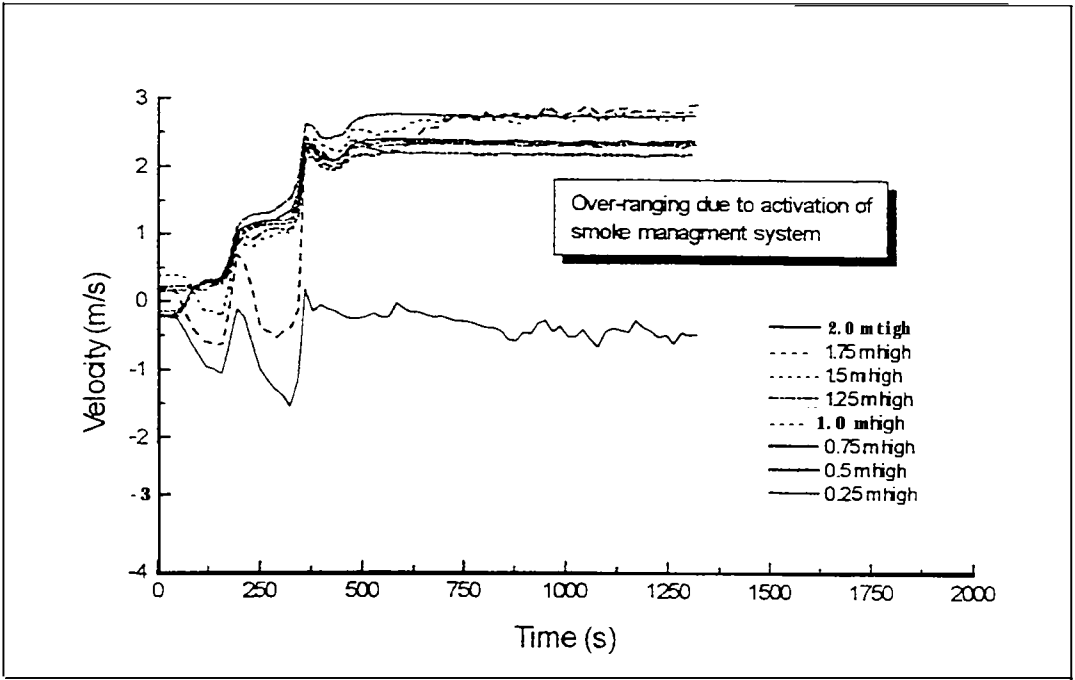

Figure FO5-9: Flow velocity distribution at the center line of the bum room door

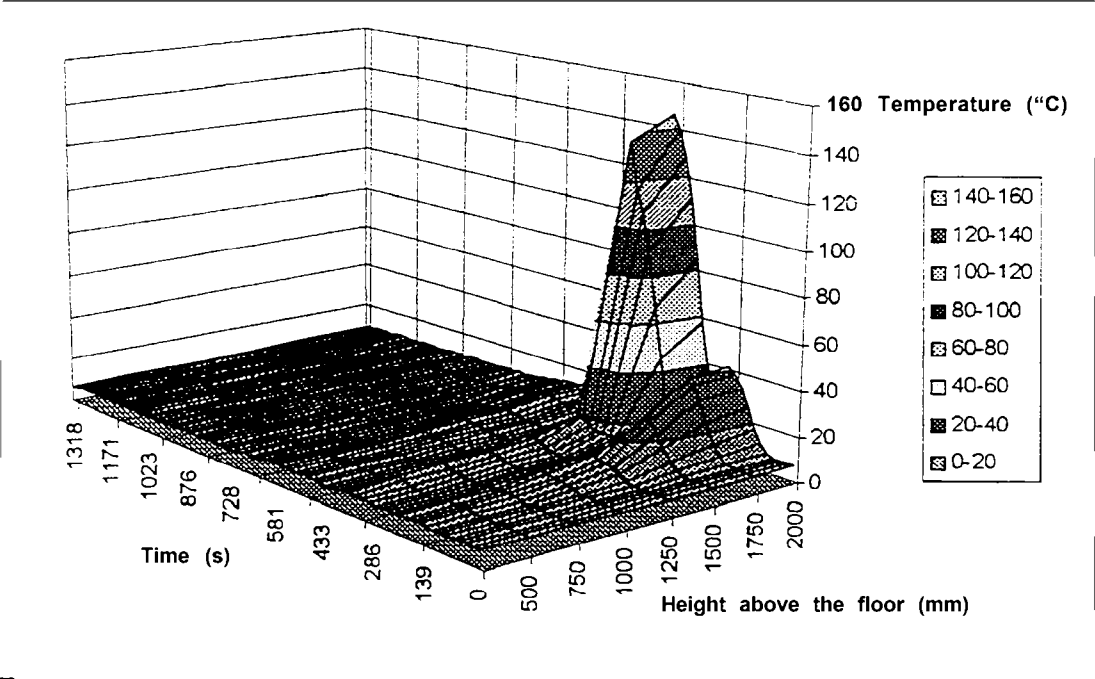

Figure FO5-10: Temperature distribution along the center line of the bum room door

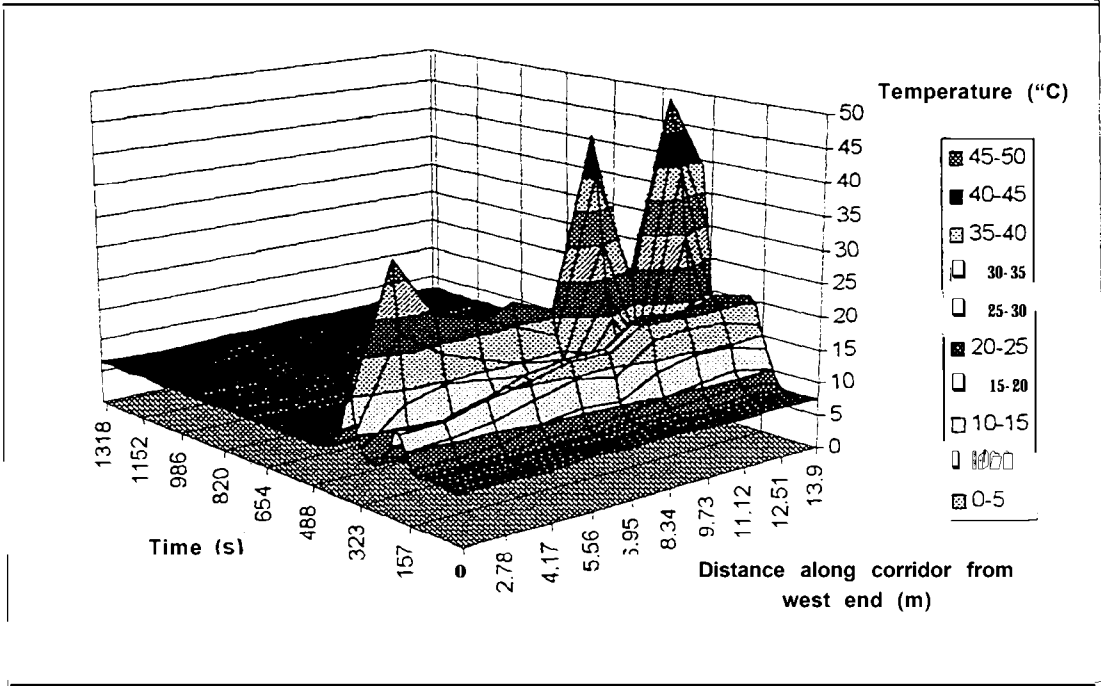

Figure FO5- 11: Temperature along Level 1 corridor (2.0 m above the floor)

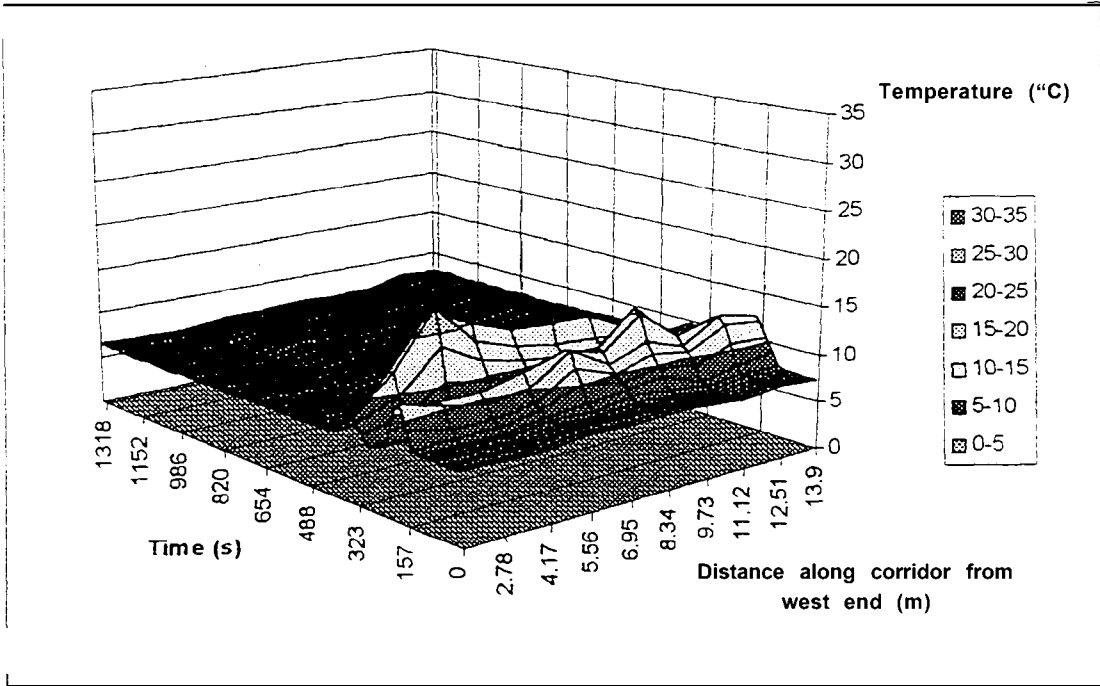

Figure FO5-12: Temperature along Level 1 corridor (1.5 m above the floor)

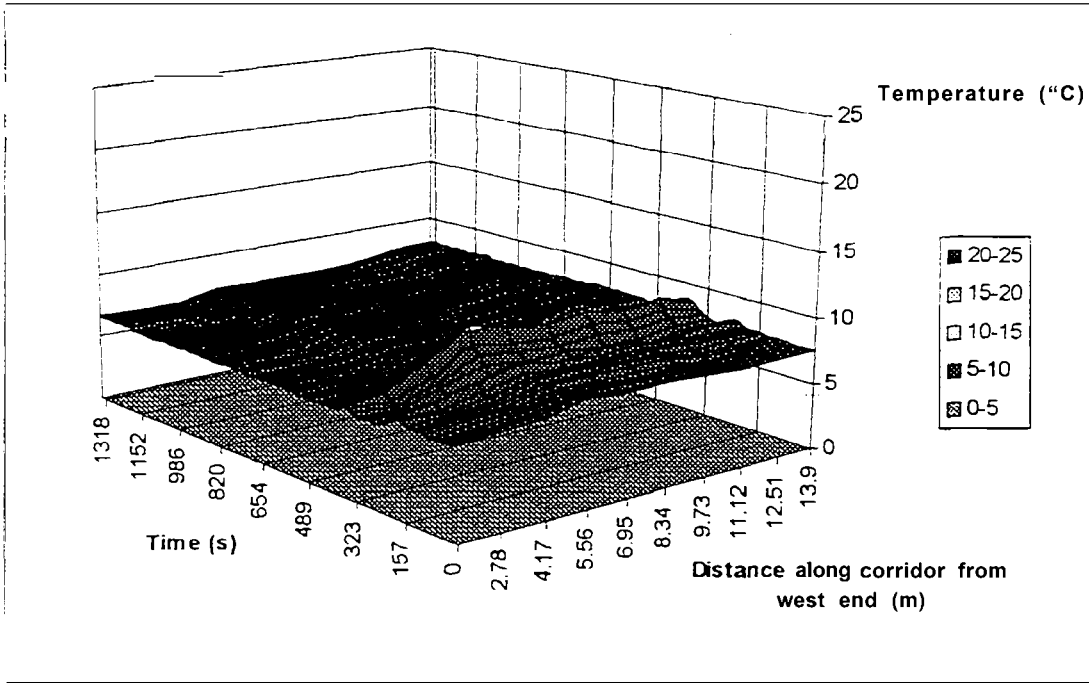

Figure FO5-13 : Temperature along Level 1 corridor (0.5 m above the floor)

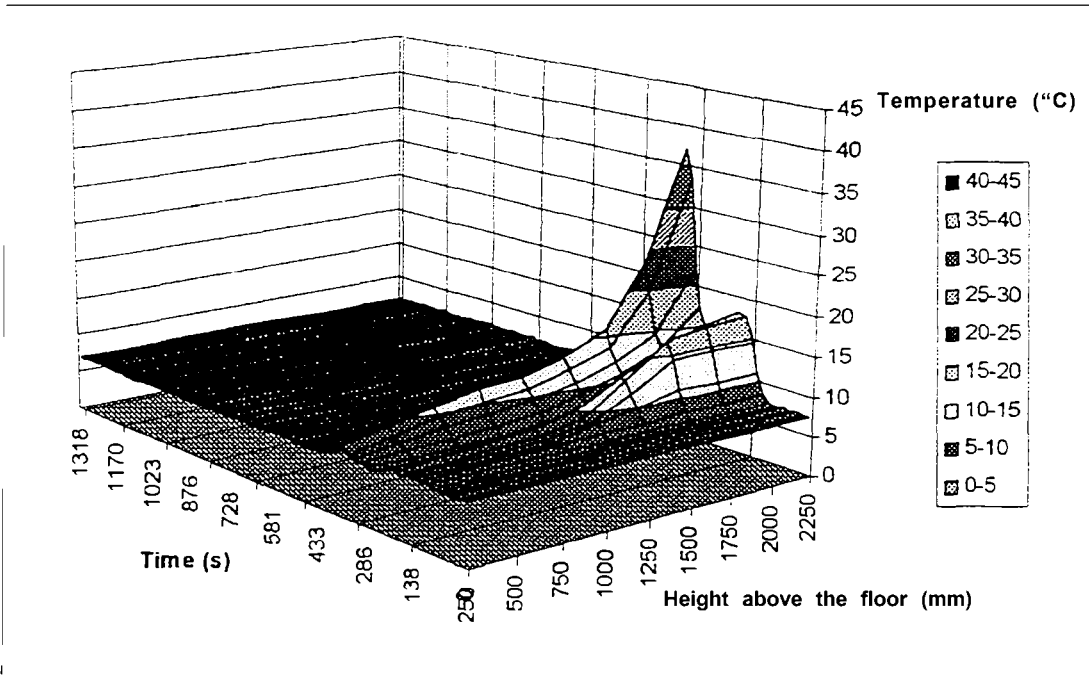

Figure FO5-14: Vertical temperature distribution in the center of Level 1 corridor

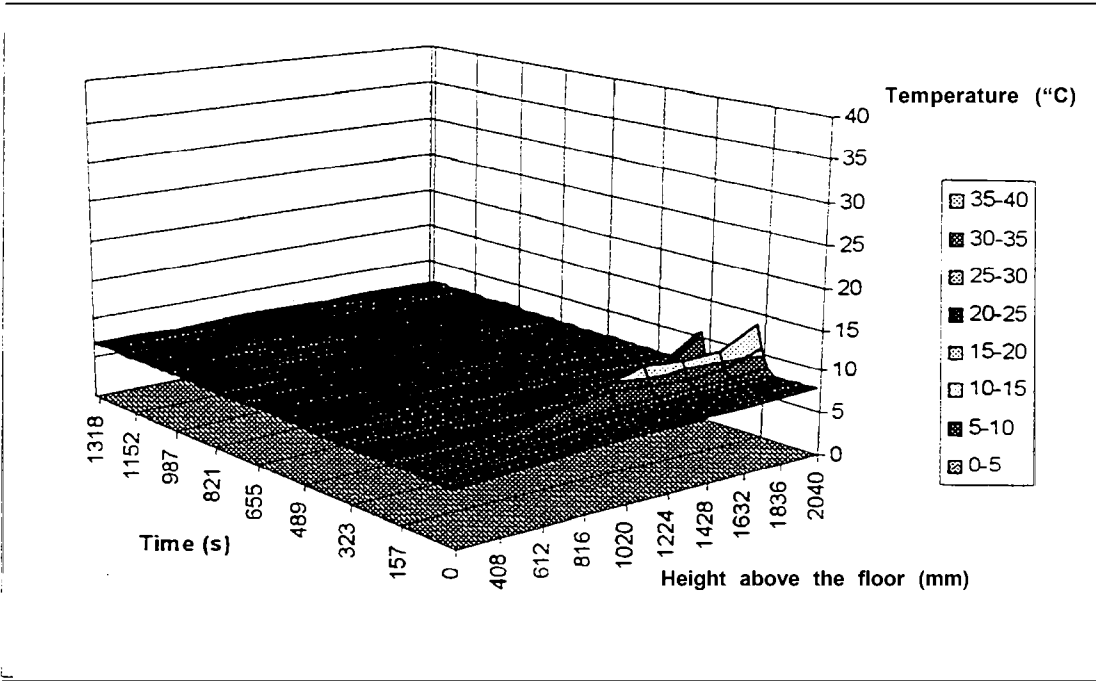

Figure FO5-15: Temperature distribution along the center line of Level 1 stairwell door

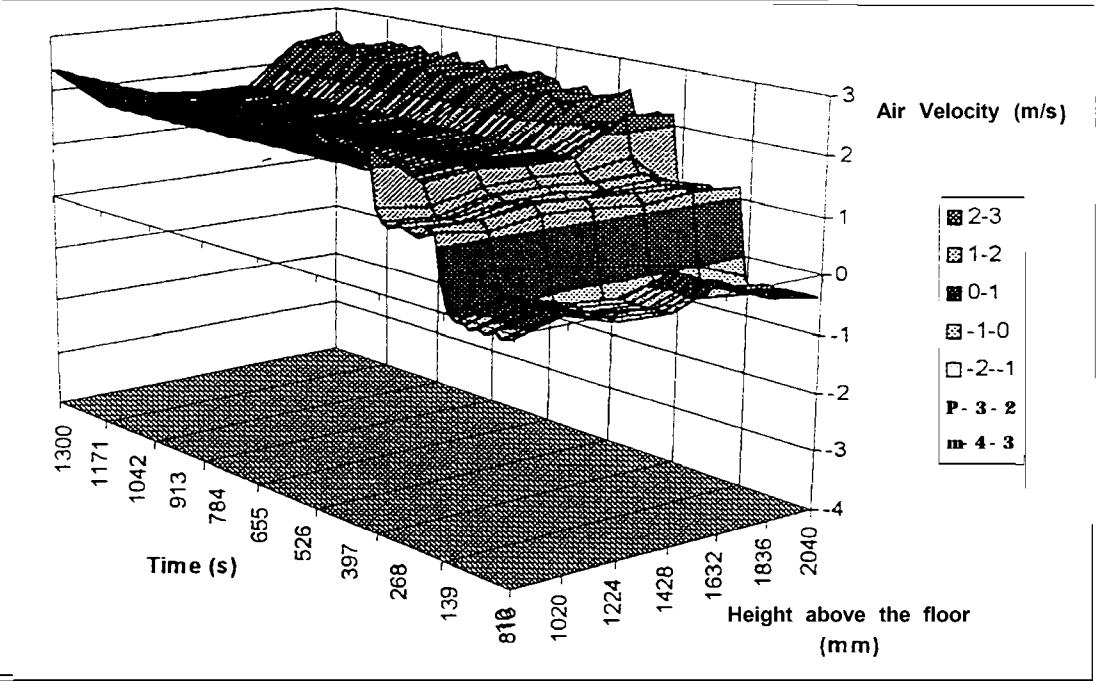

Figure FO5-16: Flow velocity distribution at the center line of Level 1 stairwell door

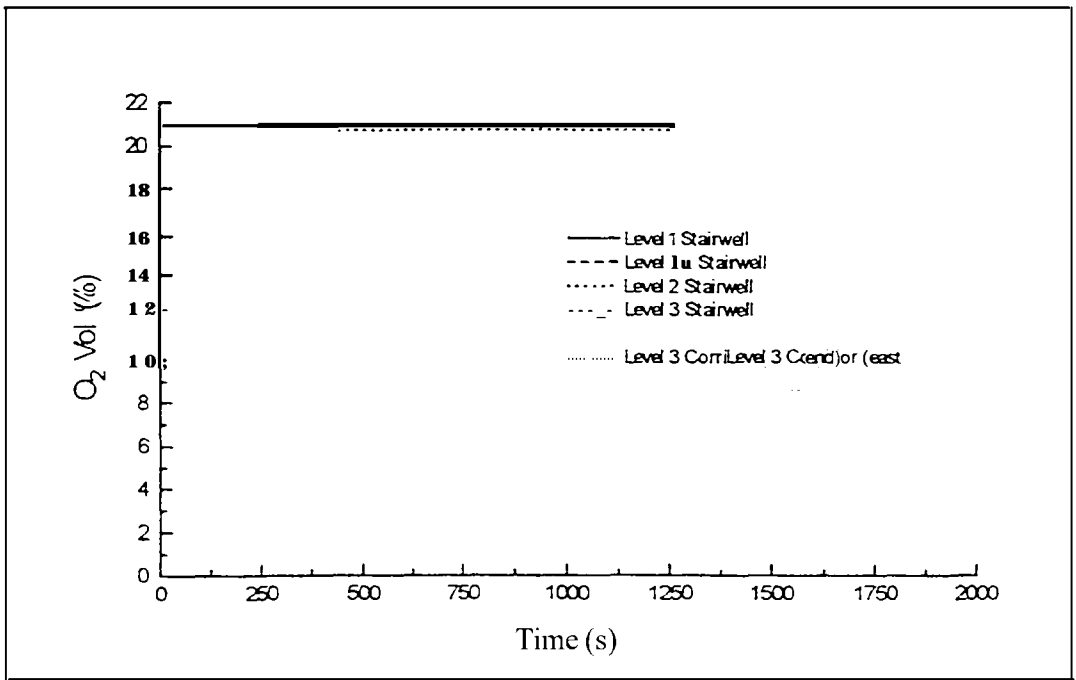

Figure FO5-17: Oxygen concentration at the stairwell doors (1.7 m above the floor)

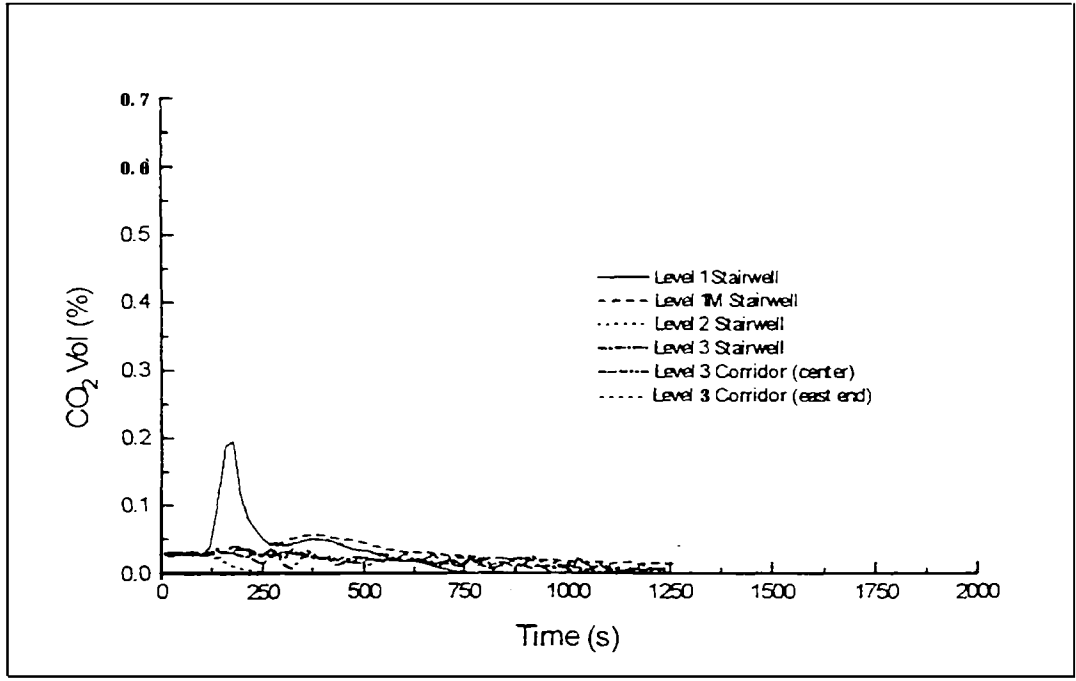

Figure FO5-18: Carbon dioxide concentration at the stairwell doors (1.7 m above the floor)

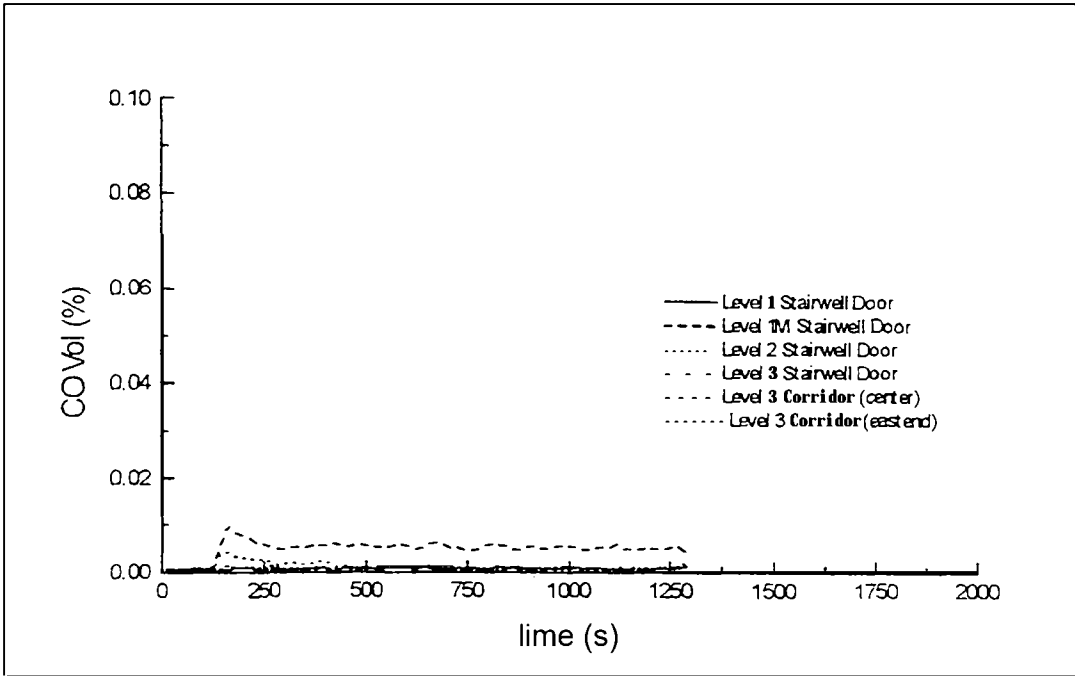

Figure FO5-19: Carbon monoxide concentration at the stairwell doors (1.7 m above the floor)

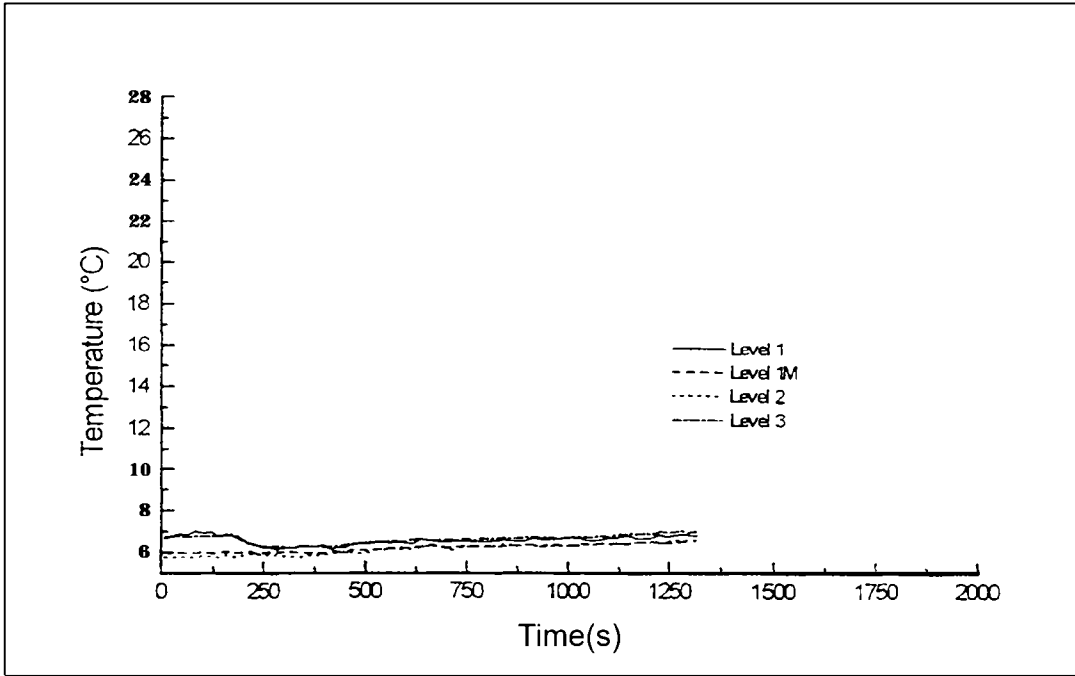

Figure FO5-20: Temperature in the stairwell at each level -North side (1.7 m above the floor)



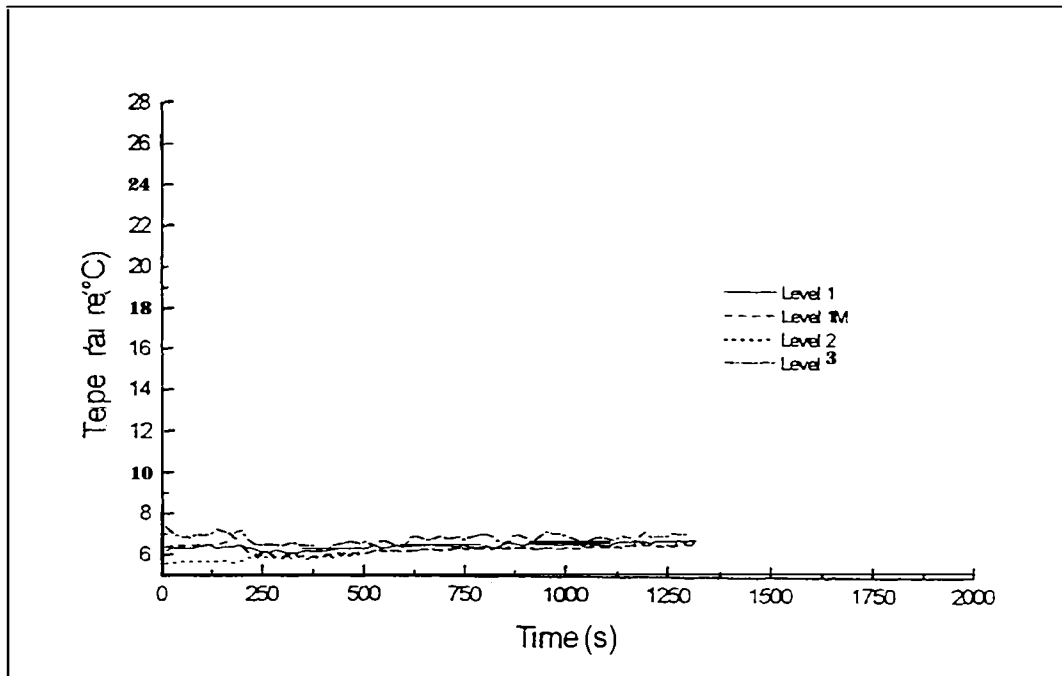

Figure F05-21: Temperature in the stairwell at each level-South side (1.7 m above the floor)

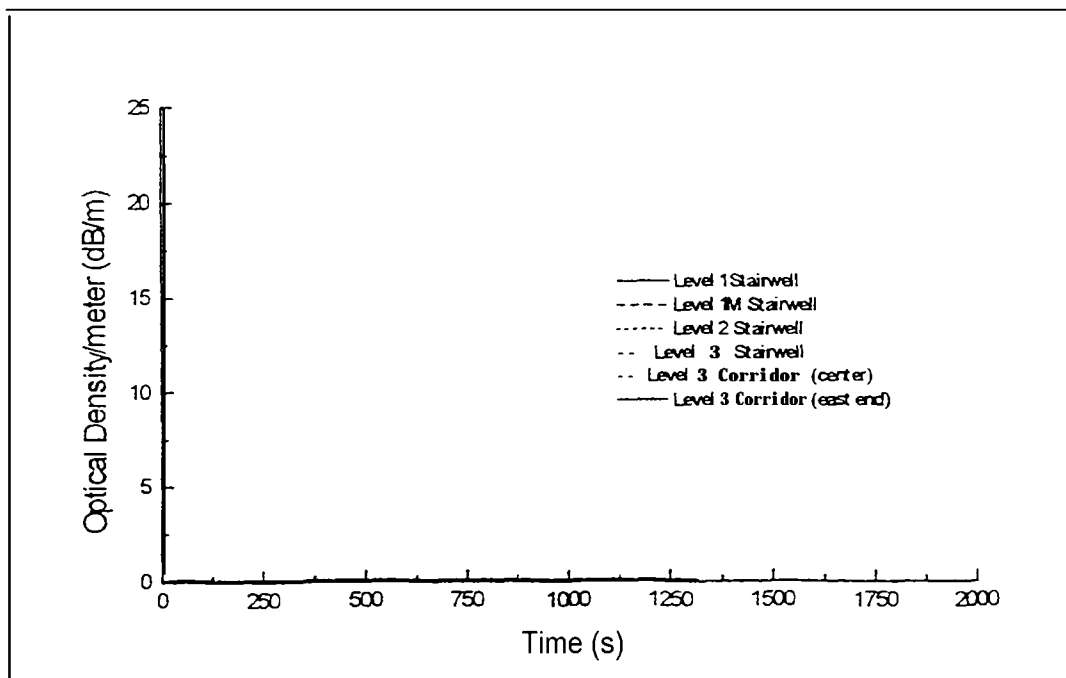

Figure F05-22: Optical density/m at six locations (1.7 m above the floor)

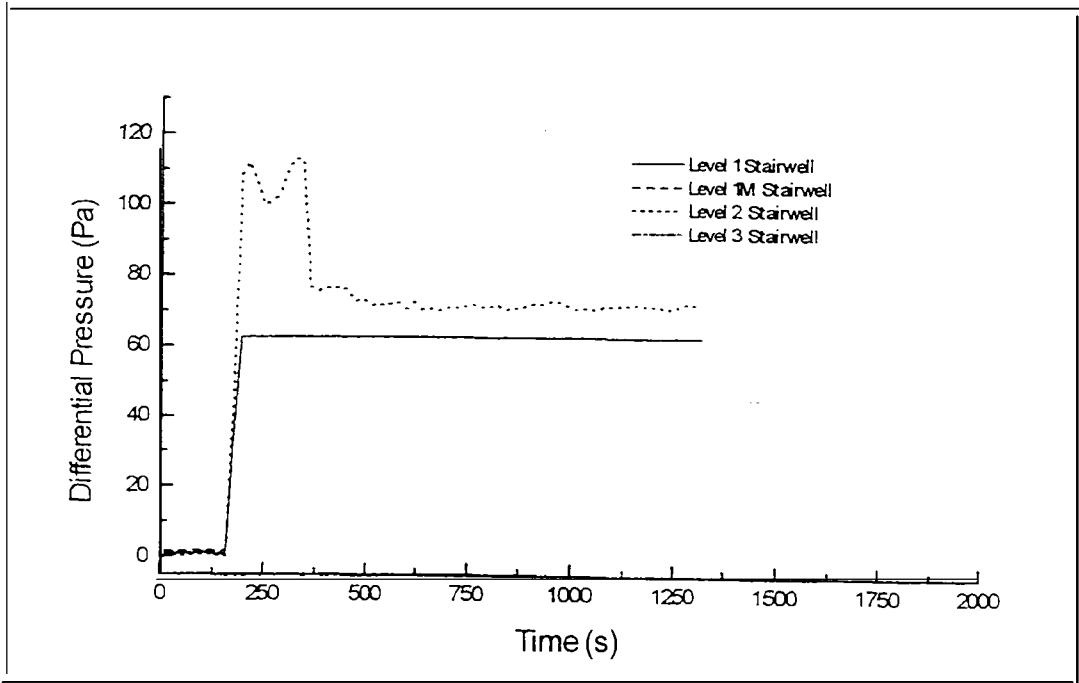

Figure FO5-23: Pressure differences between outside and the stairwell at each level (1.7 m above the floor)

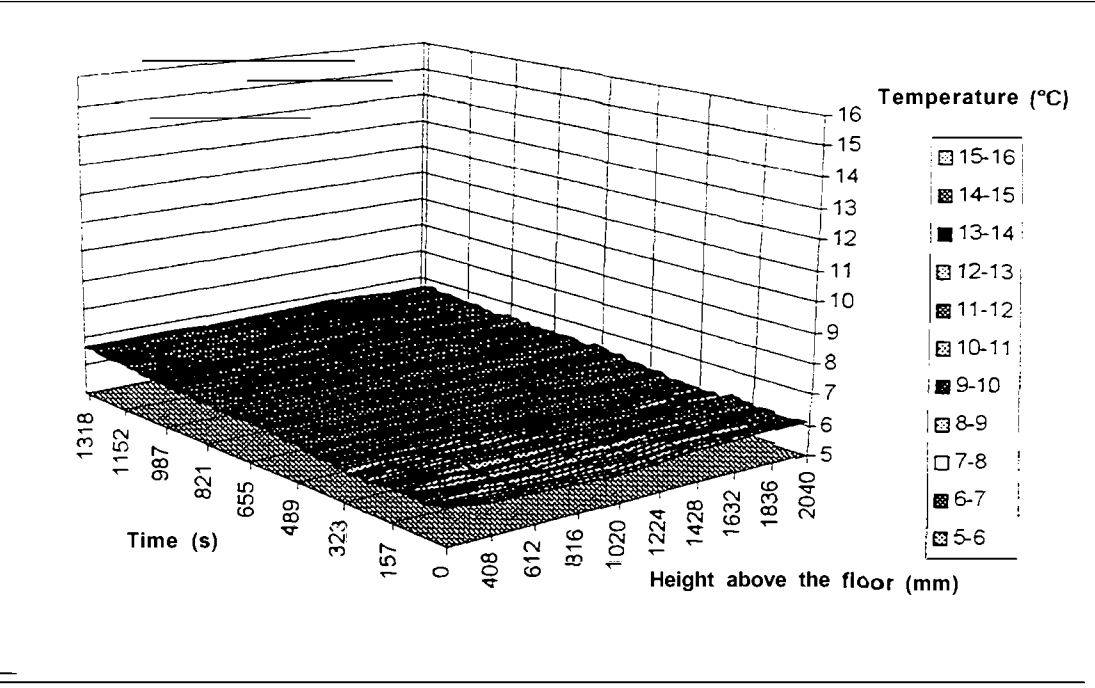

Figure FO5-24: Temperature distribution along the center line of Level 1M stairwell door

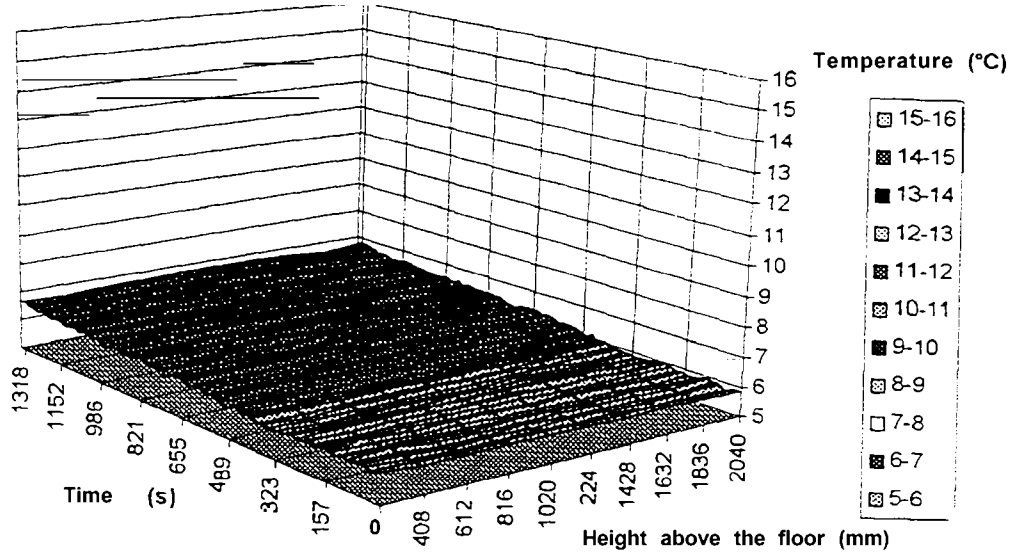

Figure FO5-25: Temperature distribution along the center line of Level 2 stairwell door

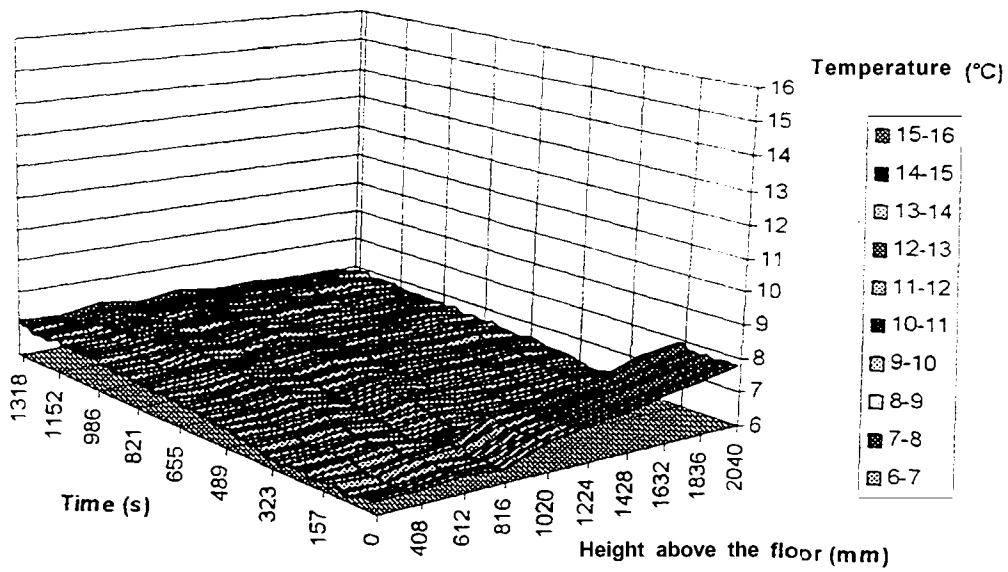

Figure FO5-26: Temperature distribution along the center line of Level 3 stairwell door

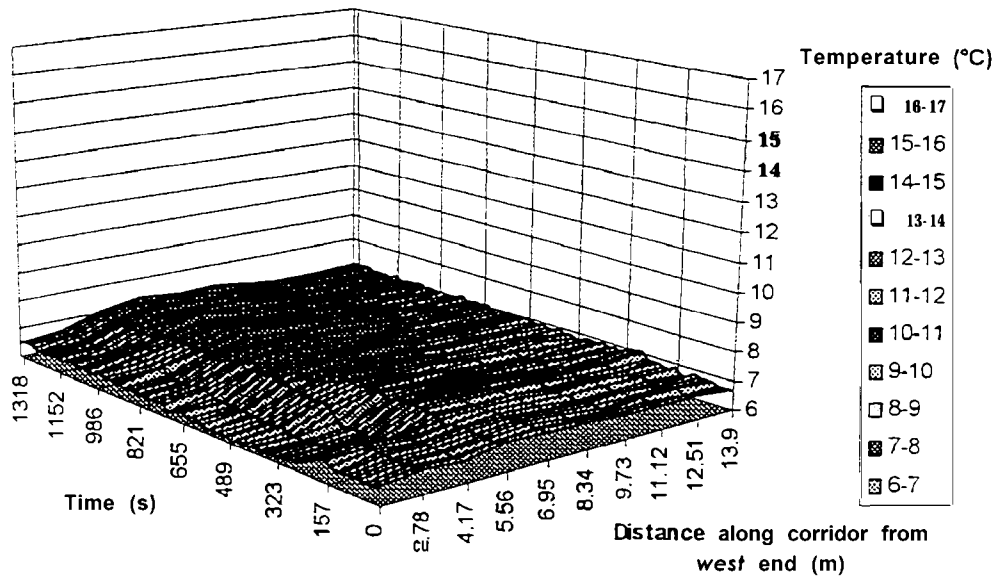

Figure FO5-27: Temperature distribution along Level 1M corridor (1.7 m above the floor)

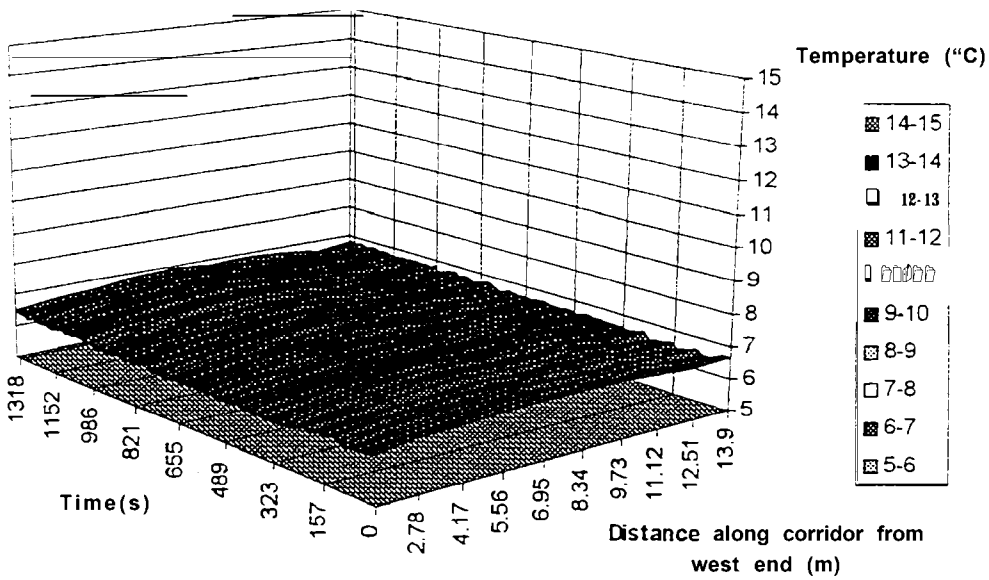

Figure FO5-28: Temperature distribution along Level 2 corridor (1.7 m above the floor)

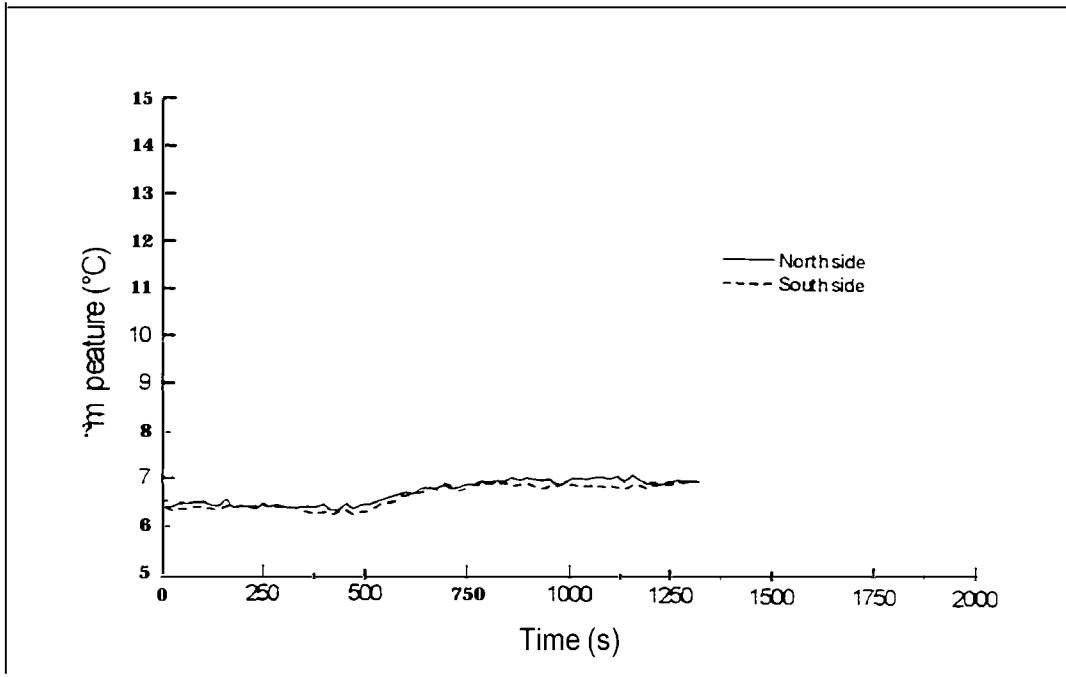

Figure FO5-29: Temperatures in Room 201 (1.7 m high)

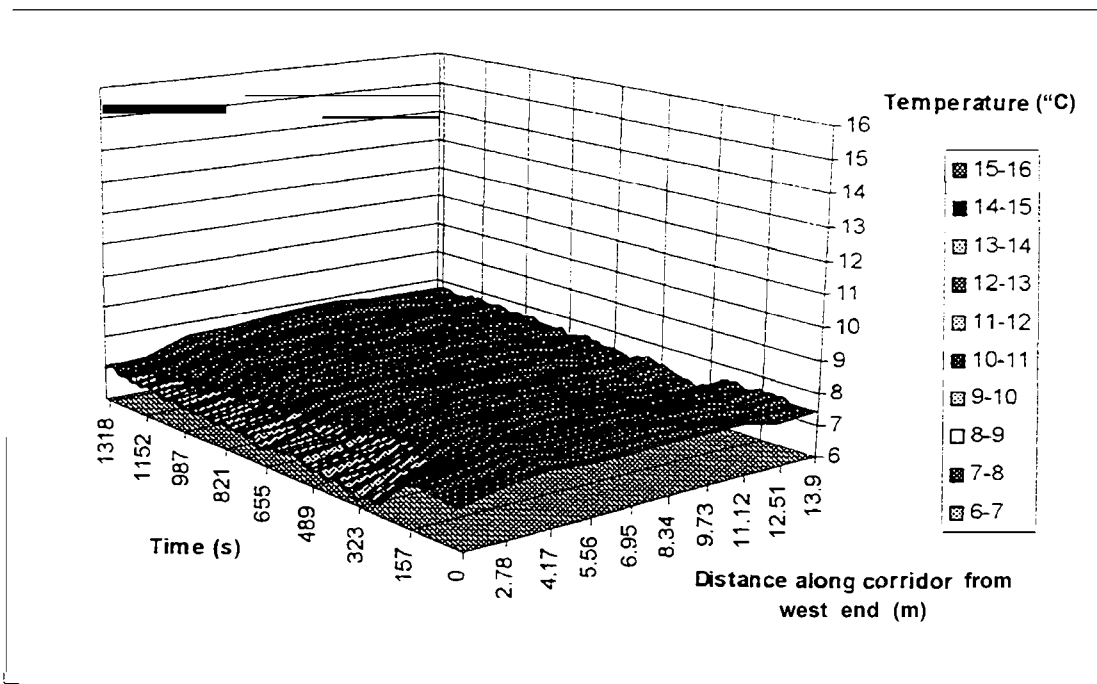

Figure FO5-30: Temperature distribution along Level 3 corridor (1.7 m above the floor)

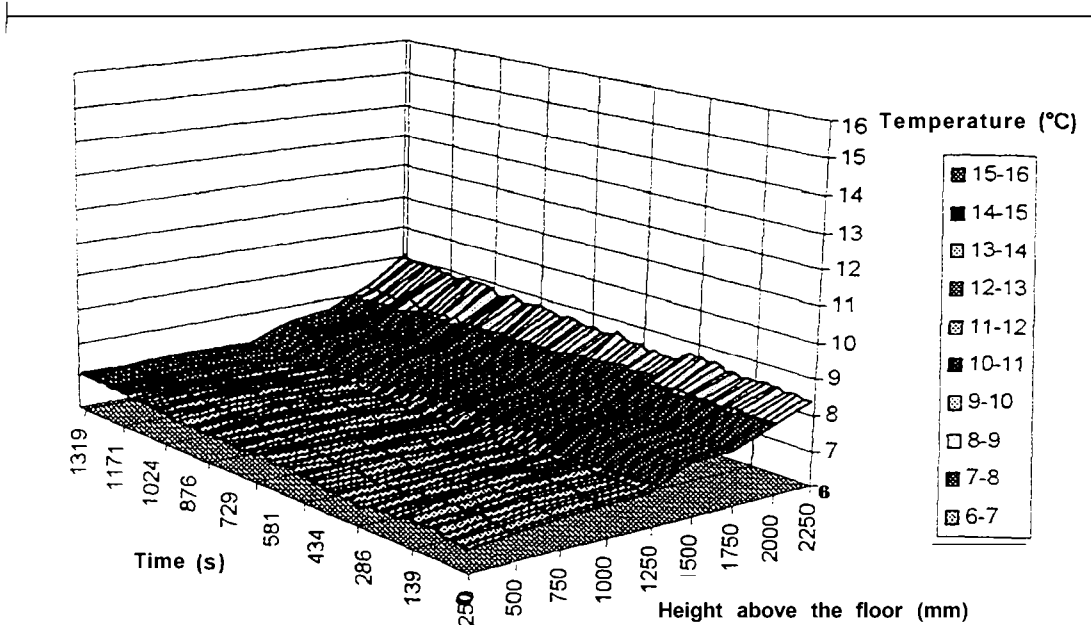

Figure FO5-31: Vertical temperature distribution in the center of Level 3 corridor

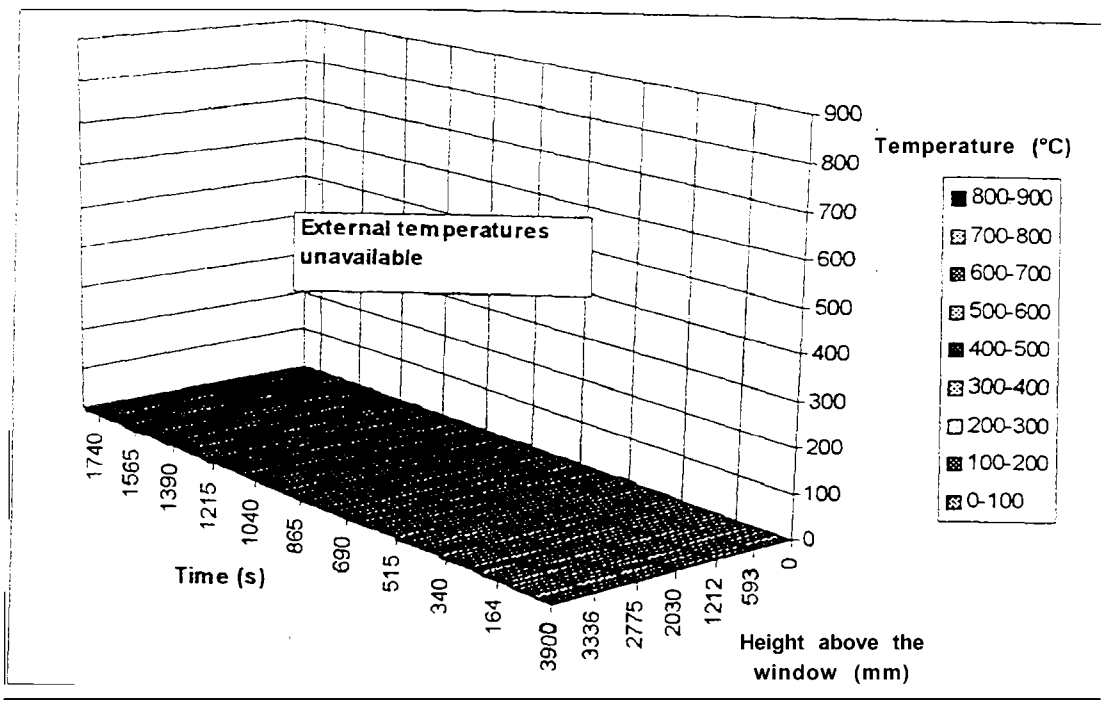

Figure FO5-32: External temperature along the center line of the bum room window (0.02 m from the wall)

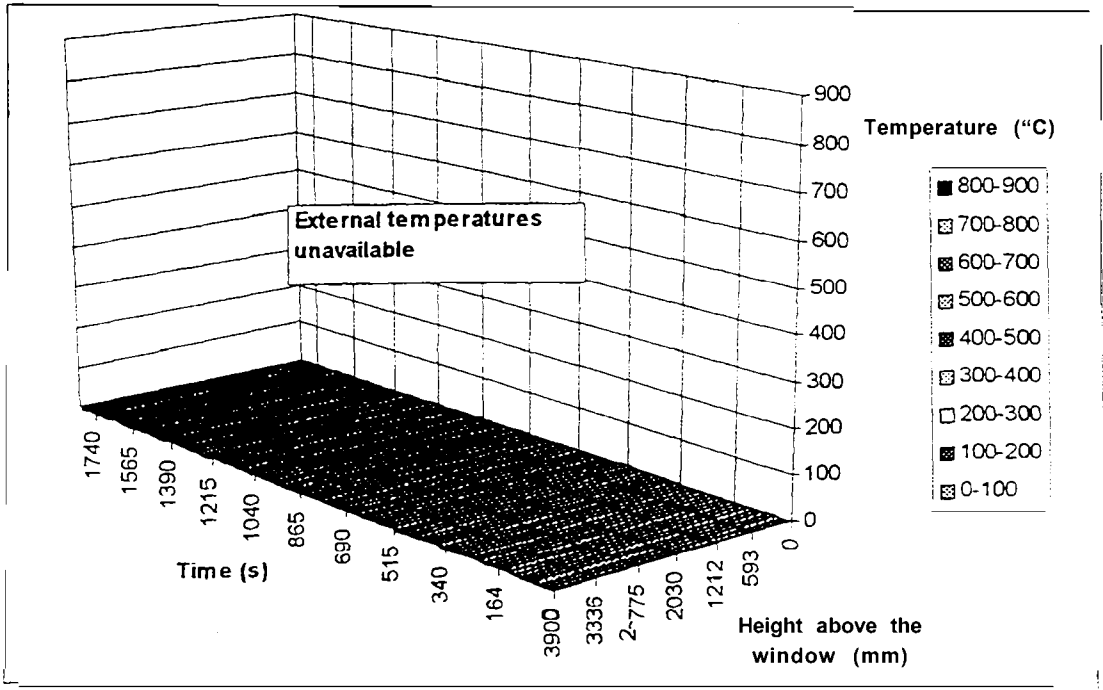

Figure FO5-33: External temperature along the center line of the bum room window (0.5 m from the wall)

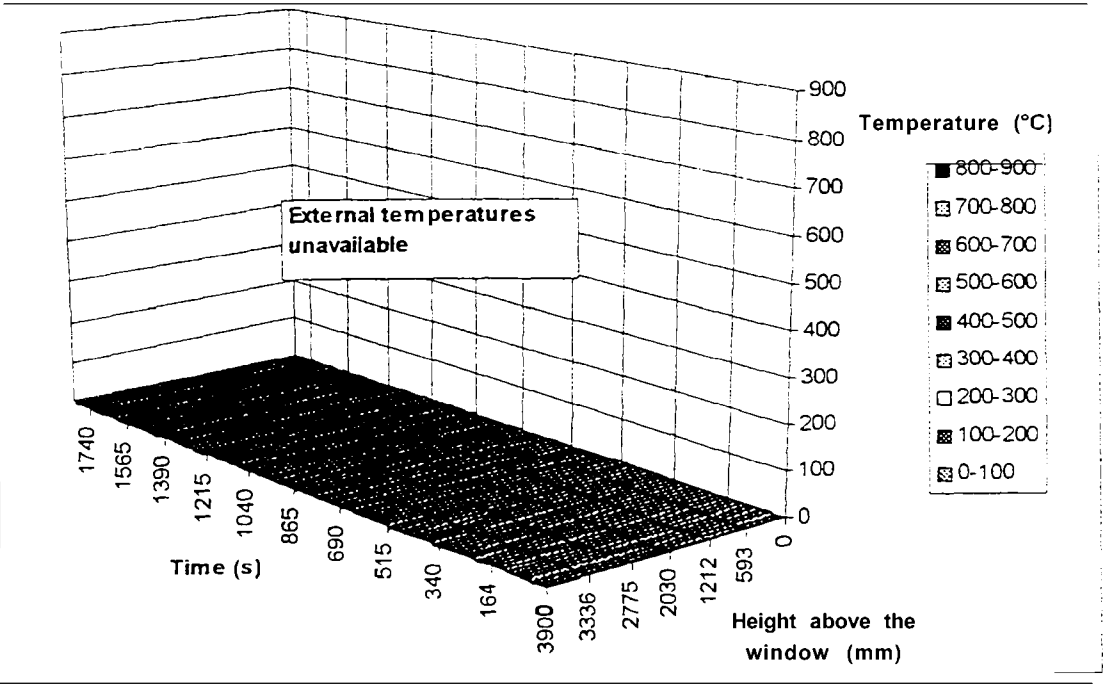

Figure FO5-34: External temperature along the center line of the bum room window (1.0 m from the wall)

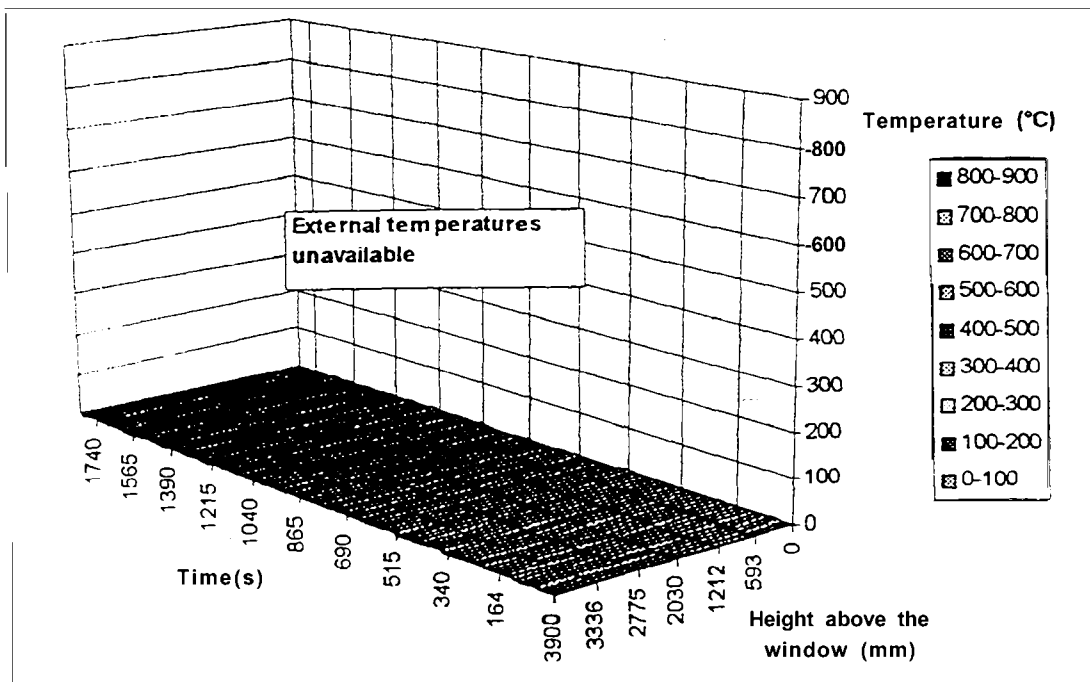

Figure FO5-3 5: External temperature along the center line of the bum room window ( 1.5 m from the wall)

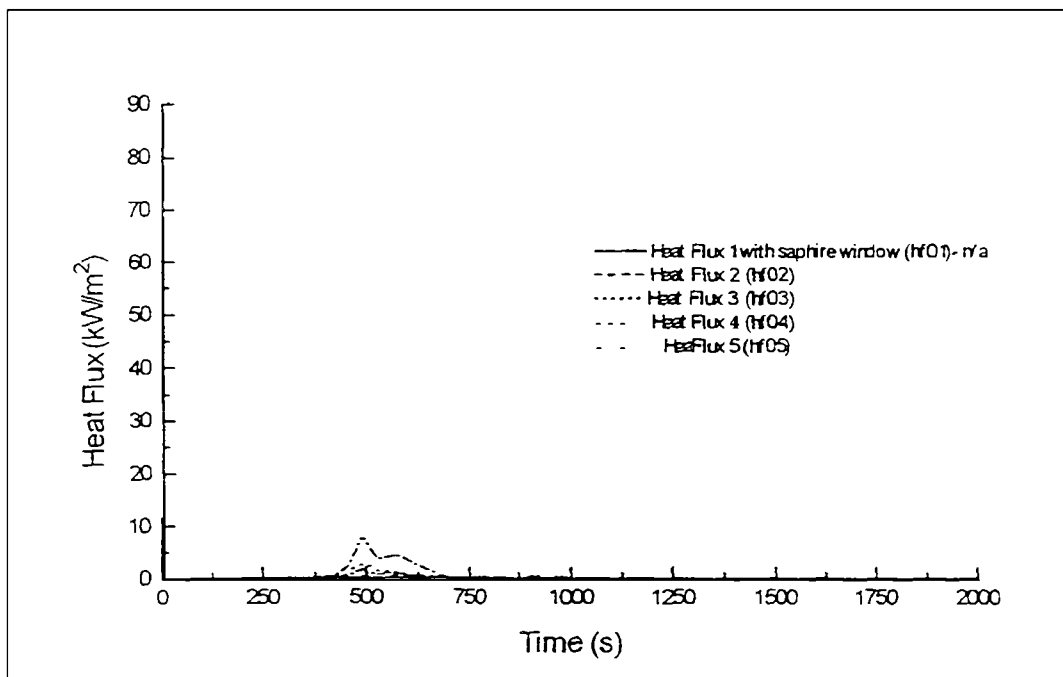

Figure FO5-36: External heat flux measurements (Refer to Figure 25 for locations)



## 14. Flashover Test FO6

**Test Conditions:**     **Bum Room Door Closed**  
                          **Level 1 Stairwell Door Closed**  
                          **Smoke Management and Stair Pressurisation ON**

### Observations:

0:00 Ignition  
0:55 Ionisation detector (no cap) activated  
2:23 Photo-optical detector in return air duct activated  
      Smoke management and stair pressurisation systems activated  
3:20 Smoke filling the room (thin)  
3:30 Significant bowing of the window  
3:45 Initial cracking across the middle pane  
4:10 Sprinkler above the small platform activated (detection only)  
4:20 Room full of thick smoke  
4:30 More cracking of bum room window  
      Sprinkler above the large platform activated (detection only)  
4:55 Window lowered  
5:55 Flames 0.6 m high above the window opening  
6:19 Flashover occurs  
      Flames 1.2 m high above the window opening  
6:35 Initial cracking of 1M window  
8:20 Initial dislodgment of 1M window  
10:00 Flames 2.0 m high above the window opening  
11:00 More cracking and dislodgment of 1 M window  
12:00 More dislodgment of 1M window  
12:40 Remaining glass in 1M dislodged  
17:00 Very little smoke coming out of the bum room window and the bum room door  
      clearly visible through window opening

Despite the smoke management system activating this test progressed to flashover and was quite severe. The sprinkler in Level 1 corridor did not activate and the P/U and the carpet in Level 1 corridor were unaffected by the fire.

**Table 12: Summary of results for Test F06**

<b>In the Burn Room</b>	
Maximum Heat Release Rate	8.1 MW
Maximum Peak Temperature	1071 °C
Maximum Average Room Temperature	983°C
Minimum Oxygen Concentration	1.2 Vol %
Maximum Total Heat Flux	109 kW/m <sup>2</sup>
Time untenability reached (1 00°C)	245 s

<b>At the Burn Room Door</b>		
Maximum CO Concentration a		na Vol %
Maximum CO <sub>2</sub> Concentration		na Vol %
Maximum Temperature		45 °C
Minimum Oxygen Concentration		na Vol %
<b>In Level 1 Corridor</b>		
Maximum Temperature 1.5 m above the floor		14 °C
Maximum Temperature in the center of the Corridor		<b>20 °C</b>
<b>Stairwell</b>		
Maximum Temperature	Level 1	<b>6 °C</b>
	Level 1M	<b>6 °C</b>
	Level 2	<b>6 °C</b>
	Level 3	<b>7 °C</b>
<b>Level 3 Corridor</b>		
Maximum Temperature		8 °C
<b>External</b>		
Maximum External Temperature		710 °C
Maximum Total Heat Flux		55 kW/m <sup>2</sup>

Note: A full list of detector and sprinkler activation times is shown in Table 15 & 16. Only the time for the first detector activated is listed in the above observations.

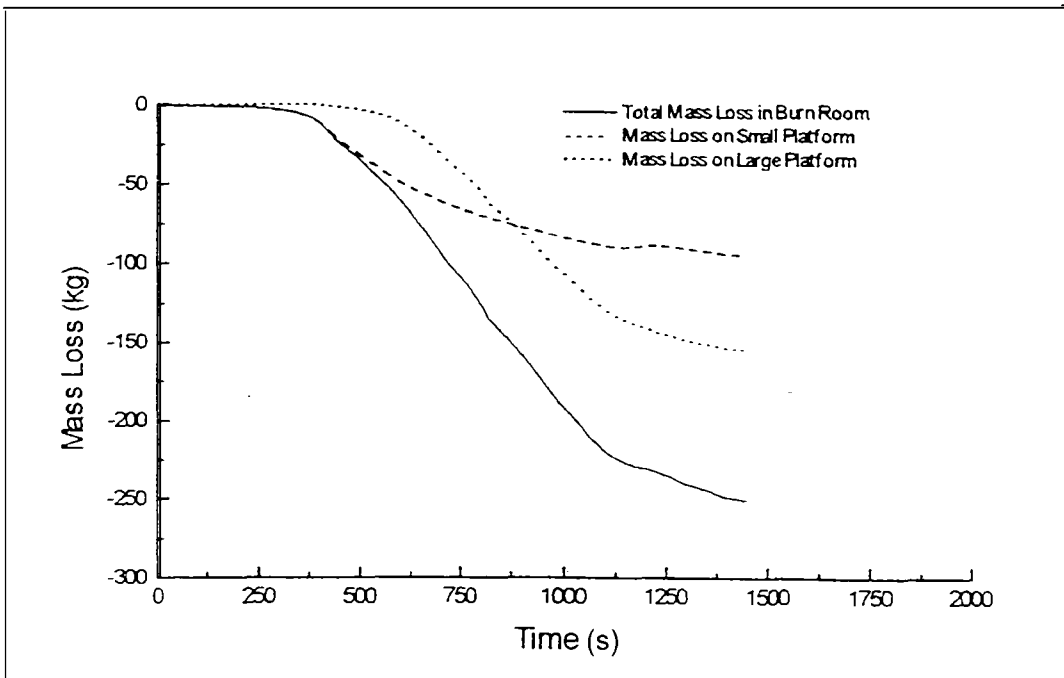

Figure FO6- 1: Combined mass loss in the bum room

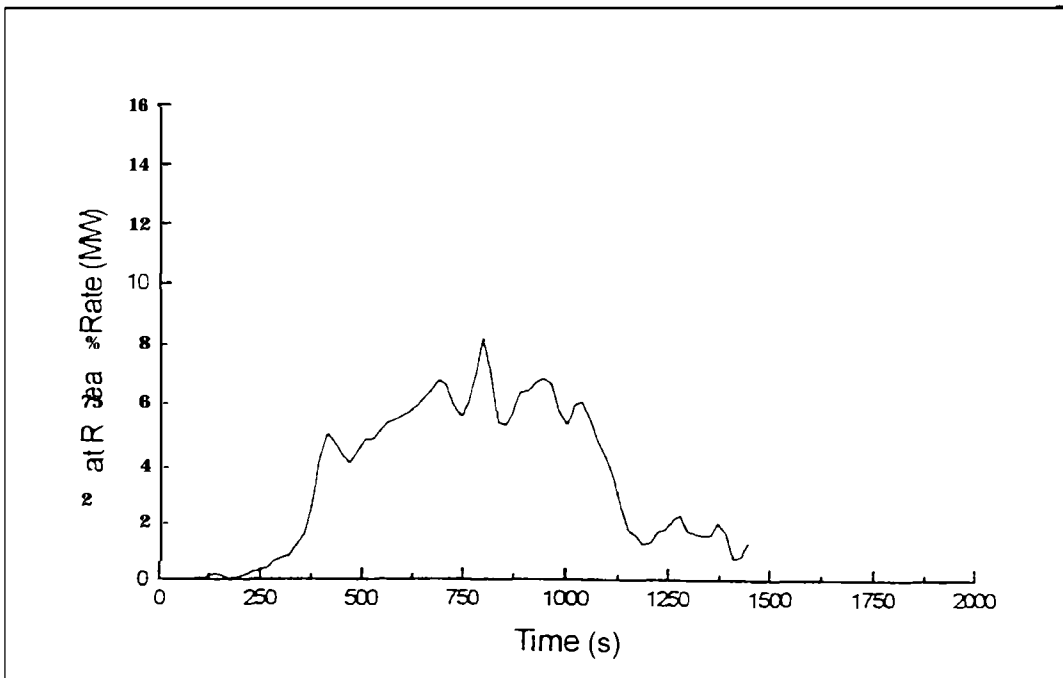

Figure FO6-2: Total heat release rate in the bum room

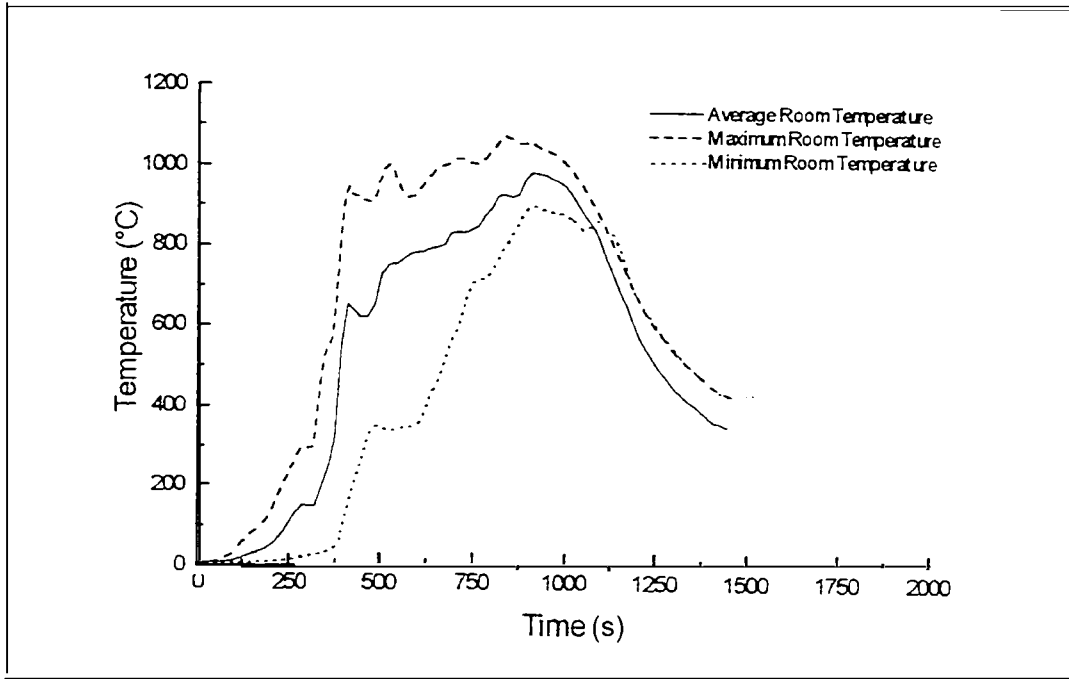

Figure FO6-3 : Average, maximum and minimum temperatures in the bum room

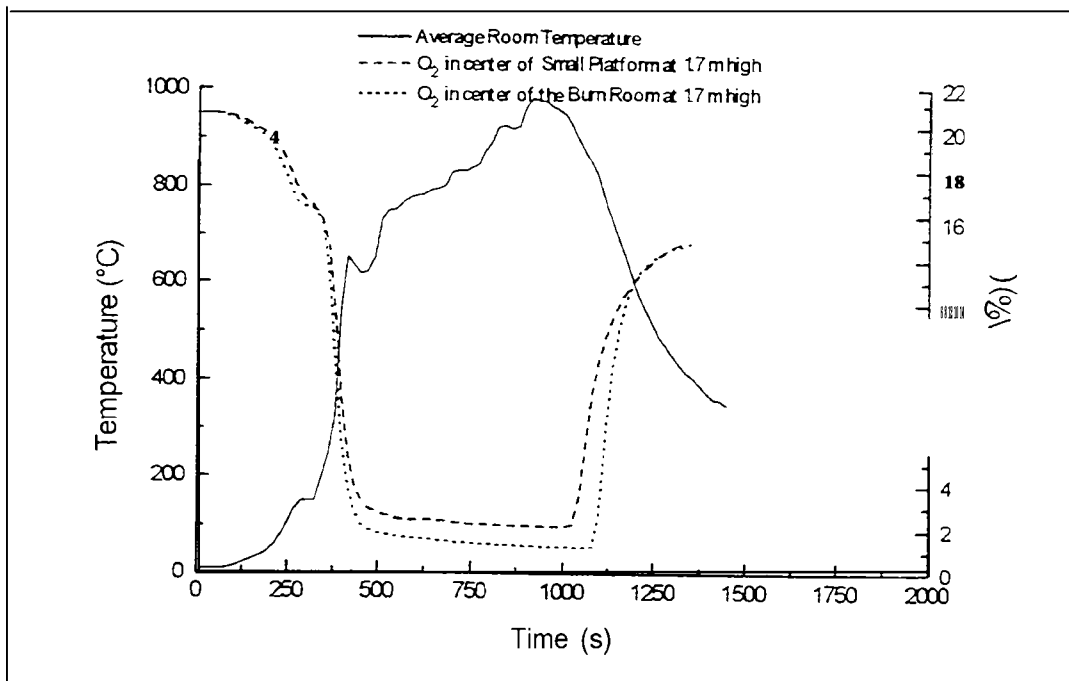

Figure FO6-4: Oxygen concentration and average temperature in the bum room

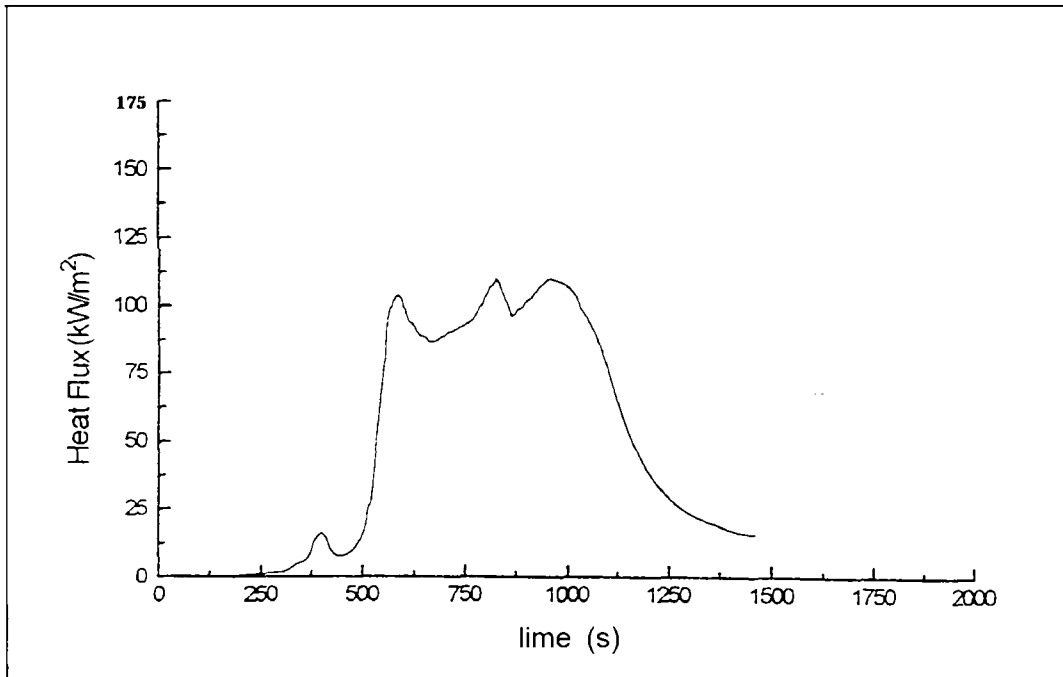

Figure FO6-5: Total heat flux in the center of the bum room

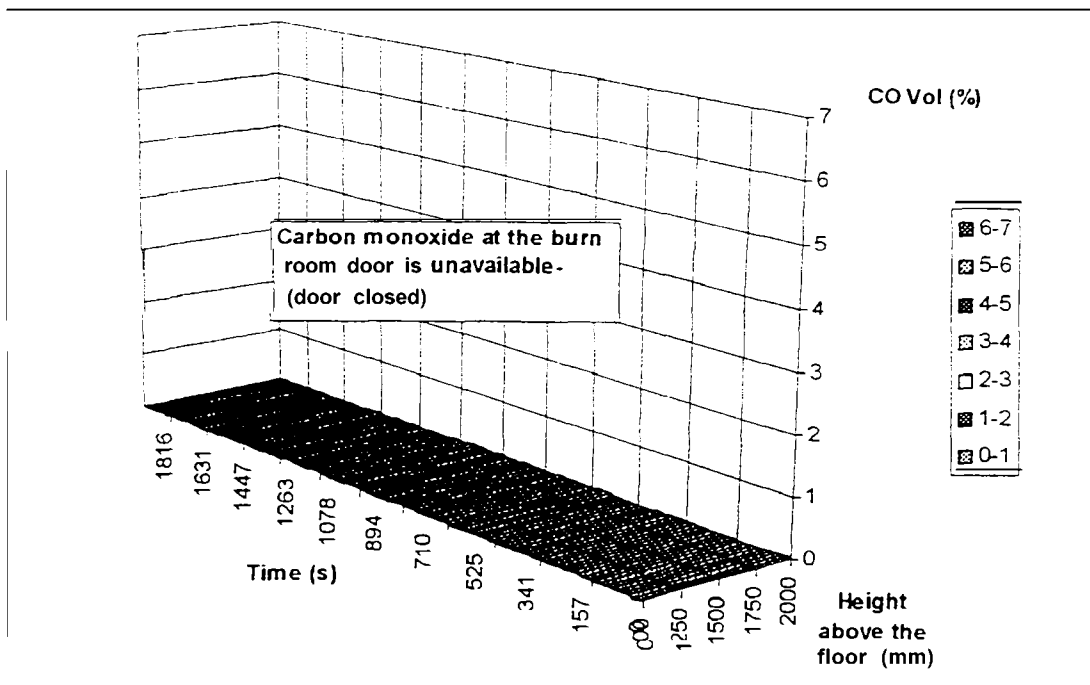

Figure FO6-6: Carbon monoxide concentration along the center line of the bum room door

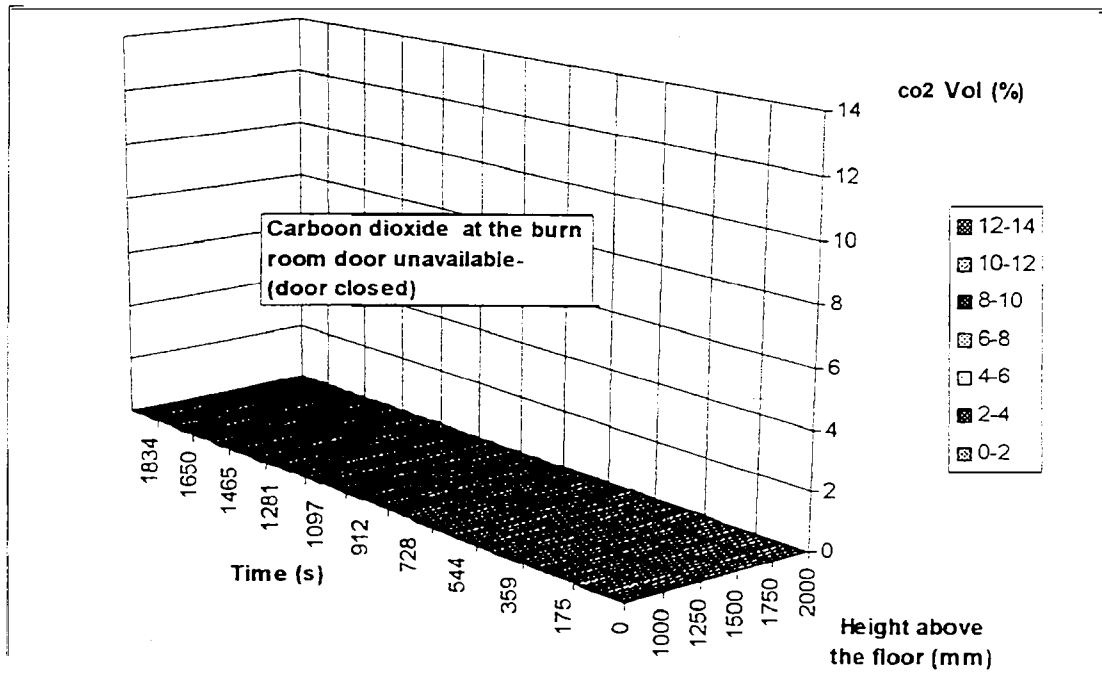

Figure FO6-7: Carbon dioxide concentrations along the center line of the burn room door

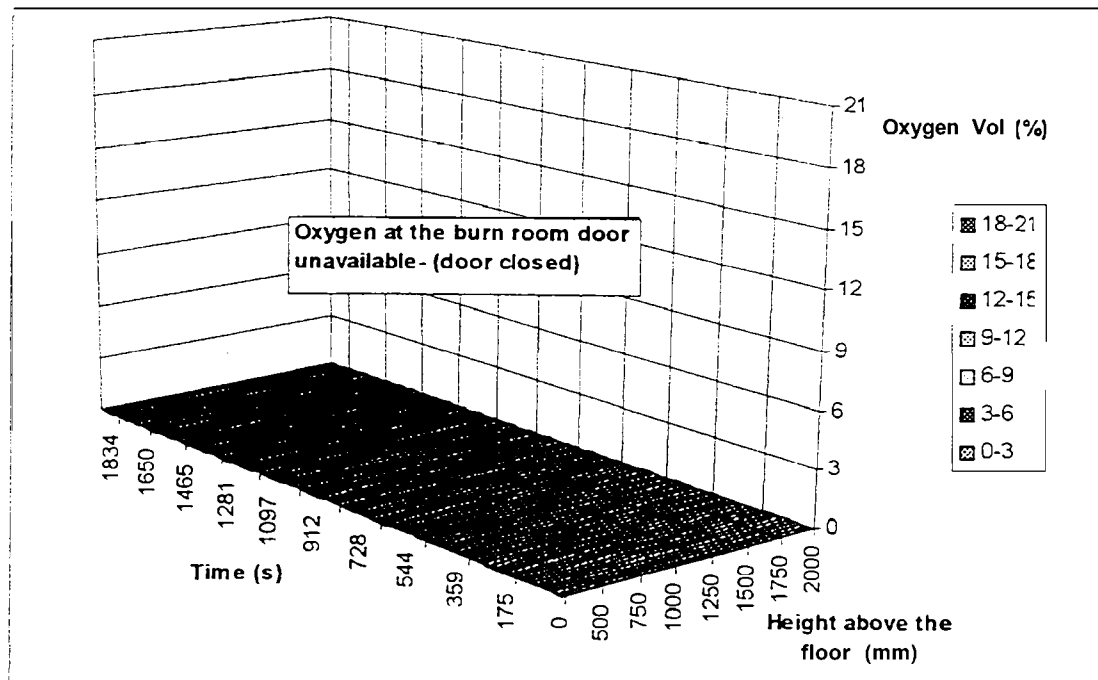

Figure FO6-8: Oxygen concentrations along the center line of the burn room door

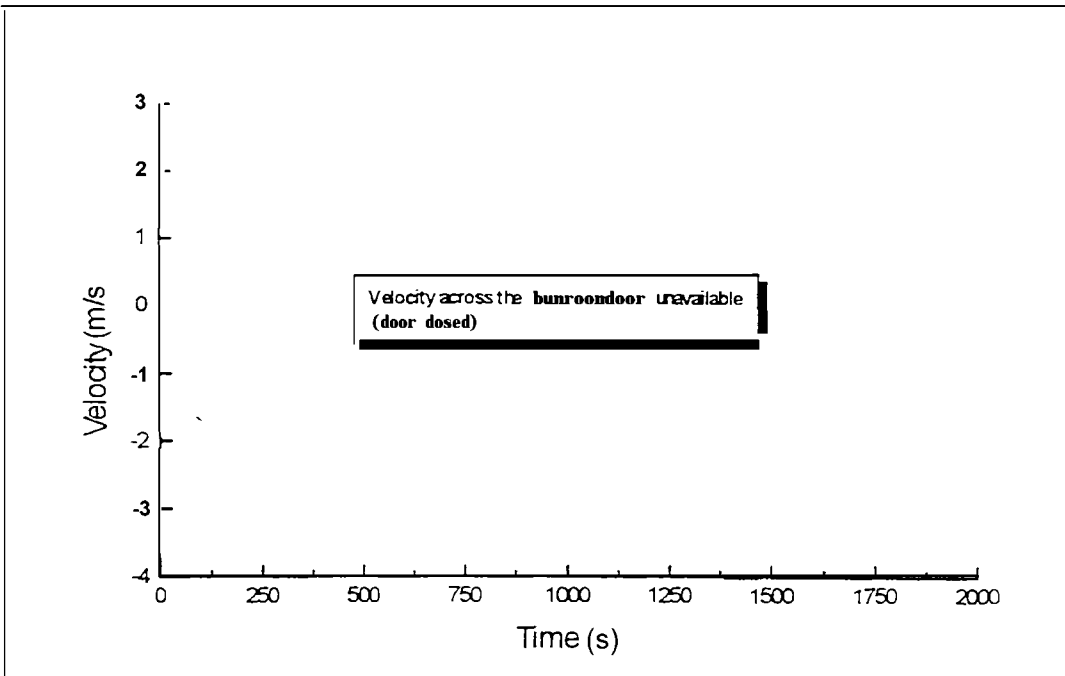

Figure FO6-9: Flow velocity distribution at the center line of the bum room door

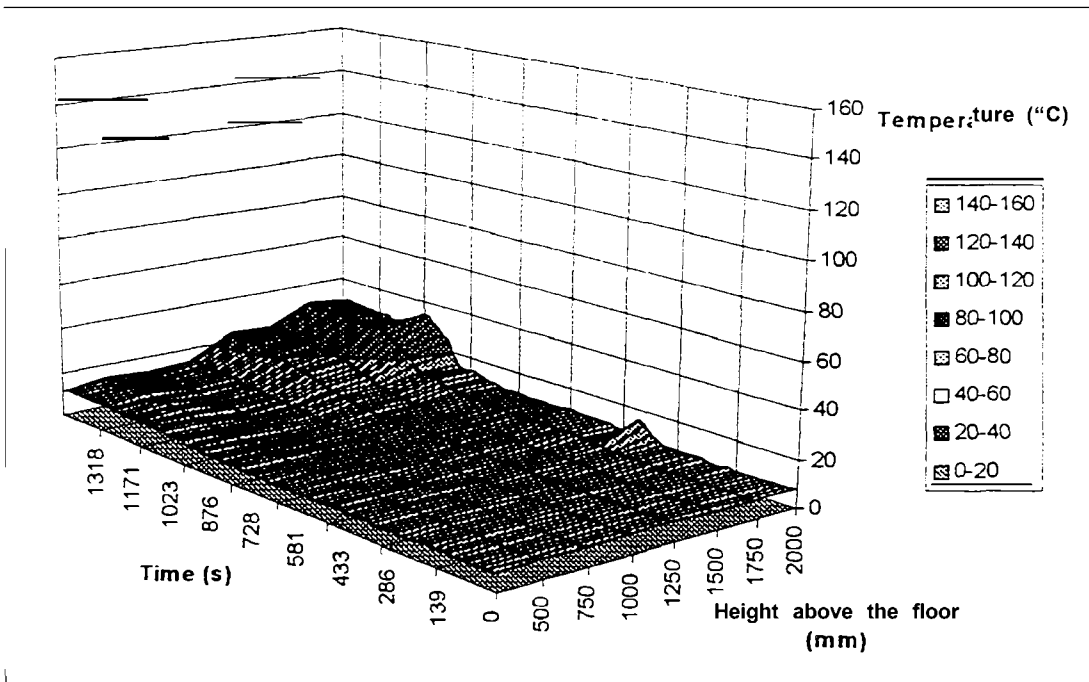

Figure FO6-10: Temperature distribution along the center line of the bum room door

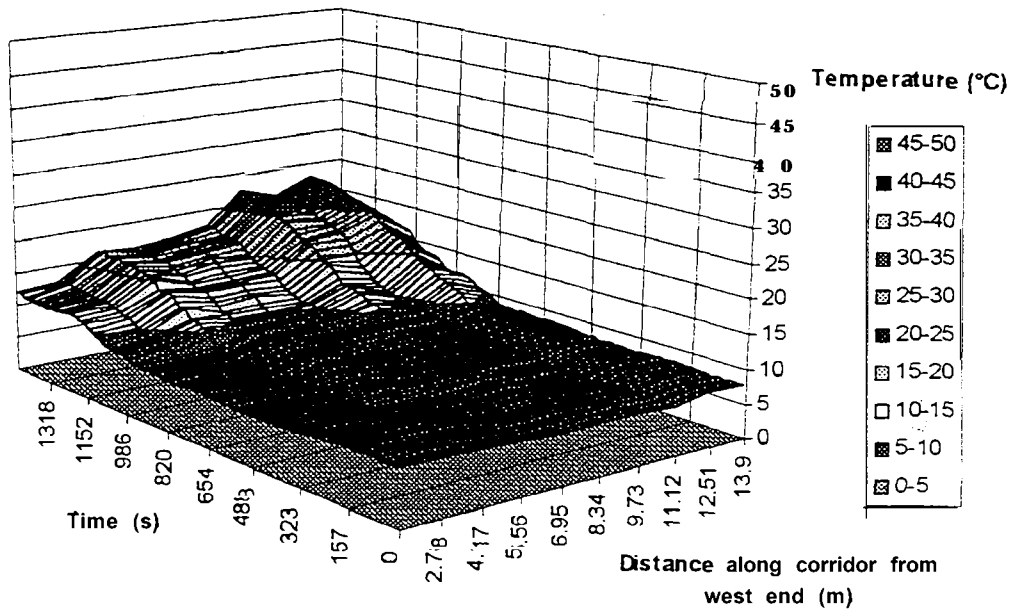

Figure FO6-11: Temperature along Level 1 corridor (2.0 m above the floor)

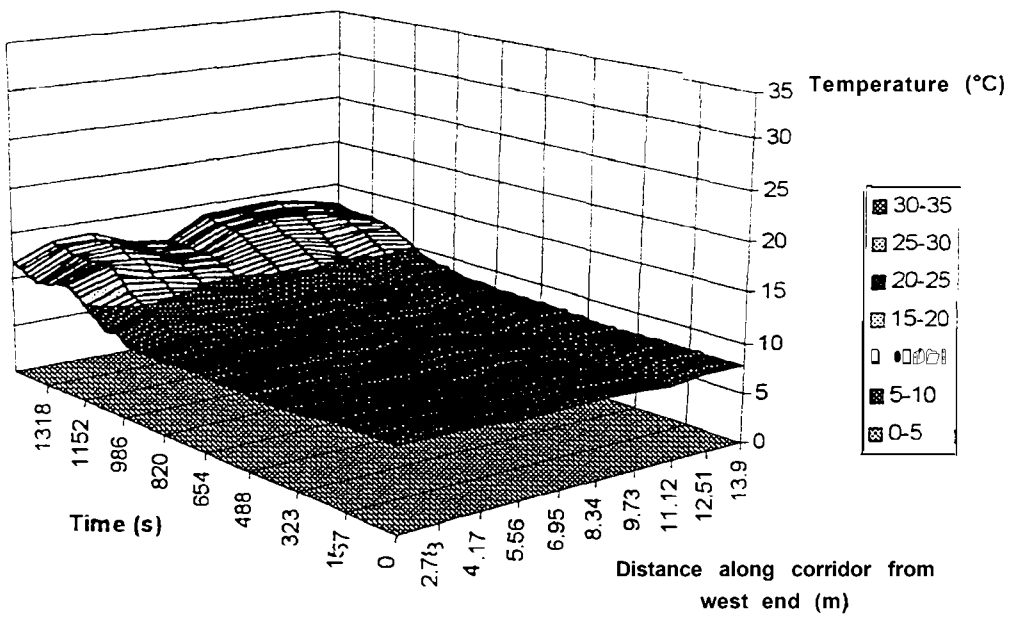

Figure FO6-12: Temperature along Level 1 corridor (1.5 m above the floor)



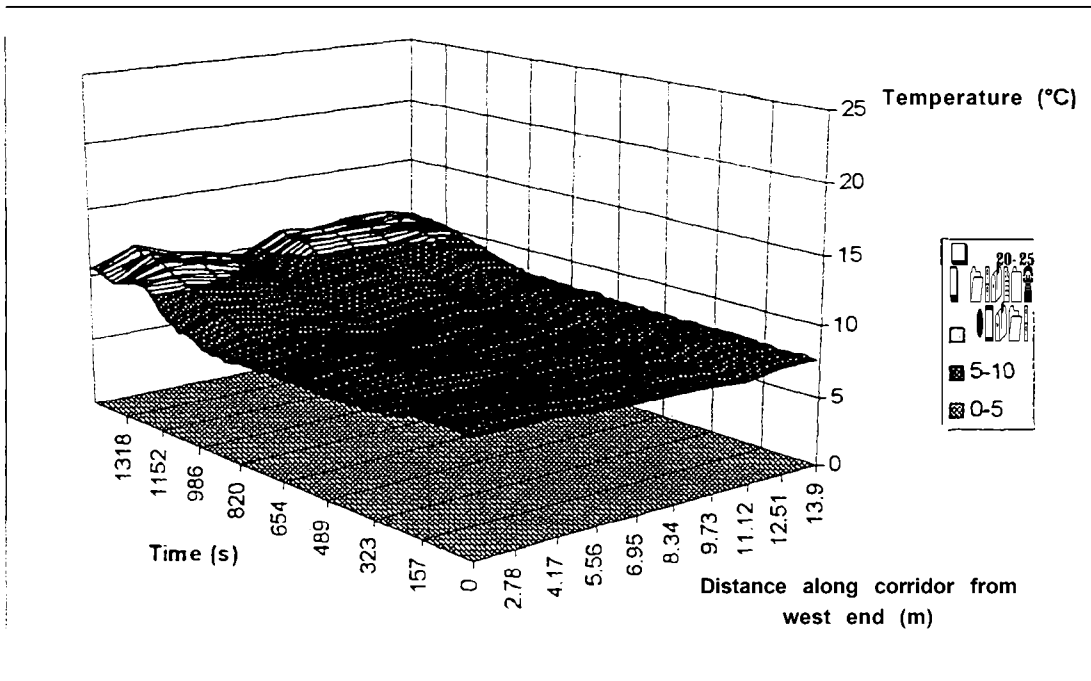

Figure FO6-13: Temperature along Level 1 corridor (0.5 m above the floor)

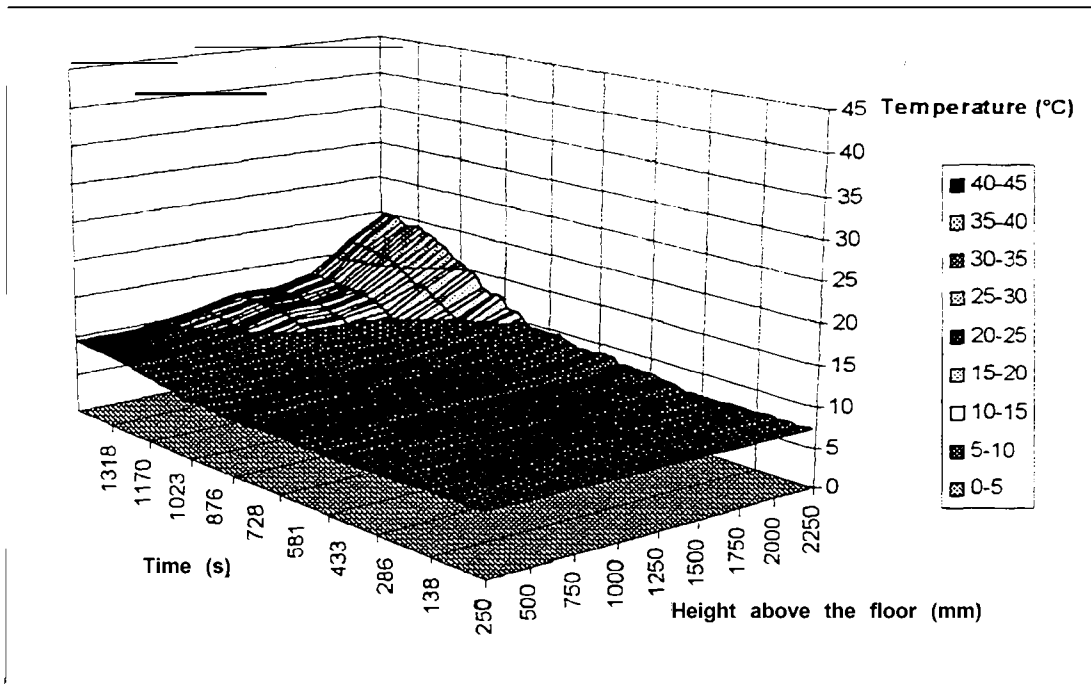

Figure FO6-14: Vertical temperature distribution in the center of Level 1 corridor

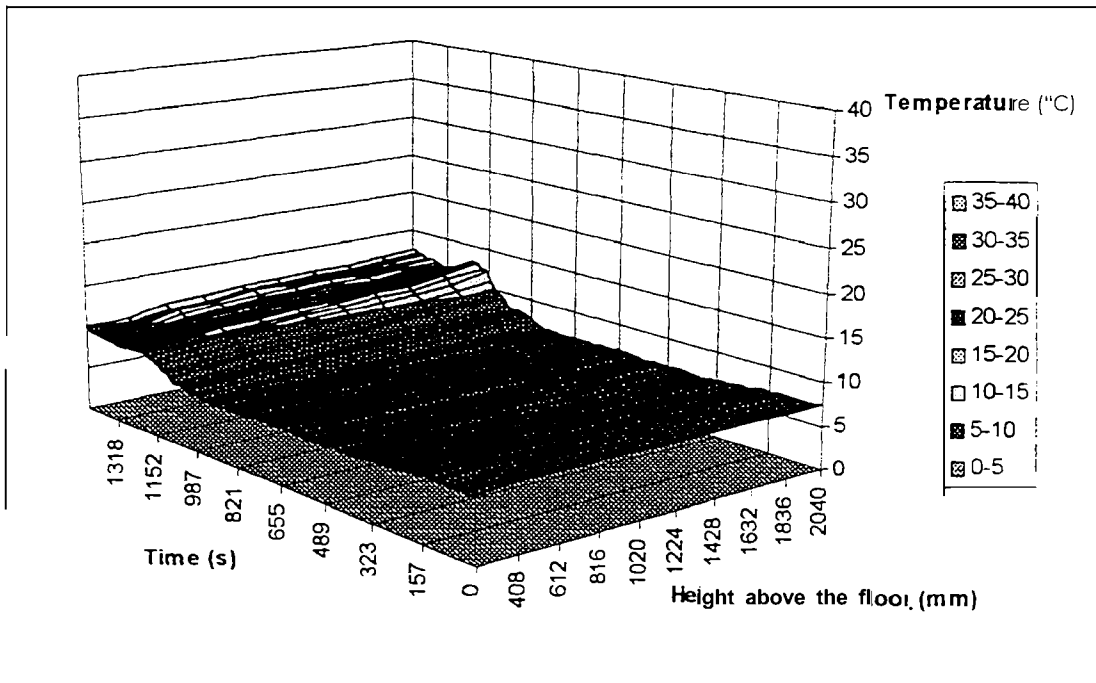

Figure FO6- 15 : Temperature distribution along the center line of Level 1 stairwell door

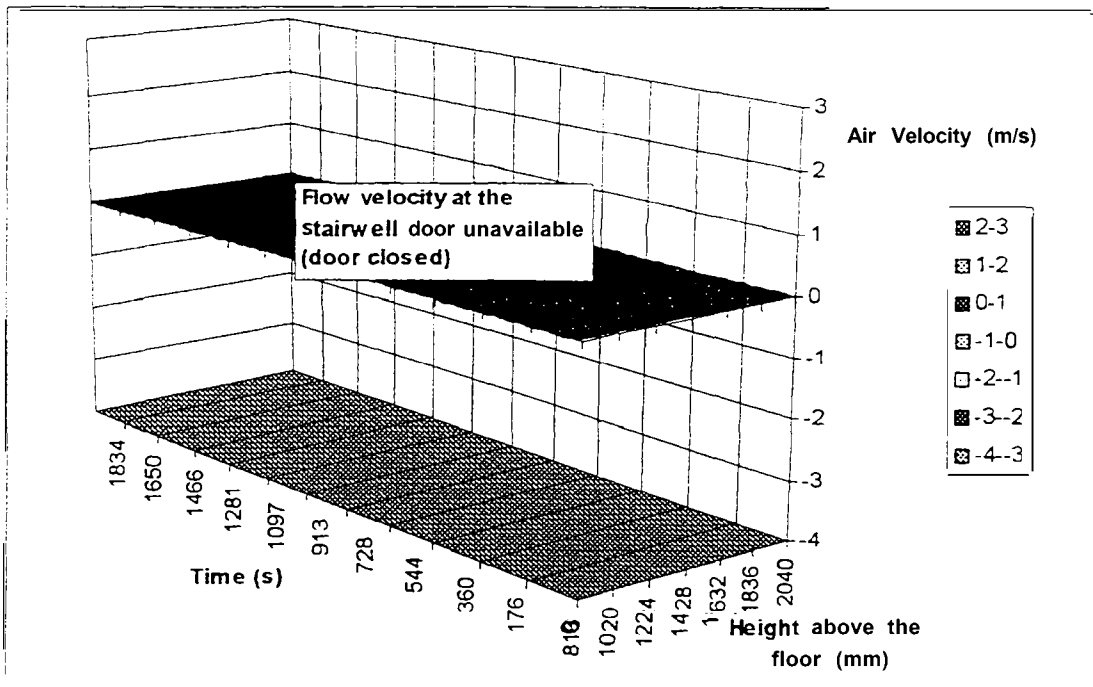

Figure FO6-16: Flow velocities measured along the center line of Level 1 stairwell door

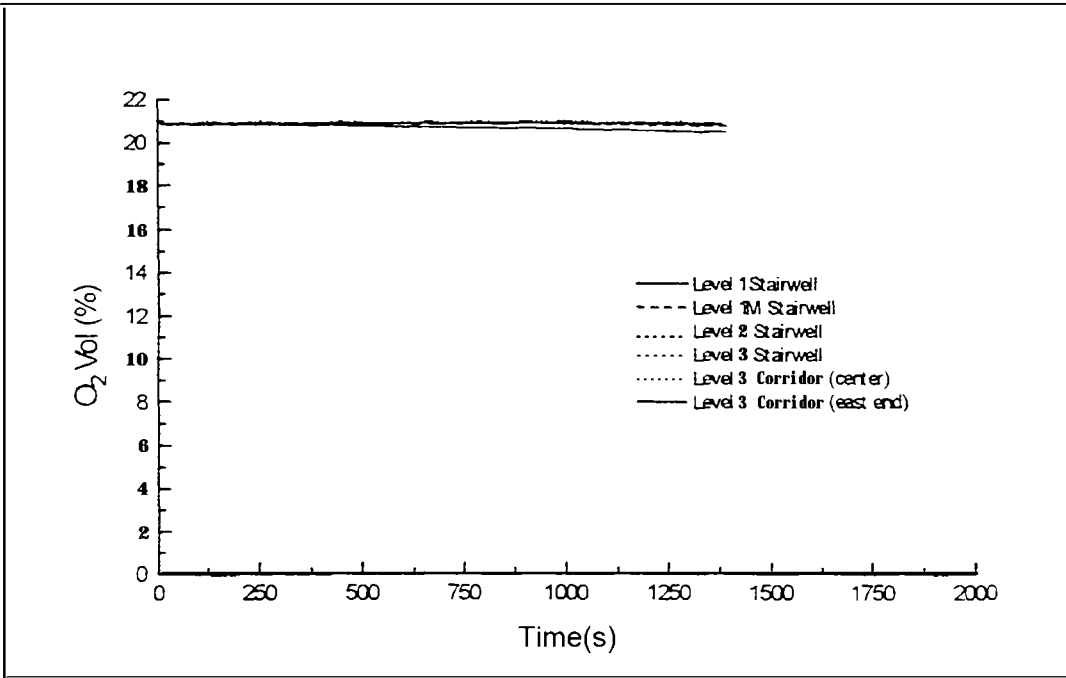

Figure FO6- 17: Oxygen concentration at the stairwell doors (1.7 m above the floor)

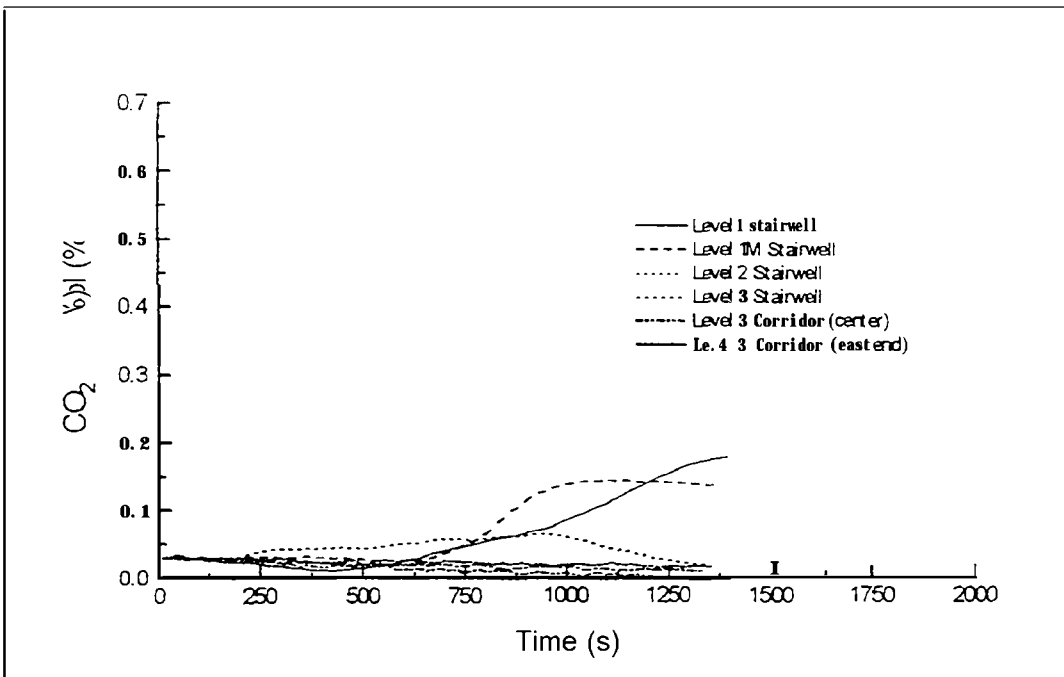

Figure FO6-18: Carbon dioxide concentration at the stairwell doors (1.7 m above the floor)

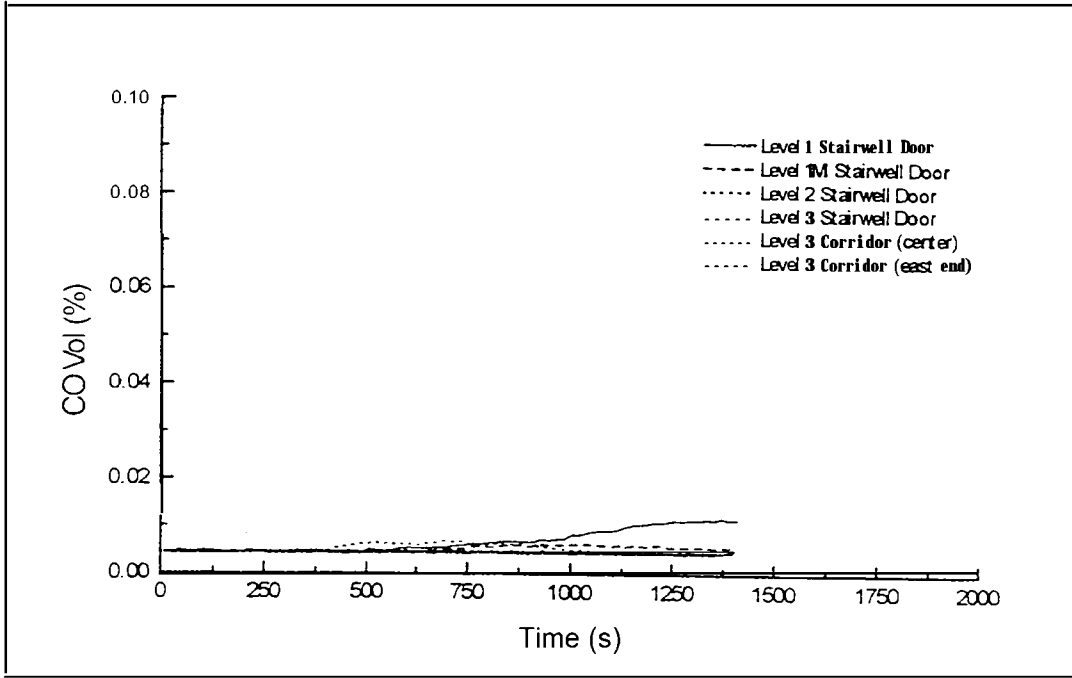

Figure FO6- 19: Carbon monoxide concentration at the stairwell doors ( 1.7 m above the floor)

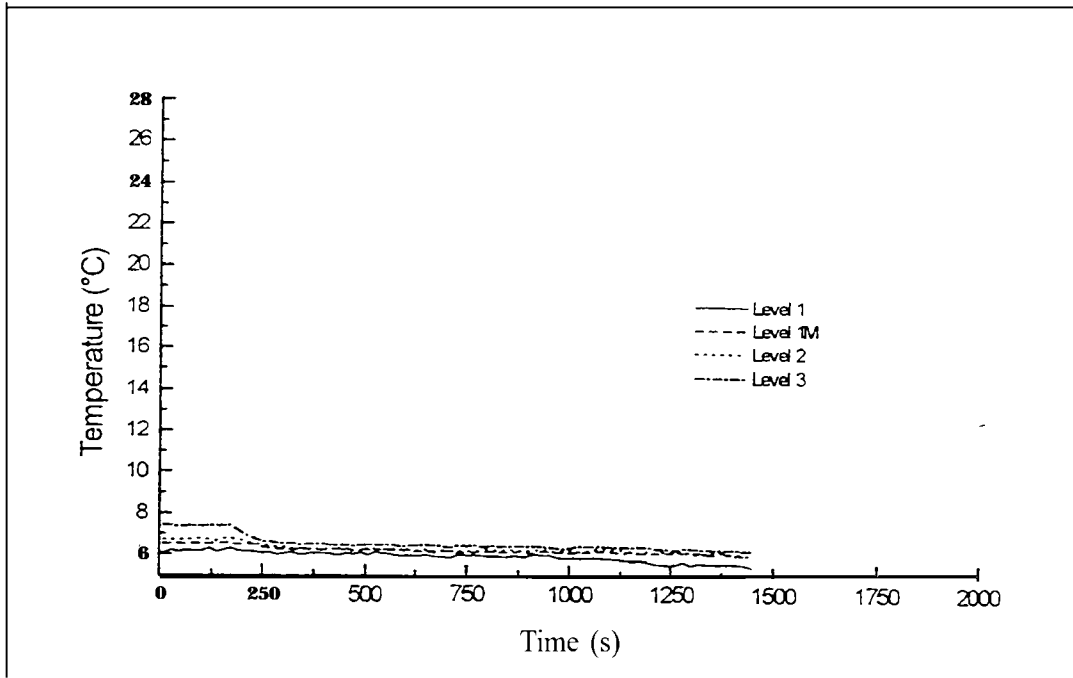

Figure FO6-20: Temperature in the stairwell at each level -North side (1.7 m above the floor)

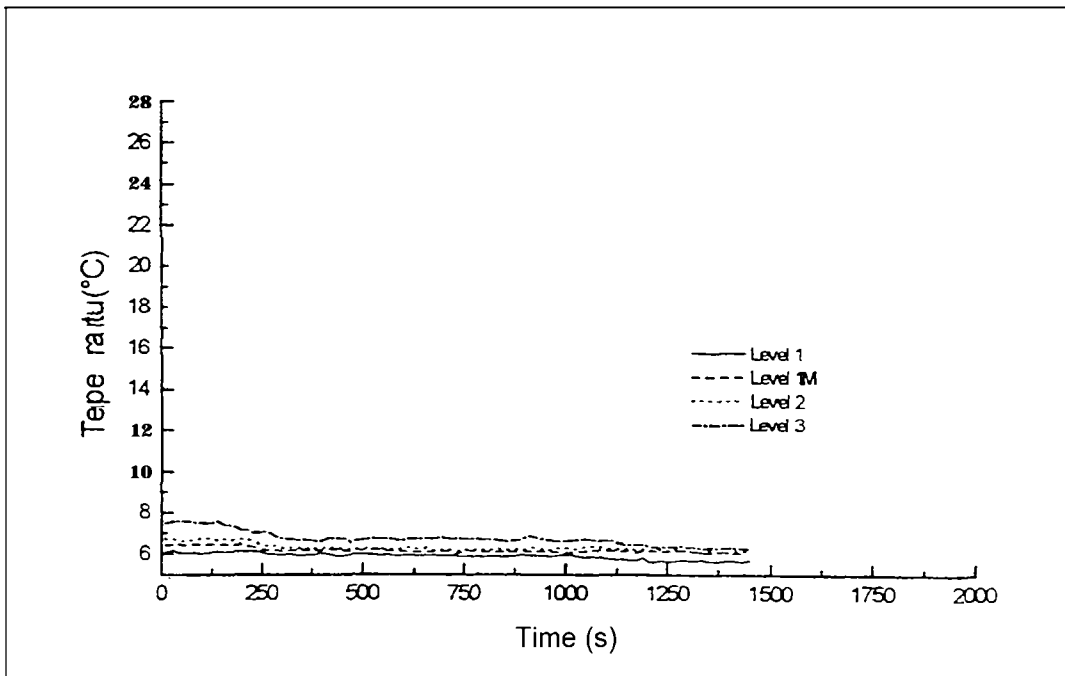

Figure FO6-21: Temperature in the stairwell at each level-South side (1.7 m above the floor)

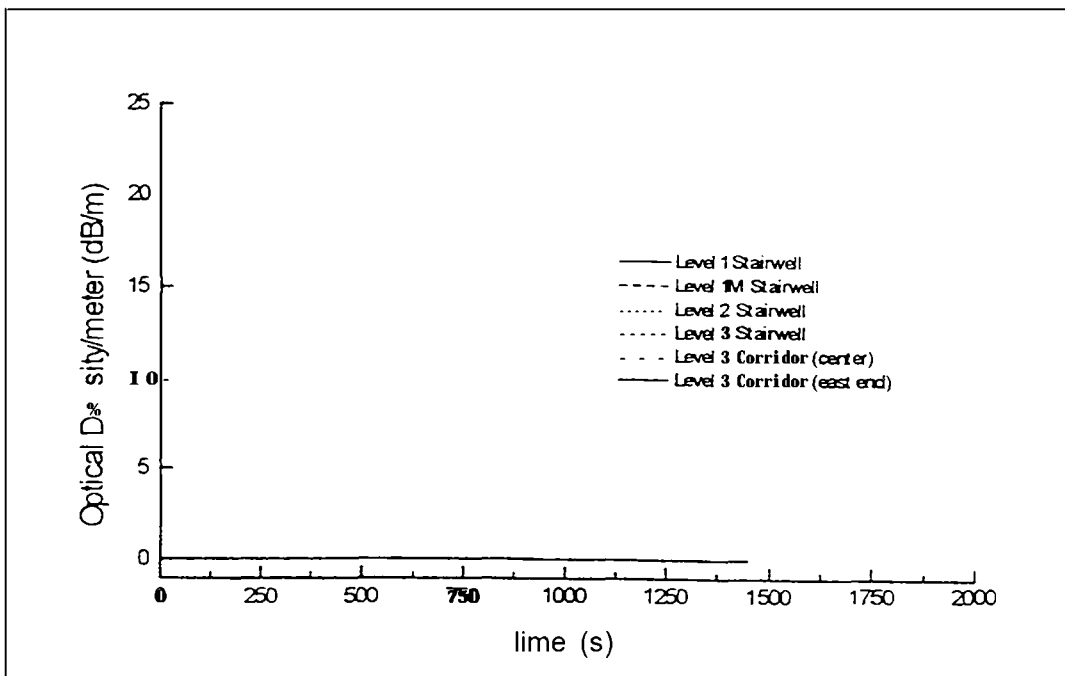

Figure FO6-22: Optical density/m at six locations (1.7 m above the floor)

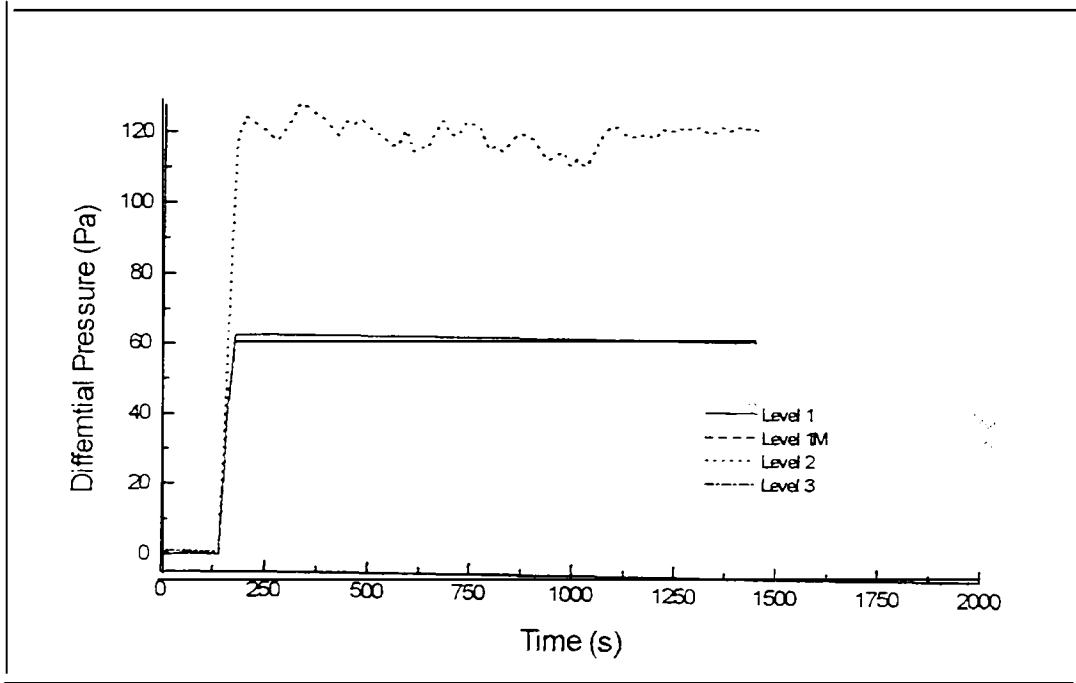

Figure FO6-23: Pressure differences between outside and the stairwell at each level (1.7 m above the floor)

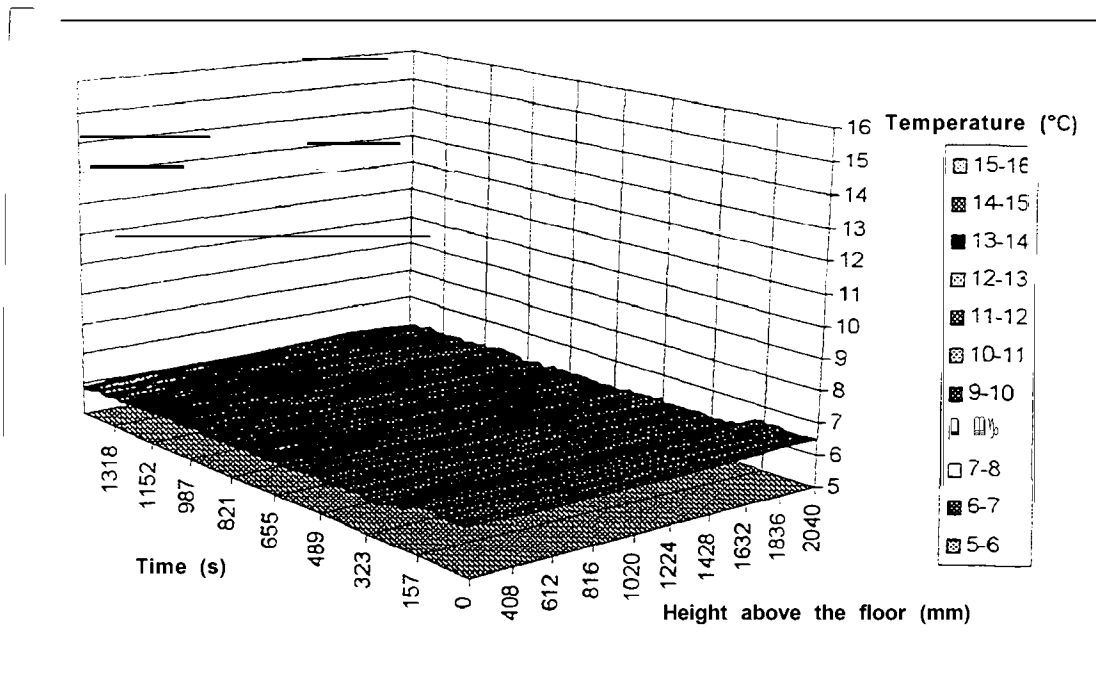

Figure FO6-24: Temperature distribution along the center line of Level 1M stairwell door

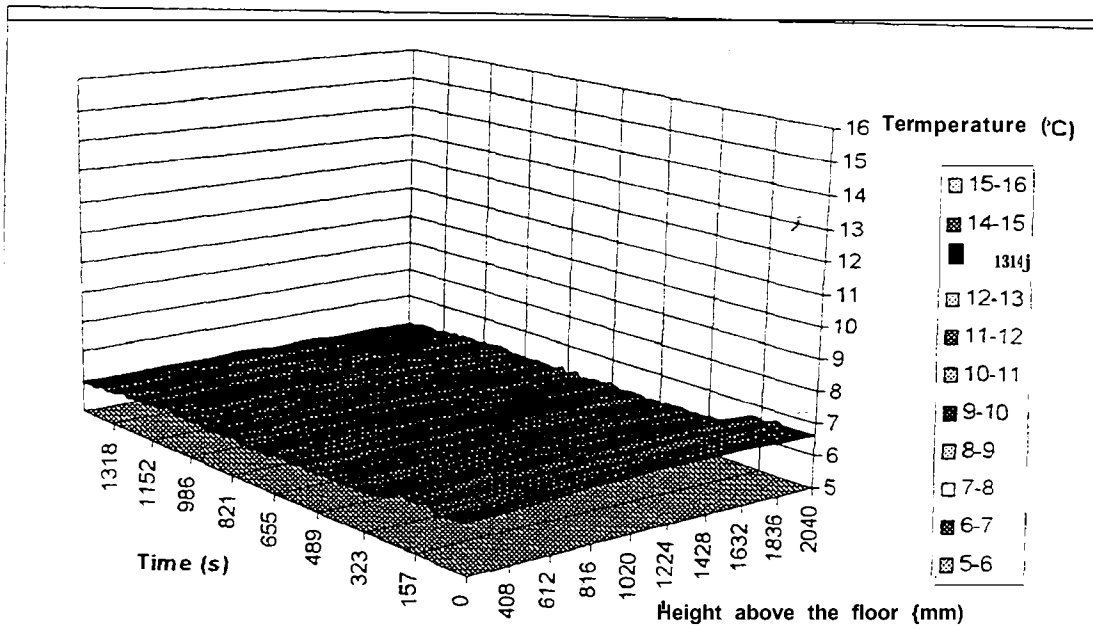

Figure FO6-25: Temperature distribution along the center line of Level 2 stairwell door

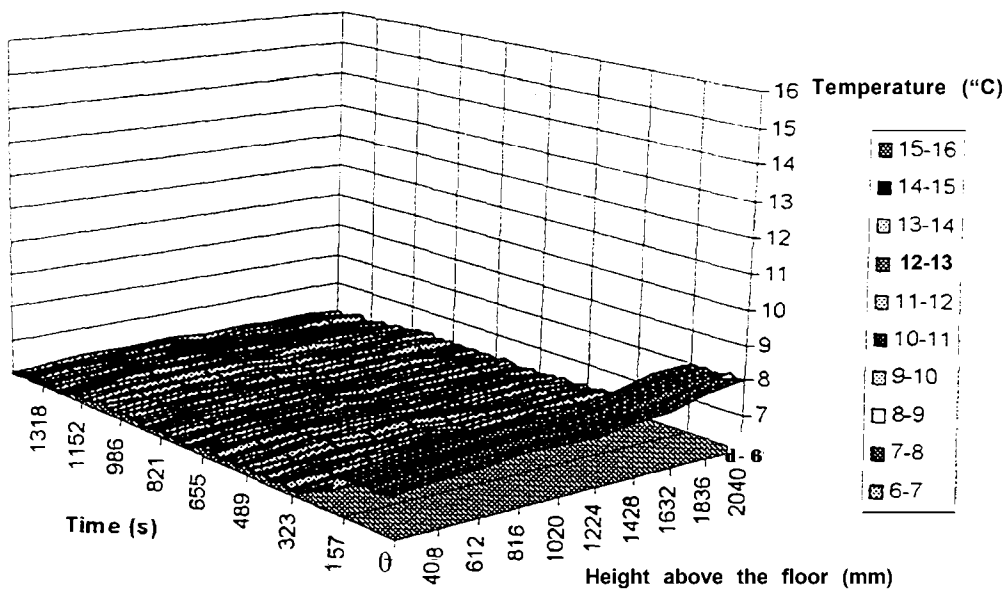

Figure FO6-26: Temperature distribution along the center line of Level 3 stairwell door

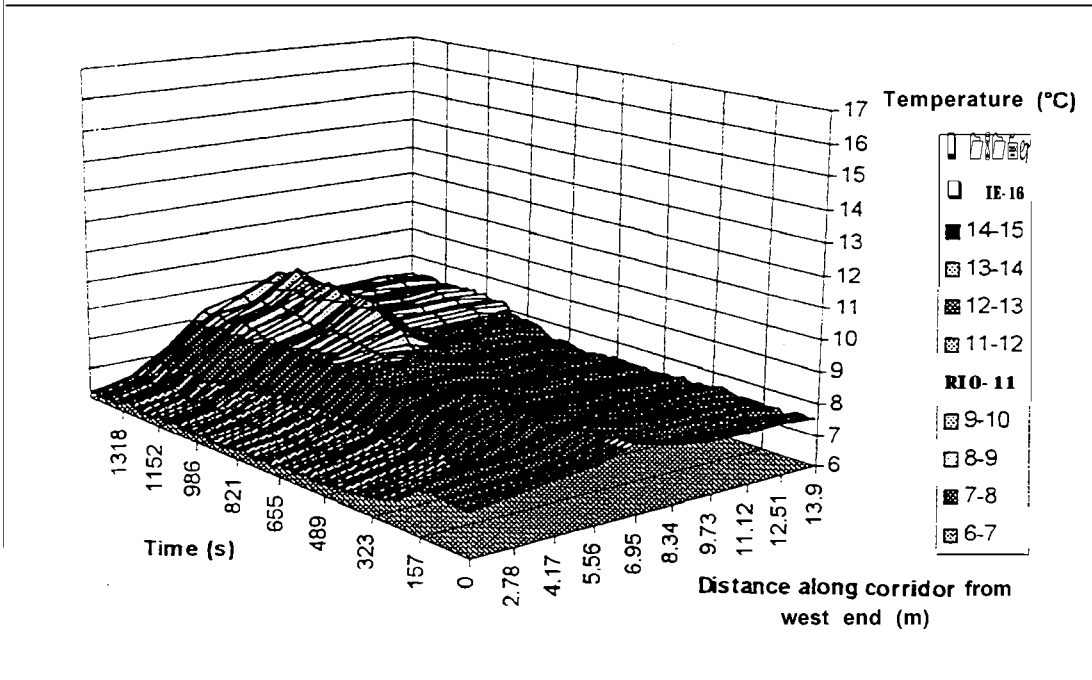

Figure FO6-27: Temperature distribution along Level 1M corridor (1.7 m above the floor)

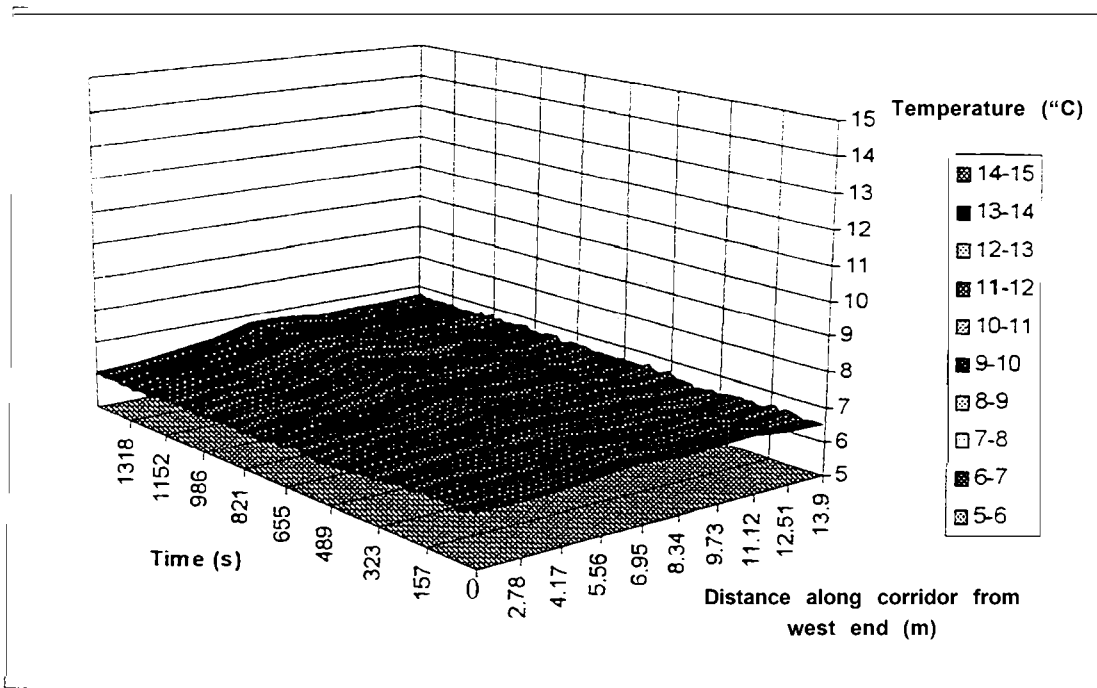

Figure FO6-28: Temperature distribution along Level 2 corridor (1.7 m above the floor)



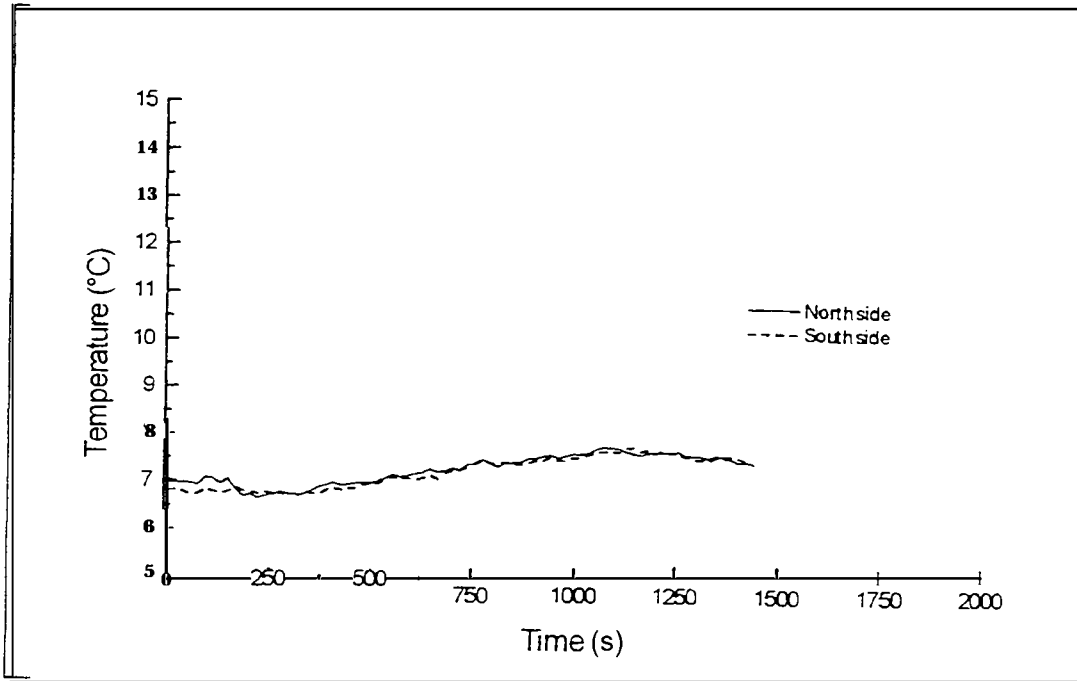

Figure FO6-29: Temperatures in Room 201 (1.7 m high)

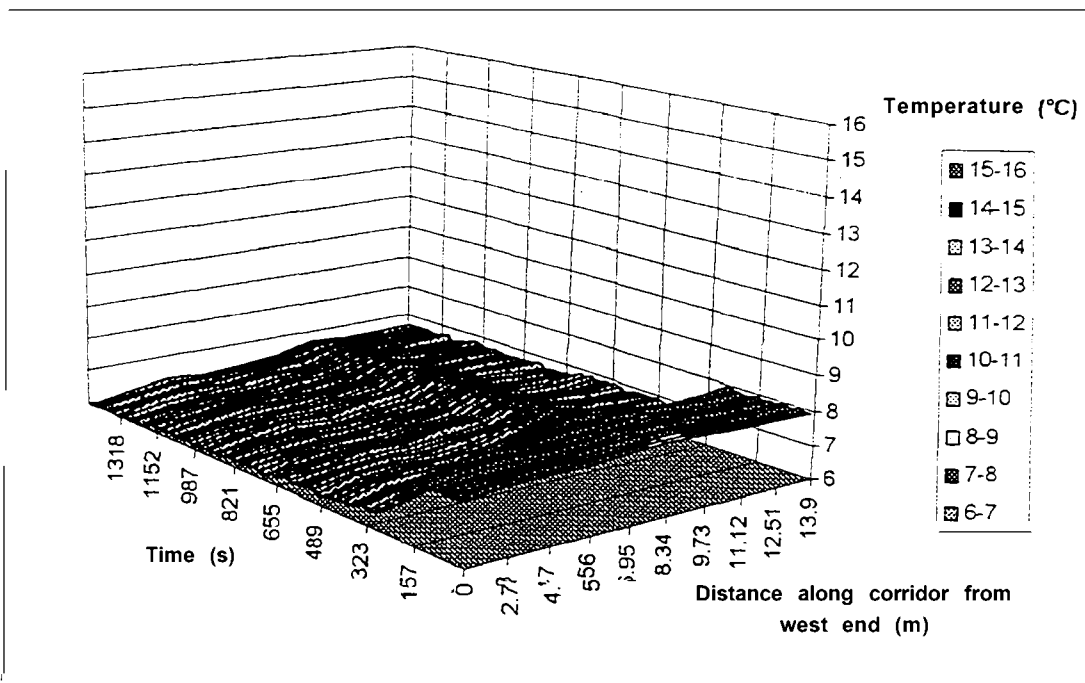

Figure FO6-30: Temperature distribution along Level 3 corridor (1.7 m above the floor)

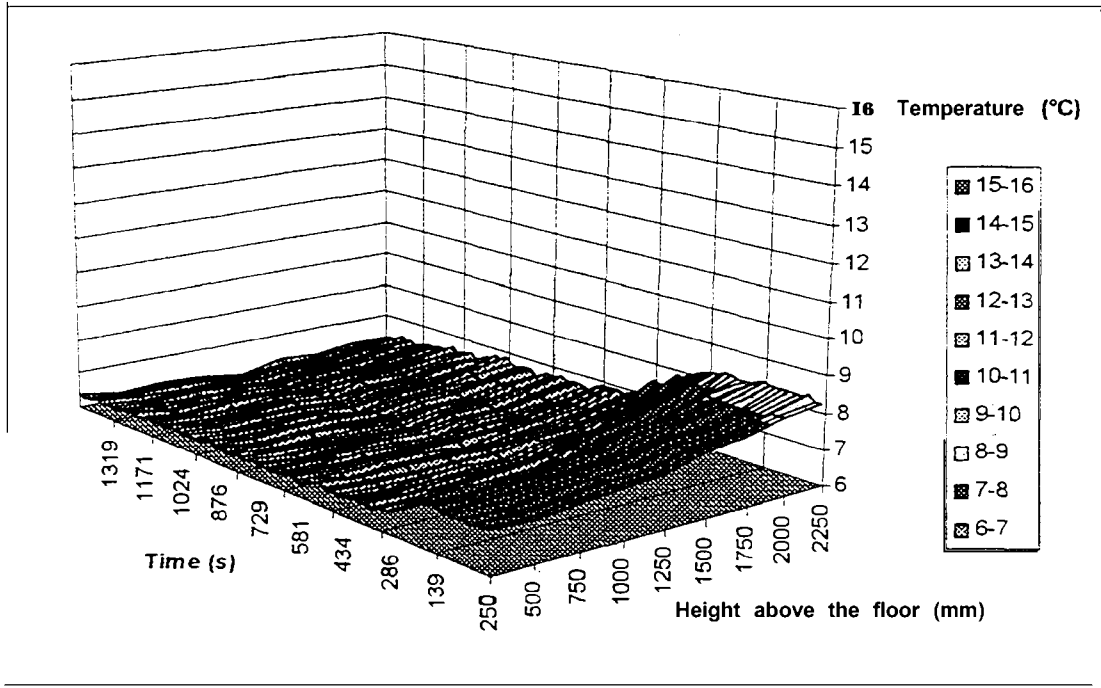

Figure FO6-31: Vertical temperature distribution in the center of Level 3 corridor

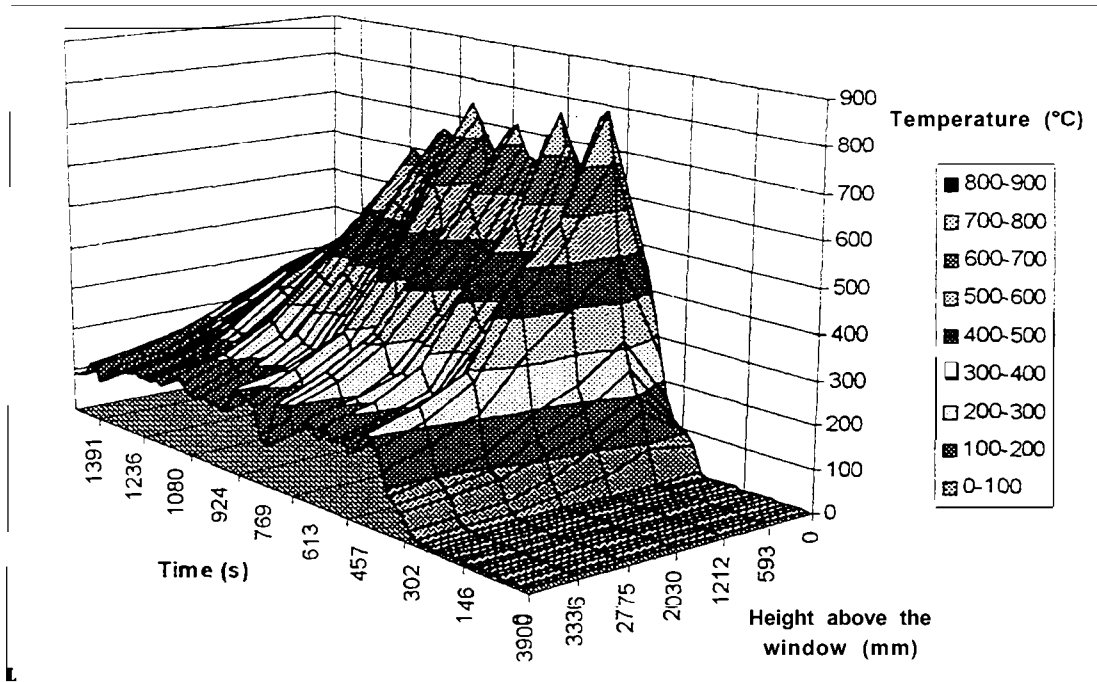

Figure FO6-32: External temperature along the center line of the bum room window (0.02 m from the wall)

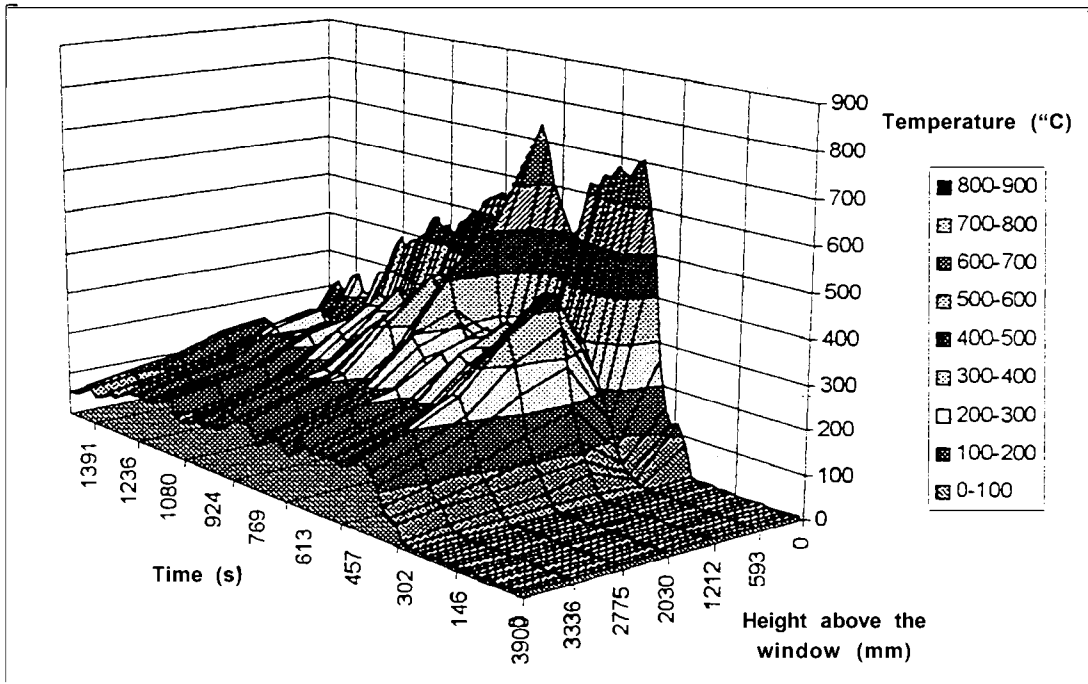

Figure FO6-33: External temperature along the center line of the bum room window (0.5 m from the wall)

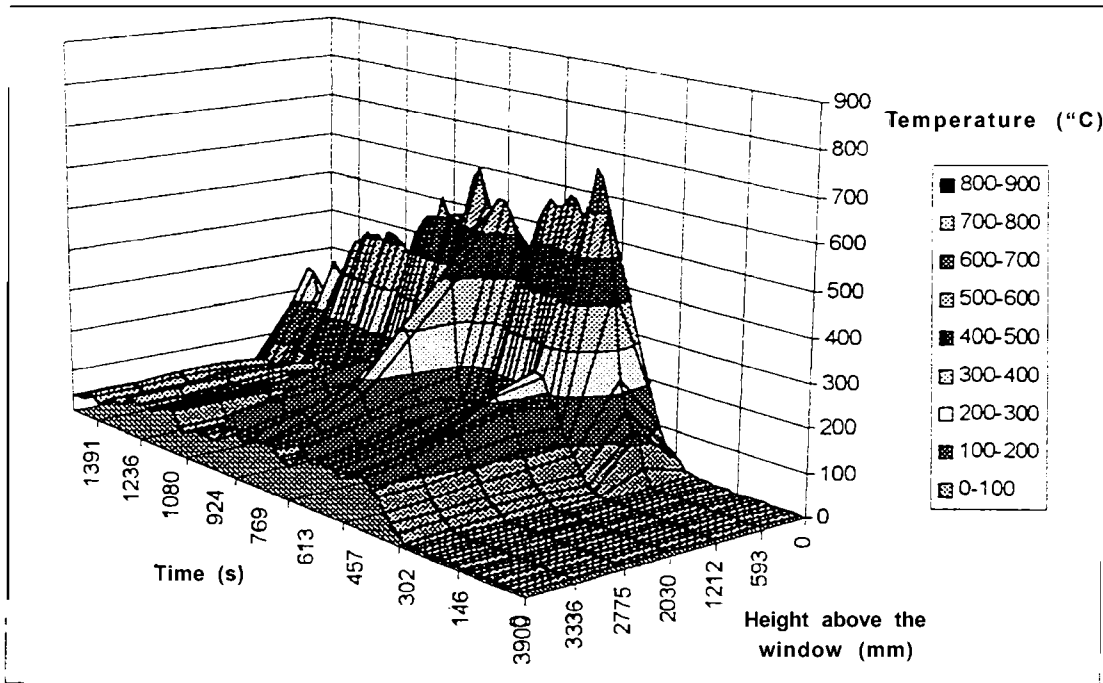

Figure FO6-34: External temperature along the center line of the bum room window (1.0 m from the wall)

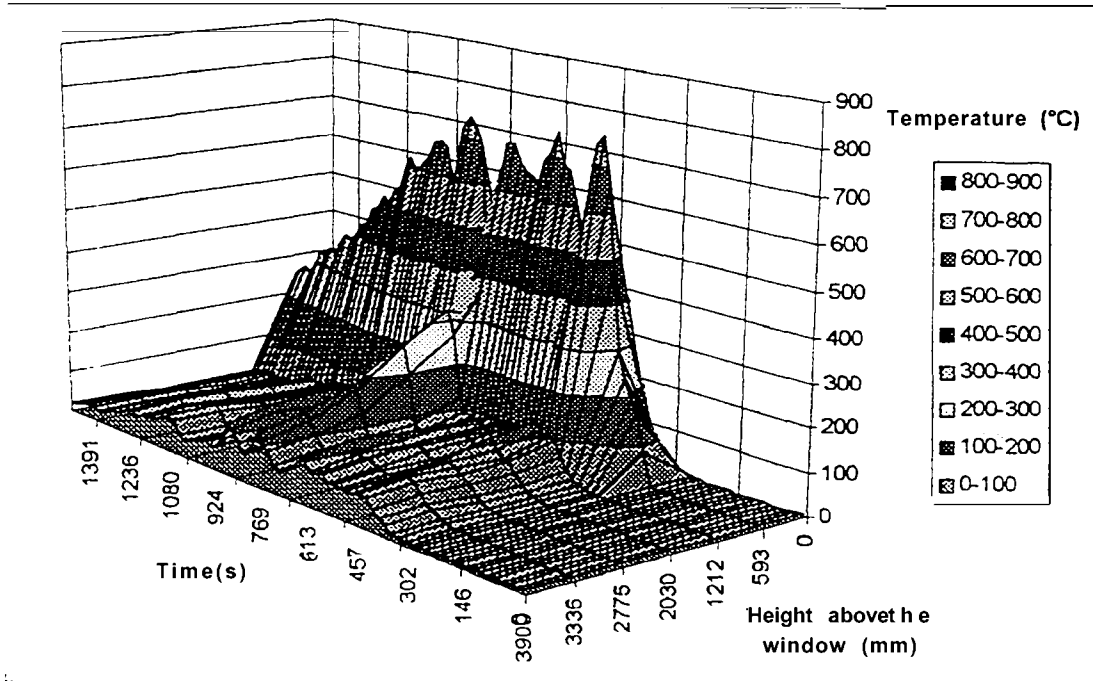

Figure FO6-35 : External temperature along the center line of the bum room window ( 1.5 m from the wall)

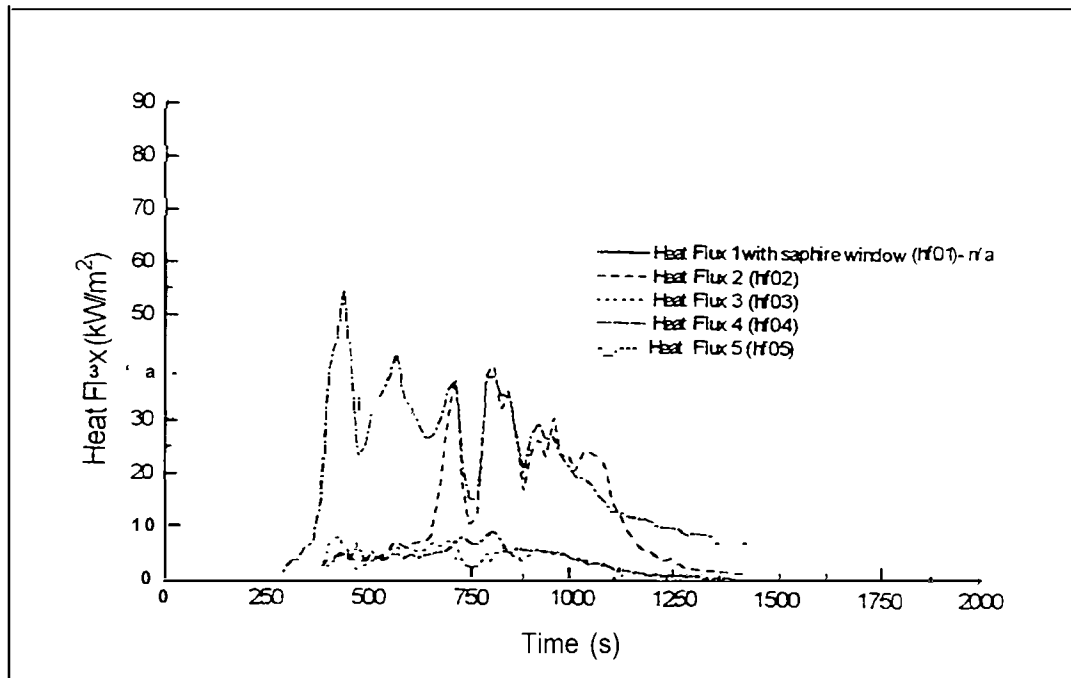

Figure FO6-36: External heat flux measurements (Refer to Figure 25 for locations)

## 15. Flashover Test F07

**Test Conditions:**     **Bum Room Door Open**  
                               **Level 1 Stairwell Door Open**  
                               **Combustible lining down Level 1 Corridor**

### Observations:

0:00 Ignition  
 0:40 Ionisation detector (no cap) activated  
 3:30 Smoke layer reaching the top of the window (0.4 m from ceiling)  
 4:15 Sprinkler above the small platform activated (detection only)  
 4:40 Initial crack in middle pane  
       Smoke to the top of the couch (1.45 from ceiling)  
 4:50 Sprinkler above the large platform activated (detection only)  
 5:00 More cracking in the middle pane, room full of smoke  
 5:15 Sprinkler in Level 1 corridor activated (detection only)  
 5:30 Window lowered  
 6:30 Flames 0.6 m high above the window opening  
 7:50 Flashover occurs  
 9:30 Flames 2.0 m high above the window opening  
 9:45 Initial dislodgment of IM window  
 11:30 More IM dislodgment  
 14:10 More IM dislodgment from left and middle panes  
 14:15 Little flaming coming out of bum room window; mostly hot gases

15:00 Smoke begins to enter Level 3 corridor  
 17:00 Level 3 corridor full of smoke

The top half of the combustible wall lining in Level 1 corridor burnt away (ie-approximately 1200 mm from the ceiling was fully burnt). Despite the added fuel load in the corridor the P/U was undamaged as was the carpet which had a few char marks on it.

**Table 13: Summary of results for Test F07**

<b>In the Burn Room</b>	
Maximum Heat Release Rate	15.3 MW
Maximum Peak Temperature	1095 °C
Maximum Average Room Temperature	966°C
Minimum Oxygen Concentration	0.7 Vol %
Maximum Total Heat Flux	109 kW/m <sup>2</sup>
Time untenability reached (100°C)	270 s

<b>At the Burn Room Door</b>		
Maximum CO Concentration a		6.5 Vol %
Maximum CO <sub>2</sub> Concentration		13 Vol %
Maximum Temperature		970 °C
Minimum Oxygen Concentration		0.6 Vol %
<b>In Level 1 Corridor</b>		
Maximum Temperature 1.5 m above the floor		630 °C
Maximum Temperature in the center of the Corridor		640 °C
<b>Stairwell</b>		
Maximum Temperature	Level 1	164 °C
	Level 1M	137 °C
	Level 2	57 °C
	Level 3	52 °C
<b>Level 3 Corridor</b>		
Maximum Temperature		43 °C
<b>External</b>		
Maximum External Temperature		890 °C
Maximum Total Heat Flux		55 kW/m <sup>2</sup>

Note: A full list of detector and sprinkler activation times is shown in Table 15 & 16. Only the time for the first detector activated is listed in the above observations.

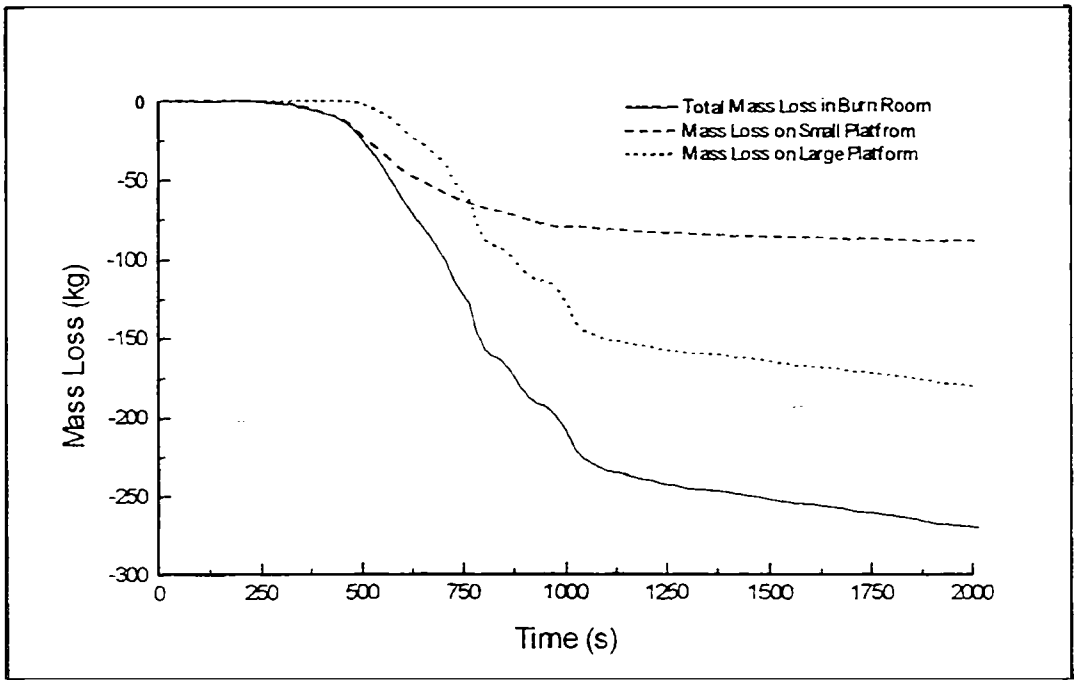

Figure FO7- 1: Combined mass loss in the bum room

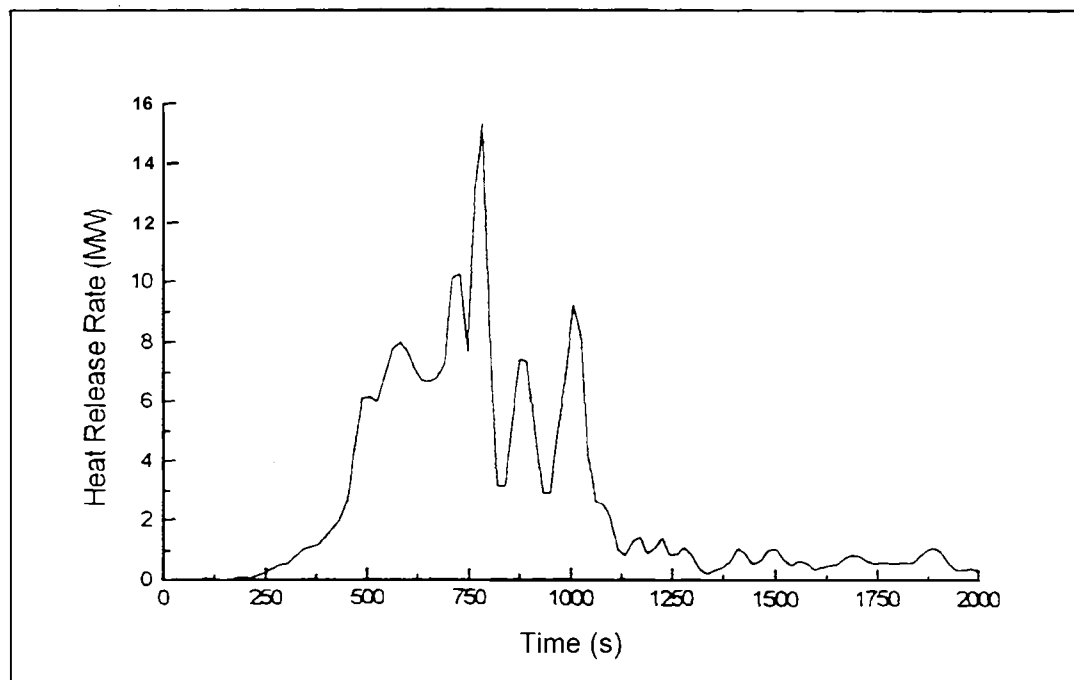

Figure FO7-2: Total heat release rate in the bum room

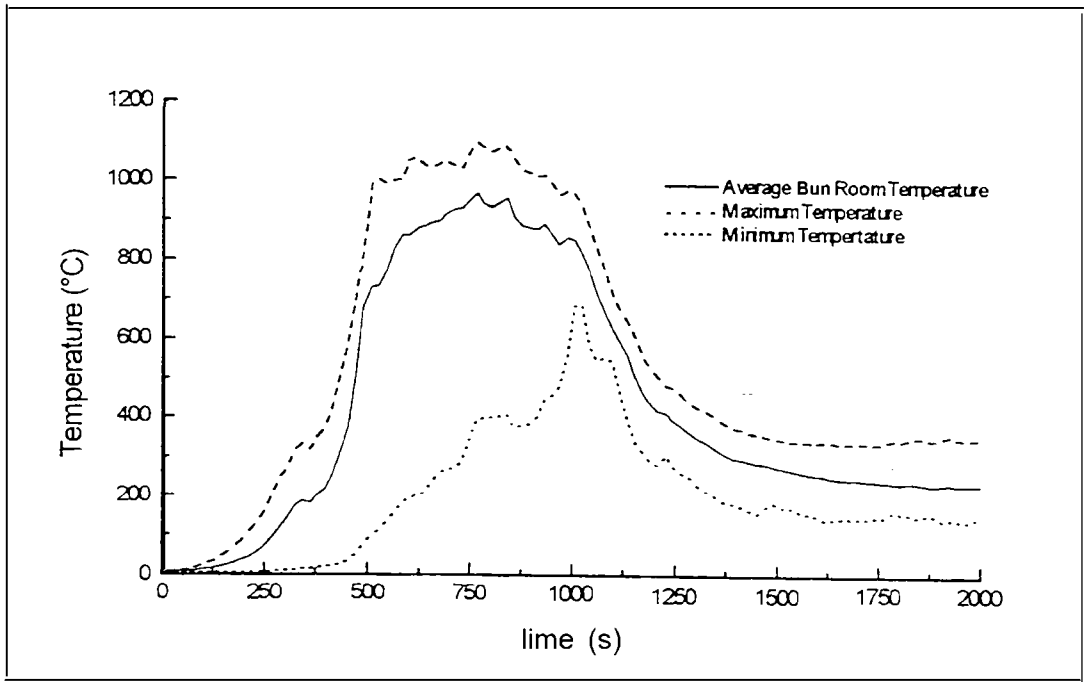

Figure FO7-3: Average, maximum and minimum temperatures in the burn room

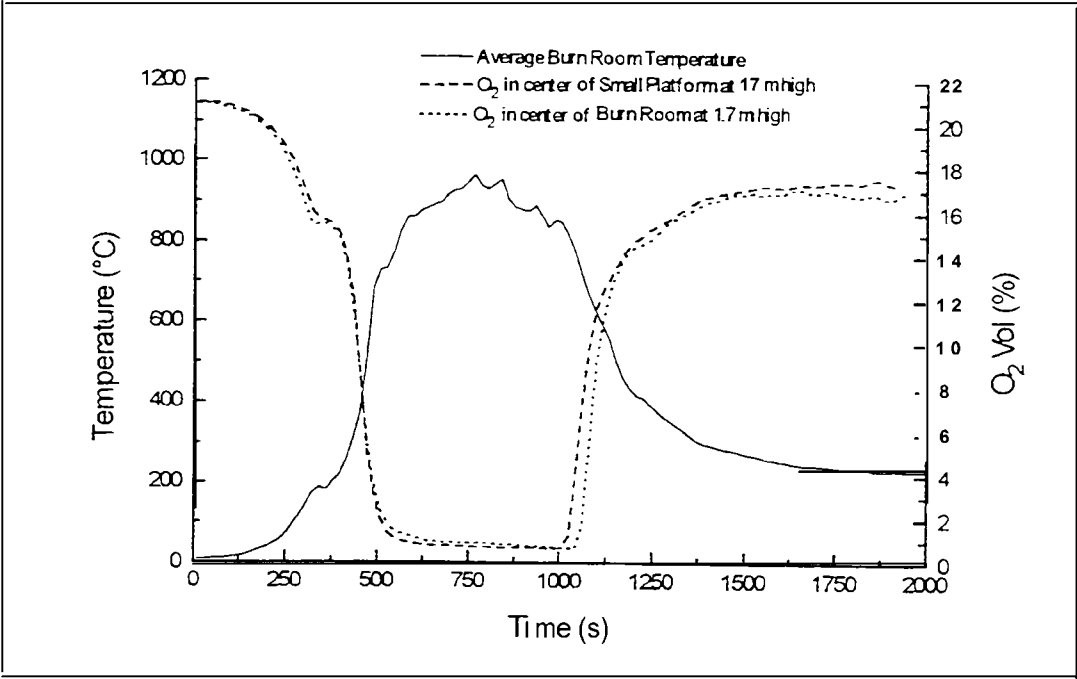

Figure FO7-4: Oxygen concentration and average temperature in the burn room



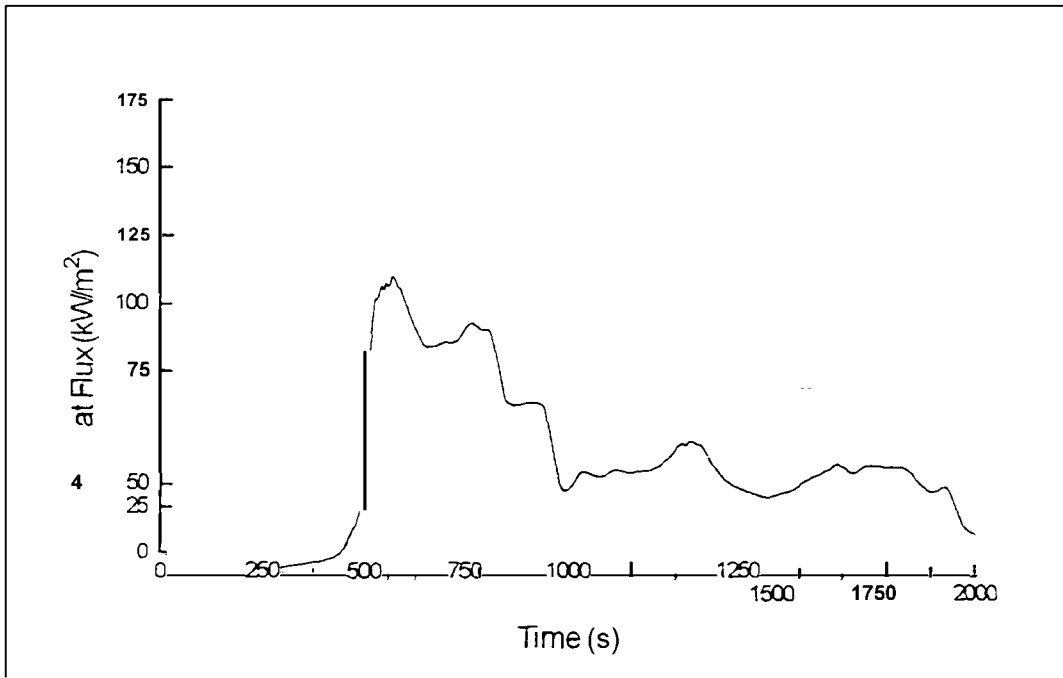

Figure FO7-5: Total heat flux in the center of the bum room

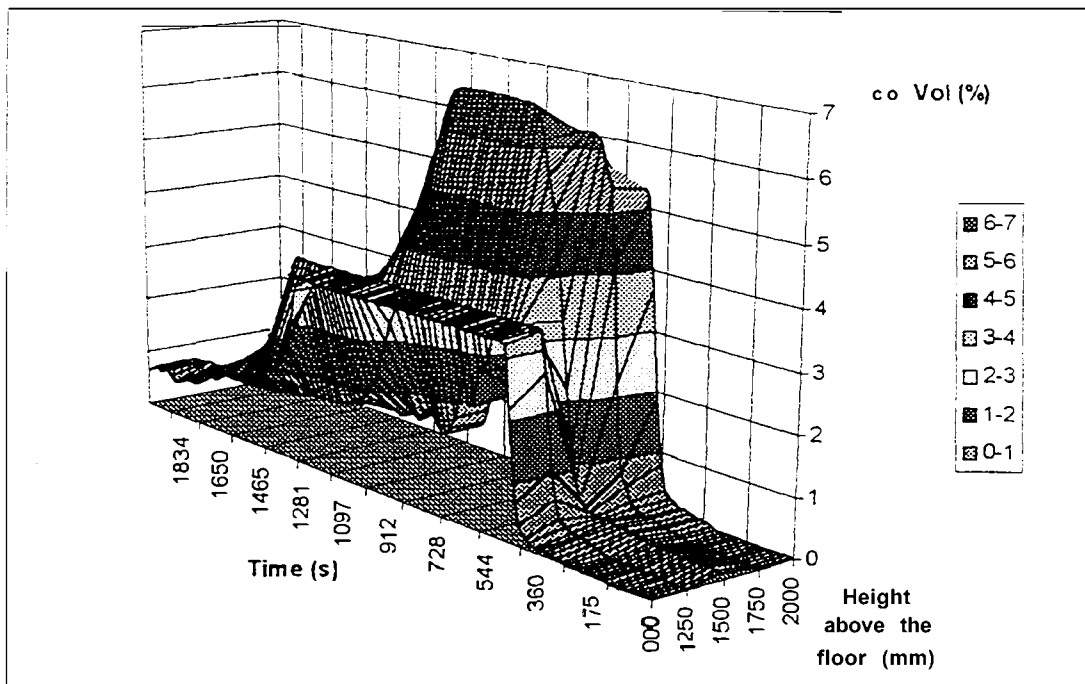

Figure FO7-6: Carbon monoxide concentration along the center line of the bum room door

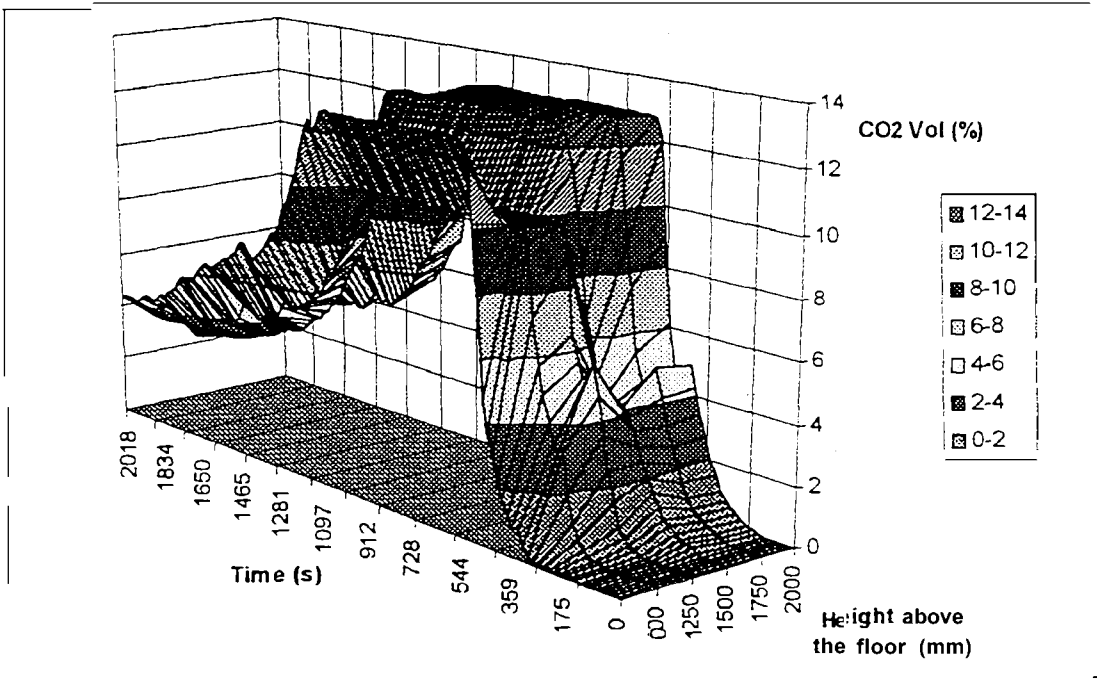

Figure FO7-7: Carbon dioxide concentrations along the center line of the bum room door

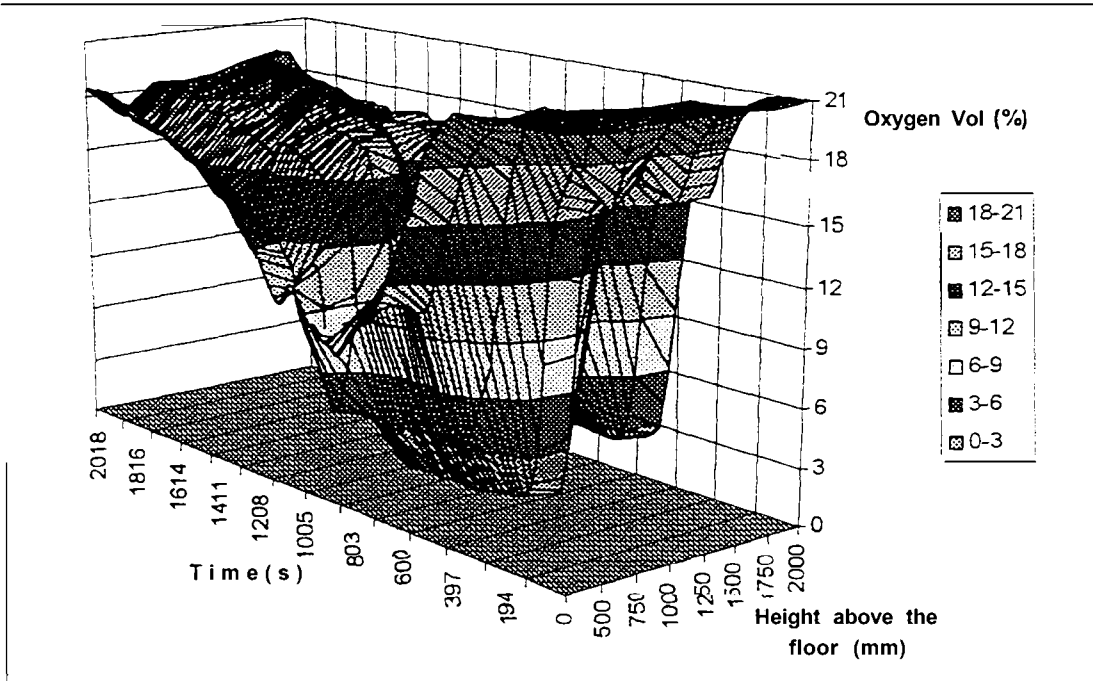

Figure FO7-8: Oxygen concentrations along the center line of the bum room door

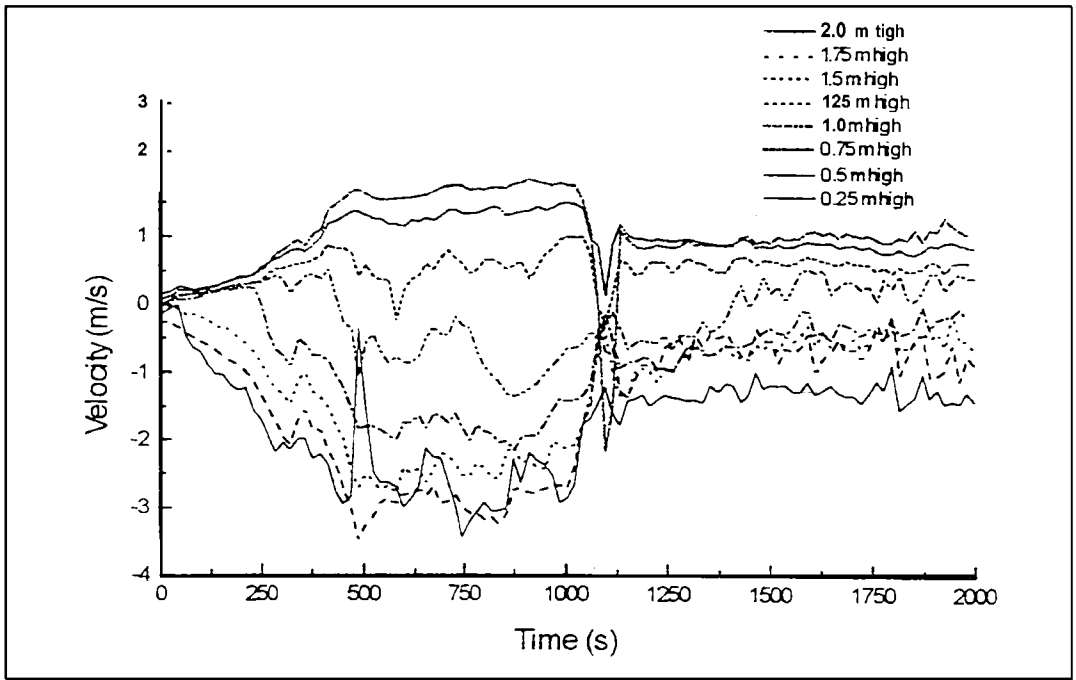

Figure FO7-9: Flow velocity distribution at the center line of the bum room door

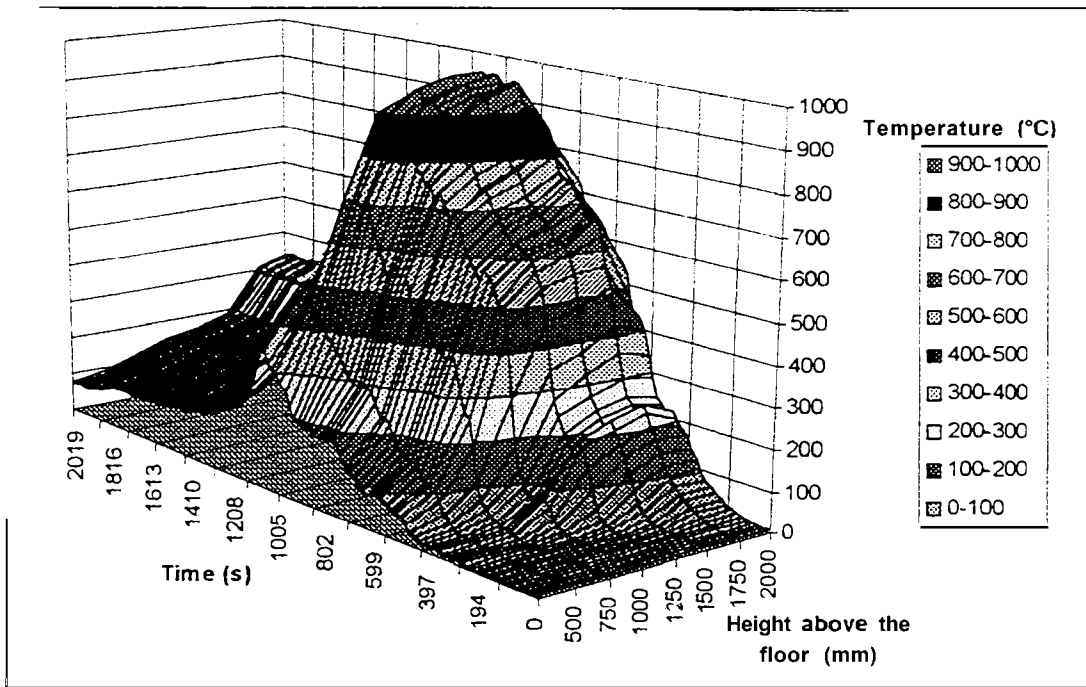

Figure FO7-10: Temperature distribution along the center line of the bum room door

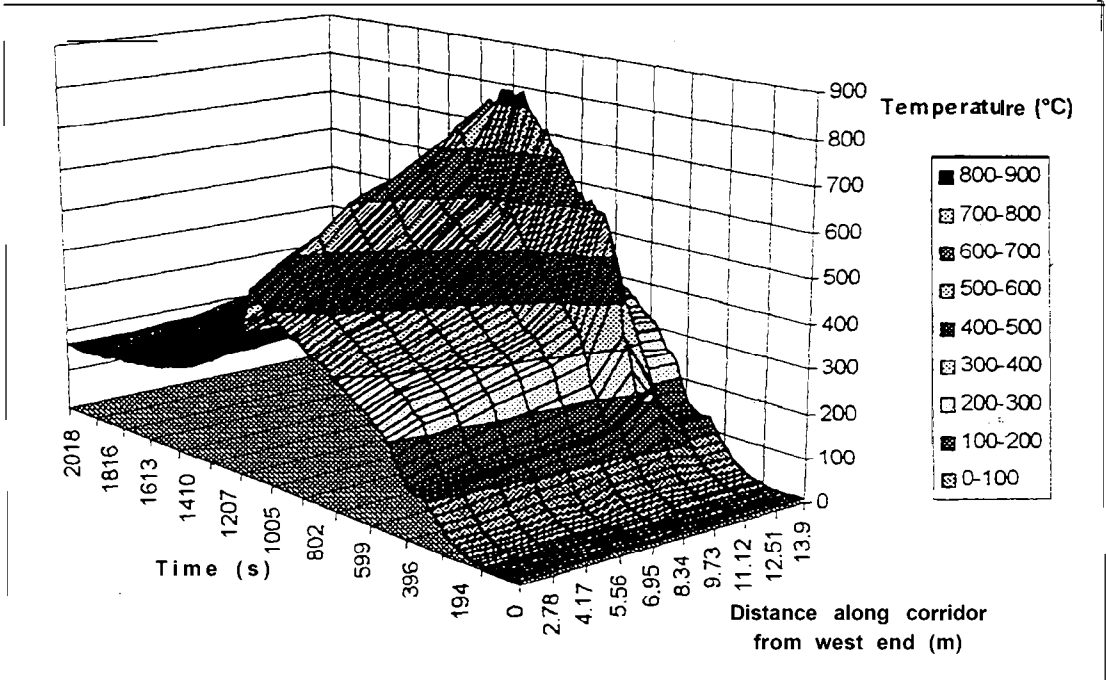

Figure FO7-11: Temperature along Level 1 corridor (2.0 m above the floor)

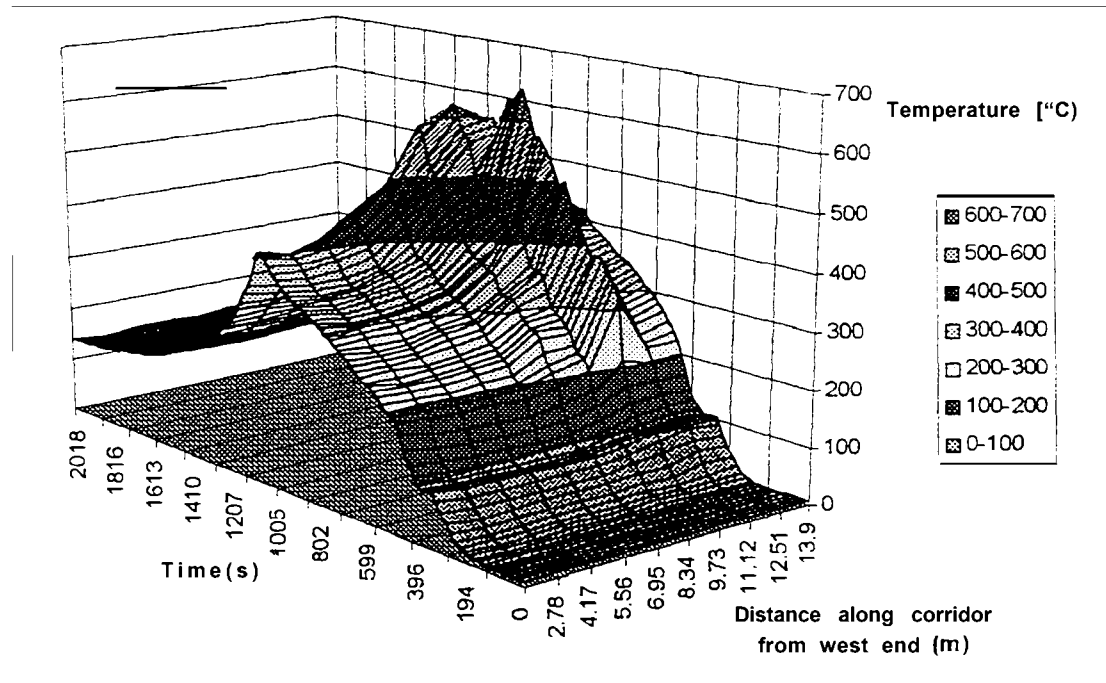

Figure FO7-12: Temperature along Level 1 corridor (1.5 m above the floor)

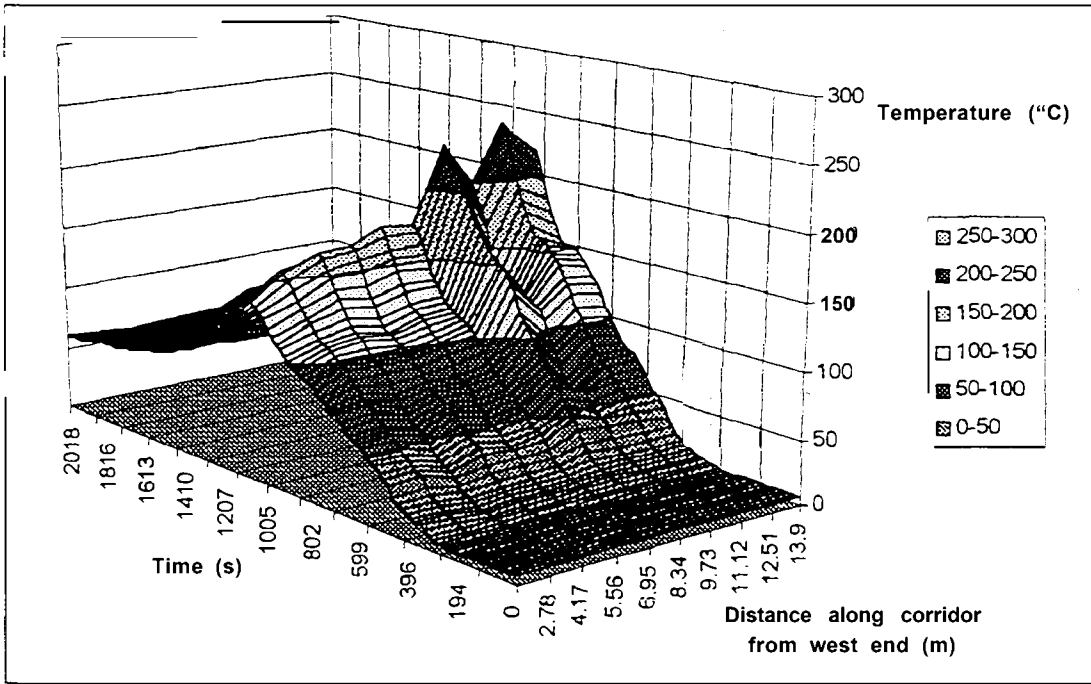

Figure FO7-13: Temperature along Level 1 corridor (0.5 m above the floor)

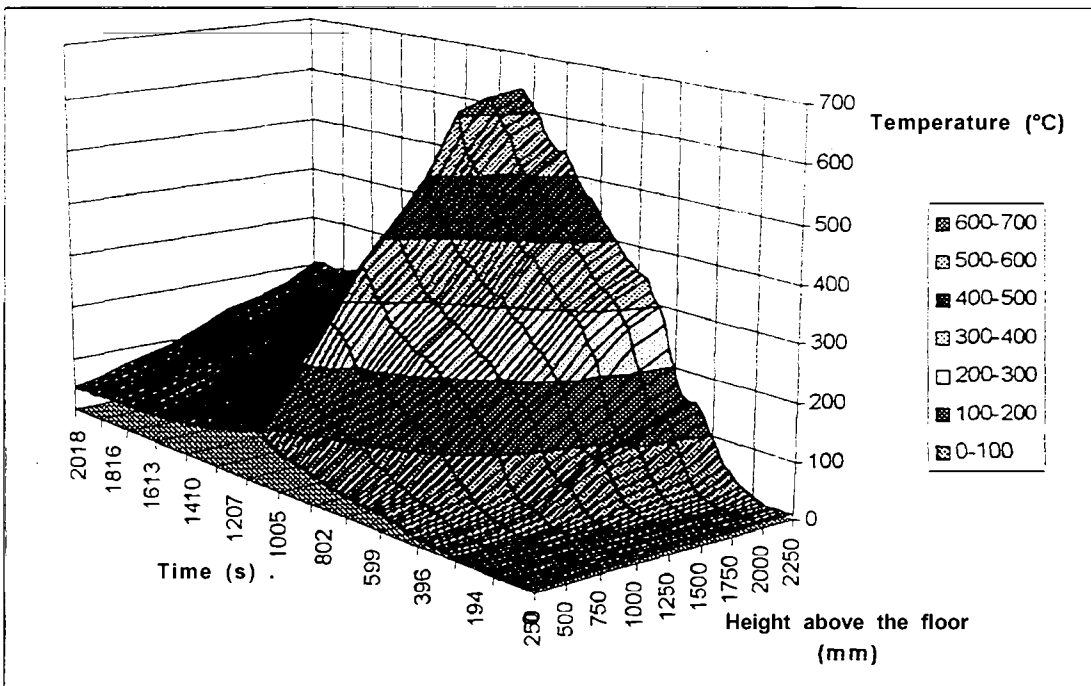

Figure FO7-14: Vertical temperature distribution in the center of Level 1 corridor

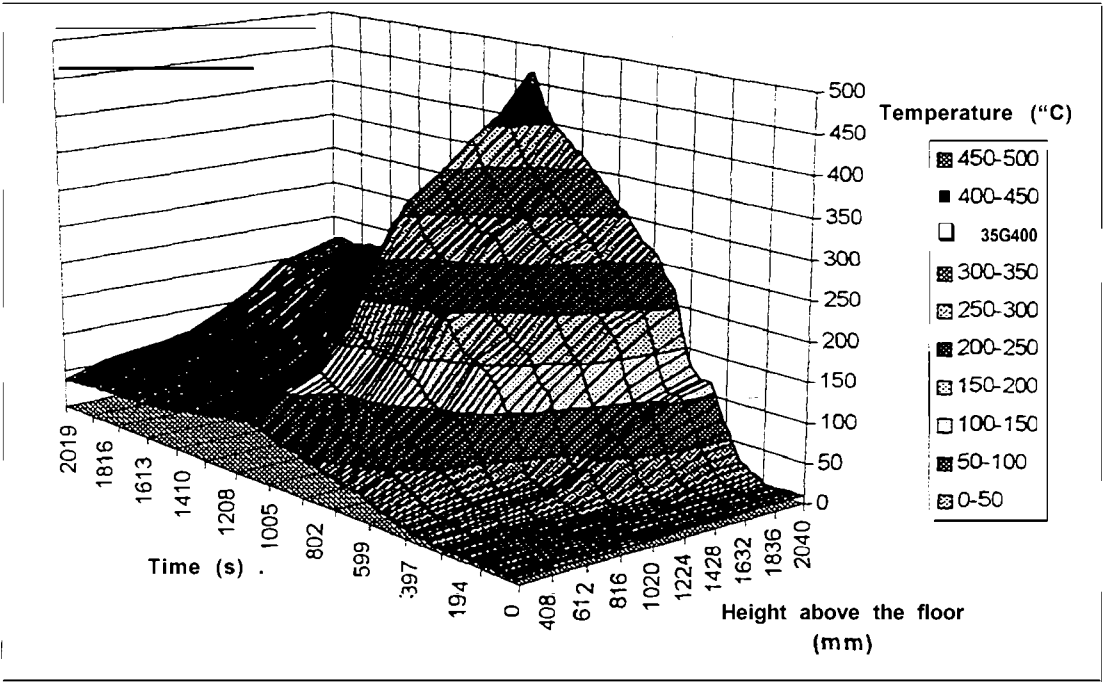

Figure FO7-15: Temperature distribution along the center line of Level 1 stairwell door

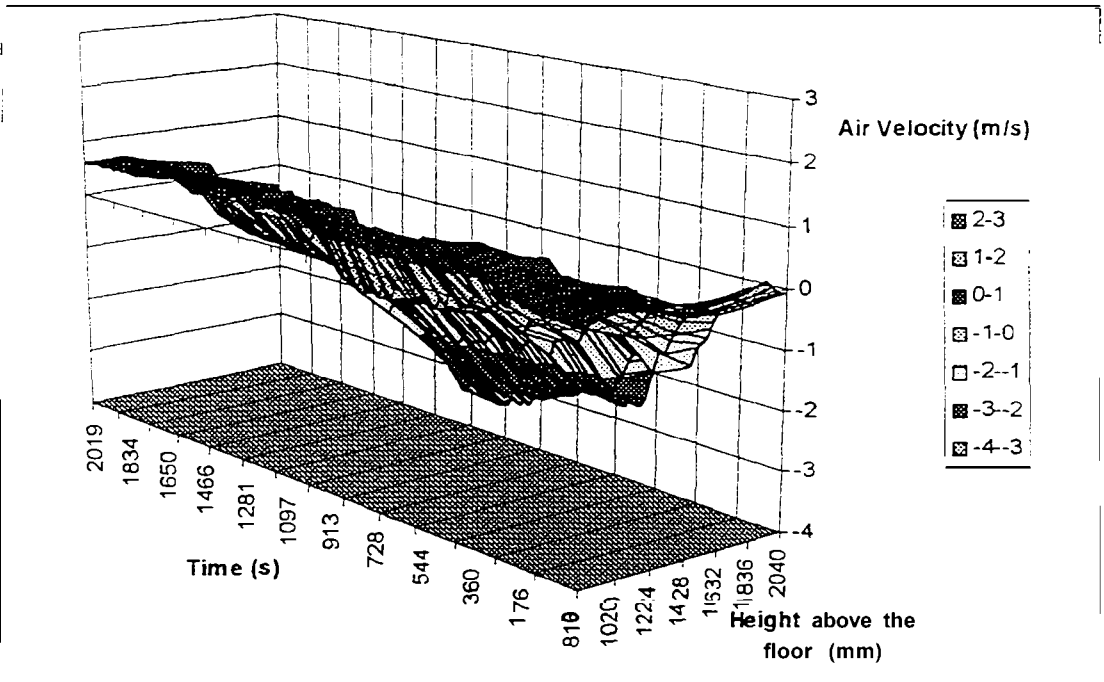

Figure FO7-16: Flow velocity distribution at the center line of Level 1 stairwell door

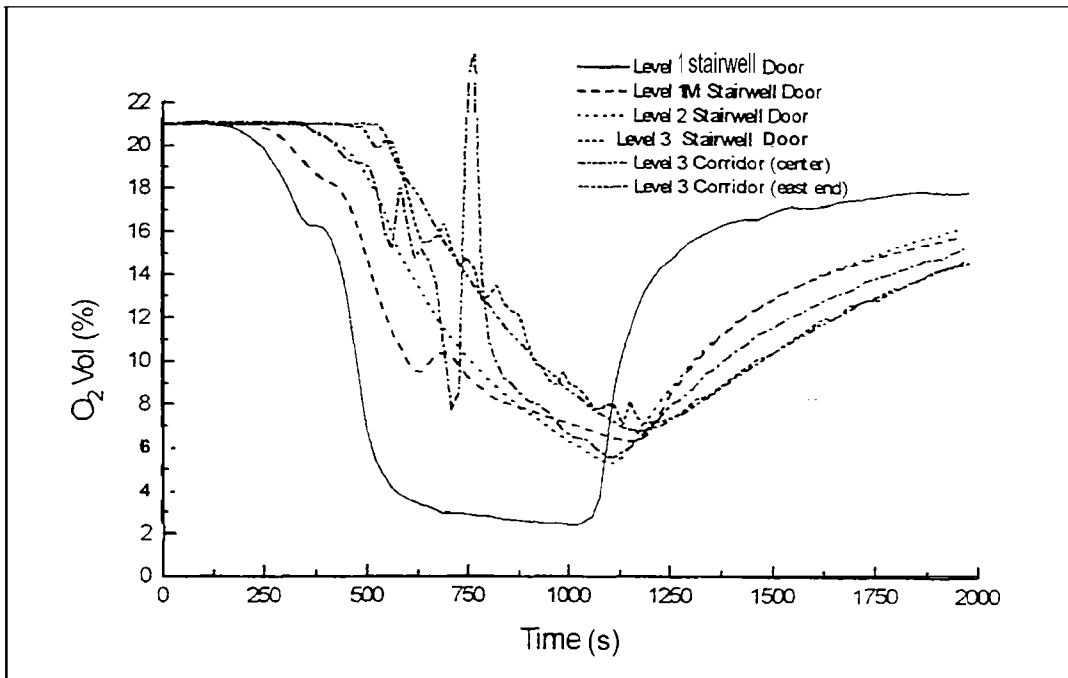

Figure FO7-17: O<sub>2</sub> concentration at the stairwell doors (1.7 m above the floor)

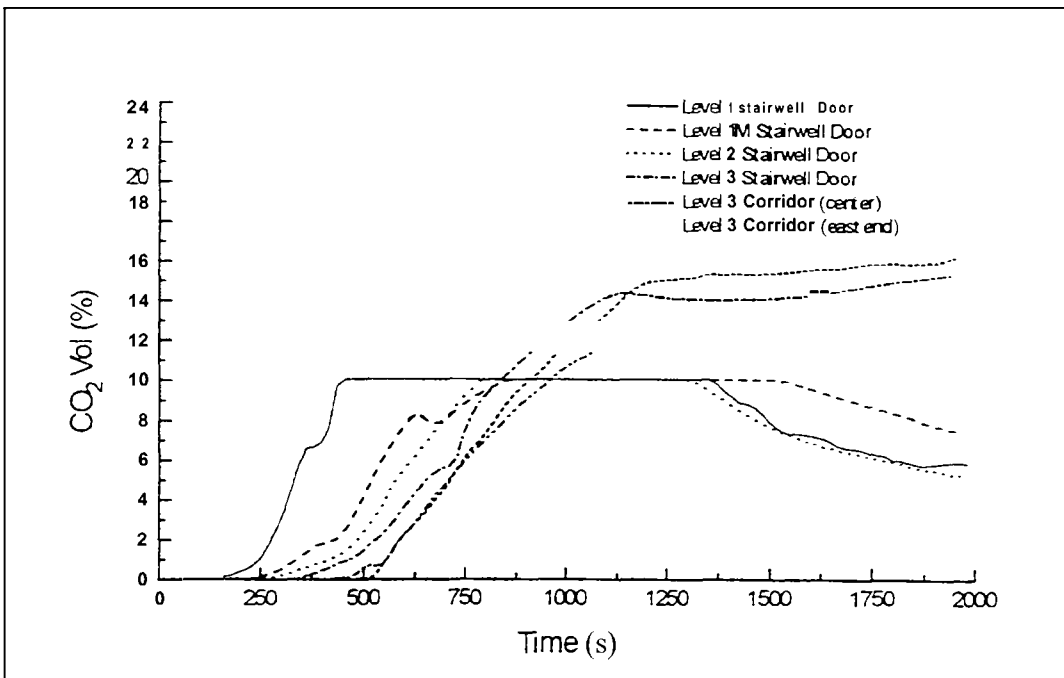

Figure FO7-18: Carbon dioxide concentration at the stairwell doors (1.7 m above the floor)

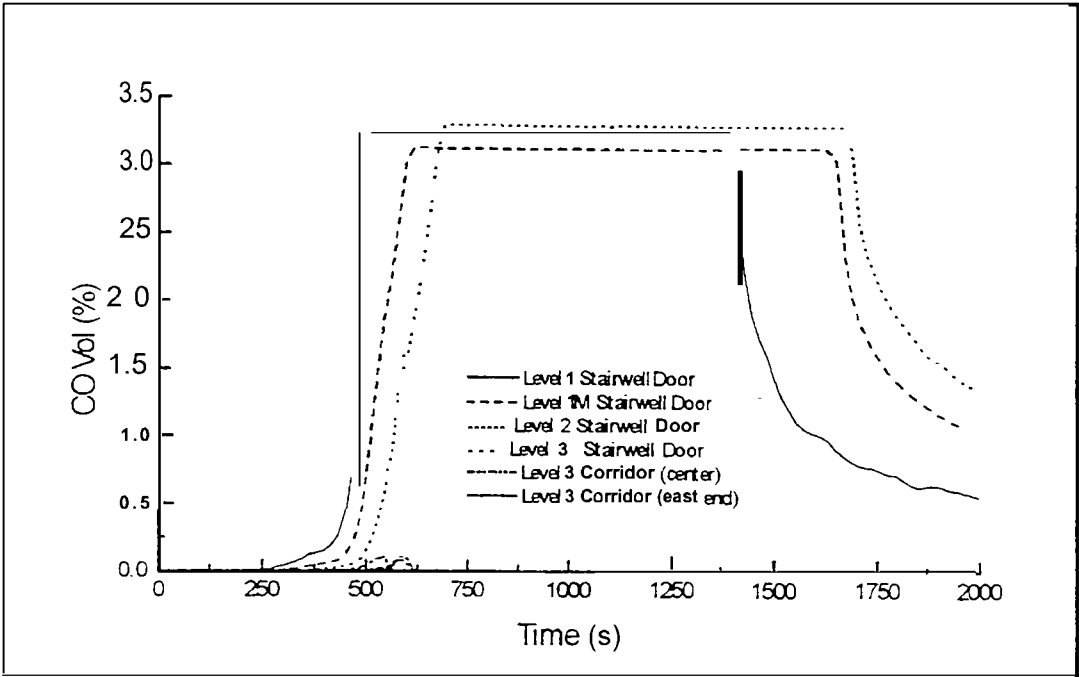

Figure FO7-19: Carbon monoxide concentration at the stairwell doors (1.7 m above the floor)

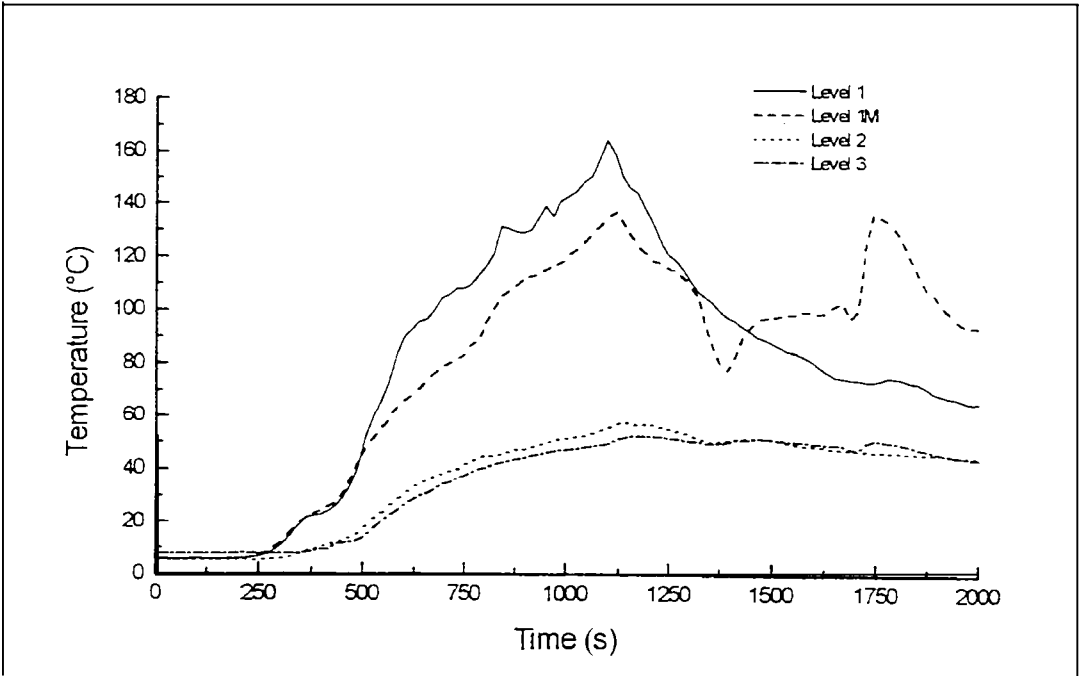

Figure FO7-20: Temperature in the stairwell at each level -North side (1.7 m above the floor)



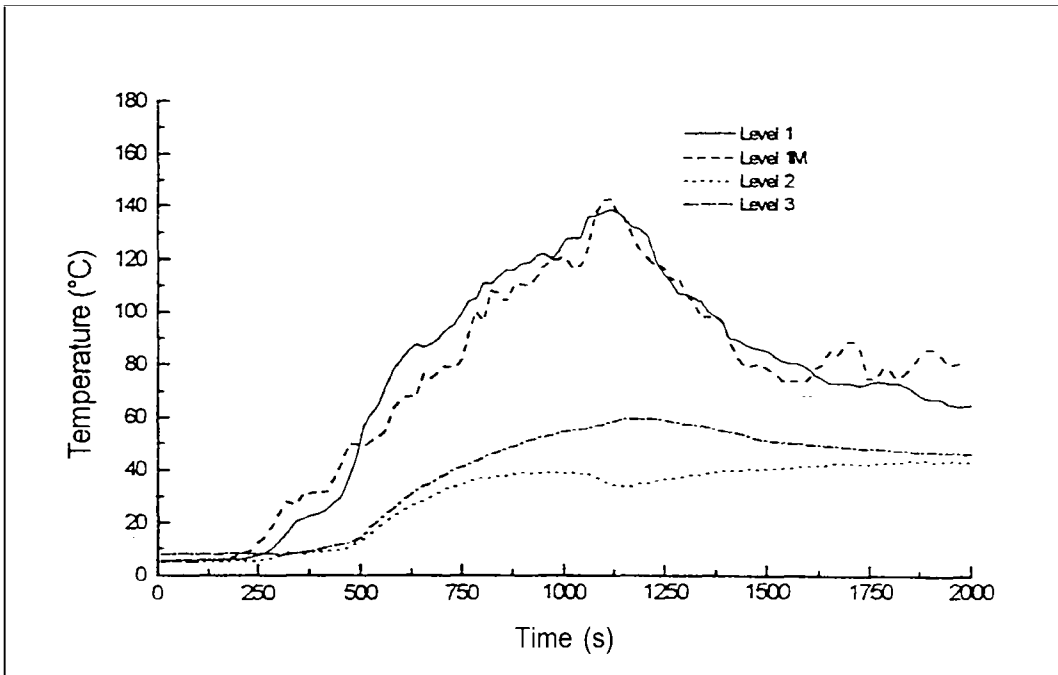

Figure FO7-2 1: Temperature in the stairwell at each level-South side (1.7 m above the floor)

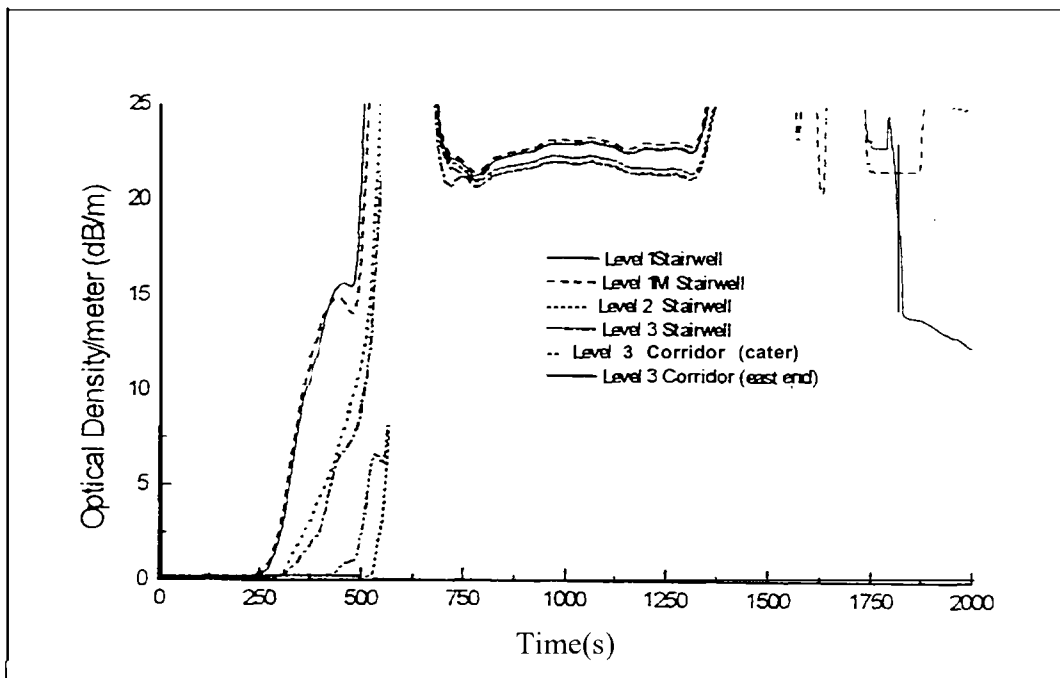

Figure FO7-22: Optical density/m at six locations (1.7 m above the floor)

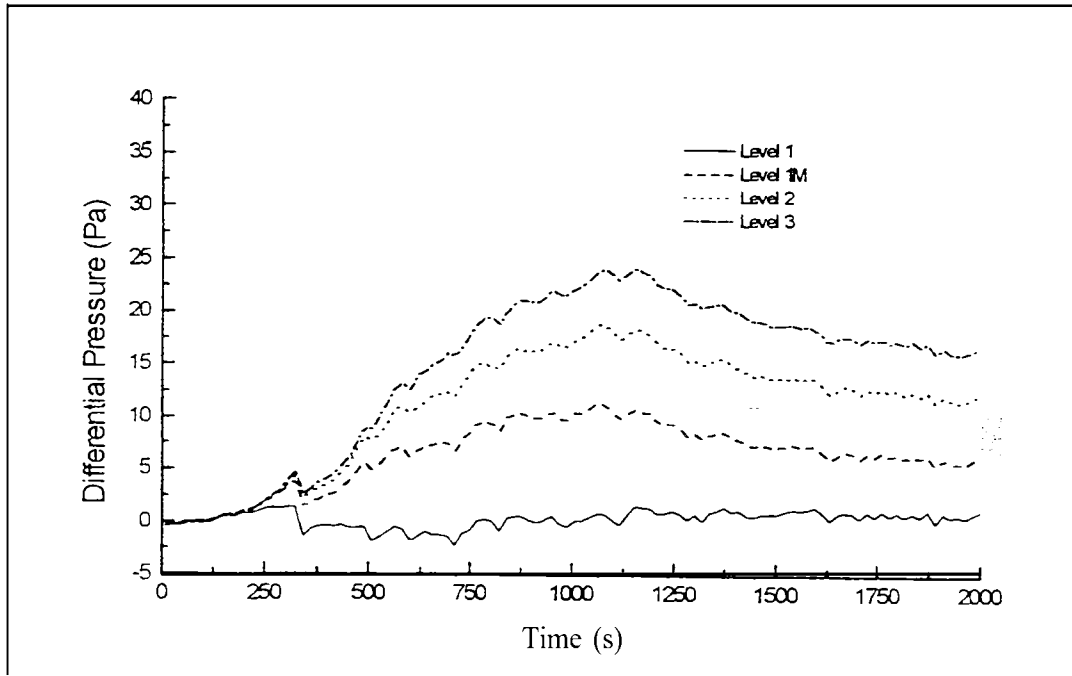

Figure FO7-23: Pressure differences between outside and the stairwell at each level (1.7 m above the floor)

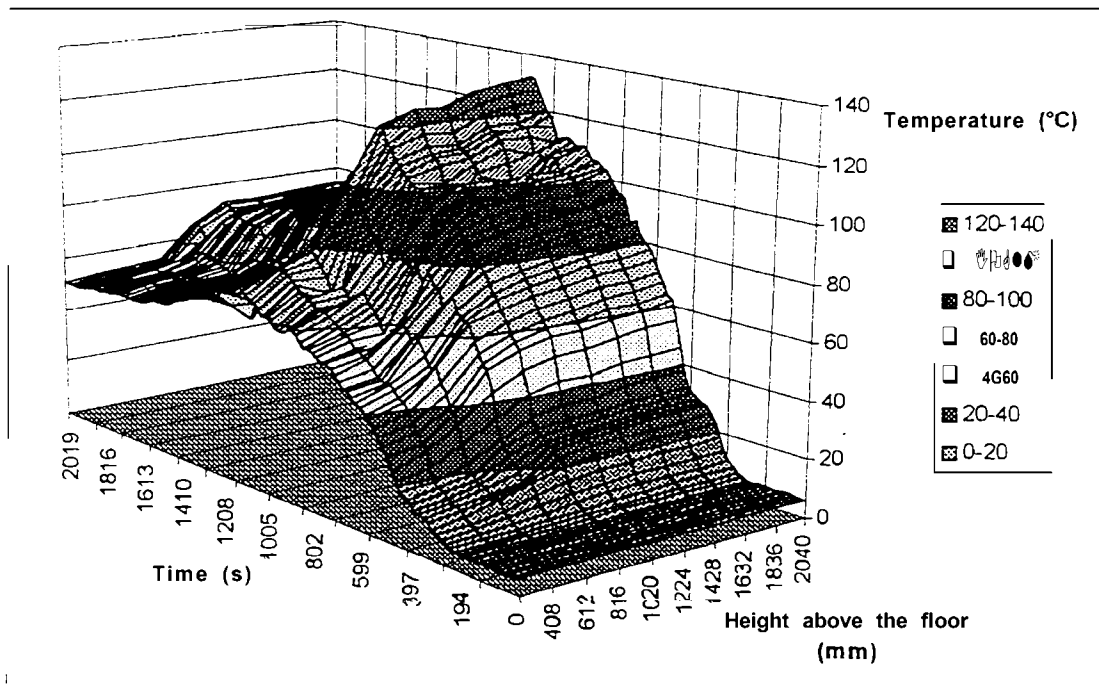

Figure FO7-24: Temperature distribution along the center line of Level 1M stairwell door

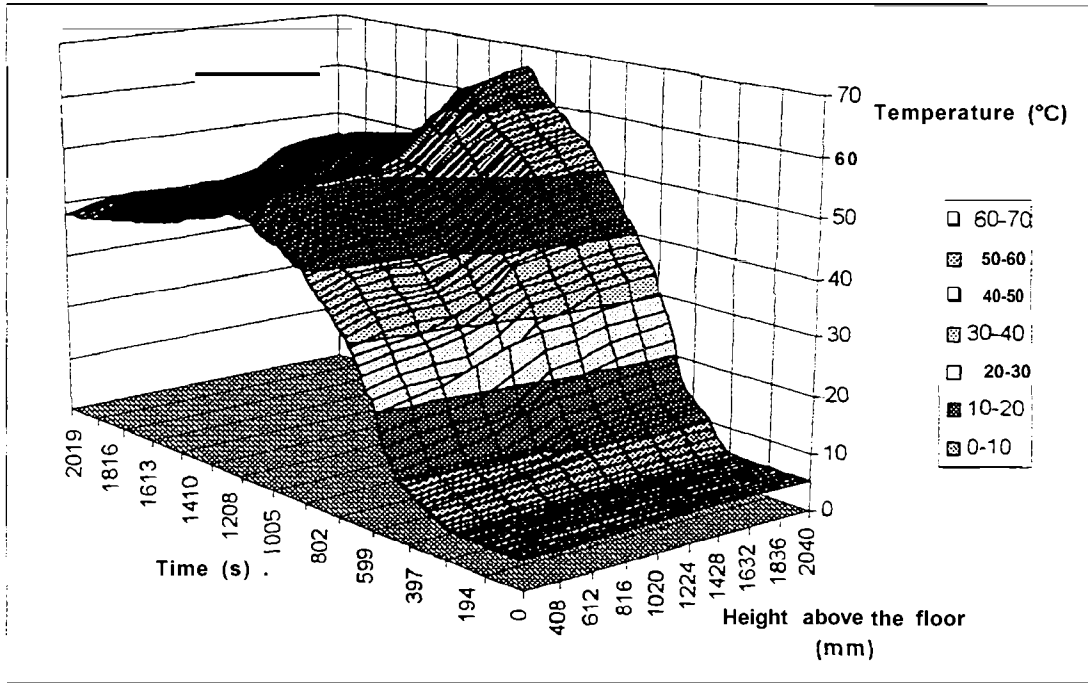

Figure FO7-25: Temperature distribution along the center line of Level 2 stairwell door

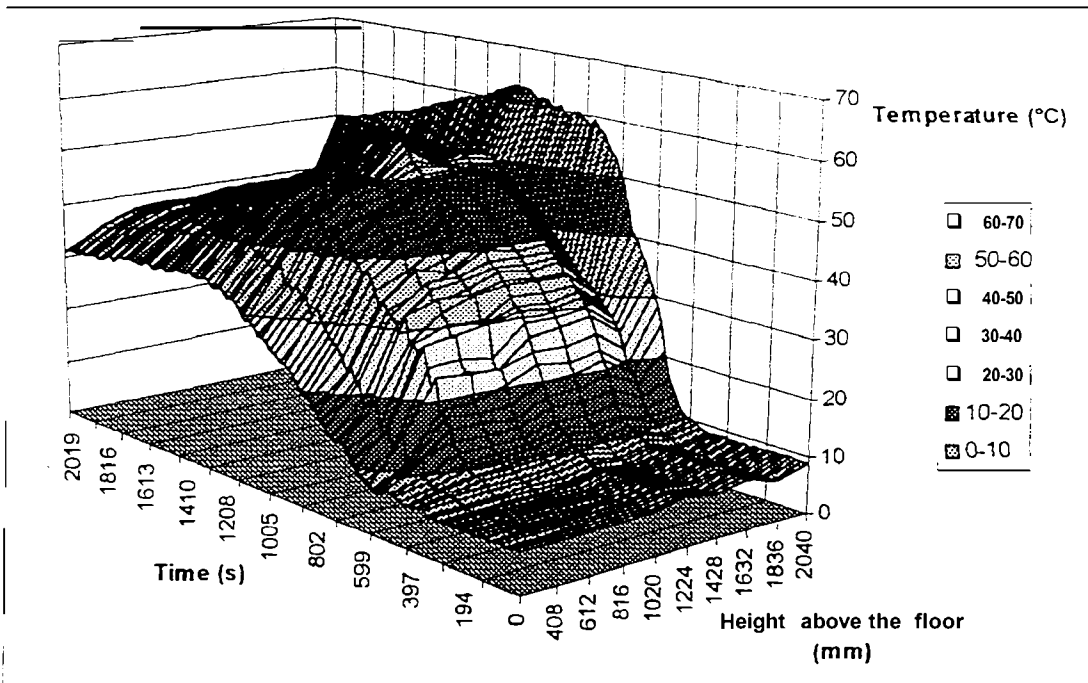

Figure FO7-26: Temperature distribution along the center line of Level 3 stairwell door

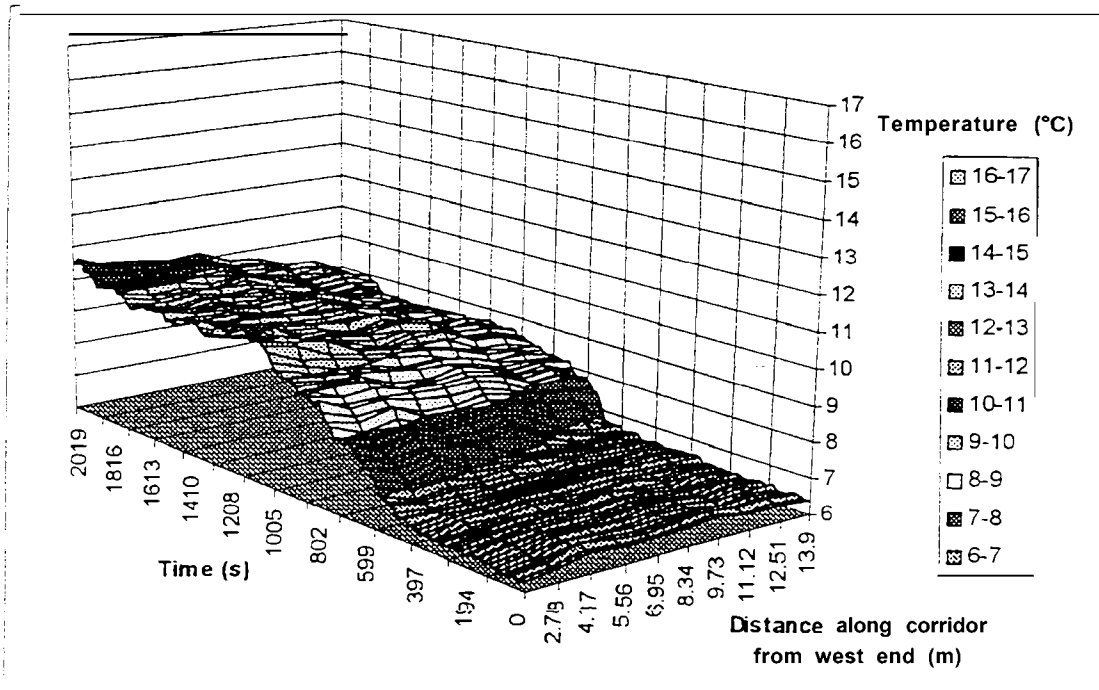

Figure FO7-27: Temperature distribution along Level IM corridor (1.7 m above the floor)

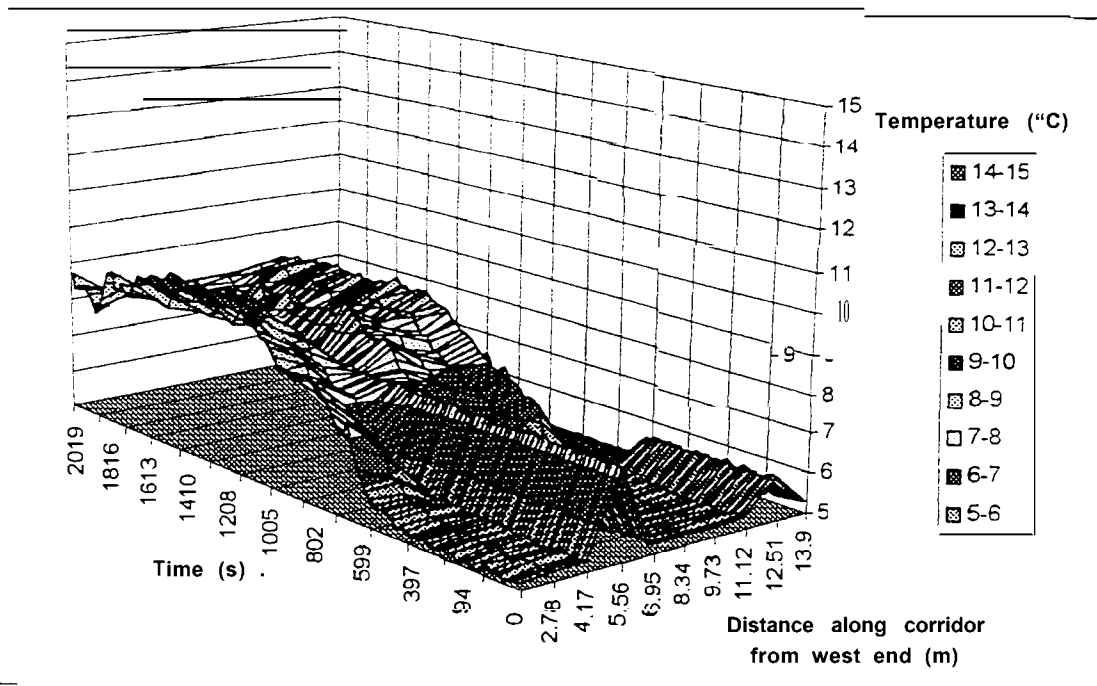

Figure FO7-28: Temperature distribution along Level 2 corridor (1.7 m above the floor)

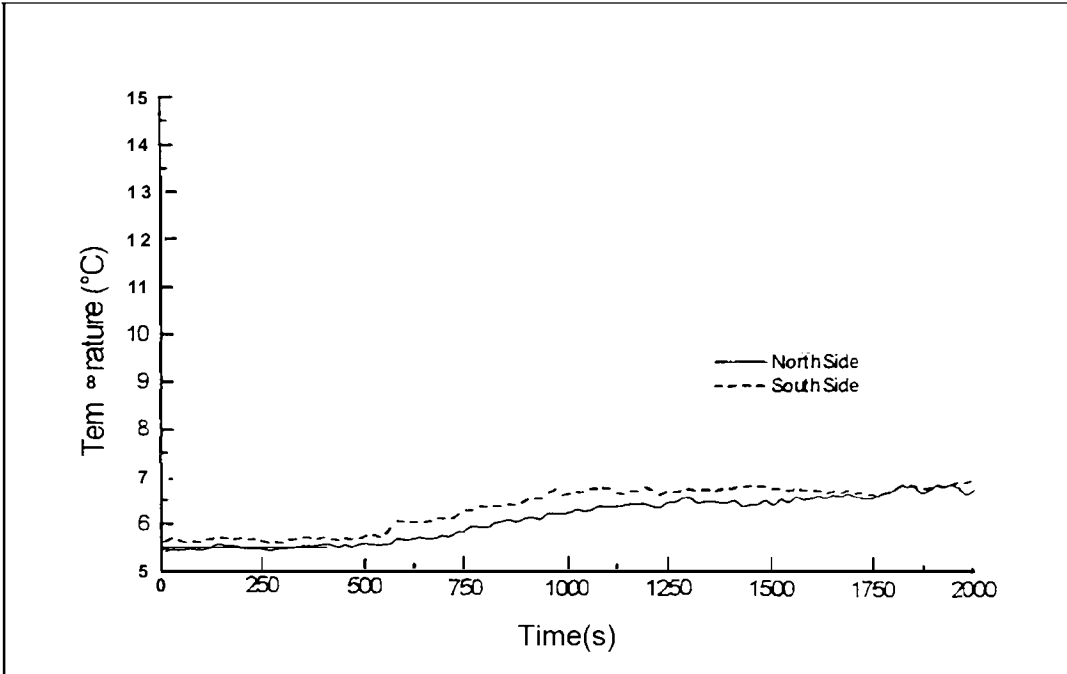

Figure FO7-29: Temperatures in Room 201 (1.7 m high)

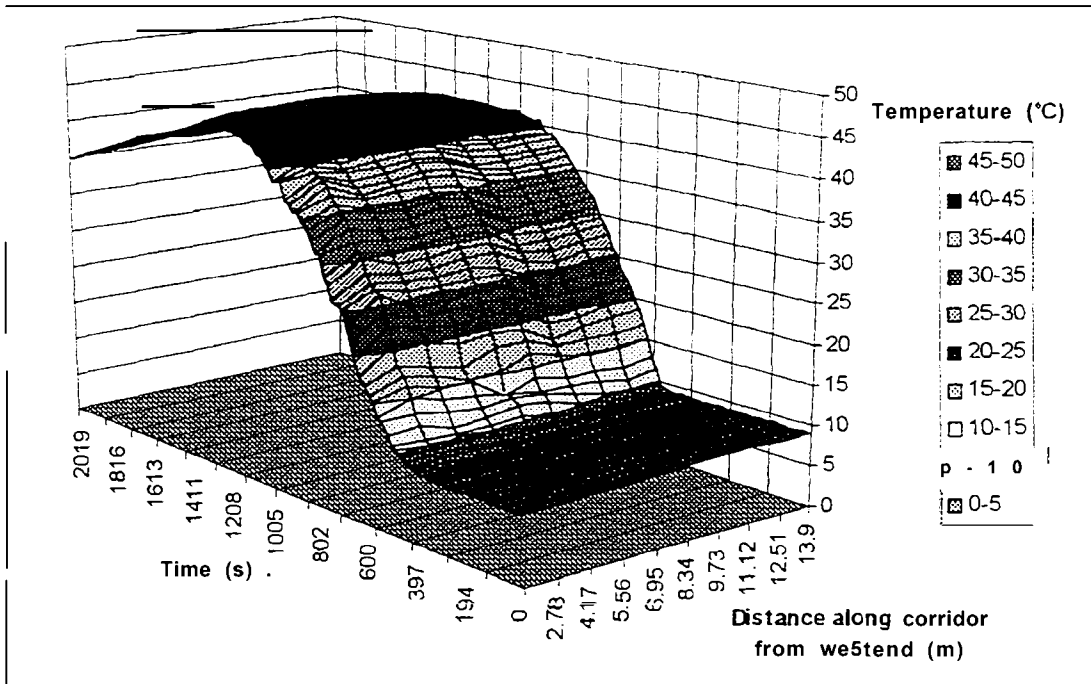

Figure FO7-30: Temperature distribution along Level 3 corridor (1.7 m above the floor)

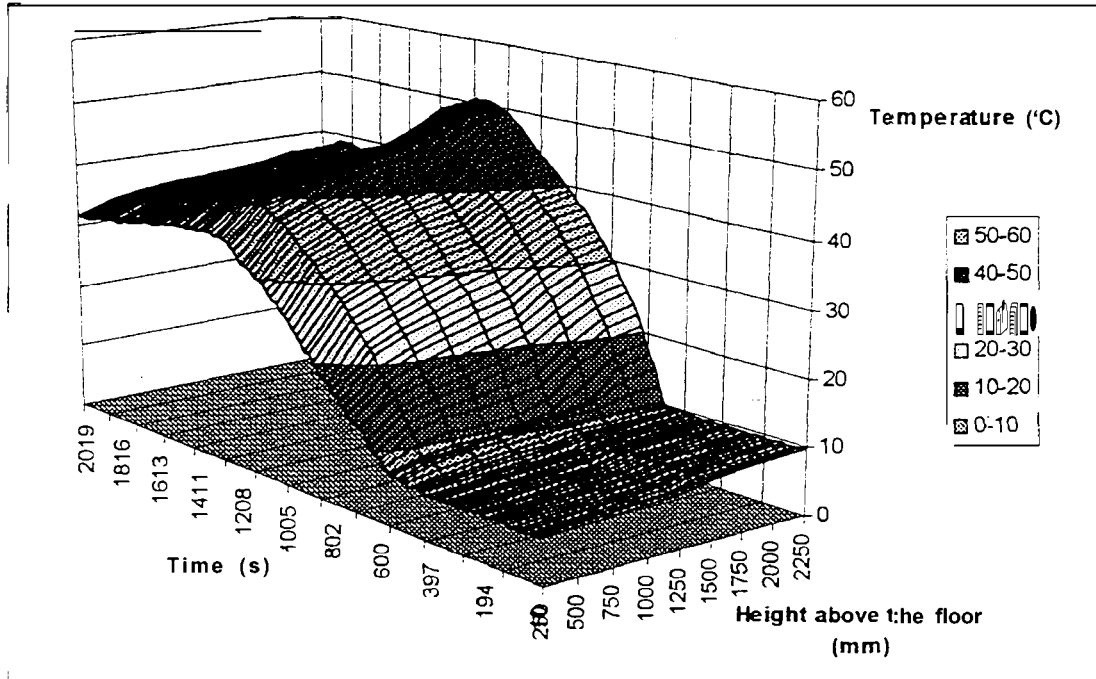

Figure FO7-3 1: Vertical temperature distribution in the center of Level 3 corridor

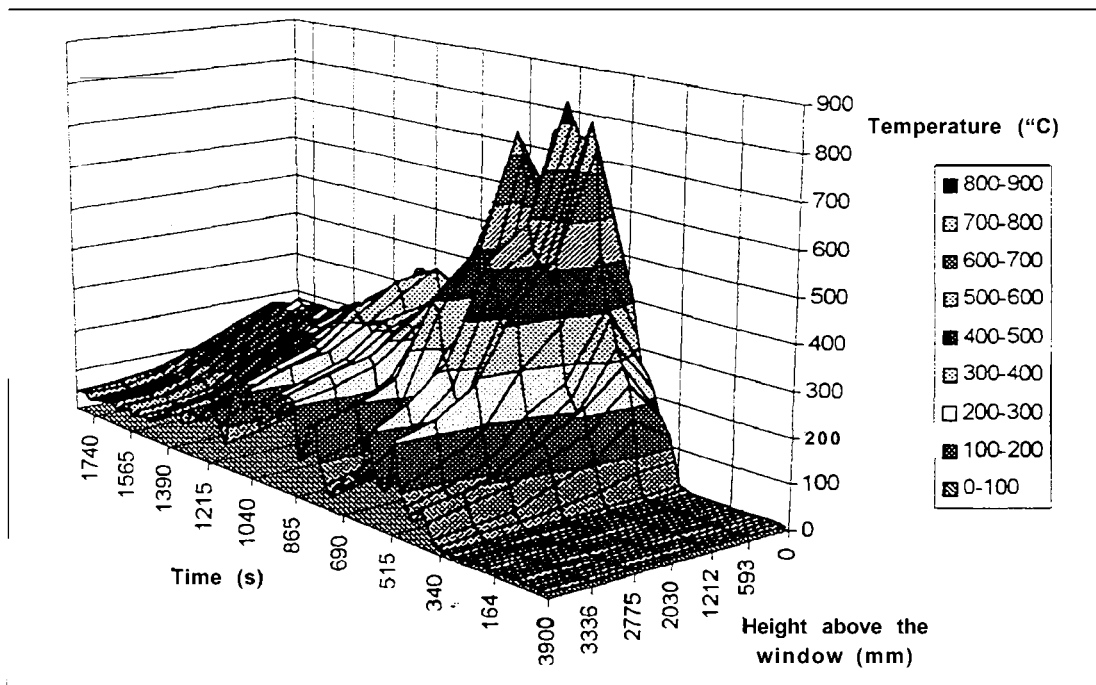

Figure FO7-32: External temperature along the center line of the bum room window (0.02 m from the wall)

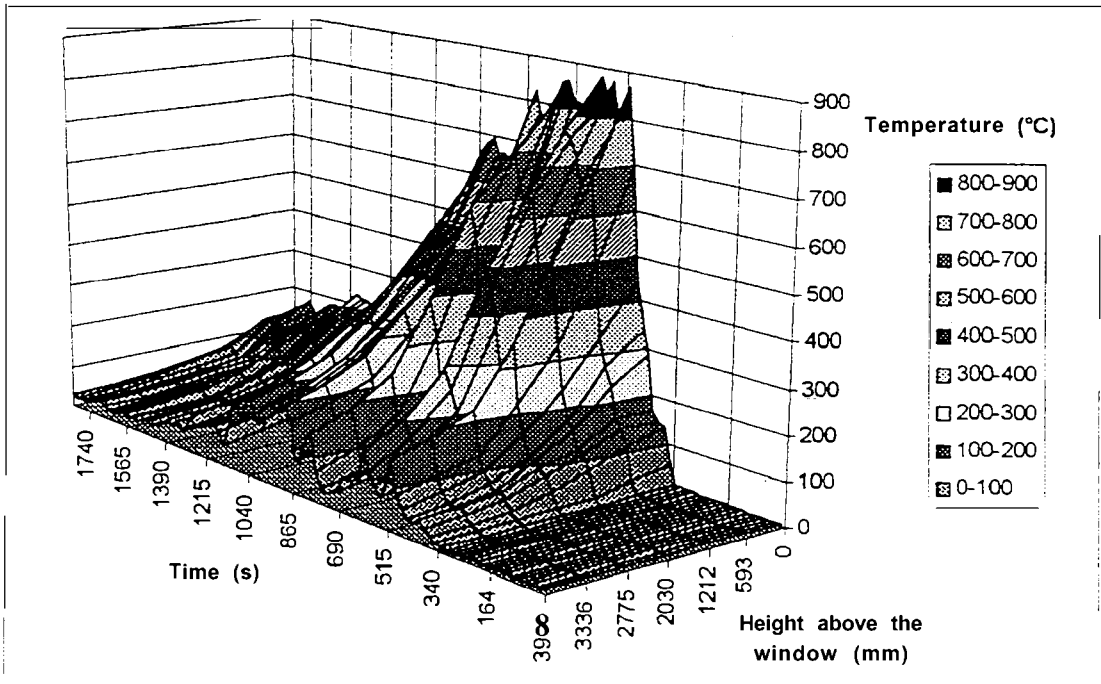

Figure FO7-33: External temperature along the center line of the bum room window (0.5 m from the wall)

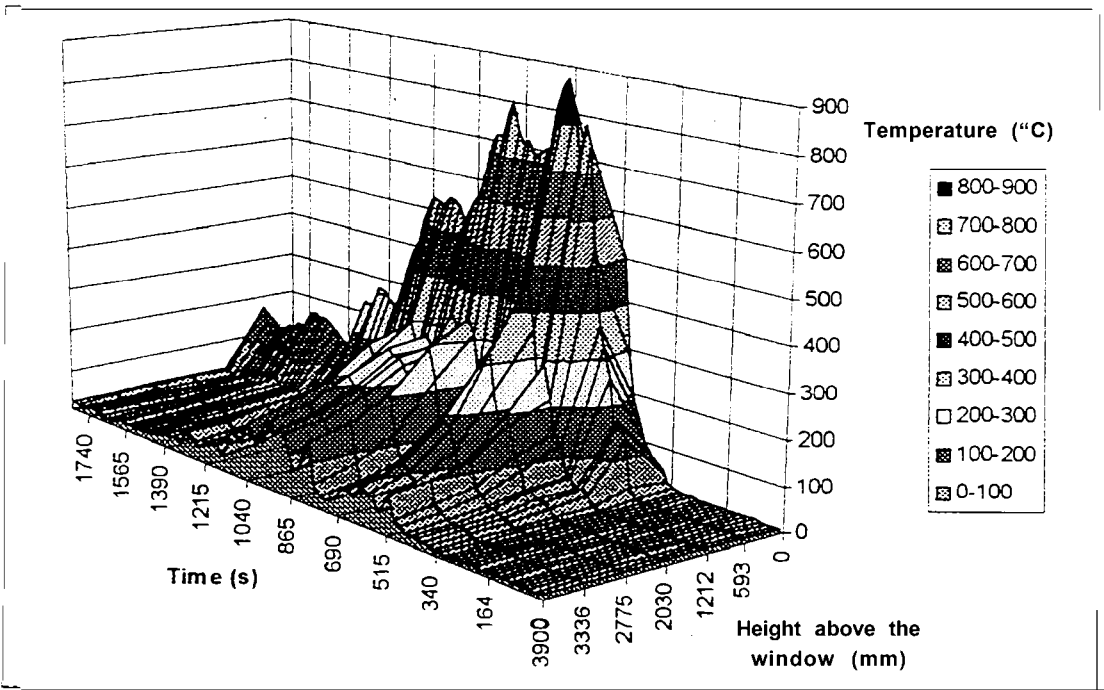

Figure FO7-34: External temperature along the center line of the bum room window (1.0 m from the wall)

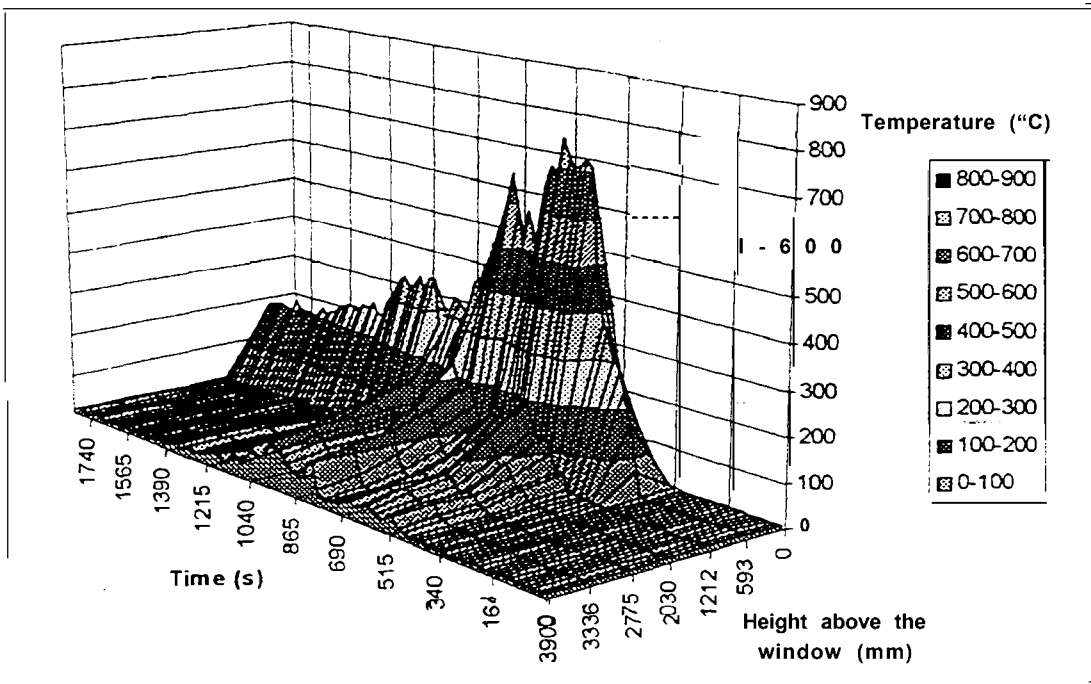

Figure FO7-35: External temperature along the center line of the bum room window (1.5 m from the wall)

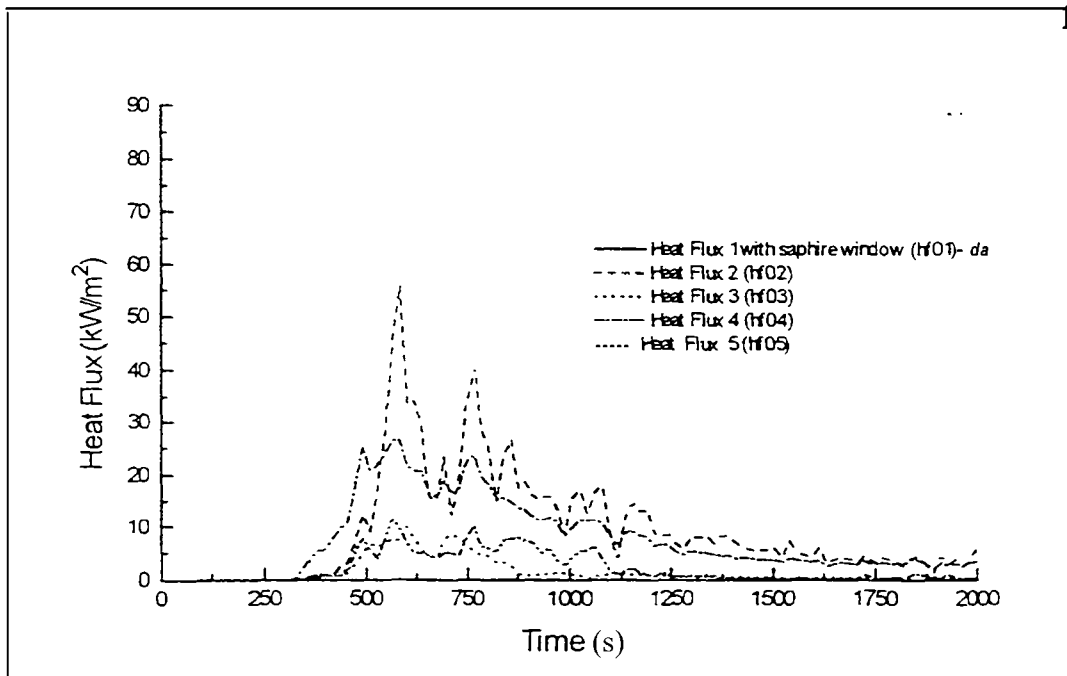

Figure FO7-36: External heat flux measurements (Refer to Figure 25 for locations)



## 16. Flashover Test FOS

**Test Conditions:**     **Bum Room Door Open**  
                               **Level 1 Stairwell Door Open**  
                               **Level 1 Sprinklers charged with water**

### Observations:

0:00 Ignition  
 00:33 Ionisation detector (no cap) activated  
 2:55 Smoke layer reaching to the top of the window (0.4 m from ceiling)  
 3:30 Significant bowing of the window  
 4:20 Initial cracking of middle pane  
 4:25 Sprinkler above the small platform activated - water discharged  
       *Does not appear to be controlling the fire*  
       Smoke layer to the top of the couch (1.45 m from ceiling)  
 5:40 Fire actual increases in strength  
       Room full of thick smoke  
 6:20 Sprinkler above the large platform activated - water discharged  
 6:30 More cracking of middle pane  
       *Fire starting to be controlled*  
 8:30 Very little flaming- couch still smouldering  
  
 9:00 Smoke begins to enter Level 3 corridor  
 10:00 Smoke thickening  
 16:00 Level 3 corridor full of smoke

The center third of the couch was completely consumed by the fire and the inside of the seats on either side of the center were hollow even though the surface remained intact. Other than the carpet beneath the couch no other fuel load was affected by the fire before the sprinklers began to control it. The P/U and the carpet in Level I corridor were unaffected by the fire.

**Table 14: Summary of results for Test FO8**

<b>In the Burn Room</b>	
Maximum Heat Release Rate	na MW
Maximum Peak Temperature	265 °C
Maximum Average Room Temperature	68°C
Minimum Oxygen Concentration	15.8 Vol %
Maximum Total Heat Flux	2 kW/m <sup>2</sup>
Time untenability reached (1 00°C)	T<100 °C

<b>At the Bum Room Door</b>		
Maximum CO Concentration a		0.4 Vol %
Maximum CO <sub>2</sub> Concentration		4 Vol %
Maximum Temperature		150 °C
Minimum Oxygen Concentration		13 Vol %
<b>In Level 1 Corridor</b>		
Maximum Temperature 1.5 m above the floor		69 °C
Maximum Temperature in the center of the Corridor		88 °C
<b>Stairwell</b>		
Maximum Temperature	Level 1	22 °C
	Level 1M	22 °C
	Level 2	15 °C
	Level 3	15 °C
<b>Level 3 Corridor</b>		
Maximum Temperature		15 °C
<b>External</b>		
Maximum External Temperature		na °C
Maximum Total Heat Flux		0 kW/m <sup>2</sup>

Note: A full list of detector and sprinkler activation times is shown in Table 15 & 16. Only the time for the first detector activated is listed in the above observations.

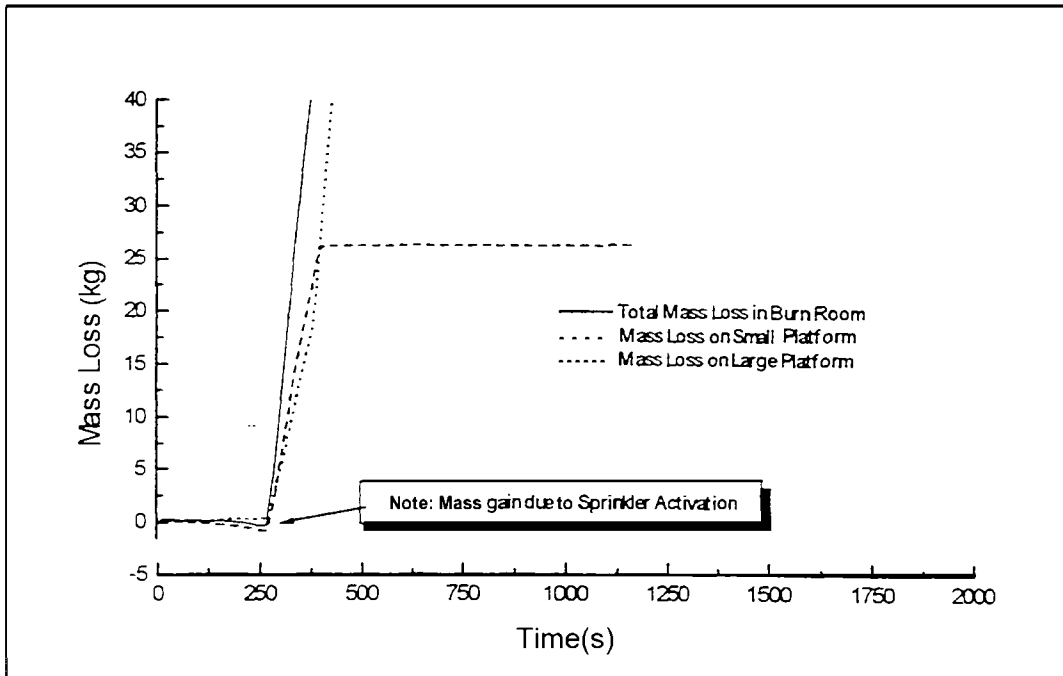

Figure FO8-1: Combined mass loss in the burn room

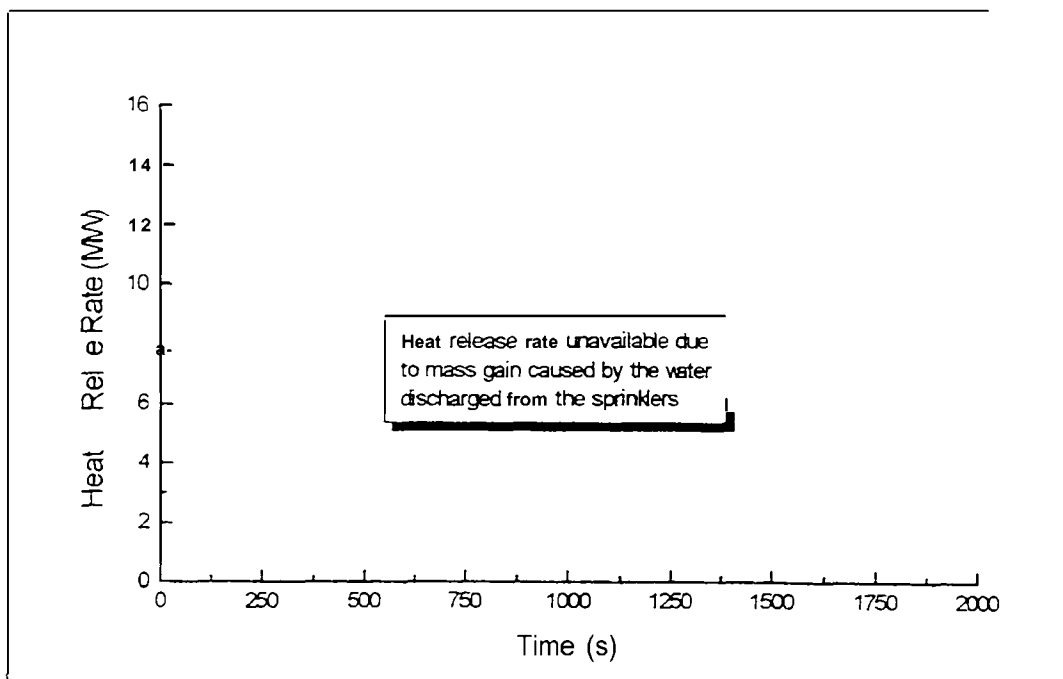

Figure FOS-2: Total heat release rate in the burn room

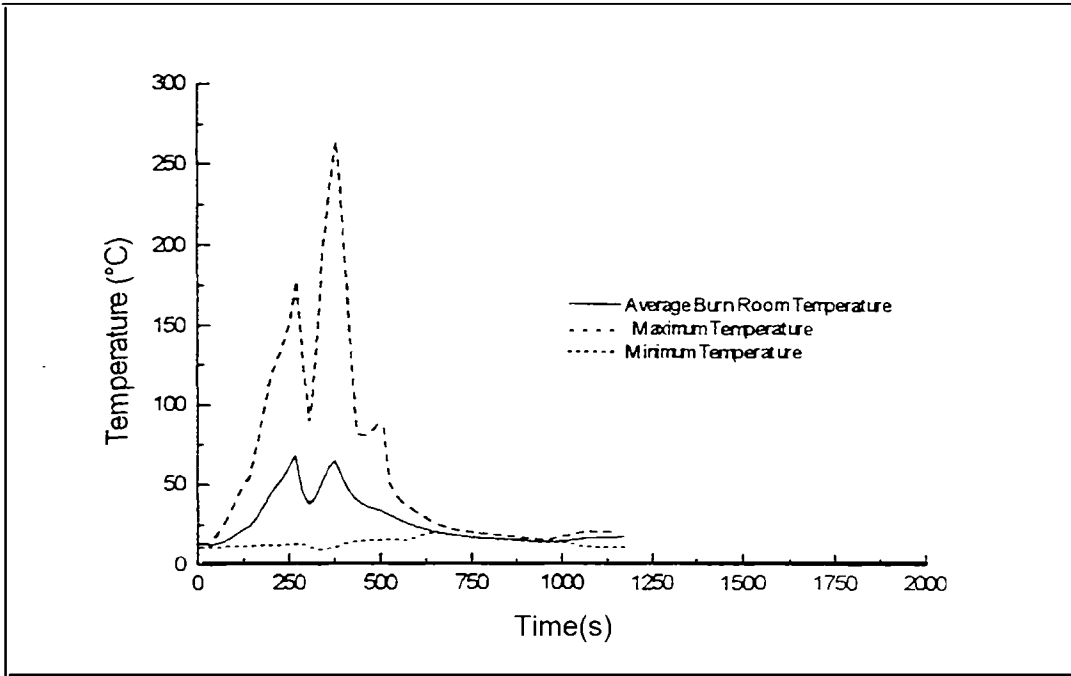

Figure FO8-3: Average, maximum and minimum temperatures in the burn room

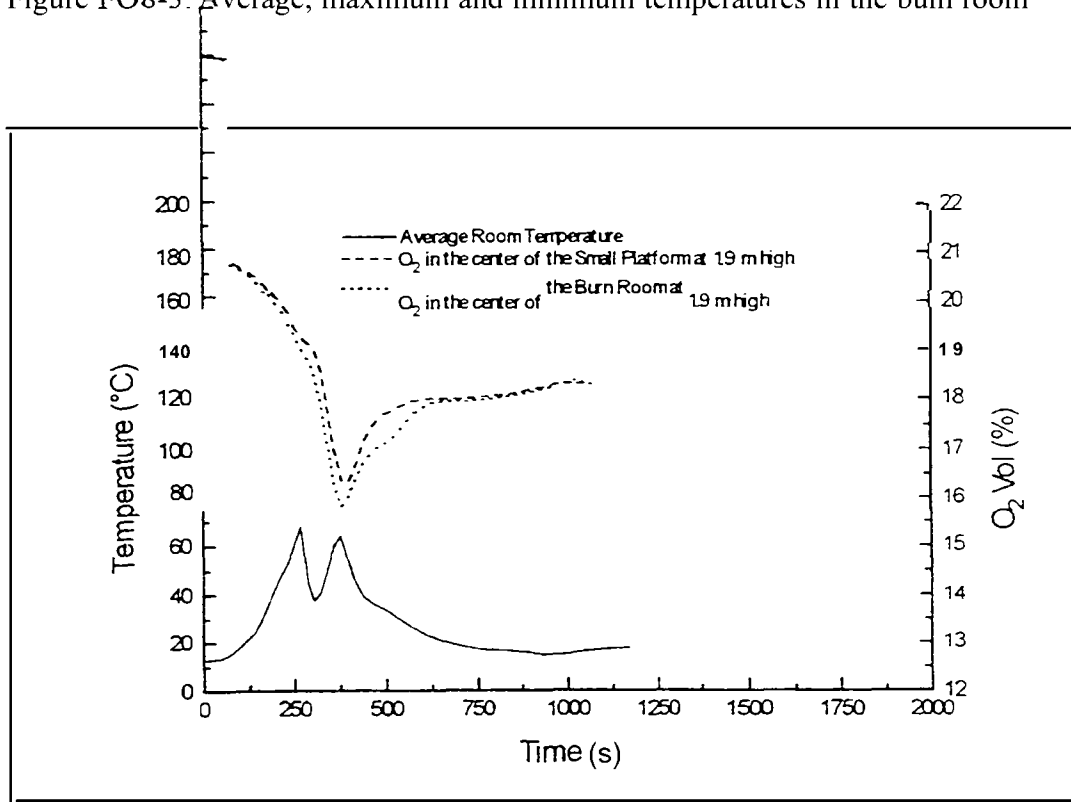

Figure FO8-4: Oxygen concentration and average temperature in the burn room

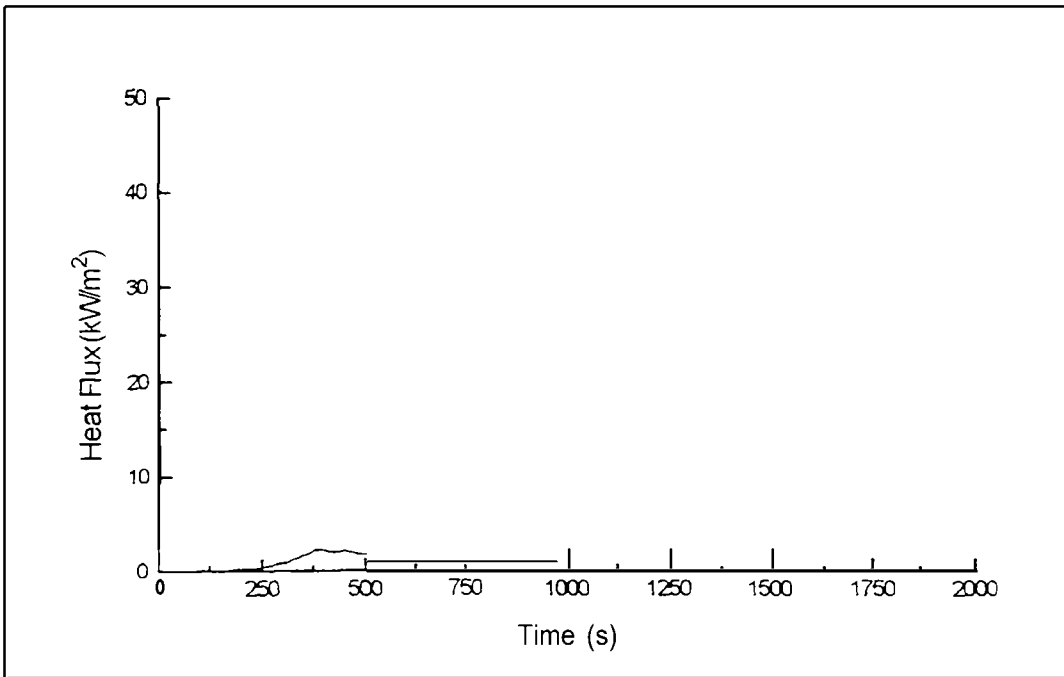

Figure FO8-5: Total heat flux in the center of the bum room

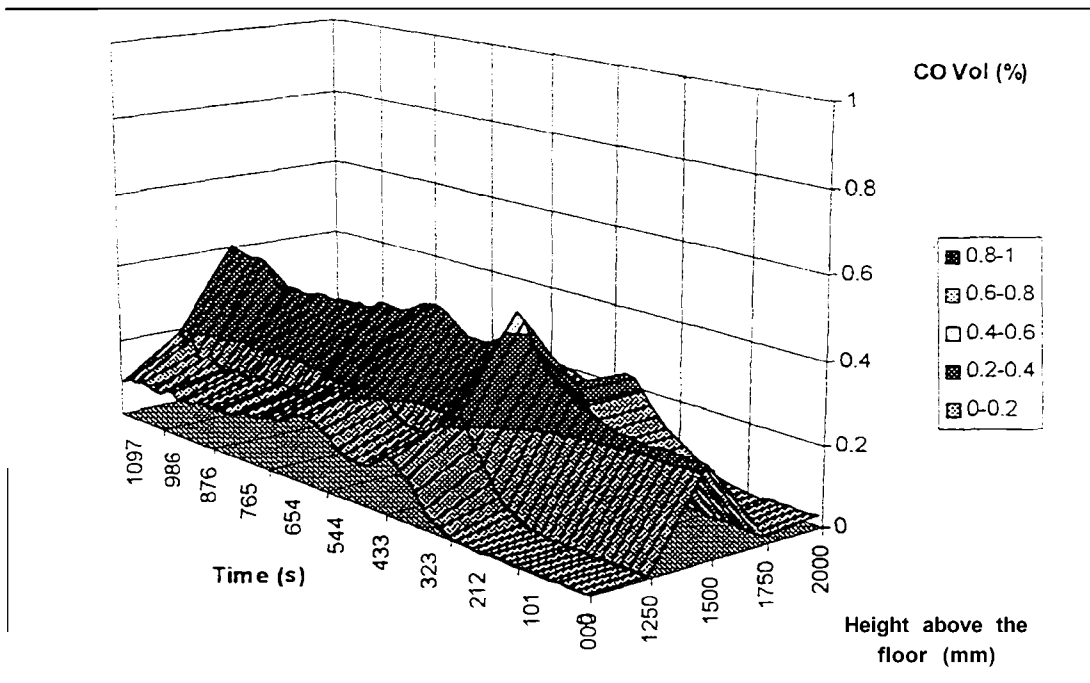

Figure FO8-6: Carbon monoxide concentration along the center line of the bum room door

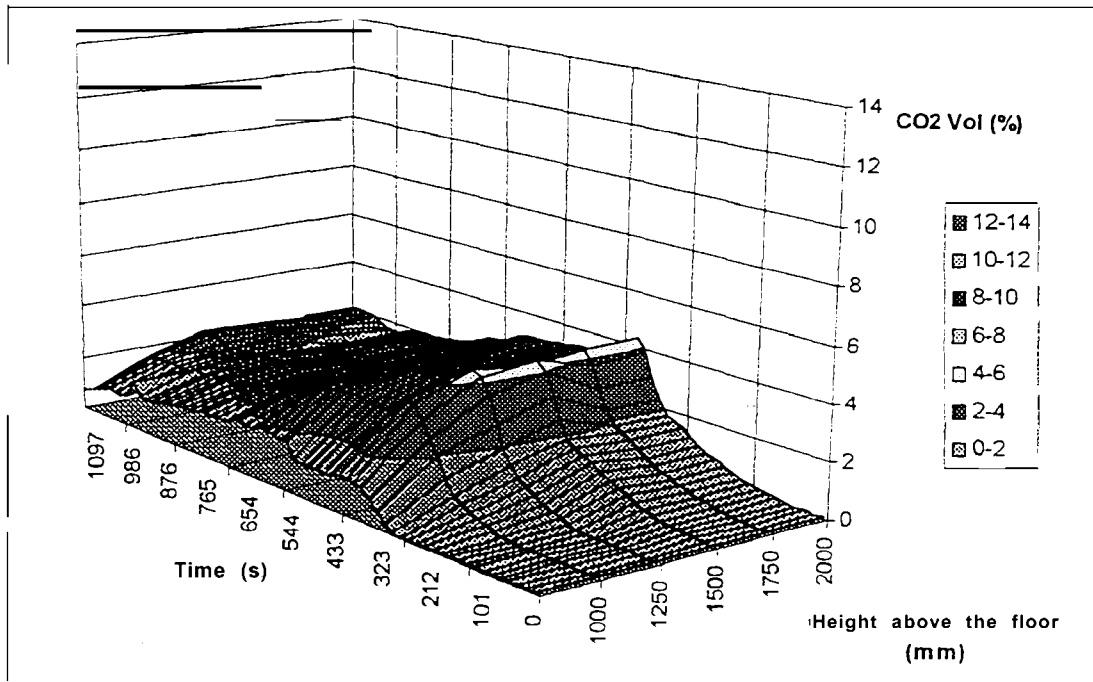

Figure FO8-7: Carbon dioxide concentrations along the center line of the burn room door

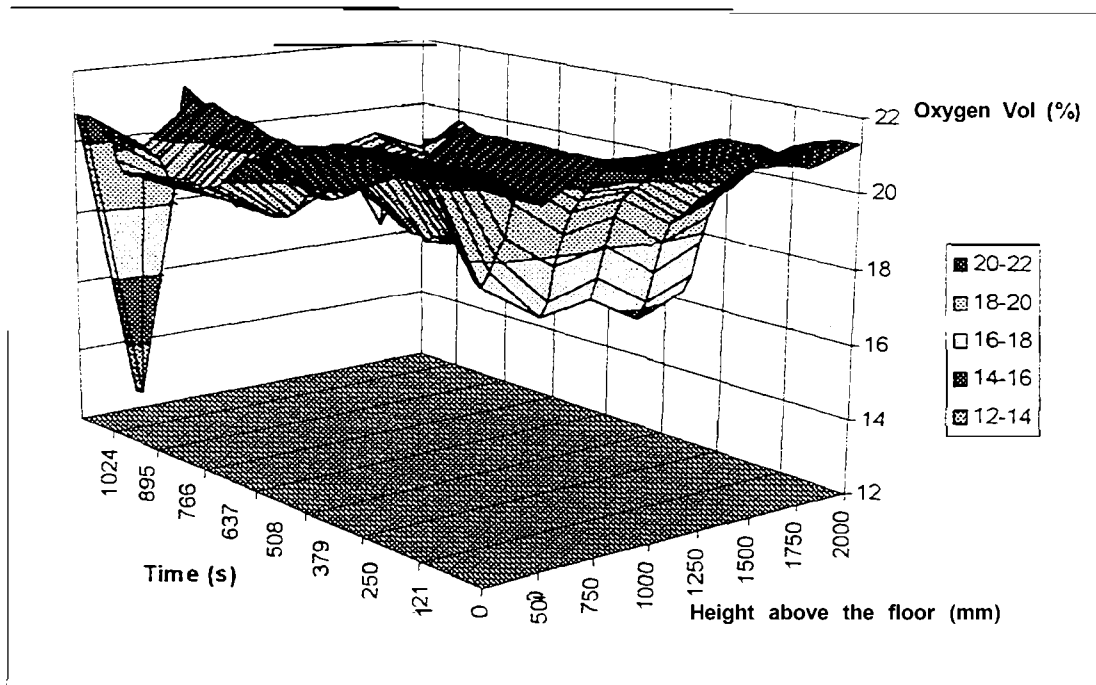

Figure FO8-8: Oxygen concentrations along the center line of the burn room door

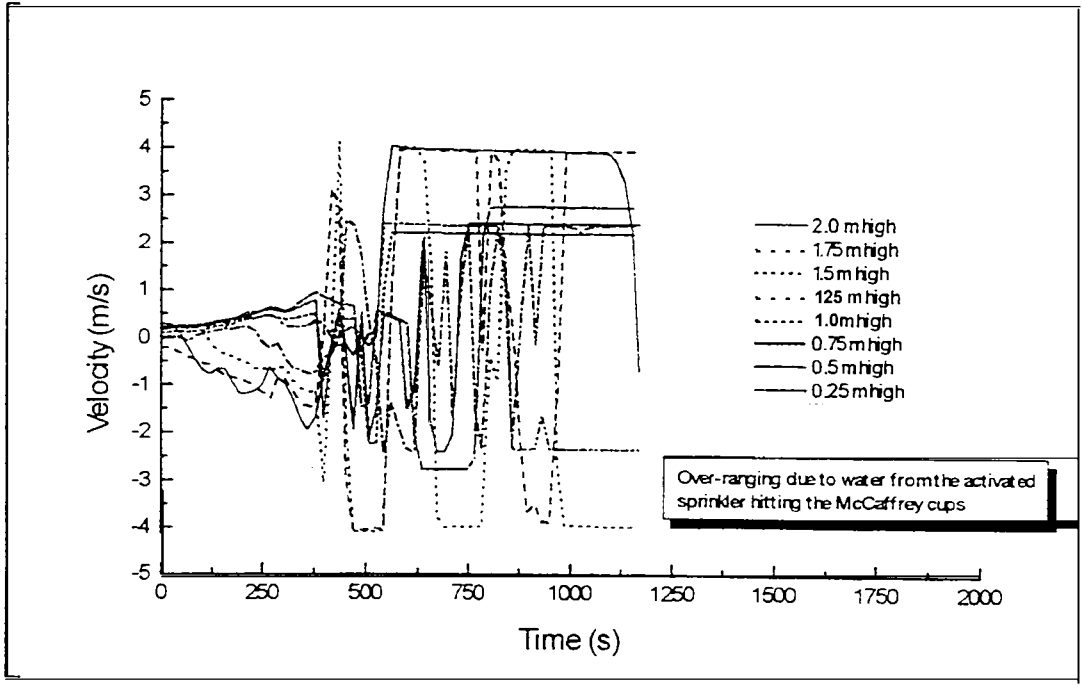

Figure FO8-9: Flow velocity distribution at the center line of the bum room door

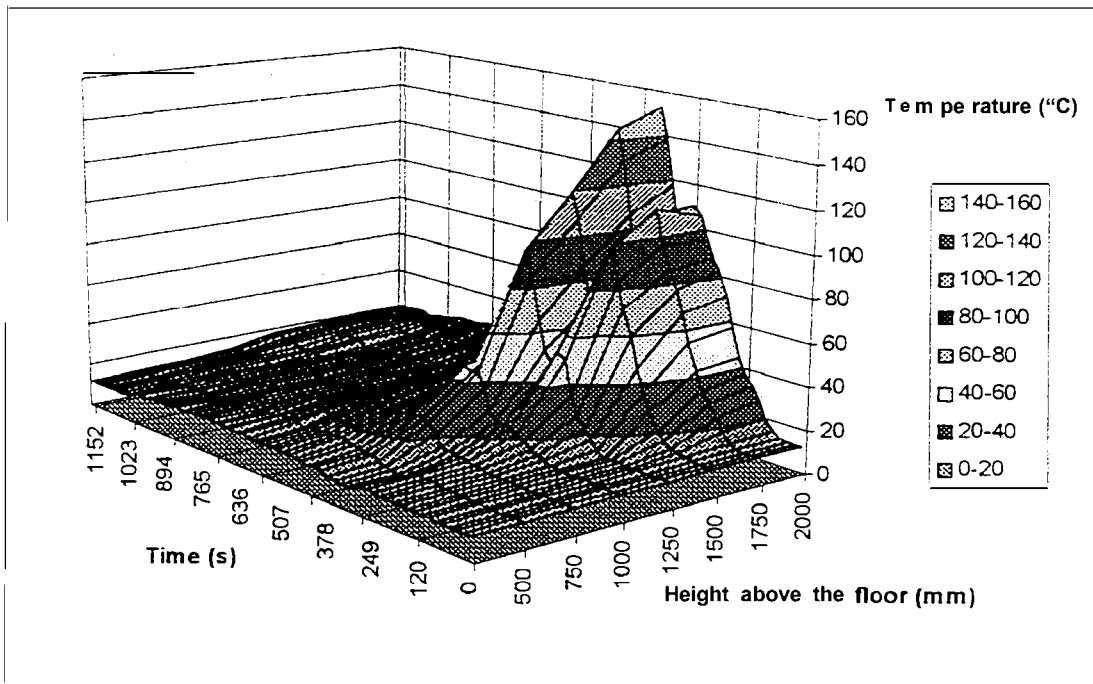

Figure FO8-10: Temperature distribution along the center line of the bum room door

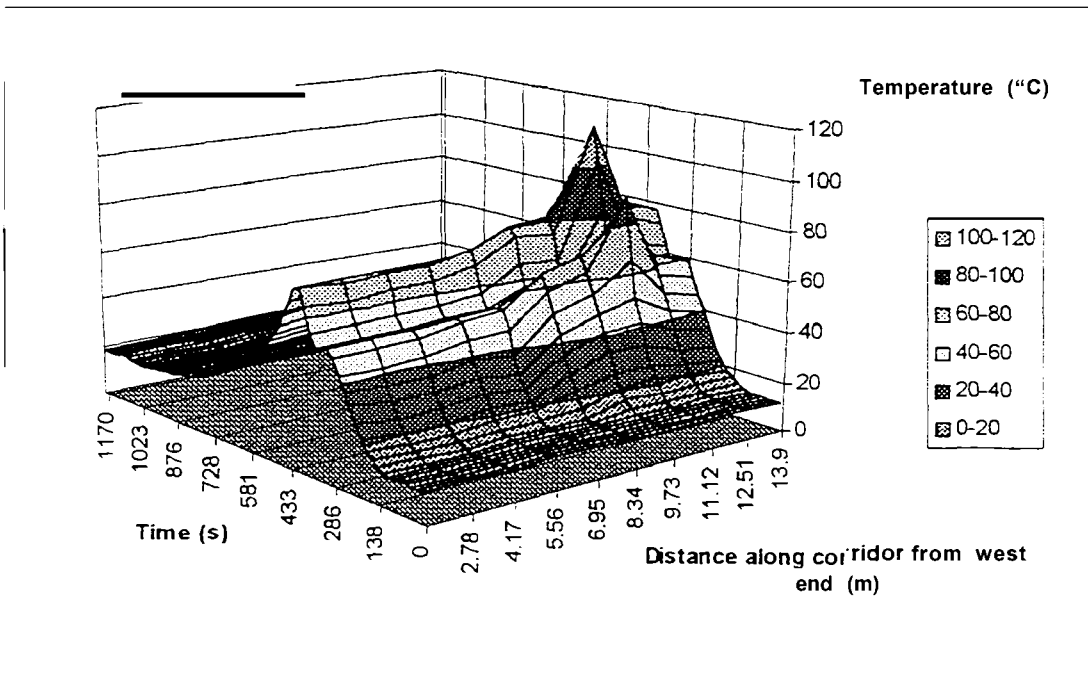

Figure FO8-11: Temperature along Level 1 corridor (2.0 m above the floor)

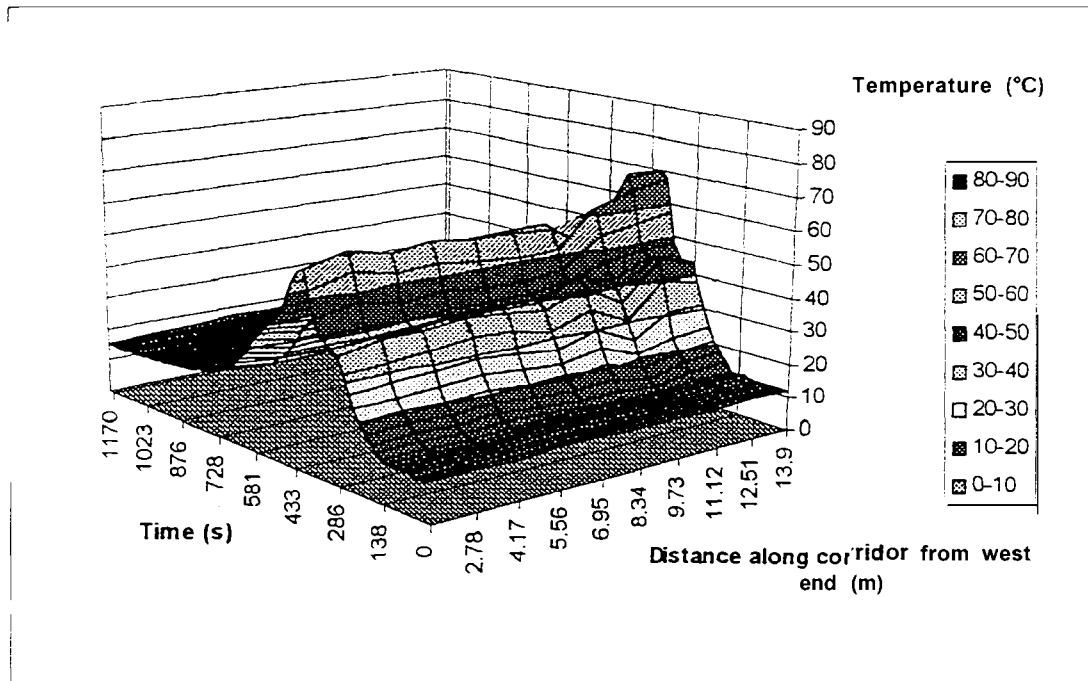

Figure FO8-12: Temperature along Level 1 corridor (1.5 m above the floor)



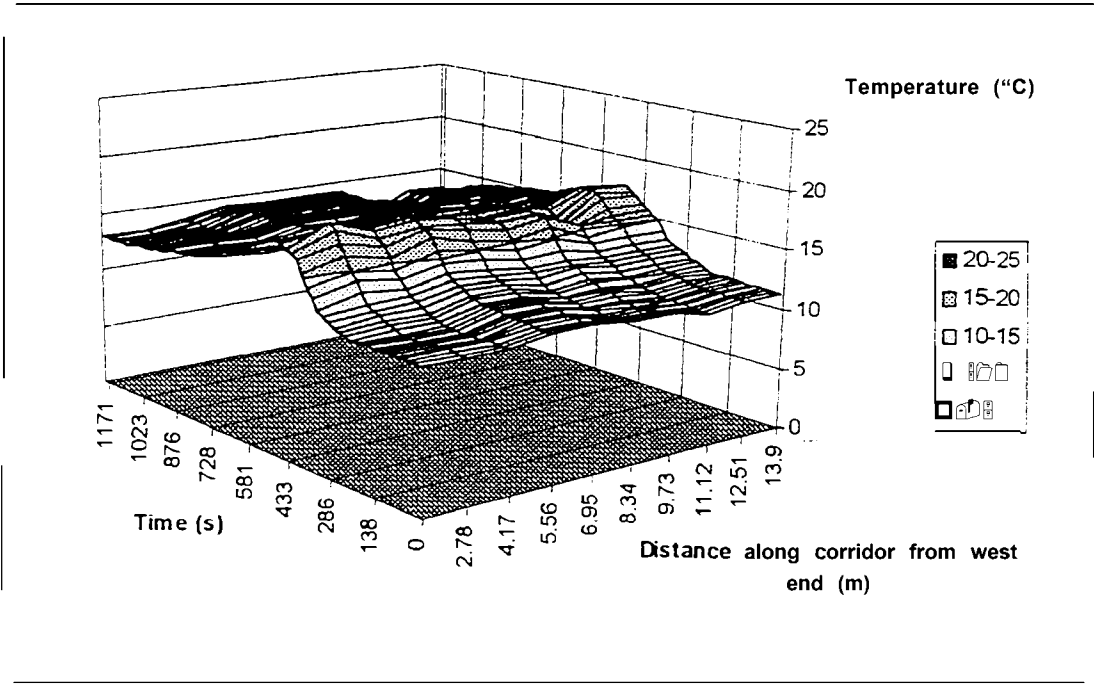

Figure FO8-13: Temperature along Level 1 corridor (0.5 m above the floor)

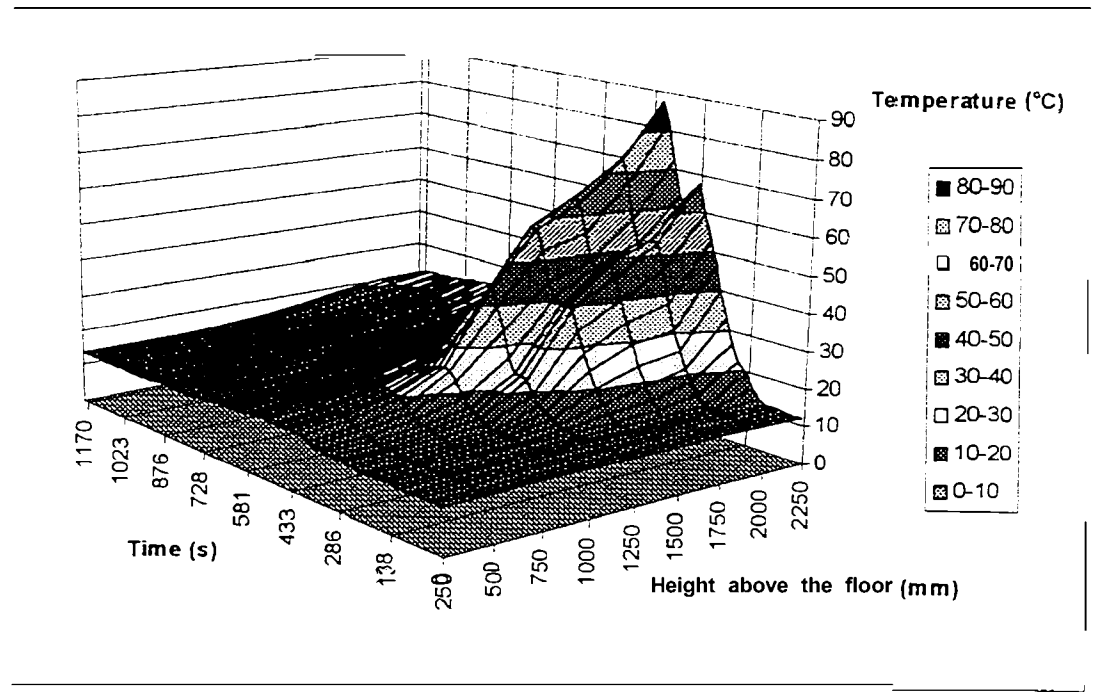

Figure FO8-14: Vertical temperature distribution in the center of Level 1 corridor

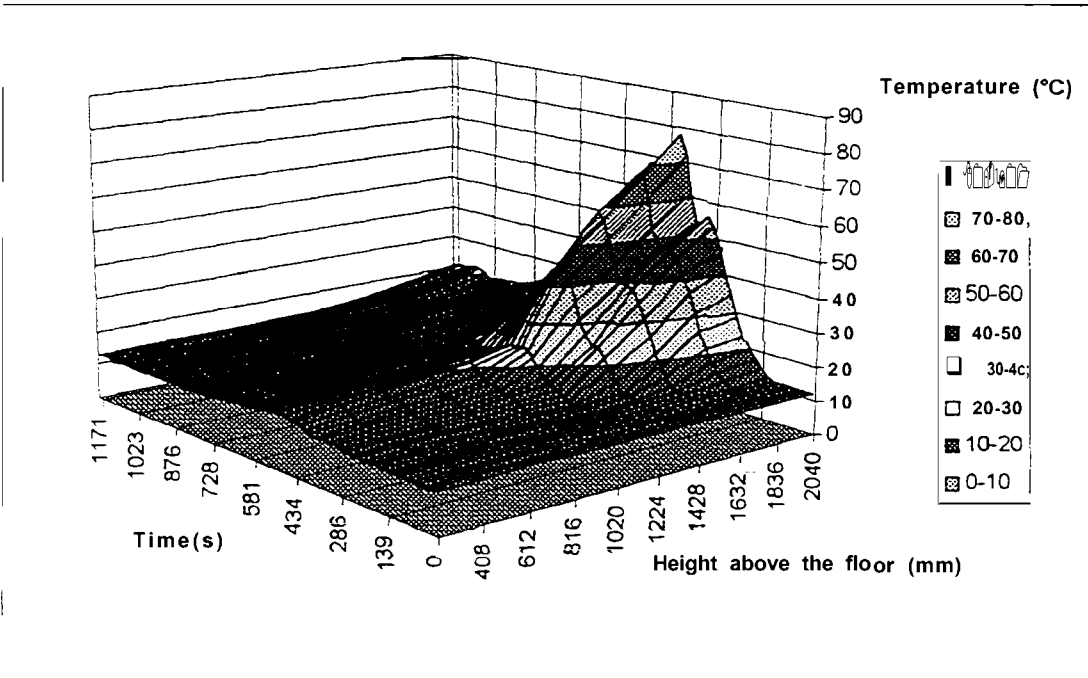

Figure FO8-15: Temperature distribution along the center line of Level 1 stairwell door

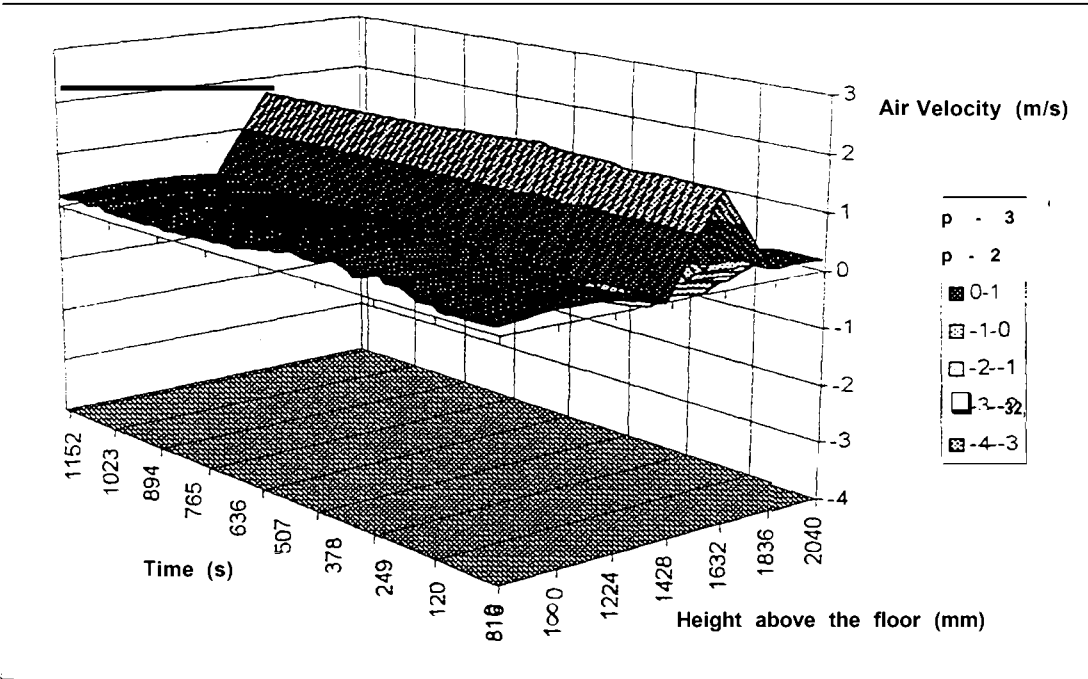

Figure FO8-16: Flow velocity distribution at the center line of Level 1 stairwell door

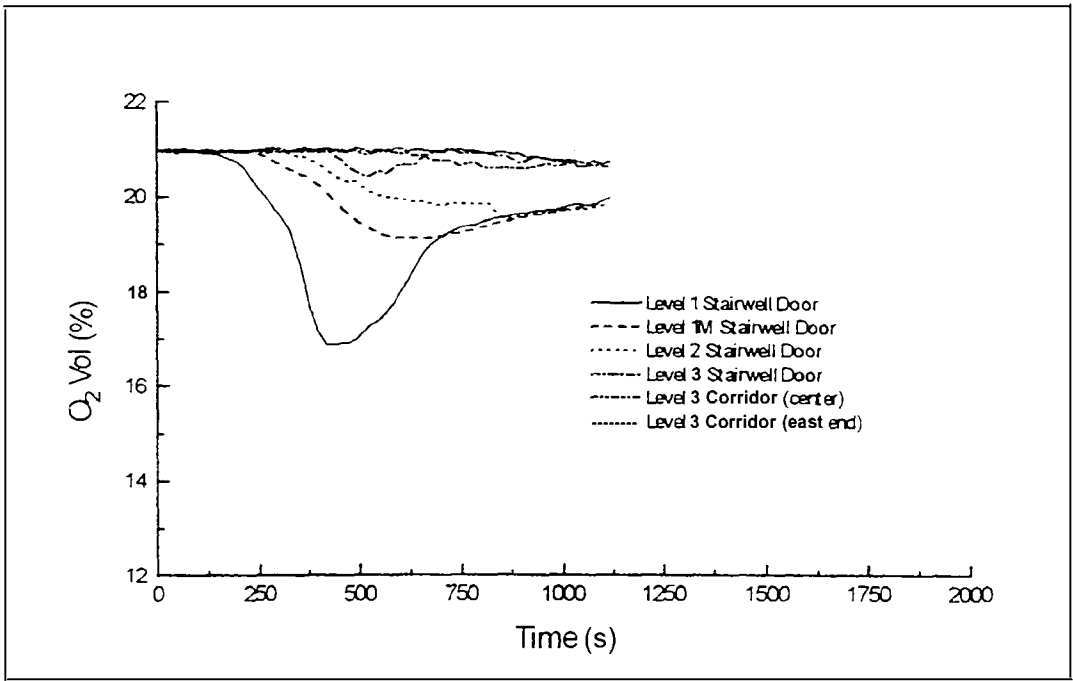

Figure FO8-17: Oxygen concentration at the stairwell doors ( 1.7 m above the floor)

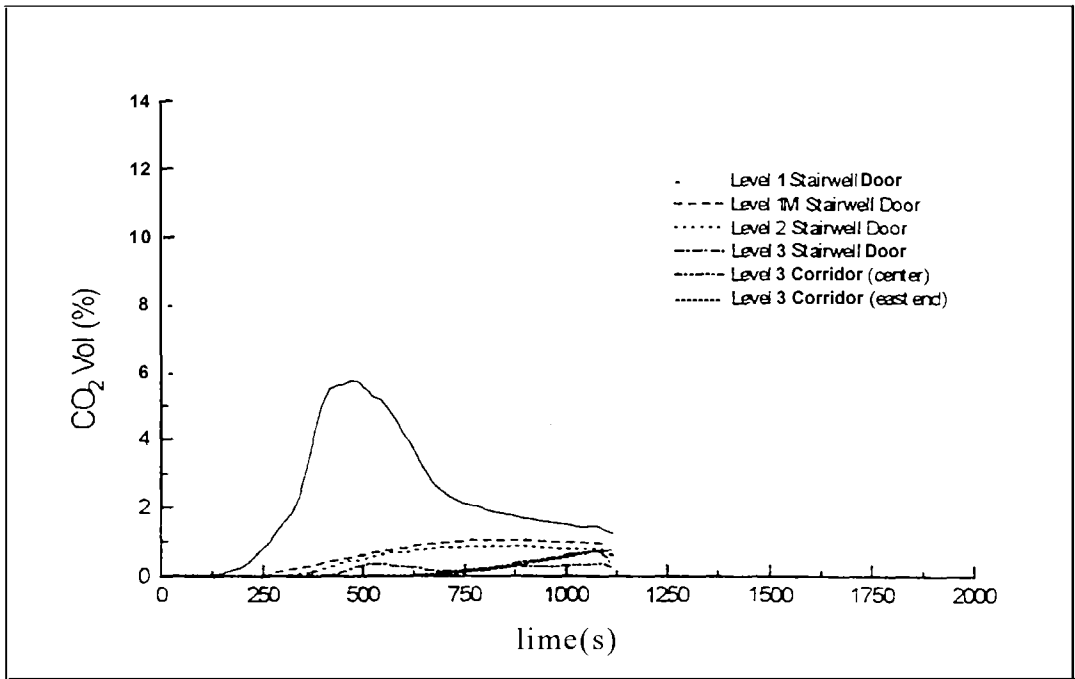

Figure FO8-18: Carbon dioxide concentration at the stairwell doors ( 1.7 m above the floor)

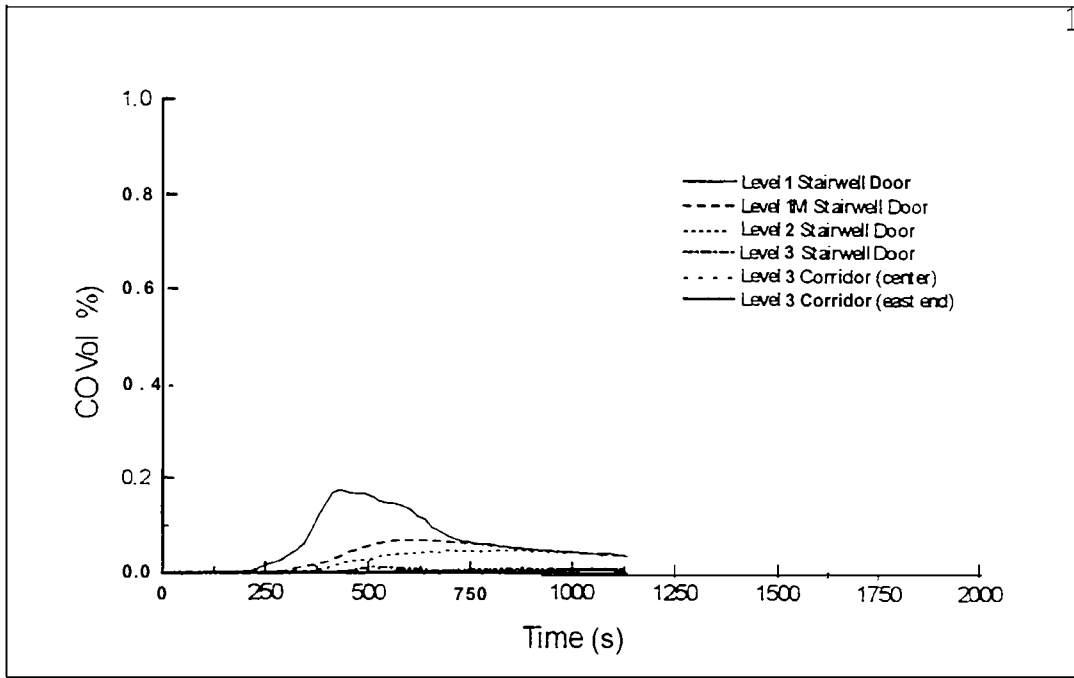

Figure FO8-19: Carbon monoxide concentration at the stairwell doors (1.7 m above the floor)

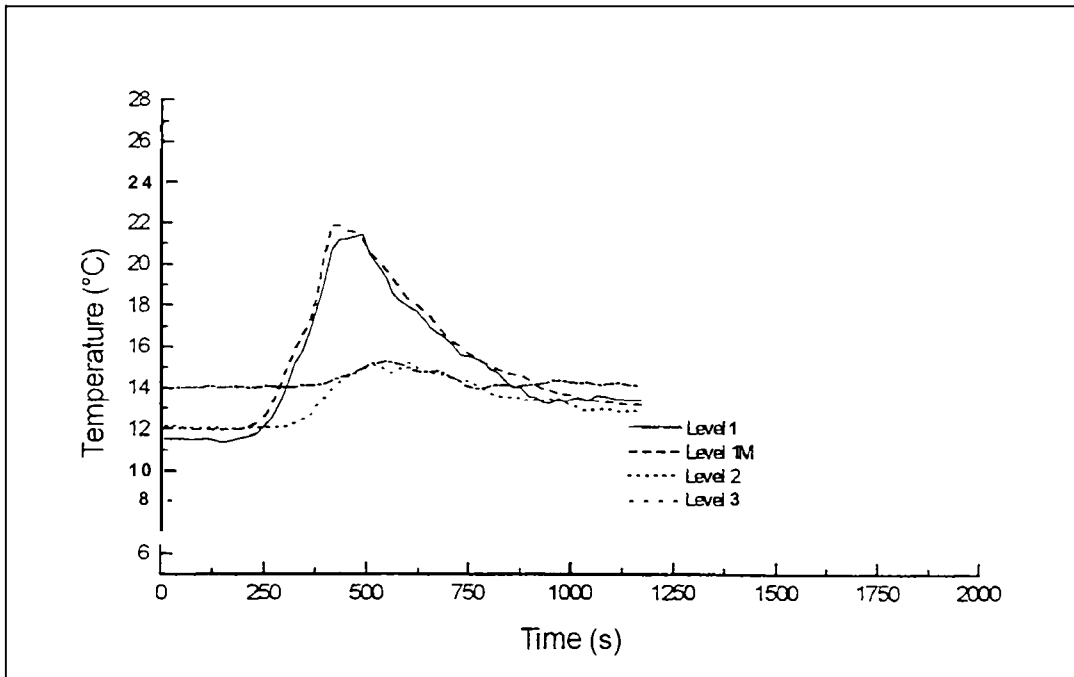

Figure FO8-20: Temperature in the stairwell at each level -North side (1.7 m above the floor)

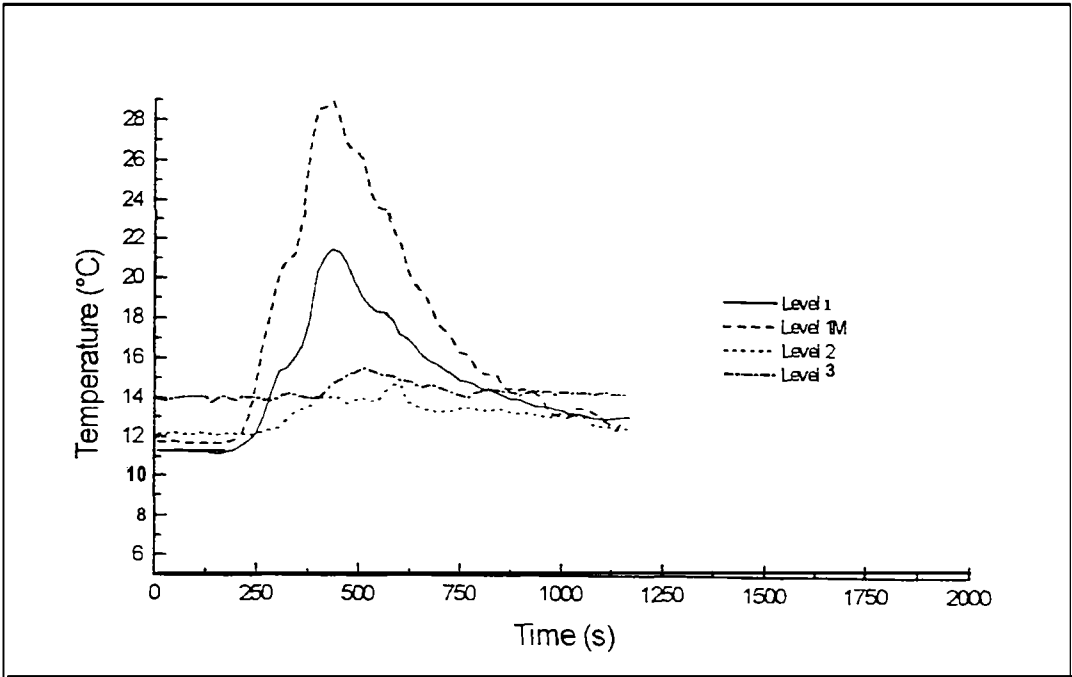

Figure FO8-21: Temperature in the stairwell at each level-South side (1.7 m above the floor)

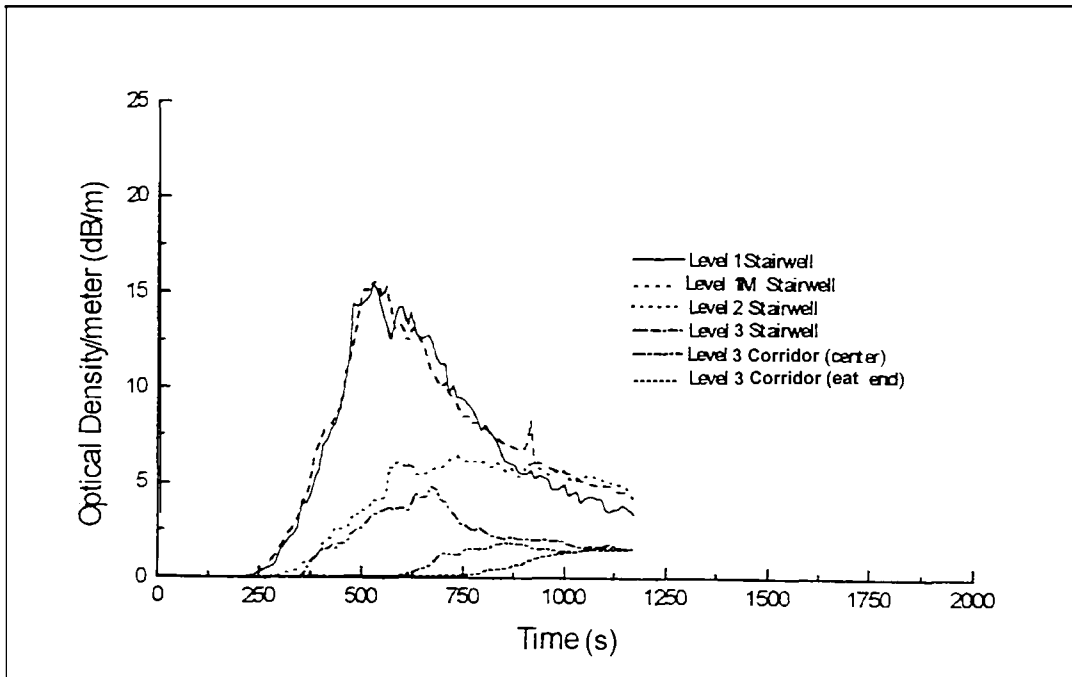

Figure FO8-22: Optical density/m at six locations (1.7 m above the floor)

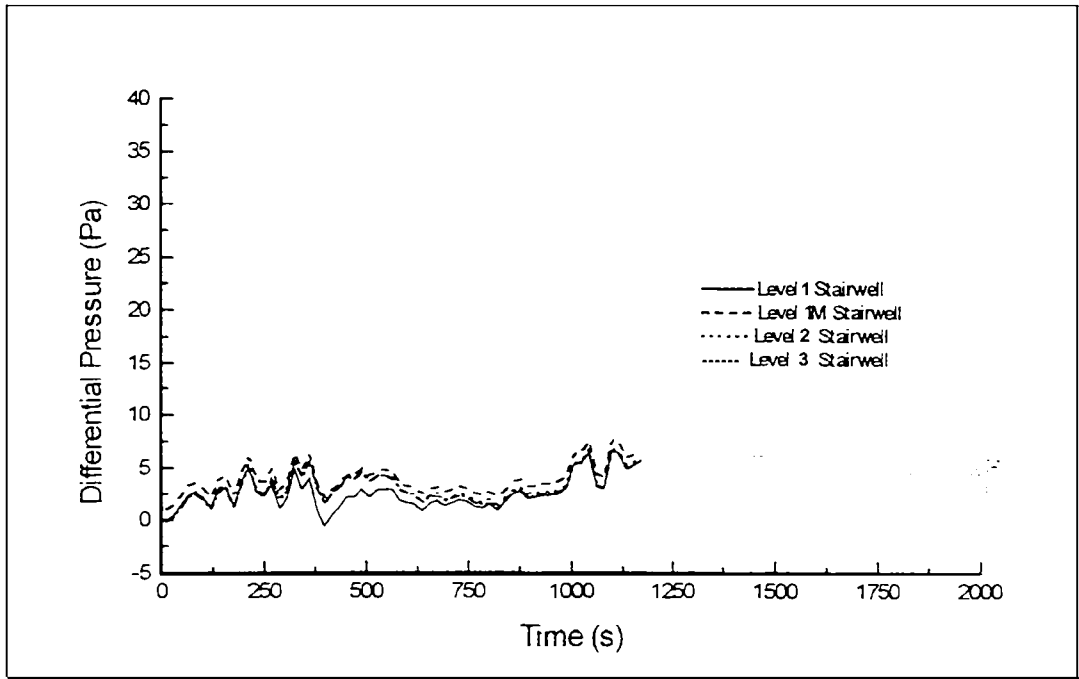

Figure FO8-23 : Pressure differences between outside and the stairwell at each level (1.7 m above the floor)

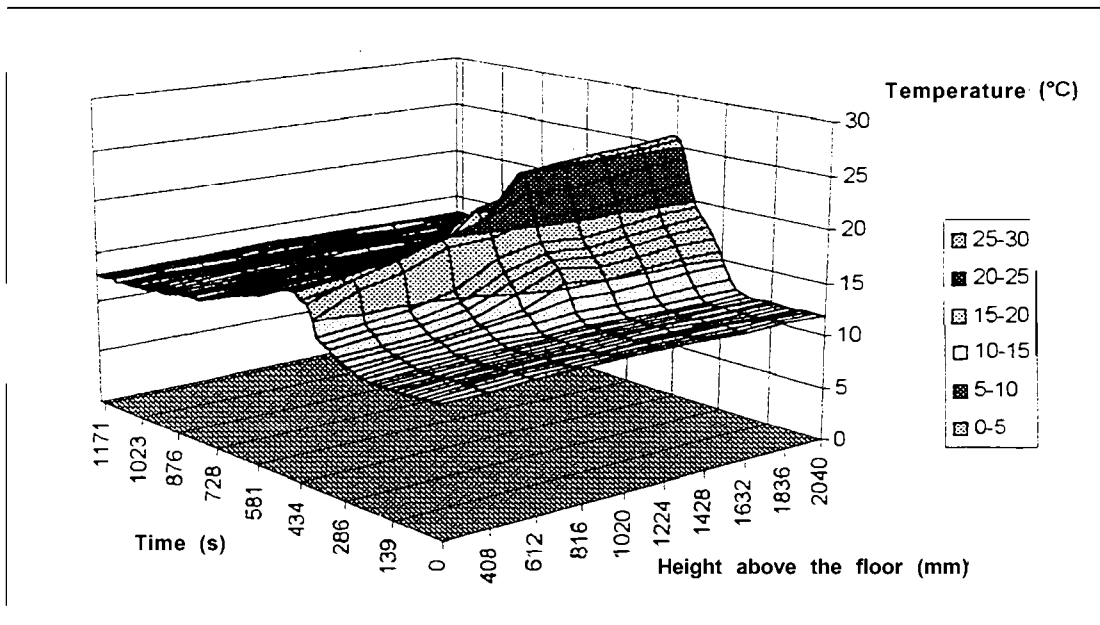

Figure FO8-24: Temperature distribution along the center line of Level 1M stairwell door

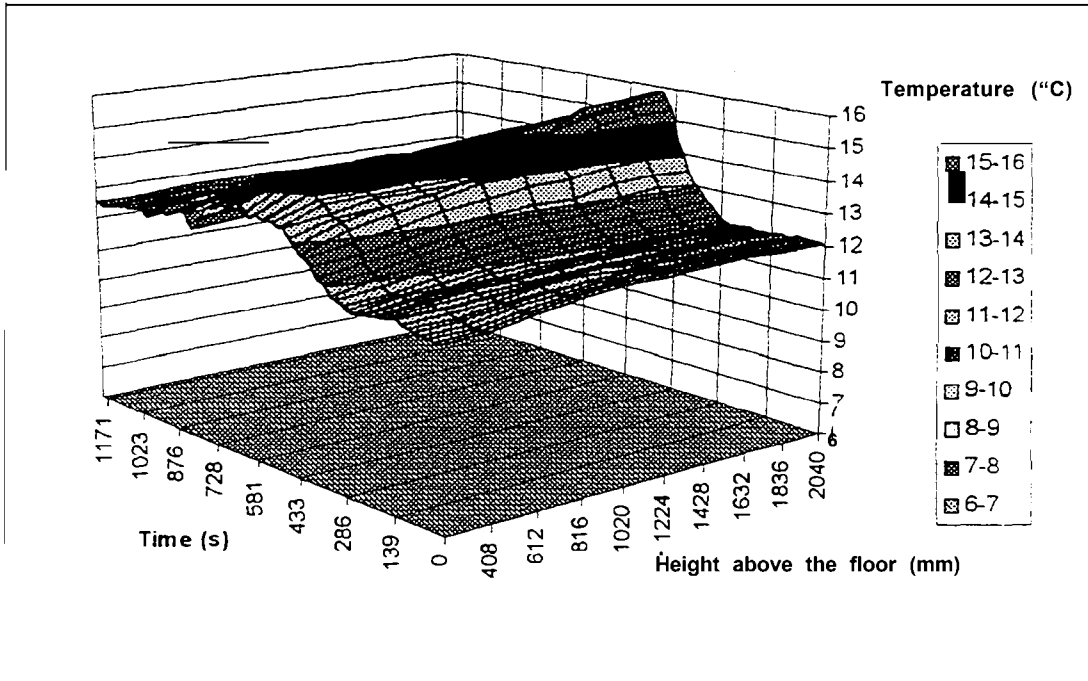

Figure FO8-25: Temperature distribution along the center line of Level 2 stairwell door

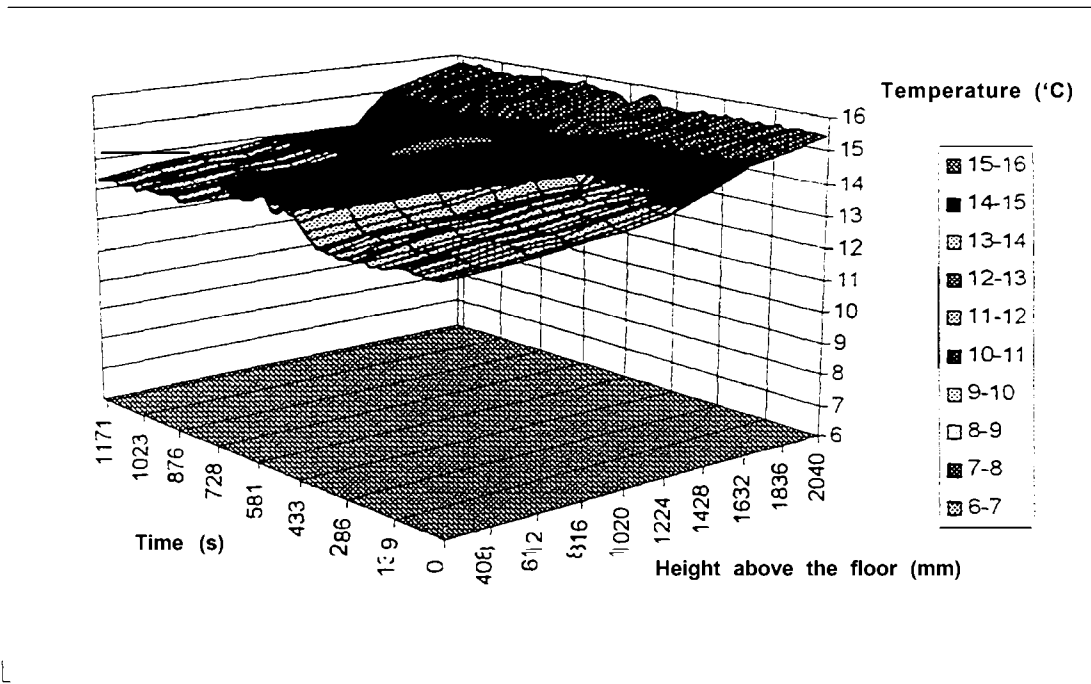

Figure FO8-26: Temperature distribution along the center line of Level 3 stairwell door

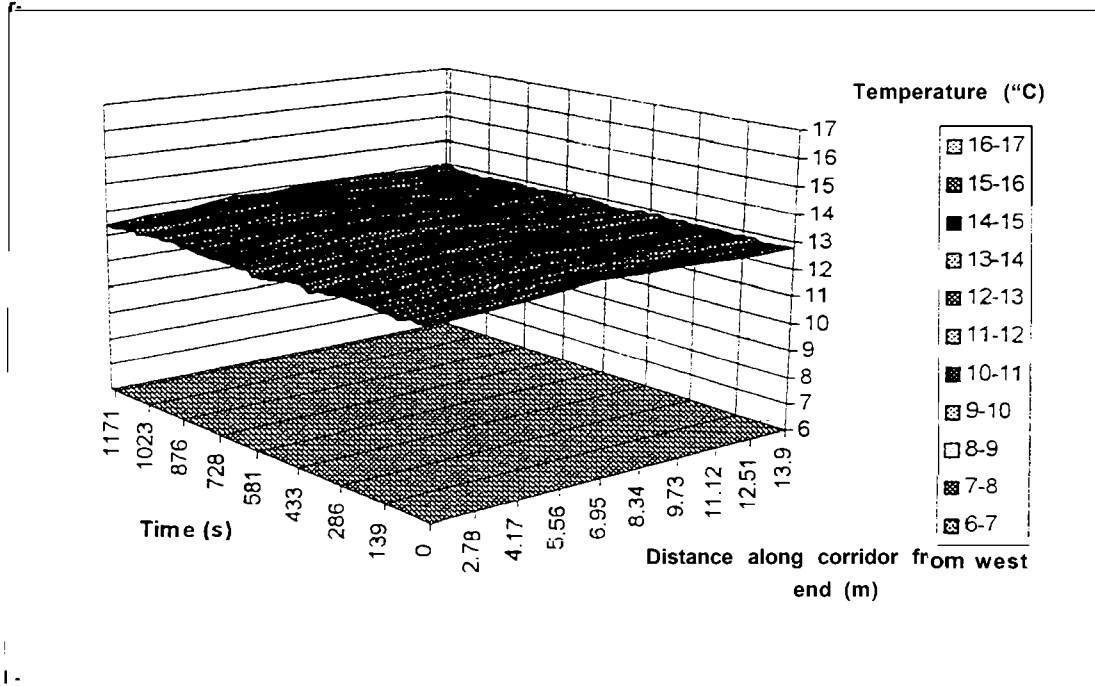

Figure FO8-27: Temperature distribution along Level 1M corridor (1.7 m above the floor)

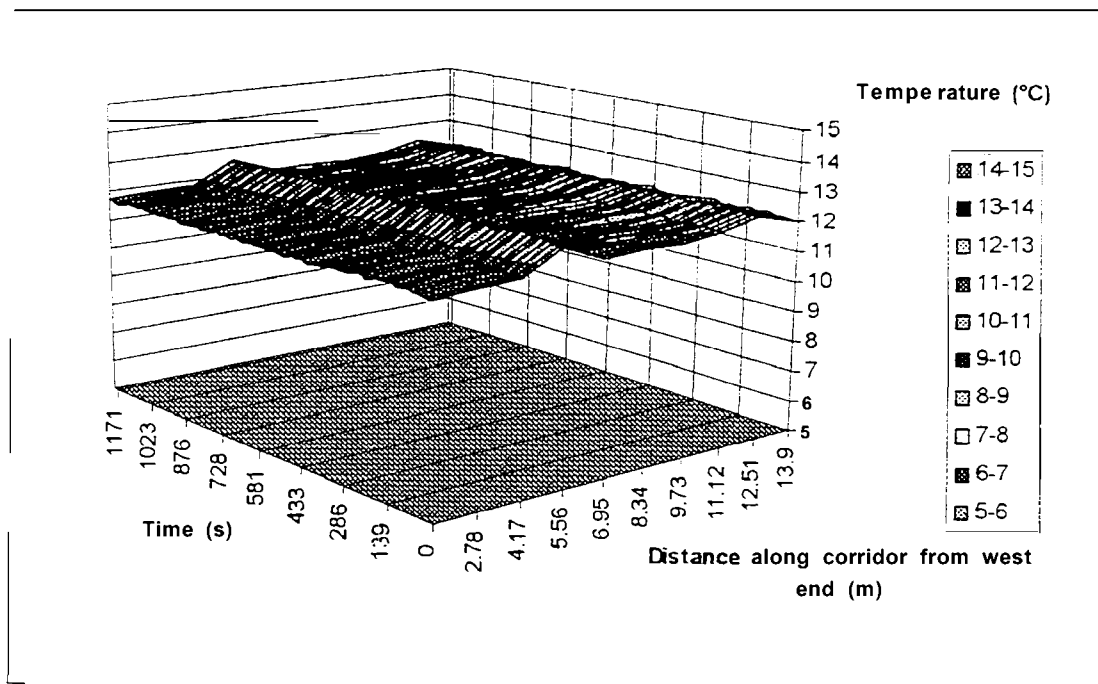

Figure FO8-28: Temperature distribution along Level 2 corridor (1.7 m above the floor)



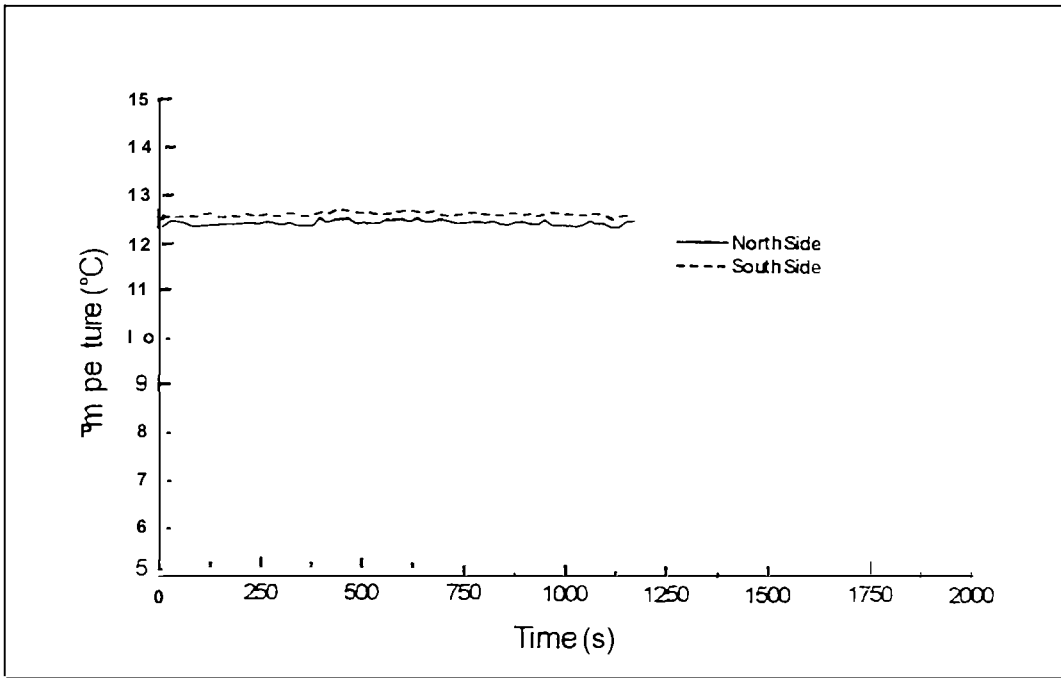

Figure FO8-29: Temperatures in Room 201 (1.7 m high)

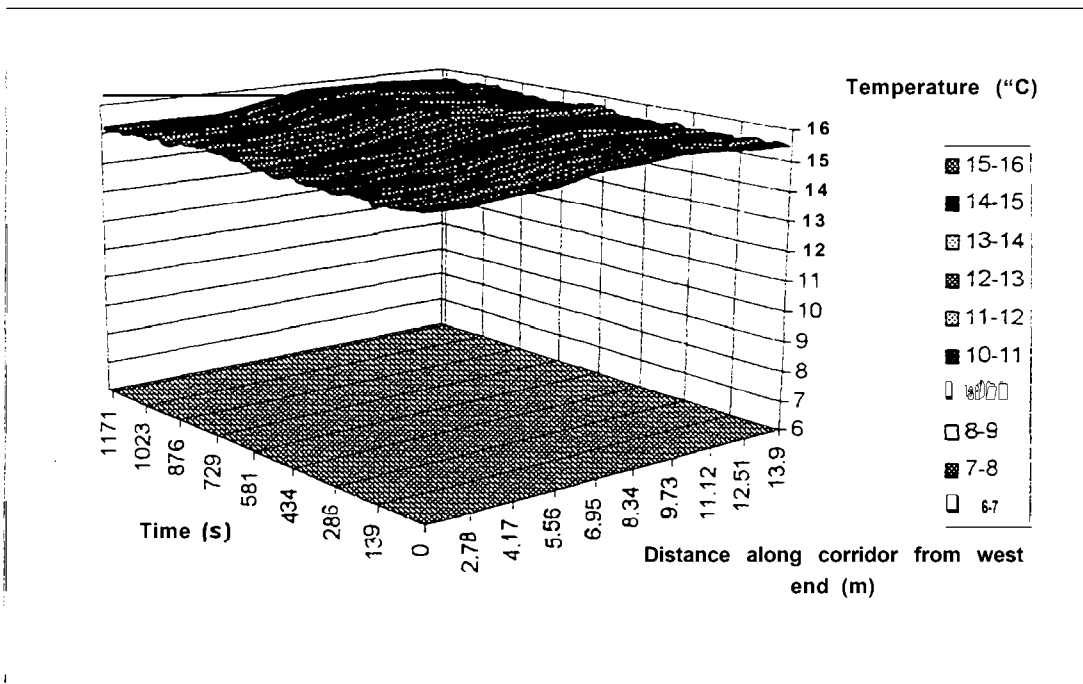

Figure FO8-30: Temperature distribution along Level 3 corridor (1.7 m above the floor)

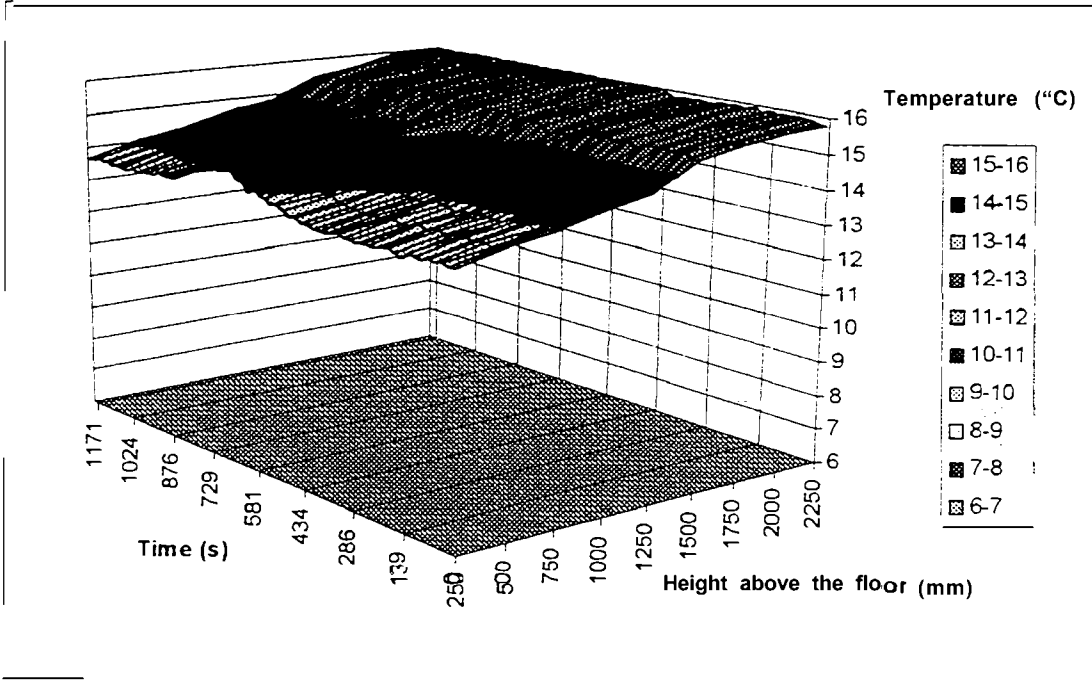

Figure FO8-31: Vertical temperature distribution in the center of Level 3 corridor

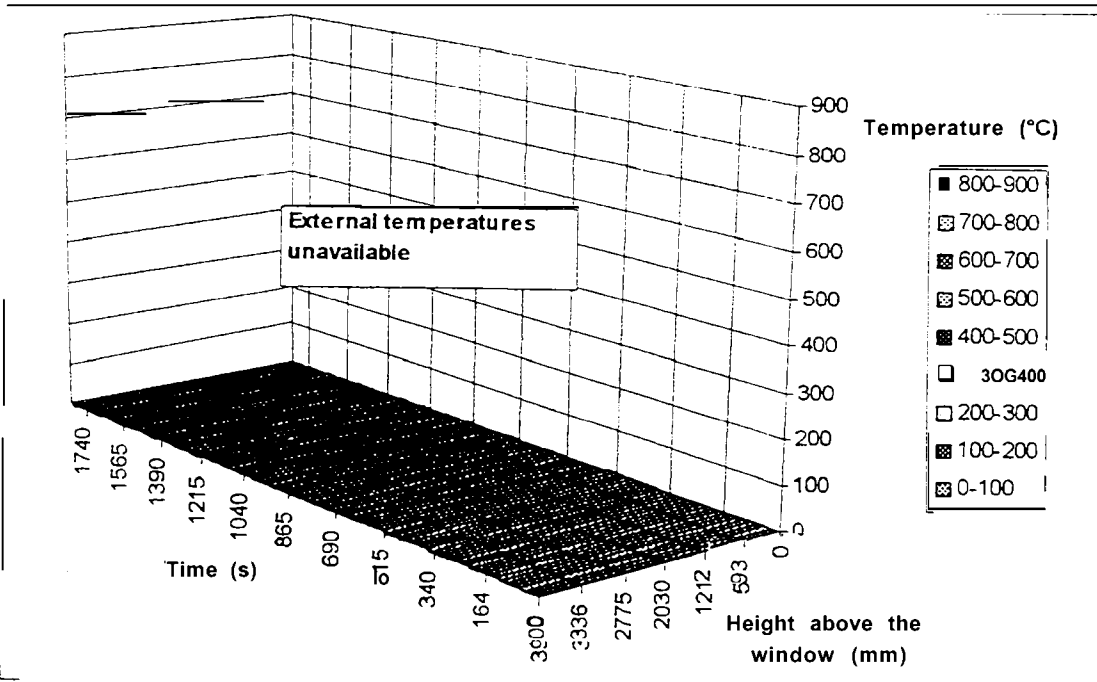

Figure FO8-32: External temperature along the center line of the bum room window (0.02 m from the wall)

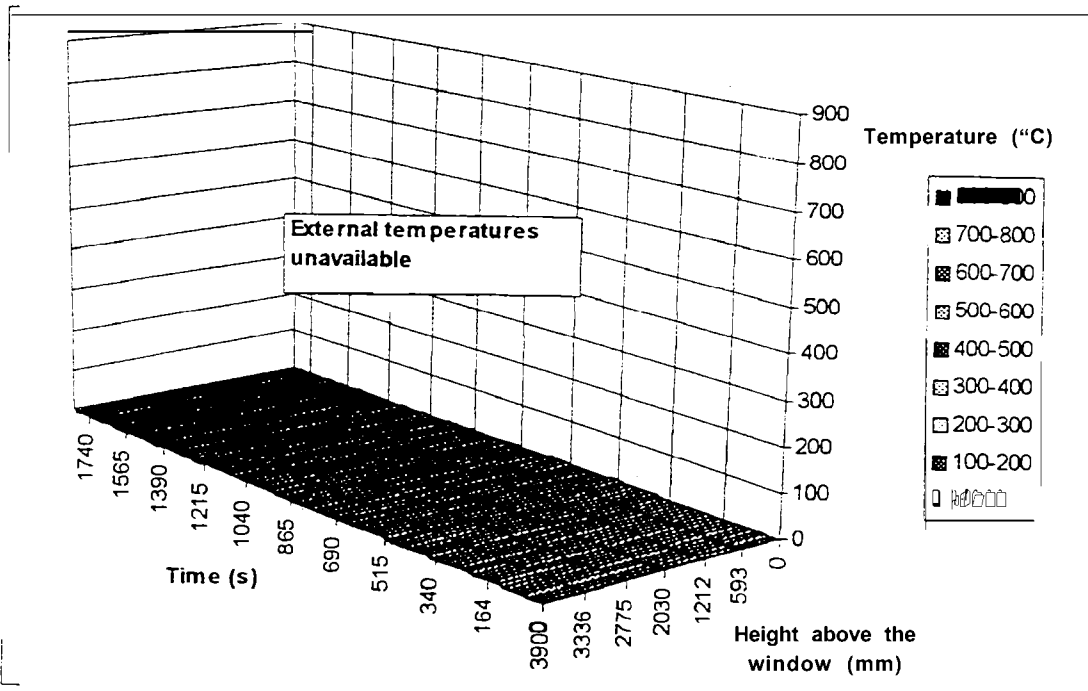

Figure FO8-33: External temperature along the center line of the bum room window (0.5 m from the wall)

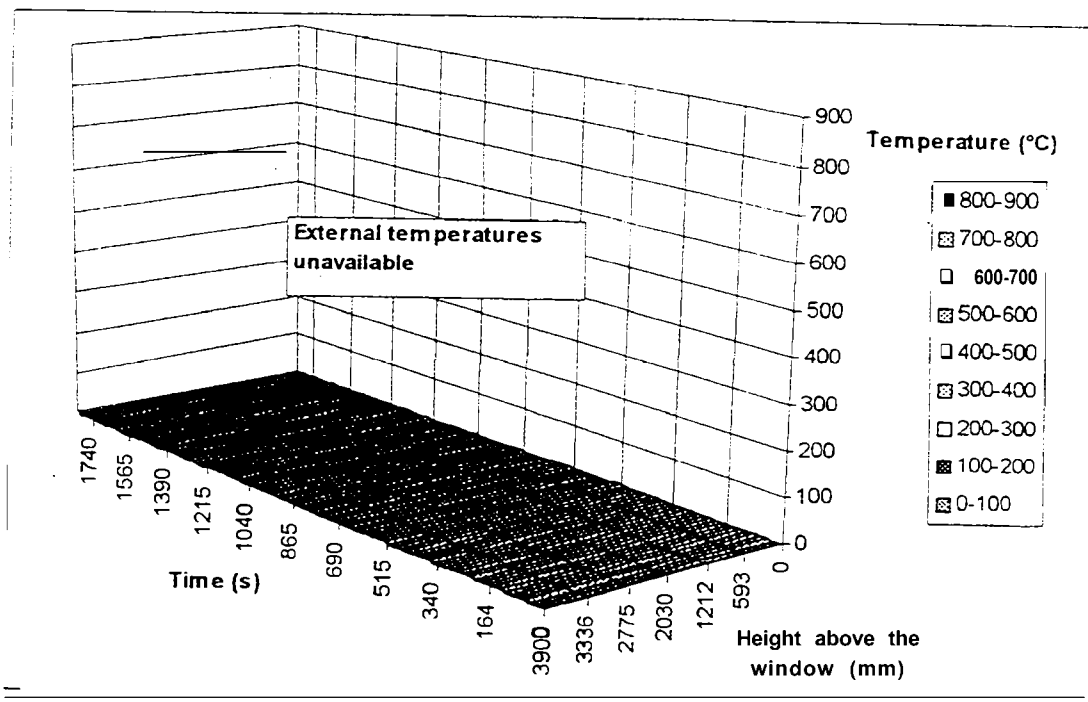

Figure FO8-34: External temperature along the center line of the bum room window (1.0 m from the wall)

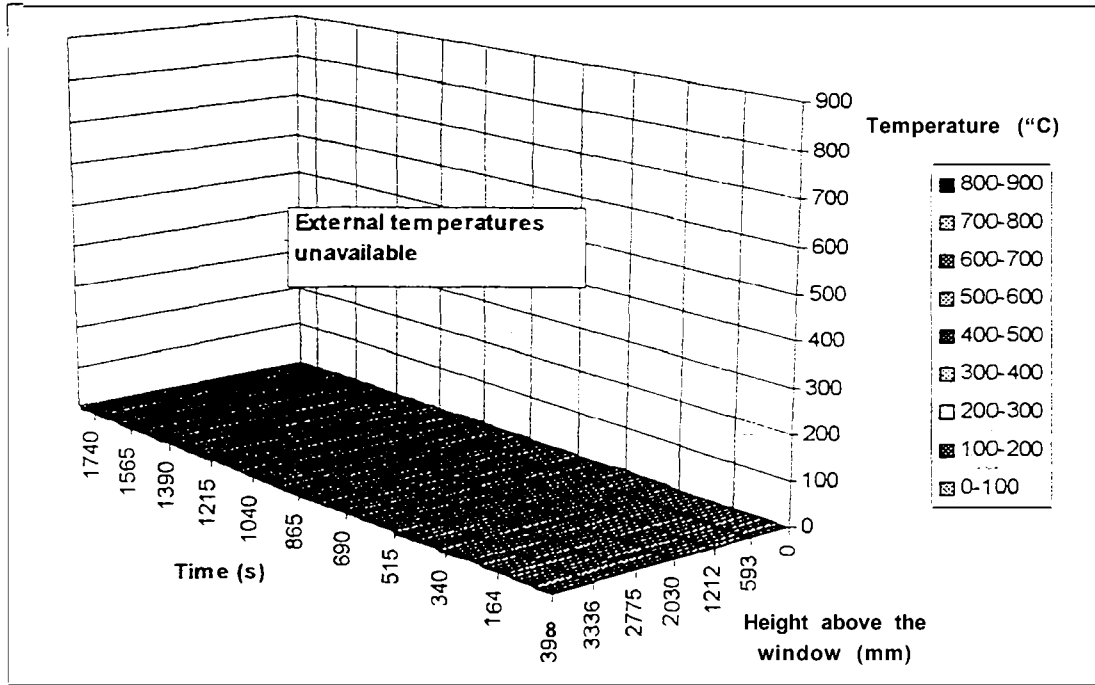

Figure FO8-35: External temperature along the center line of the bum room window (1.5 m from the wall)

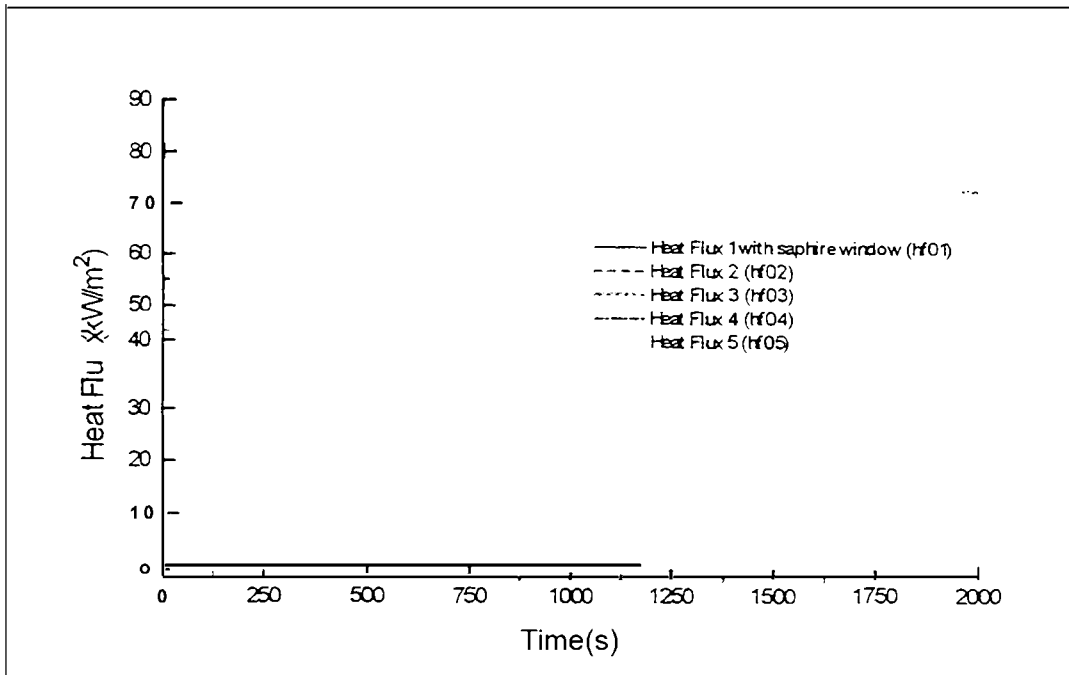

Figure FO8-36: External heat flux measurements (Refer to Figure 25 for locations)

## 17. GENERAL DISCUSSION

The fire tests were identical in fuel load and layout. The parameters changed were bum room door open/closed, Level 1 stairwell door open/closed, sprinklers charged/not charged with water and air handling on/off. The parameters adopted for each experiment are clearly detailed in Section 4.4 of this report.

### *17.1 Burn Room*

The maximum heat release rate (HEIR) in the bum room, in this test series, was 15.3 MW for test F07. This test had combustible lining in Level 1 corridor. This HHR was quite high compared to other tests when both the bum room door and the stairwell door were open. The maximum HHR achieved by F04 was 9.47 MW; the only difference between these two tests was F07 had combustible lining which increased the HHR by a third, making it the most severe fire in the series.

The lowest maximum HHR measured in the test series for when the bum room door was open and the air handling system was on was 3.0 MW for F05, (no HHR was available for the sprinkler test (F08)).

The maximum HHR measured for the bum room door closed condition was 10.8 MW in F02, 11.29 MW in F03 and 8.10 MW in F06, which have similar HHR results as the bum room door open condition.

The two tests which did not reach flashover were F05 and F08; both had the bum room door and Level 1 stairwell door open. F05 did not flashover and consumed less than 50 kg of the fuel load due to the combined effect of the smoke management and stair pressurisation system which prevented the spread of fire. F08 did not flashover because the sprinklers were activated and were able to control the fire. As can be seen from the graphs the activation of the first sprinkler did not control the fire - in fact it was still growing until the second sprinkler activated 100 seconds later, which controlled the fire almost immediately.

Time to flashover varied between each test in this series from 379 seconds for F06 to 860 seconds for F02. Although F06 and F02 had the same door conditions (closed), having the air handling system on in F06 aided the initial growth of fire which lead to flashover, whilst flashover in F02 would not have occurred had the window not been lowered. The time to flashover after the window was lowered or almost completely dislodged (90%) was approximately 2 to 3 minutes for F01, F04 and F07 but less than 30 seconds for F06. The tests in which the window was lowered only after the mass loss was 0.1 kg/s, (F02 and F03) had a longer time to flashover after the window was lowered- approximately 4 minutes. A summary of the occurrence of flashover in this test series is shown in Table 17.

For the bum room door open tests F01 (stairwell door closed), F04 (stairwell door open) and F05 (air handling on), the time to thermal untenability (100°C) in the bum room was between 3 18 and 341 seconds ( $\approx$  5.5 minutes) - using the average bum room temperature trace. Thermal untenability was not reached in the sprinkler test (F08).

The test which had combustible lining in Level 1 corridor, (FO7), reached thermal untenability at 270 seconds, which is closer to the results seen for the bum room door closed situation.

For the bum room door closed tests F02, F03 and F06 (air handling on), the time to thermal untenability (100°C) in the bum room was approximately 250 seconds ( $\approx$  4 minutes).

The maximum peak temperature in the bum room for all the fires tests, except FO5 and F08 was above 1000°C. The maximum peak temperatures in F05 and F08 were 336°C and 265°C respectively.

The maximum total heat flux in the bum room was above 100 kW/m<sup>2</sup> for all the fire tests except for F05 and F08 which had maximum total heat flux values of 11 kW/m<sup>2</sup> and 2 kW/m<sup>2</sup> respectively.

In each test of this series the bum room window cracked in the middle pane between the 3rd and 6th minute after ignition. Significant bowing of the bum room window was only seen when the bum room door was closed and in FO1 when the bum room door was open but the stairwell door was closed.

Detector and sprinkler activation times for devices in the bum room and other locations can be seen in Tables 15 and 16.

**Table 15: Sprinkler Detection Times (seconds)**

<b>Sprinkler Activation Time (seconds)</b>			
	<b>Burn Room</b>		<b>Level 1 Corridor</b>
<b>Test ID</b>	<b>SP1</b>	<b>SP2</b>	<b>SP3</b>
<b>FO1</b>	267	342	354
<b>FO2</b>	197	(QR-184) 276	*
<b>FO3</b>	226	(QR-213) 279	*
<b>FO4</b>	182	326	357
<b>FO5</b>	QR-301	340	*
<b>FO6</b>	250	270	*
<b>FO7</b>	255	288	315
<b>FO8</b>	270	382	-

Note: \* refers to the condition where detector did not activate  
 - indicates the detector was not used in the test or a fault was present

Unless otherwise stated the sprinkler is a standard response type sprinkler, (QR denotes a quick response type sprinkler). Sprinkler locations are shown in Figure 11.

**Table 16: Detector Activation Times in Seconds**

Detector Activation Times (seconds)								
Test ID	Bum Room			Corridor			Return Air Duct	
	SD06 thermal	SD04 ionisation	SD05 photo-optical	SD03 thermal	SD07 ionisation	SD08 photo-optical	SD01 ionisation	SD02 photo-optical
<b>FO1</b>	134		133	-				
F02	118	49	93	1399	318	314		
<b>F03</b>	136	54	114	*	244	279		
Test ID	Burn Room			Corridor			Return Air Duct	
	SD06 ionisation (no cap)	SD04 ionisation	SD05 photo-optical	SD03 thermal	SD07 ionisation	SD08 photo-optical	SD01 ionisation	SD02 photo-optical
F04	153	63	56	240	138	179		
<b>F05</b>	53	61	145	301	126	182	35	162
<b>F06</b>	55	64	138	*	338	404	38	143
F07	41	48	150	208	89	177		
<b>FO8</b>	33	41	134	204	111	170		

Note: \* refers to the condition where detector did not activate  
 - indicates the detector was not used in the test or a fault was present

**Table 17: Summary of Ventilation Conditions and Time to Flashover**

Test ID	Bum Room Door (D1)	Stairwell Door (D9)-Level 1	Other Conditions	Window lowered, time	Flashover time
<b>FO1</b>	Open	Closed		5:25	7:20
F02	Closed	Closed		9:50	14:20 <sup>#</sup>
F03	Closed	Closed		9:35	13:00 <sup>#</sup>
F04	Open	Open		*	9:00
<b>FO5</b>	Open	Open	Air Handling ON	*	*
F06	Closed	Closed	Air Handling ON	4:55	6:19
F07	Open	Open	Combustible linings	5:30	7:50
<b>FO8</b>	Open	Open	Sprinklers Charged	*	*

Note: \* refers to the condition where an event did not occur  
 # refers to the condition where flashover would not have occurred if window was not lowered

### 17.1.1 Repeatability- F02 & F03

To check repeatability of the fire tests two were done under the same conditions; F02 and F03. The results were very similar as can be seen in Figures 38 and 39. The delay seen in F02 when compared to F03 was due to the window being lowered later in F02 than in F03.

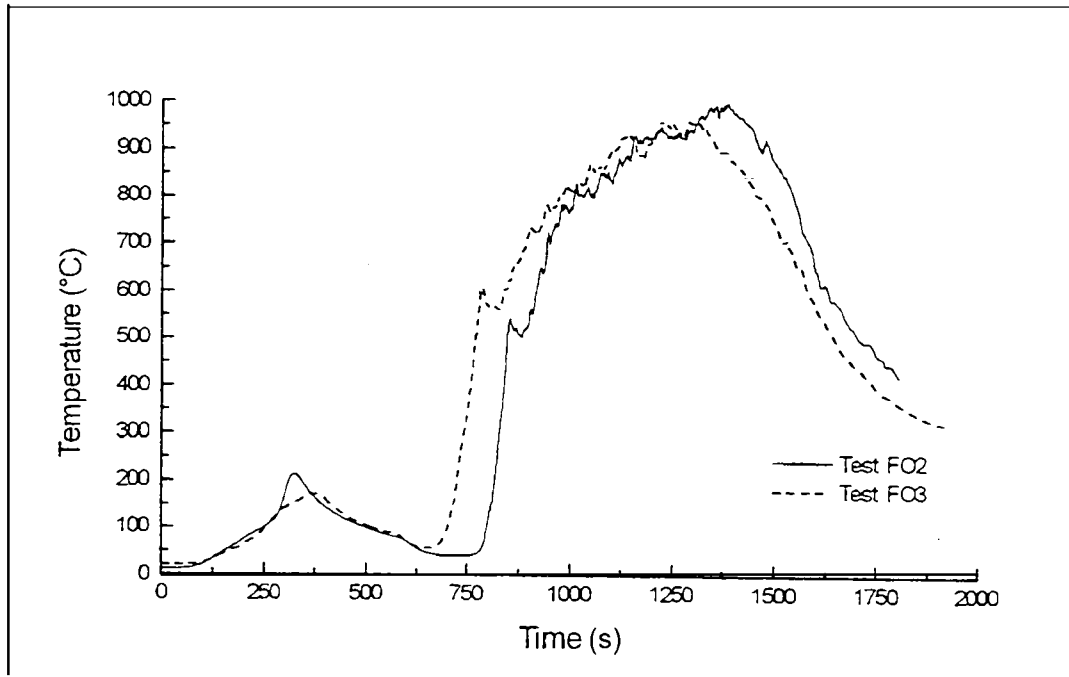

Figure 38 : Average burn room temperature for F02 & F03

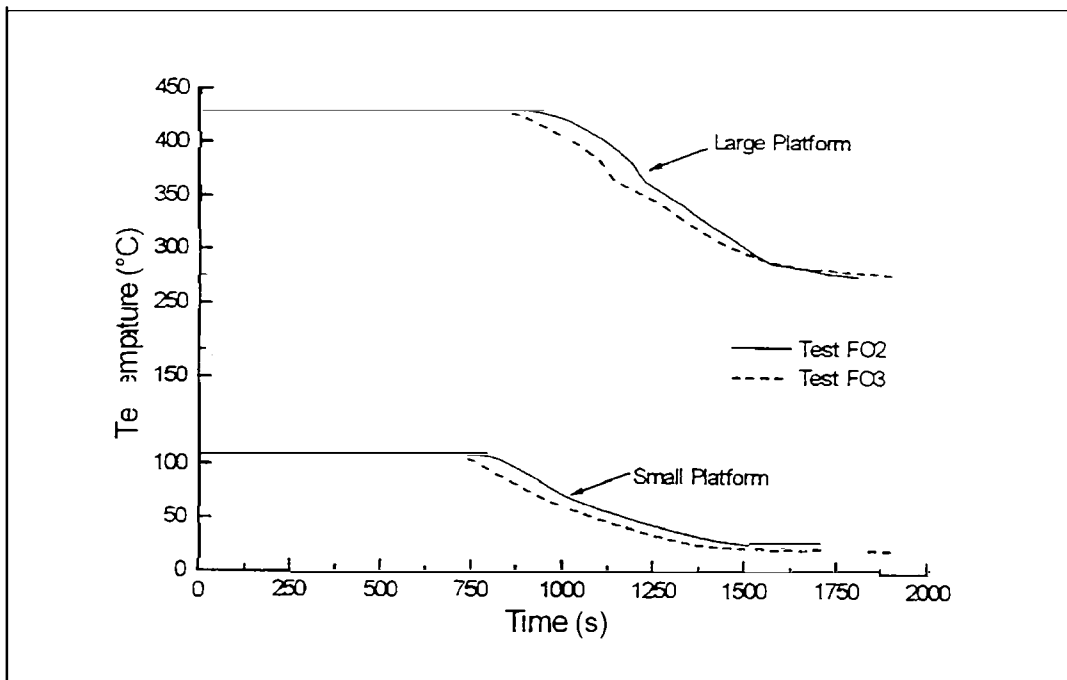

Figure 39 : Mass Loss on each platform in the burn room for F02 & F03



## ***17.2 Burn Room Door***

The conditions at the bum room door are dependant on whether the door was open or closed, as the instrumentation is in the corridor; note - no species concentrations were measured when the bum room door was closed, although temperatures were measured.

The maximum temperature at the burn room door, for the closed door condition was 850°C in F02 and 116°C in F03. The unusually high temperature in F02 was most likely due to gases/fire escaping through the edge of the door, this can be seen more clearly in Figure FO2-10. The temperature in F06 only reached 45°C at the bum room door.

The maximum temperature at the door for the test series with the door open was 970°C in F07. F04, which had the same conditions as F07 but without combustible wall linings, had a maximum temperature at the bum room door of 907°C. The maximum temperature at the door in FO1 was 793°C. The maximum CO & CO<sub>2</sub> concentrations at the bum room door for these tests was approximately 6.5 % and 13 %.

In tests F05 and FO8 similar maximum temperatures were recorded, namely 147°C and 150°C, but test FO8 had much higher maximum concentrations of CO and CO<sub>2</sub>; 0.4% CO and 4% CO<sub>2</sub> compared to 0.02% CO and 1% CO<sub>2</sub> for test F05.

For the open door tests the flow velocity was generally away from the bum room through the top half of the door.

## ***17.3 Level 1 Corridor and Stairwell Door***

The maximum temperature in Level 1 corridor when the bum room door was closed was 42°C in F03. The only test which the temperature in Level 1 corridor did not reach thermal untenability for when the bum room door was open was test F05 when air handling was on, (37°C). FO8 reached 100°C at a height of 2.0 m above the floor. All other tests with the bum room door open reached temperatures in excess of 400°C in Level 1 corridor.

The maximum temperature at the stairwell door when the bum room door was open was generally 80% of the maximum in the corridor.

## ***17.4 Stairwell Levels I, 1M, 2 and 3***

The CO and CO<sub>2</sub> concentrations in the stairwell in tests FO1, F02, F03, F05 and F06 were negligible, the maximums being 0.1% and 0.7% respectively. In these tests the oxygen concentrations did not drop more than 2 % on any level in the stairwell. The temperature on either side (north or south) of the stairwell or at stairwell doors in 1M, 2 or 3 did not rise more than 3°C above ambient. The optical density in F02, F03, FO5 and F06 was negligible in the stairwell at all levels. The maximum optical density in FO1 (Level 1 stairwell door closed) was 7.5 dB/m in Level 1 stairwell and 3 dB/m in Level 1M; the optical density in other areas was negligible. The pressure differences in

the stairwell for FO1, F02 and F03 were also negligible. The large pressure differences seen in F05 and F06 were due to the stair pressurisation sub system.

The maximum CO and CO<sub>2</sub> concentrations in FO8 were 0.2 % and 6 % respectively and the oxygen concentration fell to a minimum of 17%. The maximum temperature rise on either side of the stairwell and at stairwell doors 1 M, 2 or 3 was 18°C above ambient. The maximum optical density measured in FO8 was 15 dB/m at both Level 1 and 1M stairwell. The optical density in Levels 2 and 3 were approximately 5 dB/m. The pressure differences measured at each level in the stairwell were negligible.

The oxygen concentration in all levels of the stairwell decrease similarly in tests F04 and F07 by to 2 % before rising again 17 minutes later. The CO and CO<sub>2</sub> concentrations also show similar trends- in both tests the measured results were even greater than the calibrated range of the analysers. The CO<sub>2</sub> measured was greater than 10% in each level of the stairwell. The measured CO levels were greater than 3.5% for Levels 1, 1M and 2 and less than 0.25% on Level 3 stairwell. An interesting trend in both tests was the temperature on the north side of the stairwell was approximately 20°C greater than on the south side for Level 1 and 1M. The optical density was greater than 25 dB/m for both tests in all levels of the stairwell. The pressure differences in the stairwell were also very similar, gradually rising from 2 Pa (Level 1) to 25 Pa (Level 3). The maximum temperature measured at Level 1M stairwell door was above 100°C and less than 70°C for Levels 2 and 3 stairwell doors.

### ***17.5 Levels 1M and 2***

The stair doors to Levels 1M and 2 remained closed for each experiment. The maximum temperature rise did not exceed 4°C for all the fire tests in Levels 1M and 2 corridors or in Room 20 1.

### ***17.6 Level 3***

The stair door to Level 3 remained open for all the experiments,

The CO, CO<sub>2</sub> and optical density measured in FO1, F02, F03, FO5, F06 and FO8 in Level 3 corridor were negligible. The maximum rise in temperature for these tests was 3°C above ambient.

The CO and CO<sub>2</sub> measured in F04 and F07 in Level 3 corridor was less than 0.25% and greater than 10% respectively. The maximum optical density measured in the corridor was greater than 25 dB/m and the maximum temperature reached was 52°C for both tests.

### ***17.7 External Results***

No external temperature results were obtained for F05 and F08. The maximum heat flux obtained for these tests was 8 kW/m<sup>2</sup> and 0.1 kW/m<sup>2</sup> in the bottom center of 1M window (hf04), which indicate flame attack on the facade of the building was minimal.

The maximum temperature measured by the external grid was 890°C in F07 and F02. F01, F03 and F04 had maximum temperatures of 630°C, 850°C and 830°C respectively. This maximum temperature generally occurred 0.5 m away from the wall.

The maximum external total heat flux measured in this test series was 87.6 kW/m<sup>2</sup> in F03 at hf02. The magnitude of the heat flux at each location was not only dependant on the fire, but on the direction of the wind which would move the plume to one side of the window.

## 18. CONCLUSION

Comprehensive data was collected for eight flashover fire experiments in which the boundary conditions for each experiment were changed.

A set of criteria have been developed for lowering the window for this test series. These were used to eliminate variations in glass behaviour between experiments which would significantly alter ventilation conditions within the bum room.

The test which produced the most hazardous conditions throughout the building was F07, which had both the bum room door and Level 1 stairwell door open, and combustible linings in Level 1 corridor. The conditions produced by F04, which also had the bum room door open and the stairwell door open but no combustible linings, were very similar to F07 in all areas other than Level 1, where F04 produced slightly less hazardous conditions.

The tests with air handling on F05 (bum room door open, stairwell door open) and F06 (bum room door closed, stairwell door closed) produced very different conditions. F05 did not flashover and F06 had reached flashover at a faster time than all the other tests in this series. In test F05 the fire was controlled and isolated by the combined effect of the smoke extraction system and the stair pressurisation system. By closing the bum room door and Level 1 stairwell door in test F06 the effect of the stair pressurisation sub system in Level 1 corridor, and consequently the bum room was effectively eliminated. The air supplied to the room in test F06 before detector activation was enough to assist the fire to develop to a stage where the smoke extraction system could not prevent the spread of fire. The difference in activation times of the smoke management and stair pressurisation sub systems for the two tests was only 20 seconds.

The tests carried out to show repeatability (F02 and F03) produced results which were quite similar, before and after the window was lowered. It was consistently seen that when both the bum room door and the stairwell door were closed, the conditions on all other levels in the building and in the stairwell varied very little from ambient conditions. Although the fire in the bum room was quite severe in tests F02 and F03, the conditions in Level 1 corridor were not thermally hazardous except for directly outside the bum room door.

The conditions produced by test FO 1 in level 1, which had the stairwell door closed but the bum room door open, were less severe but similar to those produced by F04 and F07 (as described above). The conditions produced by FO1 throughout the rest of the building are similar to those seen in F02, F03, F05 and F06, except for optical density, which was greater (ie: less visibility).

The test in which the sprinkler was activated (FO8) produced more hazardous conditions in the stairwell than FO1, F02, F03, F05 and F06. The effect of the cooling induced by the water had the effect of causing greater circulation of the smoke than in a fire without sprinklers; this allowed the smoke to travel in greater concentrations into Level 1 corridor and into the stairwell.

The ionisation type smoke detector in the center of the bum room activated before the thermal detector (when present) and the photo-optical smoke detector in all tests except F04 when the photo-optical smoke detector activated 10 seconds earlier. When detectors were placed in the return air duct the high sensitivity ionisation type smoke detector activated at least 100 seconds earlier than the high sensitivity photo-optical smoke detector, which controlled the activation of the smoke management and stair pressurisation sub systems.

The conditions in the bum room were determined by ventilation conditions, including door open/closed, window open/closed, air handling on/off and sprinklers charged/not charged. It can be seen from the results of this test series the most hazardous conditions throughout the building are produced when both the door to the room of fire origin and the stairwell door to the level of fire origin are open. The best case for limited smoke and fire spread was when both the door to the room of fire origin and the stairwell door to the level of fire origin are closed; this scenario self-extinguished when ventilation was unchanged.

Ultimately these experimental results will be used to validate computer models with the aim of obtaining more accurate predictions of realistic fire conditions.

## **19. RECOMMENDATIONS**

This experimental program explored eight fire scenarios. If further experiments are carried out in this area it is suggested that another sprinkler test be done, using a residential sprinkler system to compare these results to the “Light Hazard System” used in this series of experiments. Another recommendation would be to run a test with the sprinklers charged with water, the air handling system on and the bum room door closed, to observe the development of the fire. The gas analysers were also limited; the measured concentrations over-ranged or plateaued in some tests, therefore a more accurate picture of toxicity would be available if gas analysers had a greater range. Further work also needs to be carried out in the area of glass behaviour in fires, particularly in the area of dislodgment.

## **20. ACKNOWLEDGMENTS**

This project was conducted under contract for the Fire Code Reform Center Ltd (FCRC) and was supported by Victoria University of Technology.

This FCRC flashover fire test series was undertaken with the assistance of Mr S. Stewart and Mr M. Coles who were responsible for the experimental building, instrumentation setup, data recording and conduct of the experiment. The experiments were setup with the assistance of Mr M. Hildebrandt, Mr B. Doughty, Ms S. Klopovic, Dr Y. He and Mr A. Fernando. Dr Y. He and Dr M. Luo also provided guidance and support. The data sorting program used to process the data was written by Mr H. Li. The photographs in this report were taken by Mr M. Coles and Ms S. Klopovic.

This experimental program was carried out under the overall supervision of Prof. V. Beck and Associate Prof. P. Beever.

## **2 1. References**

1. Moore, I. and Beck, V. (1996), "Smouldering and Flaming Fires- an Experimental Program", CESARE Report No. 96-001, Centre for Environmental Safety and Risk Engineering, Victoria University of Technology.
2. Tien, C. L., Lee, K. Y. and Stretton, A. J., 1988, "Radiation Heat Transfer", The SFPE Handbook of Fire Protection Engineering, National Fire Protection Association.

# **APPENDIX 1**

## **FIRE LOAD STATISTICS**

## FIRE LOAD STATISTICS

Table 1: Summary of Fuel Loads

	Fuel Load (kg/m <sup>2</sup> )	Standard Deviation (kg/m <sup>2</sup> )
<b>2.1 Warren Center Data</b>	49	
<b>2.2 NFPA Statistics:</b>		
<i>Living Room</i>	19.1	5.5
<i>Family Room</i>	13.2	3.2
<i>Bedroom</i>	21.1	5.6
<i>Dining Room</i>	17.6	5.0
<i>Kitchen</i>	15.7	3.8
<b>2.3 Swedish Data:</b>		
<i>Dwelling</i>	30.1	4.4
<i>Hotel</i>	14.6	4.2
<b>2.4 American Data:</b>		
<i>Living Room</i>	52.9	25.5
<i>Family Room</i>	80.9	57.3
<i>Bedroom</i>	62.7	50.5
<i>Dining Room</i>	49.5	23.5
<i>Kitchen</i>	55.4	31.4
	Fuel Load kg/m <sup>2</sup> (Actual Weight)	Fuel Load kg/m <sup>2</sup> (Modified Weight)
<b>2.5 Recent Survey:</b>		
<i>Living/Dining Room</i>	16.83	14.53
<i>Kitchen/Breakfast Area</i>	20.60	14.86
<i>Main Bedroom</i>	39.41	32.36
<i>Corridor</i>	2.22	2.14

## Fire Load Statistics:

### 1. Room Dimension Statistics

The Warren Centre Project reported representative room and compartment dimensions for apartments.

Typical bedroom dimensions are 12 m<sup>2</sup> to 16 m<sup>2</sup> for apartment situation 14 m<sup>2</sup> was used as an average.

Average total apartment size = 95 m<sup>2</sup> approx.

*[Warren Centre Project - section 8.2.10.2 Book 1]*

### 2. Fuel Load Statistics

#### 2.1 Warren Centre Data

The expected fuel load is approximately 49 kg/m<sup>2</sup> (linear interpolation of scale)  
*[Warren Centre Project - Table 2b, Appendix 3, Part 3, page 3.46 & page 3.9 under fuel load characteristics, Book 1]*

#### 2.2 NFPA Statistics

Average Contents Fuel Loads:

Living Room = 19.1 kg/m<sup>2</sup>, Stand. Dev. = 5.5 kg/m<sup>2</sup>

Family Room = 13.2 kg/m<sup>2</sup>, SD = 3.2 kg/m<sup>2</sup>

Bedroom = 21.1 kg/m<sup>2</sup>, SD = 5.6 kg/m<sup>2</sup>

Dining Room = 17.6 kg/m<sup>2</sup>, SD = 5 kg/m<sup>2</sup>

Kitchen = 15.7 kg/m<sup>2</sup>, SD = 3.8 kg/m<sup>2</sup>

Using representative values of average = 20 kg/m<sup>2</sup> and SD = 5 kg/m<sup>2</sup>:

For 50% of data = average + 0 x SD = 20 kg/m<sup>2</sup>

For 80% of data = average + 0.84 x SD = 20 + 0.84 x 5 = 24.4 kg/m<sup>2</sup>

Use 2xSD for 97.75 percentile, 3xSD for 99.86 percentile

*[NFPA Fire Protection Handbook Table 7-9D]*



### 2.3. Swedish Data

Harmathy and Mehaffey quote the following figures based on Swedish data:

Dwelling	Mean = 30.1 kg/m <sup>2</sup>	SD=4.4 kg/m <sup>2</sup>
Hotel	Mean= 14.6 kg/m <sup>2</sup>	SD=4.2 kg/m <sup>2</sup>

*[Fire Safety Science and Engineering, T Z Harmathy, p 168]*

### 2.4. American Data

A survey done by the American National Institute of Standards and Technology found the following data for contents fire load in an attached single family home:

Living Room: Movable Contents	Mean = 30.1 kg/m <sup>2</sup>	SD = 20 kg/m <sup>2</sup>
Interior Finish	Mean = 22.1 kg/m <sup>2</sup>	SD =12.3 kg/m <sup>2</sup>
<b>Total fire load</b>	<b>Mean = 52.9 kg/m<sup>2</sup></b>	<b>SD = 25.5 kg/m<sup>2</sup></b>
Family Room: Total Fuel Load	Mean=80.9 kg/m <sup>2</sup>	SD=57.33 kg/m <sup>2</sup>
Bedroom: Total Fuel Load	Mean=62.7 kg/m <sup>2</sup>	SD=50.5 kg/m <sup>2</sup>
Dining Room: Total Fuel Load	Mean=49.5 kg/m <sup>2</sup>	SD=23.5 kg/m <sup>2</sup>
Kitchen: Total Fuel Load	Mean=55.4 kg/m <sup>2</sup>	SD=3 1.4 kg/m <sup>2</sup>

Note: These fuel loads have been derived from a load transfer function specified in the reference and have been modified.

*[NBSIR 80-2155: Single-Family Residential Fire and Live Loads Survey, L.A. Issen, Table 5-14]*

The distribution or composition of the fire load with respect to materials in attached homes was found to be :

Timber:	11.3 kg/m <sup>2</sup>
Paper:	5.88 kg/m <sup>2</sup>
Plastic:	4.07 kg/m <sup>2</sup>
Fabric:	1.96 kg/m <sup>2</sup>
Other:	0 kg/m <sup>2</sup> (includes any chemicals)
<b>Total:</b>	<b>23.23 kg/m<sup>2</sup></b> over 32% of the floor area

*[NBSIR 80-2 155: Single-Family Residential Fire and Live Loads Survey, L.A. Issen, Table 8-3]*

## 2.5 Recent Survey of a Residency

A survey done by a student from the graduate diploma class found that his residency had the following fire load:

Living/Dinning Room: 16.83 kg/m <sup>2</sup>	Modified: 14.53 kg/m <sup>2</sup>
Kitchen/Breakfast Area: 20.60 kg/m <sup>2</sup>	Modified: 14.86 kg/m <sup>2</sup>
Main Bedroom: 39.41 kg/m <sup>2</sup>	Modified: 32.36 kg/m <sup>2</sup>
Corridor: 2.22 kg/m <sup>2</sup>	Modified: 2.145 kg/m <sup>2</sup>

Note: The modified fuel load has been multiplied by a NBFSSC derating factor corresponding to item.

## **APPENDIX 2**

# **AIR HANDLING/SMOKE MANAGEMENT CONTROL COMMISSIONING REPORT**

**Center for Environmental Safety and Risk Engineering**

**Fiskville Fire Test Facility**

**Test-Adjust-Balance Report**

**Prepared by**

**Ben White  
&  
Bruce Penglis**

**21st July 1995**

The aim of this brief test was to set up the air handling systems installed at CESARE's fire test facility after recent modification to provide predetermined air flow quantities. Also, this required that the system be overlooked to ensure proper operation- Equipment used included a flowhood to cover a 300mm x 300mm square face diffuser, a Pacer Industries DTA4000 digital anemometer (calibrated 7/1 1/92), a Clipsal clip on ammeter, and a Setra C264, ± 625 Pa differential pressure transducer (4-20 mA output).

### Theory

The determination of air supply rates was done in light of several methods available. The class of occupancy; residential, requires basic ventilation rates to be produced - 6 air changes per hour. General check figures for such an occupancy class are based on the general requirement unless a particular operation requires higher heating or cooling, (i.e. high equipment load). Cooling load calculations are generally not done for this application, though in this instance preliminary estimates were conducted using Temper (load estimation program).

Table 1 Cooling load calculations for various conditioned areas. Lo&s are for one level only

Room	101	102	103	104	Corridor
Conditioned room combination	Load V (l/s) (W)	Load V (l/s) (W)	Load V (l/s) (W)	Load V (l/s) (W)	Load V (l/s) (W)
Rooms 101,102, 103, and 104.	935 78	1272 101	446 37	835 70	-
Rooms 701,102, 103, and corridor	899 75	1246 104	43 5 3 6	- -	1891 158'
6 air changes/hr (4.2 l/s/m <sup>2</sup> )	56	37	- 44	- 56	- 92
5.0 l/s/m <sup>2</sup>	67	44	- 52	- 67	- 109
Final Design	2 x 35	45	50	2 x 35	50

- Loads are peak loads as calculated at December
- Loads are calculated for level one; hence small variations may exist for levels 1M and 2.
- All calculations done using program TEMPER.

Values were chosen in the final design figures which satisfied most design criteria listed above. Cooling load values for room 102 are high because Temper takes into account absorbance of heat by the floor from incident heat via windows; since room 102 has a large window area, the result is quite high. In reality, this load would be counteracted by curtains or blinds, thus not requiring the air conditioning plant to cater for this load - it is justified to lower to flow requirement closer to a general design value of 5.0 l/s/m<sup>2</sup>. The corridor on the other hand would normally have an additional two or three outlets because of its length. Based on this assumption, and observation of cooling loads, a design figure of 50 Us per outlet was chosen (only one outlet currently installed).

## Method

After ensuring that the air supply system was operating correctly, the appropriate operating conditions were set up as would be required for normal operation of the units.

- supply air dampers to all levels fully open via control panel
- return air dampers from all levels fully open via control panel
- normal cycle operation (not economy cycle-100% outside air)
- both supply air fans switched on high from distribution board
- bypass dampers set to around 50% initially, ie. prior to any supply outlet measurements
- all supply air outlets connected, joints sealed, diffusers installed. and opposed blade dampers open (checked because of recent installation).

Once the operation had been set up correctly, base measurements were taken to observe the gross air supply quantities. A flowhood was constructed, and used in conjunction with a wind vein anemometer to measure air flow rates

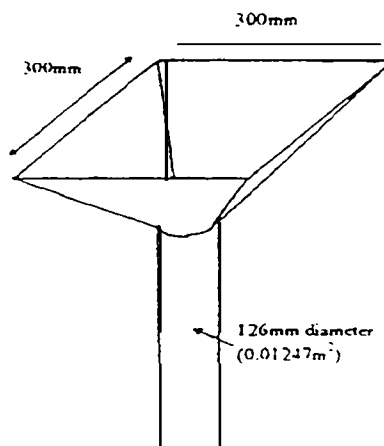

Figure 1 Flowhood construction

initially. after making preliminary measurements to most outlets within the supplied floors (levels 1, 1M, and 2). the air supply quantities has to be altered. It was eventually found that supply air fan 1 (supplying level 2) had to be set to 47% bypass. while supply air fan 2 was Set to 70% bypass (levels 1 and 1M)

The flow velocity was measured by taking an observed average reading from the displayed flow velocity on the anemometer. Obviously, fluctuations occur due to boundary flow conditions, and fluctuations in fan performance during operation (turbulent flow regime in supply air ducts).

Two runs were conducted where the flow rates out of each damper were adjusted by changing the angle of opposed blade dampers at each diffuser outlet. The first run was to set each outlet within close proximity of the design values, and the final run to increase the accuracy of the flow rates produced. Prior to establishing the correct bypass arrangement for each supply air fan, several preliminary runs were conducted in order to get gross supply rates to each outlet as required.

Once flow velocities were of satisfactory nature, results were recorded as given below.

## Results

**Table 1 Air supply rate results**

	Diffuser Location						Net
	101D	101W	102	103	Corr		
Level 1	101D	101W	102	103	Corr		
Av velocity	2.81	2.83	3.65	4.01	4.08		
Flow (l/s)	35	35	46	50	51		
Design	35	35	45	50	50		217
Level 1M	1M01D	1M01W	1M02	1M03	1M04D	1M04W	
Av Velocity	2.82	2.82	3.62	3.65	2.78	2.84	
Flow (i/s)	35	35	45	46	35	35	
Design	35	35	45	50	35	35	231
Level 2	201 D	201 w	202	203	204 D	204 W	
Av Velocity	2.80	2.83	3.60	<b>3.95</b>	2.81	2.83	
Flow (l/s)	35	35	45	49	35	35	
Design	35	35	45	50	35	35	234

- Supply air fan 1 total air      **234 l/s (70% bypass)**
- Supply air fan 2 total air      **448 l/s (47% bypass)**

**Table 2 Motor current**

Motor current	Phase	Phase	Phase
	1	2	3
SAF 1	2.5	2.2	2.0
SAF 2	2.0	2.5	2.0

## Conclusion

The air supply system was satisfactorily commissioned to supply air flow rates as show above in results. Relatively high accuracy was achieved by small changes in opposed blade dampers and bypass arrangements. It is suggested that after the completion of any significant fire experiments that diffusers in the vicinity which are prone to heat damage should be quickly checked to ensure correct flow rates (heat may affect opposed blade damper position).

## **APPENDIX 3**

### **AUSTRALIAN WOOL TESTING AUTHORITY TEXTILES TESTING REPORT**



# AWTA TEXTILE TESTING

26 Robertson Street, Kensington, Victoria 3031  
P.O. Box 240 North Melbourne, Victoria 3051  
Phone (03) 9371 2126 Telex AA35301 Fax (03) 9376 3469  
Australian Wool Testing Authority Ltd - A.C.N. 006 014 106  
trading as AWTA Textile Testing

## TEST REPORT\*

CLIENT : VICTORIA UNIVERSITY  
OF TECHNOLOGY  
BALLARAT ROAD  
FOOTSCRAY VIC

TEST NUMBER : 7-463018-MV  
DATE : 19.07.96

SAMPLE DESCRIPTION FIVE SAMPLES OF TEXTILE PRODUCTS

REF: A - PINK CUT PILE TUFTED CARPET  
NOM: 80/20 WOOL/POLYPROPYLENE  
B - WHITE FILLER FIBRE  
NOM: DACRON  
C - MULTI-COLOURED/BROWN PILE UPHOLSTERY FABRIC  
NOM PILE: POLYESTER  
D - BLACK WEBBING  
NOM: TEFLON  
E - CALICO WOVEN FABRIC  
NOM: COTTON

001.7-1983  
ION: 5

FIBRE ANALYSIS - PILE YARN

SAMPLE A

SPECIMEN	1	2	MEAN
WOOL (AT 15.00% REGAIN)	77.4	77.8	78.1
POLYOLEFIN (AT 2.00% REGAIN)	22.6	21.2	21.9%

CLEAN DRY MASS WITH AGREED ALLOWANCES FOR MOISTURE

PRETREATMENT WITH 0.1% DETERGENT SOLUTION CONDUCTED

3

8

(CONTINUED NEXT PAGE)

PAGE

1

© Australian Wool Testing Authority Ltd  
Copyright - All Rights Reserved



This Laboratory is registered by the National Association of Testing Authorities, Australia, for:  
- Chemical Testing of Textiles & Related Products : Registration No. 983  
- Mechanical Testing of Textiles & Related Products : Registration No. 985  
- Heat & Temperature Measurement : Registration No. 1356

\* The above tests have been performed in accordance with NATA's terms of registration. Samples and their identifying descriptions are normally submitted by the client unless otherwise stated. AWTA Textile Testing makes no warranty, implied or otherwise, as to the source of the tested sample. The above tests relate only to the sample tested. This document shall not be reproduced except in full and shall be rendered void if amended or altered. This document, the name AWTA Textile Testing or AWTA Ltd may not be used in any form of advertising without the prior written consent of the Managing Director of AWTA Ltd.



AUTHORISED SIGNATURE

DJ WARD B.Sc., M.A.I.A.S.  
MANAGING DIRECTOR

# AWTA TEXTILE TESTING

26 Robertson Street, Kensington, Victoria 3031  
P.O. Box 240 North Melbourne, Victoria 3051  
Phone (03) 9371 2126 Telex AA35301 Fax (03) 9376 3469  
Australian Wool Testing Authority Ltd - A.C.N. 006 014 106  
trading as AWTA Textile Testing

## TEST REPORT

CLIENT : VICTORIA UNIVERSITY  
OF TECHNOLOGY  
BALLARAT ROAD  
FOOTSCRAY VIC

TEST NUMBER : 7-463018-M  
DATE : 19.07.96

AWTA 50-1994  
CHEMICAL METHOD

### TOTAL FIBRE MASS

SPECIMEN	MASS	UNIT
1	1032	g/m <sup>2</sup>
2	1050	
3	1063	
4	1032	
5	1060	

MEAN 1047 g/m<sup>2</sup>  
COEFFICIENT OF VARIATION 1.4 %

THE RESULTS SHOULD BE REGARDED AS A GUIDE AND ARE BASED UPON A 78.1 % WOOL CONTENT. THE PRECISION OF THE METHOD IS UNKNOWN AS THE PROCEDURE USED TO SEPARATE FIBRE FROM BACKING INVOLVES CHEMICAL DISSOLUTION.

### SAMPLE A

AS 2001.2.13-1987

### MASS PER UNIT AREA

	C	E	UNIT
MEAN	492	165	g/m <sup>2</sup>
NO OF SPECIMENS	3	2	
AREA OF SPECIMENS	154	154	cm <sup>2</sup>

69373

(CONTINUED NEXT PAGE) PAGE

© Australian Wool Testing Authority Ltd  
Copyright - All Rights Reserved



This Laboratory is registered by the National Association of Testing Authorities, Australia, for:

- Chemical Testing of Textiles & Related Products : Registration No. 983
- Mechanical Testing of Textiles & Related Products : Registration No. 985
- Heat & Temperature Measurement : Registration No. 1356

\* The above tests have been performed in accordance with NATA's terms of registration. Samples and their identifying descriptions are normally submitted by the client unless otherwise stated. AWTA Textile Testing makes no warranty, implied or otherwise, as to the source of the tested sample. The above tests relate only to the sample tested. This document shall not be reproduced except in full and shall be rendered void if amended or altered. This document, the name AWTA Textile Testing or AWTA Ltd may not be used in any form of advertising without the prior written consent of the Managing Director of AWTA Ltd.



*[Signature]*  
AUTHORISED SIGNATORY

D.J. WARD B.Sc., M.A.I.A.S.  
MANAGING DIRECTOR

# AWTA TEXTILE TESTING

26 Robertson Street, Kensington, Victoria 3031  
 P.O. Box 240 North Melbourne, Victoria 3051  
 Phone (03) 9371 2126 Telex AA35301 Fax (03) 9376 3469  
 Australian Wool Testing Authority Ltd - A.C.N. 006 014 106  
 trading as AWTA Textile Testing

## TEST REPORT\*

CLIENT : VICTORIA UNIVERSITY  
 OF TECHNOLOGY  
 BALLARAT ROAD  
 FOOTSCRAY VIC

TEST NUMBER : 7-463018-MV  
 DATE : 19.07.95

2001.7-1983

ANALYSIS OF FIBRES

SAMPLE B:

POLYESTER 100%

TWO POLYESTER STRUCTURES PRESENT:-

- i) HOLLOW CIRCULAR CROSS-SECTION
- ii) PLAIN CIRCULAR CROSS-SECTION

2001.7-1983

ANALYSIS OF FIBRES

CONDITION: 3 CLEAN DRY MASS WITH AGREED ALLOWANCES FOR MOISTURE

SAMPLE C

	1	2	MEAN	%
AMIDE - FIBRE COMPONENT (REGAIN AT 6.25%)	43.7	43.6	43.6	%
LIC - FIBRE COMPONENT (REGAIN AT 2.00%)	15.0	14.9	14.9	%
ON - WEFT GROUND YARN (REGAIN AT 8.50%)	25.3	25.6	25.5	%
* - WARP GROUND YARN (REGAIN AT 12.00%)	8.1	8.0	8.1	%
ESTER- WARP GROUND YARN (REGAIN AT 1.50%)	7.9	7.9	7.9	%

NET FIBRE RESULT - CALCULATION BASED ON EAST FIBRE MOISTURE REGAIN. OTHER SYNTHETIC FIBRES WERE PRESENT BLENDED IN THE EAST GROUND YARN.

3

(CONTINUED NEXT PAGE)

PAGE

3

© Australian Wool Testing Authority Ltd  
 Copyright - All Rights Reserved



This Laboratory is registered by the National Association of Testing Authorities, Australia, for:  
 - Chemical Testing of Textiles & Related Products : Registration No. 983  
 - Mechanical Testing of Textiles & Related Products : Registration No. 985  
 - Heat & Temperature Measurement : Registration No. 1356

\* The above tests have been performed in accordance with NATA's terms of registration. Samples and their identifying descriptions are normally submitted by the client unless otherwise stated. AWTA Textile Testing makes no warranty, implied or otherwise, as to the source of the tested sample. The above tests relate only to the sample tested. This document shall not be reproduced except in full and shall be rendered void if amended or altered. This document, the name AWTA Textile Testing or AWTA Ltd may not be used in any form of advertising without the prior written consent of the Managing Director of AWTA Ltd.



*[Handwritten Signature]*  
 AUTHORIZED SIGNATURE

D.J. WARD B.Sc., M.A.I.A.S.  
 MANAGING DIRECTOR

# AWTA TEXTILE TESTING

26 Robertson Street, Kensington, Victoria 3031  
P.O. Box 240 North Melbourne, Victoria 3061  
Phone (03) 9371 2126 Telex AA35301 Fax (03) 9376 3469  
Australian Wool Testing Authority Ltd - A.C.N. 006 014 106  
trading as AWTA Textile Testing

## TESTREPORT

CLIENT : VICTORIA UNIVERSITY  
OF TECHNOLOGY  
BALLARAT ROAD  
FOOTSCRAY VIC

TEST NUMBER : 7-463018-M  
DATE : 19.07.96

AS 2001.7-1983  
SECTION: 3

### ANAYLSIS OF FIBRES

	SPEC:	1	2	MEAN	
POLYOLEFIN		55.4	55.8	55.1	%
RUBBER		43.6	44.2	43.9	%

CLEAN OVEN DRIED BASIS - NO AGREED ALLOWANCE FOR RUBBER

PRETREATMENT WITH 0.1% DETERGENT CONDUCTED

SAMPLE D

AS 2001.7-1983  
SECTION: 10

### ANAYLSIS OF FIBRES

COTTON 100 %

SAMPLE E

59373

PAGE 2

© Australian Wool Testing Authority Ltd  
Copyright - All Rights Reserved



This Laboratory is registered by the National Association of Testing Authorities, Australia, for:  
- Chemical Testing of Textiles & Related Products : Registration No. 983  
- Mechanical Testing of Textiles & Related Products : Registration No. 985  
- Heat & Temperature Measurement : Registration No. 1356

\* The above tests have been performed in accordance with NATA's terms of registration. Samples and their identifying descriptions are normally submitted by the client unless otherwise stated. AWTA Textile Testing makes no warranty, implied or otherwise, as to the source of the tested sample. The above tests relate only to the sample tested. This document shall not be reproduced except in full and shall be rendered void if amended or altered. This document, the name AWTA Textile Testing or AWTA Ltd may not be used in any form of advertising without the prior written consent of the Managing Director of AWTA Ltd.



*[Signature]*  
AUTHORISED SIGNATORY

D.J. WARD B.Sc., M.A.I.A.S.  
MANAGING DIRECTOR

## **APPENDIX 4**

### **WINDOW LOWERING CRITERIA**

## Window Lowering Criteria

From previous experiments glass dislodgment was found to be a critical factor in the fire growth process. However glass dislodgment in a window is a complex process. Following initial cracking there was a delay prior to glass dislodgment and complete dislodgment occurred after a further period of time. Accordingly, the full process of glass dislodgment was a somewhat uncertain or random phenomenon. The uncertainty was such that it led to unexpected results in some previous fire tests. For example, a fire test which could have been expected to have gone to flashover remained a flaming fire. This was due to the glass cracking substantially, but there was no dislodging; although the glass was only hanging by one corner, it remained in place. This dislodgment should have proceeded to the complete failure of the window but did not due to the random nature of glass (window) dislodgment in a fire.

It was suggested in the literature that the temperature difference ( $\Delta T$ ) at which glass cracks can be predicted [1,2,3] based on breaking stress, linear thermal expansion coefficient and the modulus of elasticity of the glass. Yet it has also been suggested that this criteria is questionable [4]. Therefore, no clear definition of a glass dislodgment criteria was found in the literature.

It was decided that a window lowering criteria would eliminate the problems of partially and random dislodgment. Initial cracking occurs fairly predictably at a glass temperature of just under 200°C, and when there is dislodgment it will occur a number of minutes later (based on limited data obtained from previous fire tests conducted by CESARE). Based on this data 250°C was chosen as an initial criteria for lowering the window. Although opening the window gradually would have more closely represented the gradual dislodgment of glass over a set period of time, the problems associated with the initial pressure difference and the increase of velocity across the length of the window made it unpractical, (these changes would effect instrumentation across the bum room door). Therefore the window was lowered when the thermocouple mounted to the inner surface of the glass indicated a temperature of 250°C. One of the problems that were found was the direct fire attack on the thermocouple affected the readings. To protect the thermocouple from this it was insulated with a 3 mm thick copper disk.

The second criteria was to lower the entire window when the mass loss rate was less than 0.1 kg/min, as was the case when the bum room door was closed. These criteria were developed to assist flashover and in the case where the fire extinguished itself, to obtain additional flashover data.

These criterion have worked well - during all of the fire tests there was severe cracking before or at 250°C glass surface temperature and in tests (FO4 & FO5) major dislodgment occurred; in this case the fire was allowed to proceed without intervention. For tests F02 & F03 the second criteria was used and additional flashover data was obtained.

## References:

1. A.A.Joshi & P.J.Pagni, " Fire-Induced Thermal Fields in Window Glass; 1-Theory, 2-Experiments", *Fire Safety Journal* 22, pp 25-43 & 45-65, 1994.
2. P. J. Pagni & A.A.Joshi, " Glass Breaking in Fires", *Fire Safety Science - Proceedings of the Third International Symposium*, pp 791-802, 1991.
3. M.J. Skelly & R.J.Roby, "An Investigation of Glass Breakage in Compartment Fires", *Journal of Fire Protection Engineering* 3(1), pp 25-34, 1991.
4. G. W. Silcock & T.J. Shields, "An Experimental Evaluation of Glazing in Compartment Fires", *Interflam'93*, pp 747-756,1993.

## **APPENDIX 5**

### **EFFECTIVE HEAT OF COMBUSTION CALCULATIONS**



## 1. Heat Release Rate Equations

The equation for heat release rate is given as:

$$\Delta h_{c,eff}(t) = q_i(t) / -(dm/dt) \quad (\text{Equation 13- ASTM E 1354-90})$$

where

$\Delta h_{c,eff}$  = effective heat of combustion, kJ/kg  
 $q_i$  = heat release rate, KW  
 $m$  = specimen mass, kg

We can obtain  $(dm/dt)$  by taking the derivative of the total mass loss measured in the room at each time.

The effective heat of combustion,  $\Delta h_{c,eff}$ , is calculated using:

$$\Delta h_{c,eff} = (m_1 * HOC_1 + m_2 * HOC_2 + m_i * HOC_i) / \Sigma m_{(1 \text{ to } i)}$$

where

$m_{(1 \text{ to } i)}$  = specimen mass  
 $HOC_{(1 \text{ to } i)}$  = specimen heat of combustion

## 2. Effective Heat of Combustion for the three seater couch and single chair

The mass of each component making up the mass of the couch and the chair is shown in Table 3 in this report.

### 2.1 Three seater couch

$$Ah_{c,eff} = [(15+7+1.7)*18.4 + 7.5*27.2 + 5.87*32.5 + (4.0*0.75*30.8) + (4.0*0.25*25.2) + 0.3*32.5] / 41.82$$

$$\Delta h_{c,eff} = [439.8 + 20.4 + 190.8 + 92.4 + 25.2 + 9.75] / 41.82$$

$$Ah_{c,eff} = 778.29 / 41.82$$

$$Ah_{c,eff} = 18.61 \text{ MJ/kg}$$

## 2.2 Single Chair

$$\Delta h_{c,eff} = [(10+3.4+1.7)*18.4 + 2.1*27.2 + 2.35*32.5 + (1.5*0.75*30.8) + (1.5*0.25*25.2) + 0.1*32.5]/21.4$$

$$\Delta h_{c,eff} = [277.84 + 57.12 + 76.38 + 34.65 + 9.45 + 3.25]/21.4$$

$$Ah_{c,eff} = 258.69/21.4$$

$$Ah_{c,eff} = 21.43 \text{ MJ/kg}$$

## 3. Effective Heat of Combustion for the Burn Room

The mass of each item making up the fuel load in the burn room is shown in Table 2 of this report.

$$Ah_{c,eff} = [47.76*18.61 + 20.08*18.4 + 34.42*53.7 + 22.82*21.43 + 22.42*21.43 + 33.12*18.4 + 33.1*18.4 + 21.02*18.4 + 40.44*53.7 + 141.9*18.4]/544.28$$

$$Ah_{c,eff} = [888.81 + 369.47 + 1848.35 + 489.03 + 480.46 + 609.41 + 609.04 + 386.77 + 2171.63 + 2610.96]/544.28$$

$$Ah_{c,eff} = 10463.93/544.28$$

$$Ah_{c,eff} = 19.23$$